

CREEDE DISTRICT
RECEIVED
JUL 20 1982

District Clerk _____
District Ranger _____
Reg. W.L. Rec. Staff _____
Ext. Tech. _____
Tel. Staff - 11 _____
Forestry 9 _____
Tel. Staff 7 _____
Rec. Staff _____
Ext. Cont. _____

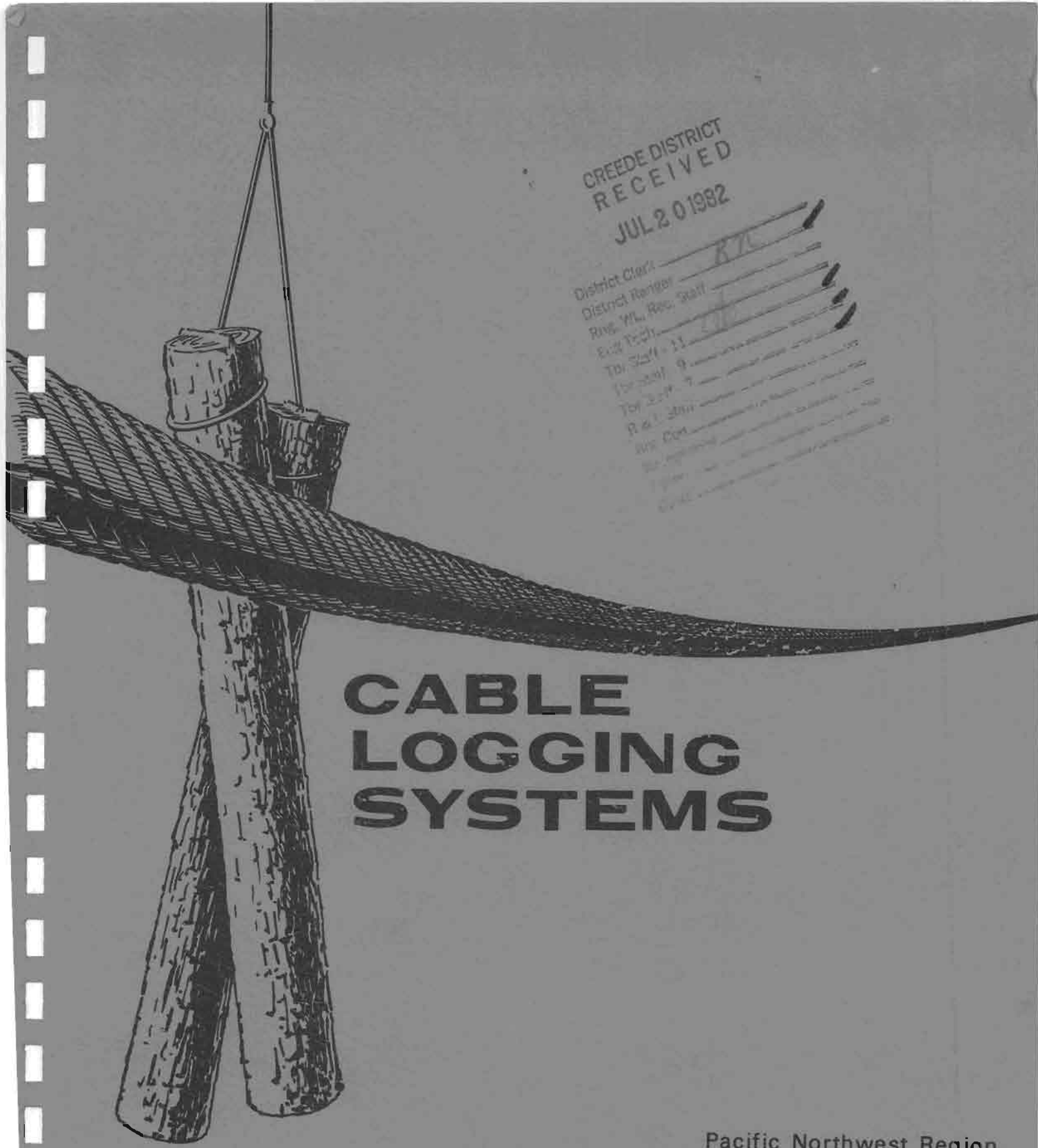

CABLE LOGGING SYSTEMS

Pacific Northwest Region
U.S. Department of Agriculture-Forest Service

CABLE LOGGING SYSTEMS

by

Donald D. Studier
Civil Engineer

Virgil W. Binkley
Logging Engineer

Division of Timber Management
Forest Service, U.S. Department of Agriculture
Portland, Oregon

Permission to reprint for sale granted to Oregon State
University by the Forest Service Region 6, USDA, 1974.

1974

Reprinted by
O.S.U. Book Stores, Inc.
Corvallis, Oregon

1976

Litho-U.S.A.



CONTENTS

INTRODUCTION

Background

Planning

Cable Systems

Options Logging Method

Yarding System Capability

PREFACE

This book is a state-of-the-art document on cable logging systems. It describes rigging configurations that have been used in the forests of the United States, discusses landing, anchors, guyline and rigging requirements for various cable systems, and provides a listing of cable logging equipment.

There is a need in the Forest Service for a publication that gathers together information on cable logging systems. This book tries to fulfill this need. Even though there has been a rapid growth in technology, the rigging configurations shown in this book are basic. They have been used in the past, and they will continue to be used in the future.

Bringing all of this information together has been a task that has taken over three years. Many people have provided time and information. These include: Joseph W. Gorsh, Region 1, U. S. Forest Service; James Seabaugh, Siuslaw National Forest, Region 6, Keith McGonagill, Willamette National Forest, Region 6; and John Warner, Six Rivers National Forest, Region 5. The illustrations were done by Thomas G. Reul, Dan L. Maier, and DeLynn Colvert all of Region 2, U. S. Forest Service. Charles O. Campbell, Biles-Coleman Lumber Company, contributed a great deal to this book including the section on Mechanics of Anchoring. Rodney Prellwitz, Region 1, U. S. Forest Service, wrote the section on Deadmen Anchors.

The use of trade, firm, or corporation names in this book is for the information and convenience of the reader. Such use does not constitute an official endorsement or approval by the U. S. Department of Agriculture of any product or serve to the exclusion of others which may be suitable.

DONALD D. STUDIER
Civil Engineer

VIRGIL W. BINKLEY
Logging Engineer

CONTENTS

Chapter		
1	INTRODUCTION.....	1
	Background.....	1
	Planning.....	1
	Cable Systems.....	1
	Optimum Logging Method Sketch.....	3
	Yarding System Capability Table.....	4
2	TERMINOLOGY.....	5
	Single-Span Profile.....	7
	Single-Span Skyline Conditions.....	8
	Skyline Road Plans.....	9
	Felling Patterns to Facilitate Yarding.....	10
3	LANDINGS.....	12
	Size of Landings.....	12
	Types of Leads.....	15
	Landing Requirement Chart.....	16
	Landing Construction.....	17
4	RIGGING AND WIRE ROPE.....	20
	Rigging Procedures.....	20
	Rigging Equipment.....	21
	Wire Rope Description.....	22
	Wire Rope Strength Efficiency Table.....	23
	Wire Rope Weights, Strengths and K Values.....	25
	Drum Capacity Table.....	26
5	MECHANICS OF ANCHORING.....	27
	Rigging Practices.....	28
	Stump Anchors.....	29
	Tieback Load/Tieback Angle Relationships.....	30
	Stump Height/Load and Stump Diameter Relationships.....	39
	Skyline Load/Anchor Stump Load Table.....	40
	Deadman Anchors.....	42
	Pull Correction Chart.....	47
	Soil-Type/Deadman Log Dimensions Charts.....	48-49
	Deadman Depth Charts.....	50
6	MECHANICS OF GUYLINES.....	51
	Guy Number and Position Factor Table.....	52
	Applied Force Table.....	53
7	LOGGING SYSTEM PLANNING.....	56
	Paper Planning.....	56
	Timber Harvest Planning Outline.....	58
	Reconnaissance.....	59
	Design.....	59
	Logging System Choice.....	60
	Other Considerations.....	61

8	SALE LAYOUT CONSIDERATIONS BY SILVICULTURAL CUTTING PRESCRIPTION....	64
	Clearcutting.....	64
	Highlead.....	64
	Relative Yarding Distance by Spar Height.....	66
	Criteria for Choosing Highlead Method.....	68
	Live Skylines.....	70
	Running Skylines.....	75
	Standing Skylines (European Systems).....	75
	Standing Skylines with Remote-Control Carriages.....	86
	Balloon.....	87
	Overstory Removal.....	91
	Standing Skylines--European Systems.....	94
	Standing Skylines with Remote Control Carriages.....	94
	Live Skylines With Remote-Control Carriages.....	95
	Running Skylines With Mechanical Slackpulling Carriage.....	95
	Thinnings.....	99
	Live Skyline-Mobile Yarders.....	99
	Standing Skylines.....	102
9	DESCRIPTION OF CABLE LOGGING SYSTEMS.....	103
	Shovel Loader Jammer.....	104
	Jammer With Wood Boom.....	106
	Mobile Shovel Yarder.....	108
	Highlead.....	110
	Live Skyline With Mechanical Carriage.....	112
	Live Skyline, Shotgun or Flyer.....	114
	Slackline.....	116
	Live Skyline With Radio-Controlled Carriage.....	118
	Live Skyline With Radio-Controlled Grapple.....	120
	Live Skyline With Dutchman.....	122
	Side Mount Tower With Mechanical Slackpulling Carriage.....	124
	North Bend.....	126
	South Bend.....	128
	Tyler.....	130
	Skidder.....	132
	Skyflier.....	134
	European Skyline.....	136
	Multispan Skyline.....	138
	Standing Skyline With Remote-Control Carriage.....	140
	Standing Skyline With Radio-Controlled Carriage.....	142
	Standing Skyline, Radio-Controlled Carriage Sled-Mounted Yarder.....	144
	Standing Skyline, Remote-Controlled Carriage, Mobile Tower.....	146
	Running Skyline With Mechanical Slackpulling Carriage.....	148
	Running Skyline With Mechanical Grapple.....	150
	Running Skyline With Remote-Control Grapple.....	152
	Running Skyline With Chokers, Grabinski.....	154
	Balloon Haulback Configuration.....	156
	Balloon Inverted Skyline Configuration.....	158
	Summary of Cable Systems.....	160
	Yarder Descriptions.....	162
	Highlead (Small 1-1/8" mainline or less).....	162
	Highlead (Large, mainline larger than 1-1/8").....	165
	Slackline.....	171
	Running Skyline.....	174

European Yarders.....	177
Other Yarders.....	179
Towers and Undercarriages.....	181
Skyline Carriages.....	182
Grapple Carriages.....	185
Non-Slackpulling Carriages.....	186
Slackpulling Carriages.....	187
Carriage Descriptions.....	190
APPENDIX I.....	200
List of Publications	
Forest Service Research Papers.....	201
Forest Service Research Notes.....	202
General References.....	202
Rigging References.....	204
APPENDIX II.....	205
Forms	

CHAPTER 1 INTRODUCTION

BACKGROUND

Steam and cables joined forces in the logging industry around the turn of the century with most of the original cable-logging work accomplished in the Pacific Northwest. "Steam pot" yarders pulled the logs into the landing at drum-level--with attendant hangup problems, particularly with the high stumps of the day. Often, skidways were required, just as in the ox and horse-logging which preceded the cables.

The solution was to get some "lead" on the logs, to provide some pull from above to get them away from the obstacles.

The first spar, to provide this lead, was reportedly rigged by a sailing ship's rigger in the late 1800's; hence the term, "rigging". Lidgerwood patented the railroad skidder, a yarder and spar combination, in 1902. Used in railroad logging, the Lidgerwood was the forerunner of today's mobile spar.

Steampower was gradually replaced by gasoline-powered internal combustion engines. These were, in turn, replaced by diesel engines. Today's logger operates highly-sophisticated machines with air controls, water-cooled brakes and interlocking drums.

Present intensive forest management requirements, combined with operations on more difficult terrain holding more sensitive soils, has created demands for the highest of technological developments. This handbook presents these developments in cable-logging systems for timber harvesting. Procedures for planning their use and for operating the systems are also outlined.

PLANNING

Logging engineering or logging planning is the interface between multiple use, environmental concerns, and timber harvesting. Logging engineering covers all timber harvesting activities from "the stump to the dump". The Logging Engineer's job is to insure that an area can be harvested and meet the resource objectives, using the indicated equipment and practices.

Obviously, the Logging Engineer must be able and willing to work with other specialists to insure that the minimum cost solution is identified for each timber harvest area. Cost includes not only the dollar value of the activity, but also the external costs associated with timber harvest. These may have no dollar equivalent.

Logging is a specialized form of materials handling and transportation. The fact that the material in question is logs located on forested land only further defines the handling system requirements. Environmental factors more specifically define the conditions under which logs must be transported. In short, the forest must be harvested within the constraints of sound land management.

CABLE SYSTEMS

Cable-logging systems in this handbook are divided into five categories:

ground lead, live skyline, standing skyline, running skyline, and balloon. Each system has its own rigging and operational characteristics. Each is adaptable to certain topographic characteristics and silvicultural prescriptions. The job of the Logging Engineer is to match the system and the terrain to meet objectives prescribed by the land manager.

Figure 1-1 illustrates yarding system capabilities for a range of conditions. The chart also includes helicopters, tractors and skidders. Table 1-1 is a tabulation of the systems, along with their approximate external yarding distances. From the chart or table, a comparison of access road spacing relative to yarding distances of the various systems can be made.

As log transportation requirements become more complex, the Logging Engineer is faced with more complex sale transportation problems. He must become more familiar with systems and how they are employed to achieve maximum land management benefits at minimum cost. The purpose of this book is to aid in that goal.

Optimum yarding distances and slope percent of each logging system

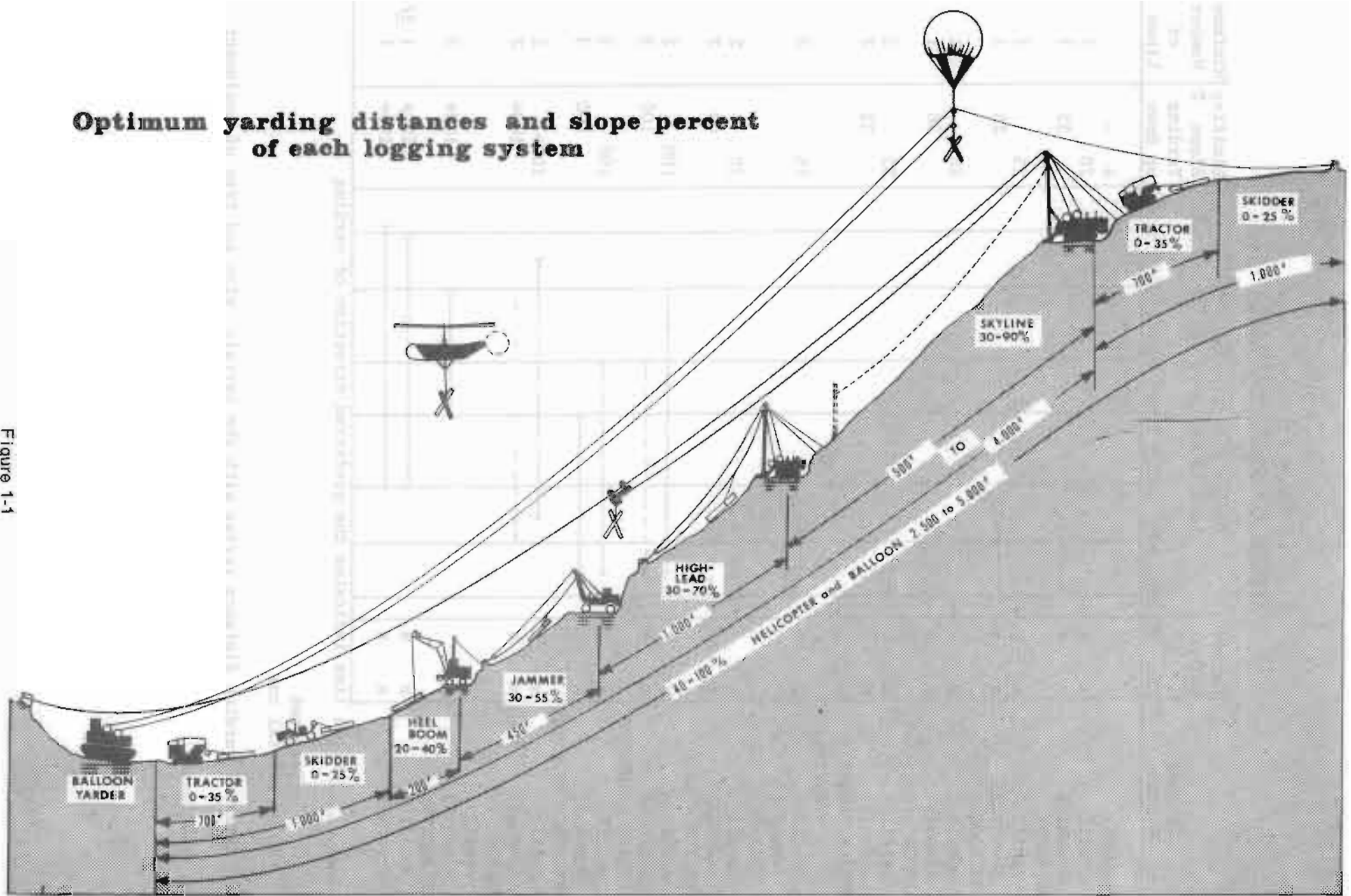

Figure 1-1

Table I-1
Yarding Systems Capabilities

Yarding System	Harvest Method		Design for External Yarding Distance of: <u>2/</u>							Limiting Slope % Yarding up down	Minimum Number of Lines
	CC	<u>1/</u> PC	200'	600'	1000'	1500'	2000'	3000'	5000'		
TRACTOR										+ -	
uphill	x	x	←							20	1
downhill	x	x		→						35	1
SKIDDERS											
uphill	x	x	←							15	1
downhill	x	x		→						25	1
HEELBOOM											
uphill	x	x	←							40	1
downhill	x	x		→						30	1
JAMMER w/Haulback											
uphill	x		←							55	2
downhill	x			→						35	2
MOBILE YARDER w/Carriage											
uphill	x	x	←							75	2
downhill				→							
HIGHLEAD											
uphill	x		←							70	2
downhill	x			→						40	2
SKYLINE - LIVE											
uphill	x	x	←							100	2
downhill	x	x		→						100	3
SKYLINE - RUNNING											
uphill	x	x	←							100	3
downhill	x	x		→						100	3
SKYLINE - STANDING											
uphill	x	x	←							100+	2
downhill	x	x		→						100+	2
BALOON											
uphill											
downhill	x									100+	2
HELICOPTER											
uphill	x	x								100+	1 <u>3/</u>
downhill	x	x								100+	1

solid line indicates the preferred direction of yarding

1/ CC = clear cut
PC = partial cut

2/ External yarding distance varies with the terrain, size and type of equipment

3/ Loadline

CHAPTER 2 TERMINOLOGY

Why logging system terminology? Standardization of logging terms is needed to facilitate communications among planners, designers, and loggers.

Logging is the total consideration of moving logs from stumps to processing plant. This includes planning log transportation and road construction, felling and/or bucking, yarding, loading, hauling and site preparation. For the purpose of this book, we will address ourselves mainly to yarding. Yarding is the act or process of conveying logs to a landing. It is the first handling of the logs.

All cable systems have common requirements for planning and implementation. First, landings are required and must meet minimum standards. Anchor points for guys and skylines must be available or made. Landings must be located so blind leads do not occur on highlead settings and so that deflection is adequate for sky-lines. A blind lead occurs when the line of sight from the bullblock to the tail-block is obstructed.

A skyline is a cableway stretched taut between two spars and used as a track for log carriers. The log carrier is more commonly referred to as a carriage, a wheeled device which rides on the skyline.

A profile of a single-span skyline is illustrated in figure 2-1. The midspan deflection is defined as the vertical distance between the chord and the skyline. One of the limiting factors in skyline yarding is the load-carrying capability of a skyline which is determined using procedures outlined in PNW-39.

External Yarding Distance (EYD) is the slope distance from the landing to the outer cutting unit boundary. Average Yarding Distance (AYD) is the external yarding distance divided by the appropriate factor:

- 0.5 for rectangular setting
- 0.667 for a fan-shaped setting with a common landing
- 0.333 for a fan-shaped setting with a common anchor point

Span is the horizontal distance between the headspar or anchorpoint and the tailspar or anchorpoint. Skyline Length is the amount of line suspended between the headspar and tailspar.

Deflection depends upon topography. Figure 2-2 illustrates four different slope situations. Convex slopes are not conducive to skyline systems without intermediate supports. For further information see PNW-25 and PNW-66.

A setting is defined as the area logged to one yarder position. Figure 2-3 illustrates a plan view of a rectangular setting and a fan-shaped setting. A sky-line road is the area bounded by the length and lateral yarding width of any given skyline setting. The skyline corridor is the clearing width needed to allow passage of the carriage and logs when yarding in partial cuts or thinnings.

Felling patterns, as shown in figure 2-4, play an important role in yarding. Contour felling facilitates yarding by providing a greater opportunity for the grapple to pass directly over the logs. The herringbone pattern is recommended when skyline-yarding in a partial cut or thinning, to reduce damage to the residual stand. The perpendicular pattern reduces hangups when ground-lead yarding.

In partial cuts, a means must be provided to bring the log laterally to the skyline before it is transported to the landing. A carriage that contains a skidding line or one that allows a skidding line to pass through it is used for this purpose. A cable yarding system capable of skidding logs laterally, as well as moving them up or down the skyline to the landing is referred to as a skyline crane. The skyline crane yarding cycle is composed of six elements as shown in figure 2-5. Carriage outhaul is accomplished by gravity or by pulling it out with the haulback line. Once the carriage is stopped, the skidding line is pulled laterally and the logs are hooked to the skidding line with the aid of chokers. The logs are then skidded laterally to the carriage and then yarded to the landing. At the landing the logs are unhooked.

Other terms are listed in the "Glossary of Cable Logging Terms" published by the Pacific Northwest Forest and Range Experiment Station and in "Woods Words" by Walter F. McCulloch (Oregon Historical Society, 1958).

SINGLE SPAN PROFILE

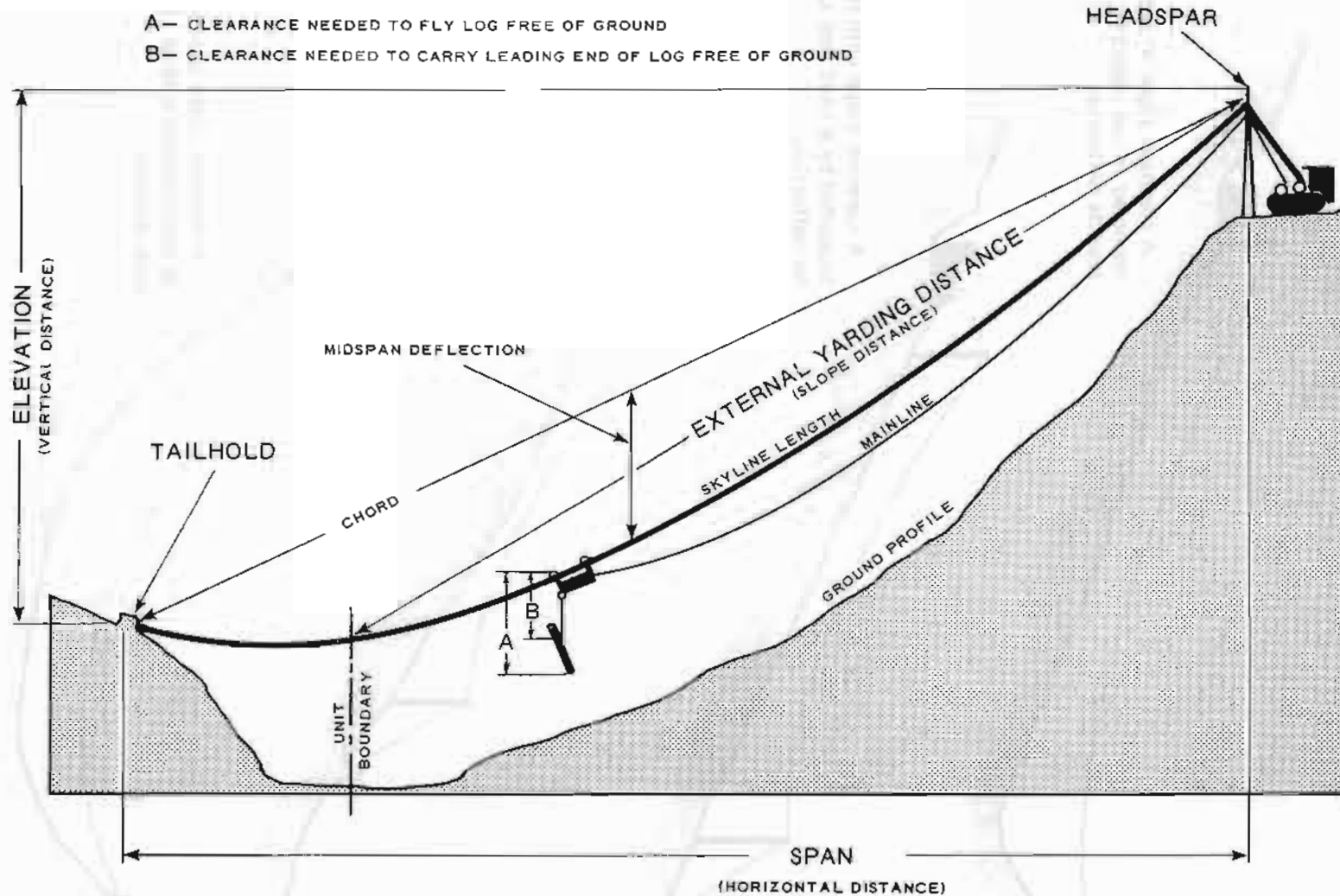

Figure 2-1

TYPICAL SINGLE - SPAN SKYLINE CONDITIONS

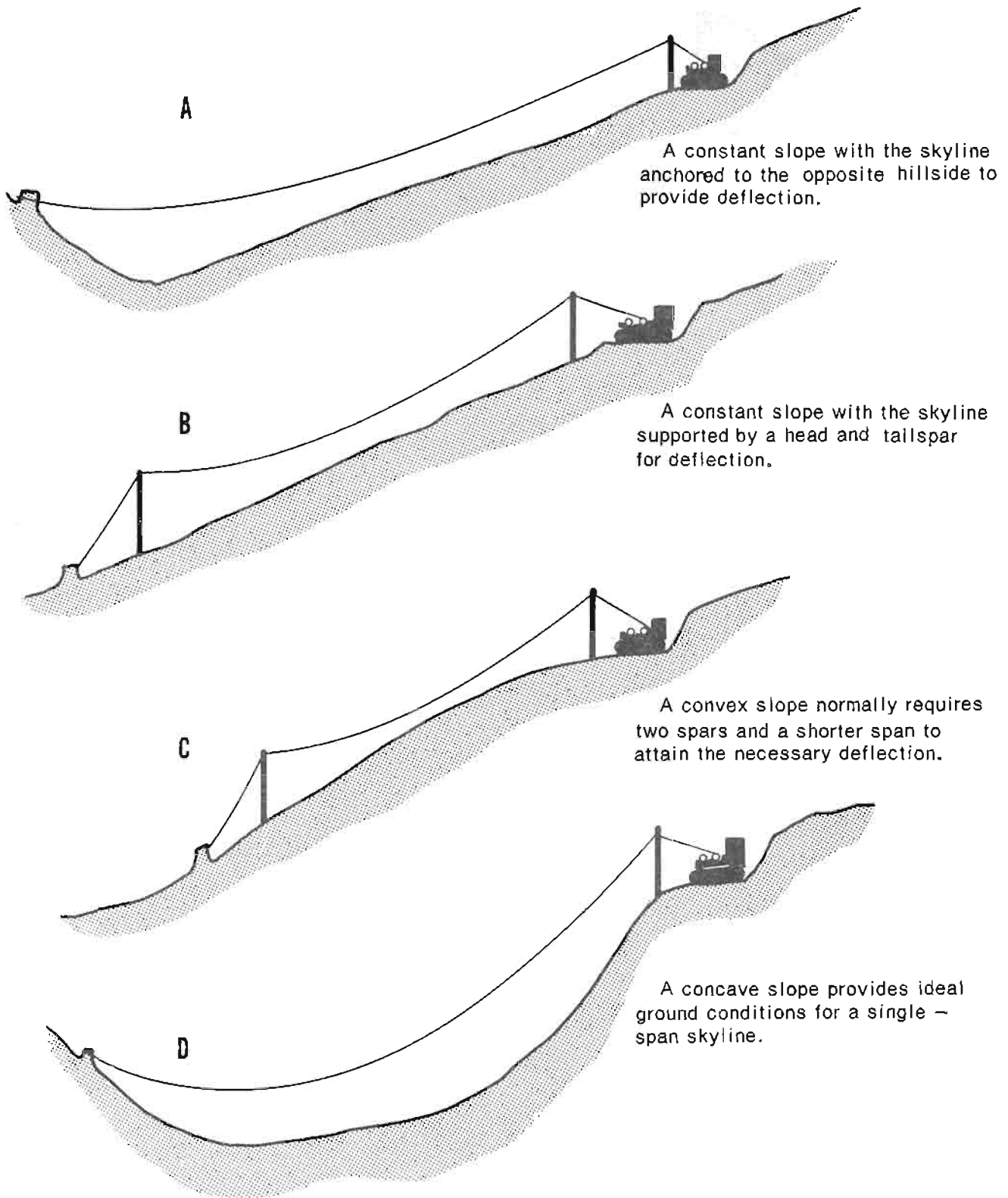
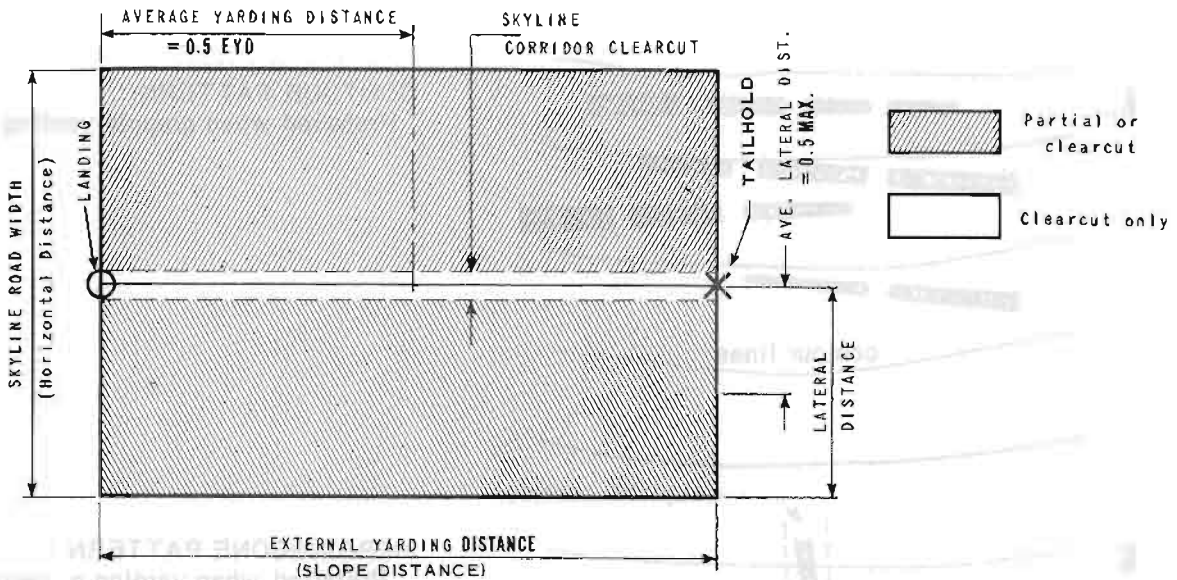
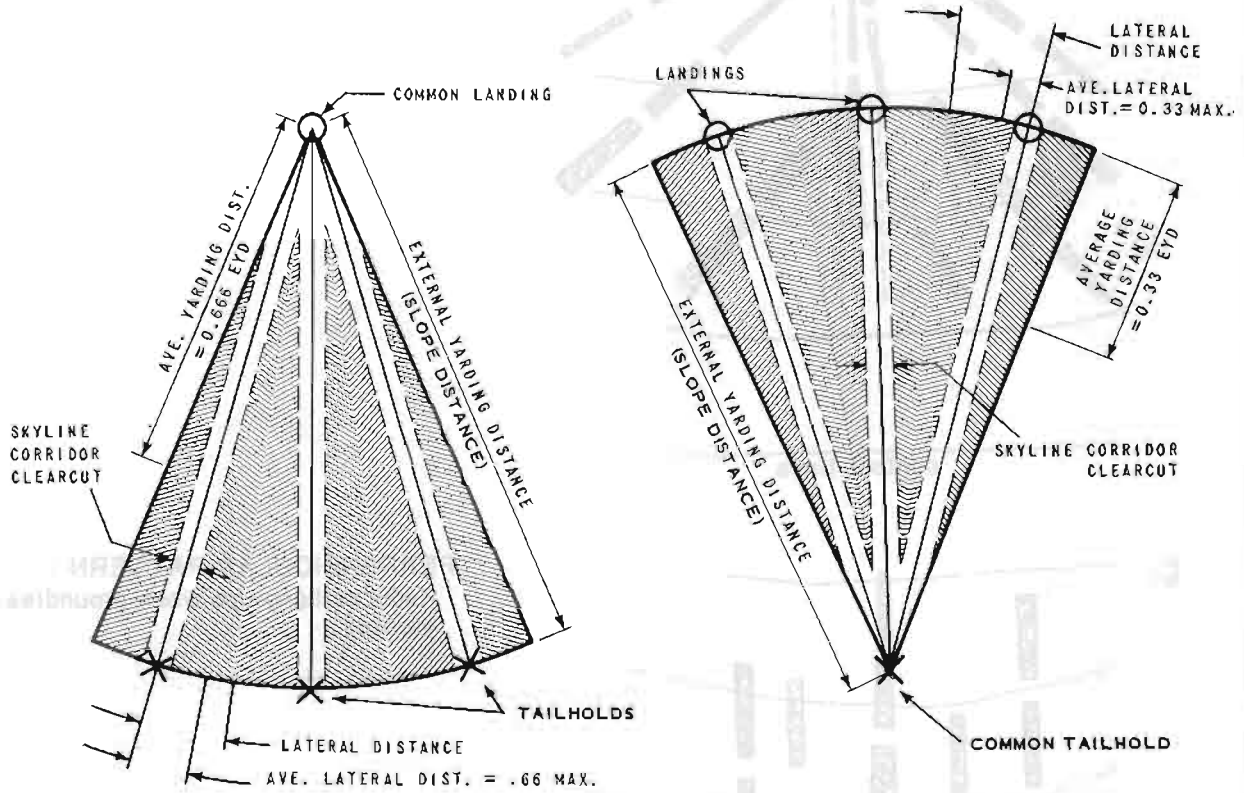

Figure 2-2

SKYLINE ROAD PLANS



PLAN VIEW OF RECTANGULAR SETTING



PLAN VIEW OF FAN SHAPED SETTINGS

Figure 2-3

FELLING PATTERNS TO FACILITATE YARDING

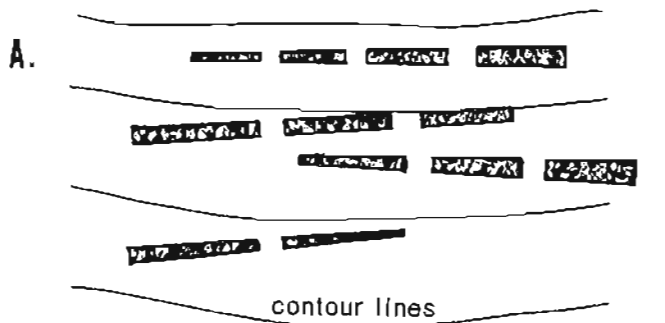

CONTOUR PATTERN :
Preferred when grapple yarding .

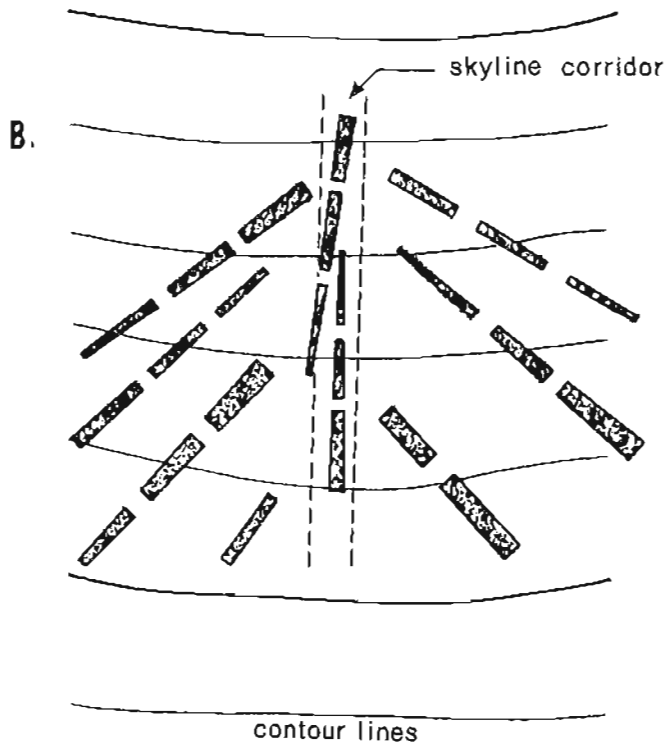

HERRINGBONE PATTERN :
Preferred when yarding a partial cut
with a skyline yarder.

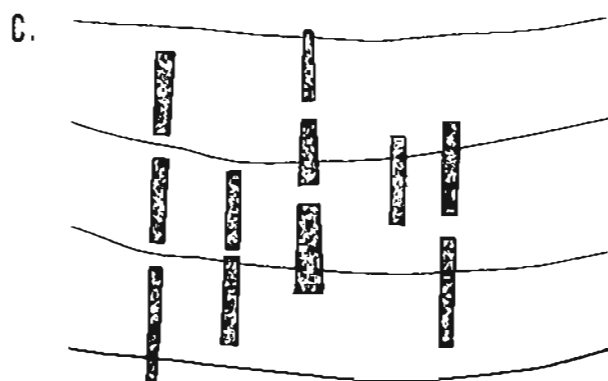

PERPENDICULAR PATTERN :
Reduces hang-ups when groundlead
yarding.

Figure 2-4

Landing is where logs are collected preparatory to further transportation. It must be located so as to provide access to all the logs in the area served by it and it must be large enough to provide operating room for the equipment. Landings must be located to allow logs to be transported away from them by waterways, trucks, trains, cable systems, or helicopters.

LANDING LOCATION

Landings must be located to complement the yarding system. Good landing sites may be available, but they may not meet the needs of the yarding method.

Landings must be located below the skidding line to avoid interference with the skidding operation. The landing should be located in a well-drained area to avoid water logging. The landing should be located in a well-drained area to avoid water logging.

Landings must be located to provide adequate safety. There must be adequate guy wires to support the landing. The landing should be located in a well-drained area to avoid water logging. The landing should be located in a well-drained area to avoid water logging.

Skidline landings must be located on points of ridge, or on the slope, and provide good skyline deflection. The landing should be located in a well-drained area to avoid water logging. The landing should be located in a well-drained area to avoid water logging.

Landings must be located to provide adequate skyline deflection. The landing should be located in a well-drained area to avoid water logging. The landing should be located in a well-drained area to avoid water logging.

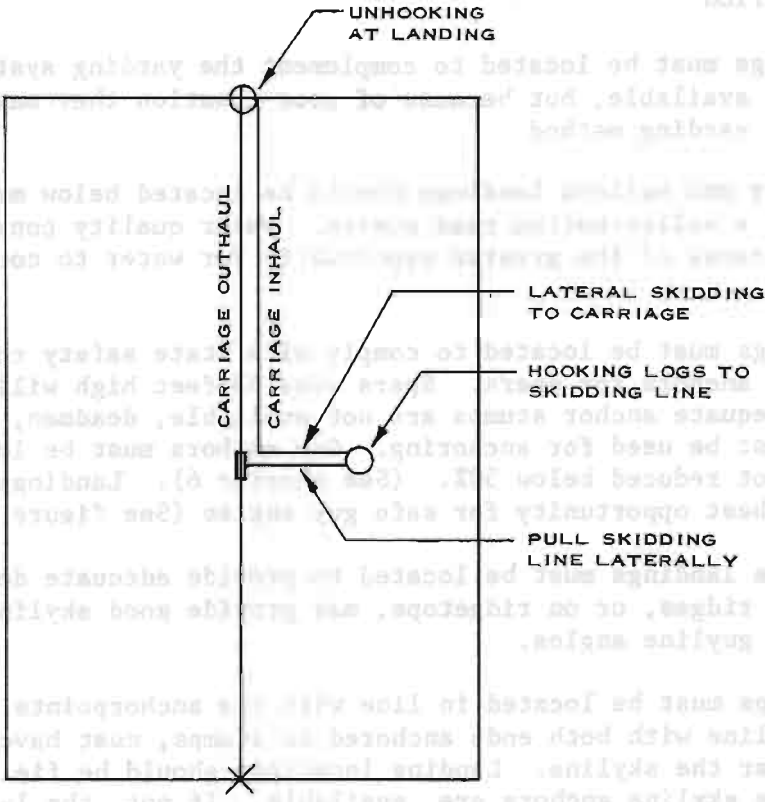

SKYLINE CRANE YARDING CYCLE

For downhill yarding, landing must be located in a well-drained area to avoid water logging. The landing should be located in a well-drained area to avoid water logging.

Landings must be located to provide adequate skyline deflection. The landing should be located in a well-drained area to avoid water logging. The landing should be located in a well-drained area to avoid water logging.

SIZE OF LANDING

Landing size depends upon many factors. The more economical the log handling system, the more economical the landing. The landing should be located in a well-drained area to avoid water logging. The landing should be located in a well-drained area to avoid water logging.

Figure 2-5

CHAPTER 3 LANDINGS

A landing is where logs are collected preparatory to further transportation. It must be located so as to provide access to all the logs in the area served by it and it must be large enough to provide operating room for the equipment. Landings must be located to allow logs to be transported away from them by waterways, trucks, trains, cable systems, or helicopters.

LANDING LOCATION

Landings must be located to complement the yarding system. Good landing sites may be available, but because of poor location they may not meet the requirements of the yarding method.

Tractor and balloon landings should be located below material to be moved, resulting in a valley-bottom road system. Water quality considerations become more important because of the greater opportunity for water to concentrate at the landing.

Landings must be located to comply with state safety codes. There must be adequate guy anchors for spars. Spars over 55 feet high will need six to eight guys. If adequate anchor stumps are not available, deadmen, rockbolts, or even tractors, must be used for anchoring. Guy anchors must be located so that effectiveness is not reduced below 50%. (See chapter 6). Landings located on sidehills provide the best opportunity for safe guy angles (See figure 3-1).

Skyline landings must be located to provide adequate deflection. Locations on points of ridges, or on ridgetops, may provide good skyline deflection; but they produce poor guyline angles.

Landings must be located in line with the anchorpoints. For example, a standing skyline with both ends anchored to stumps, must have the landing located directly under the skyline. Landing locations should be field-checked to determine that adequate skyline anchors are available. If not, the landing location must be changed.

For downhill yarding, landings must be located to provide ample area between the hill, or backslope, and the spar. The area is needed to catch loose logs and debris from downhill yarding (See figure 3-1).

Finally, landings must be located to facilitate yarding. On highlead settings, landings should be located to avoid blind leads. For any system, the landings should be located to minimize sidehill yarding. In some cases, damage to the residual stand, or to the soils, may be avoided by using additional landings to eliminate blind leads, sidehill yarding, or inadequate deflections.

SIZE OF LANDINGS

Landing size depends upon many factors; but in general, the larger the landing, the more economical the log handling. This, however, may be in direct conflict with some of the land management considerations which usually restrict landing size. In any event, landings must be located so logs may be handled safely and efficiently.

LANDING LOCATION

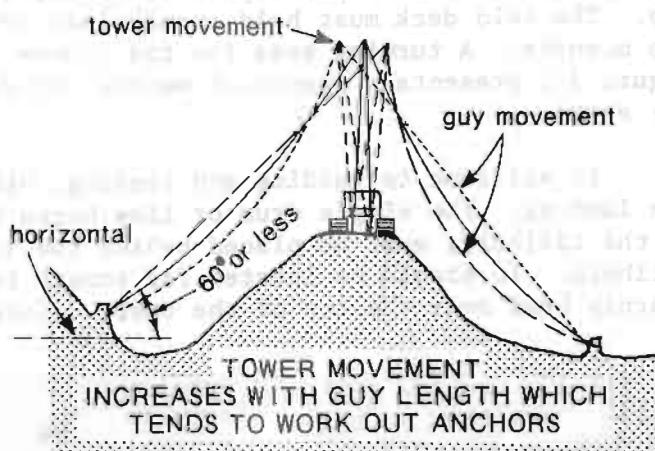
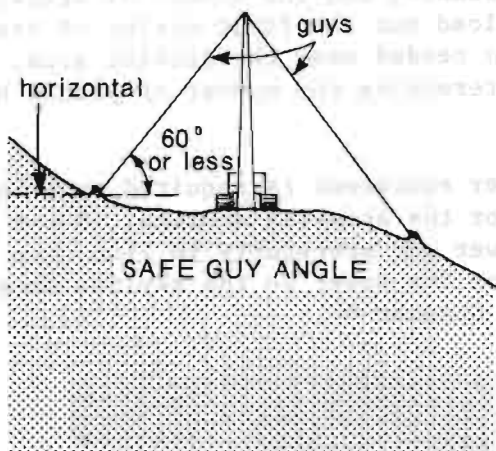
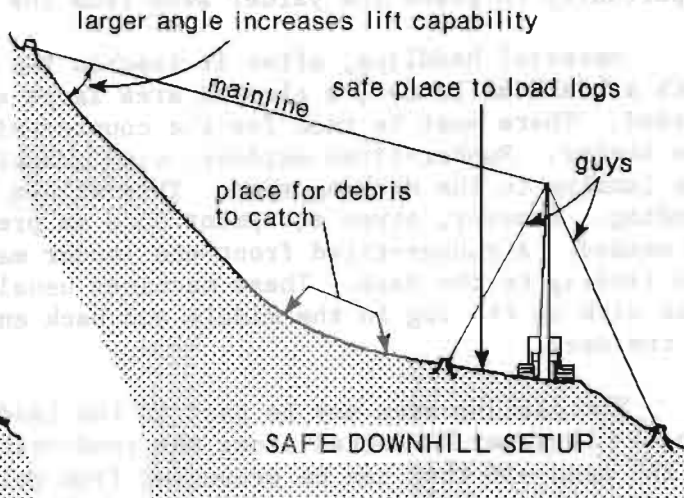
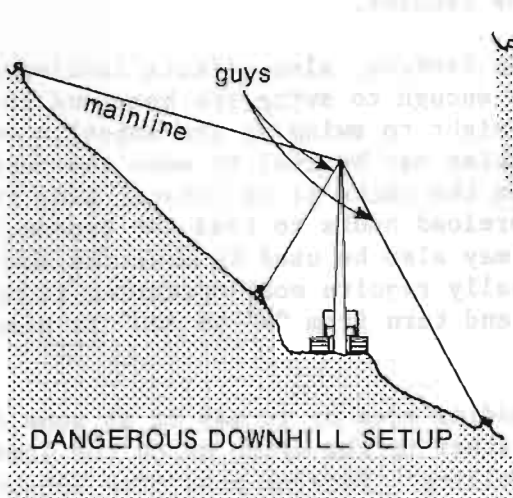
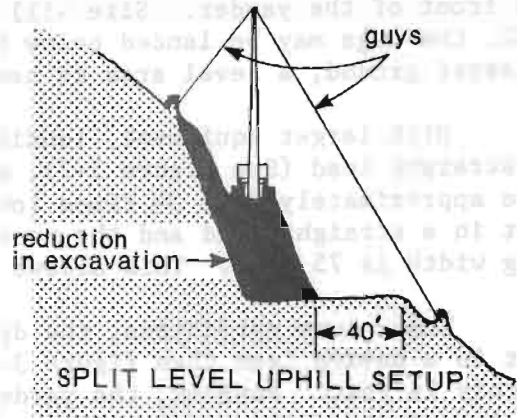
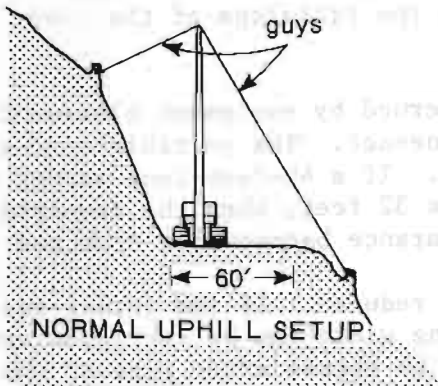
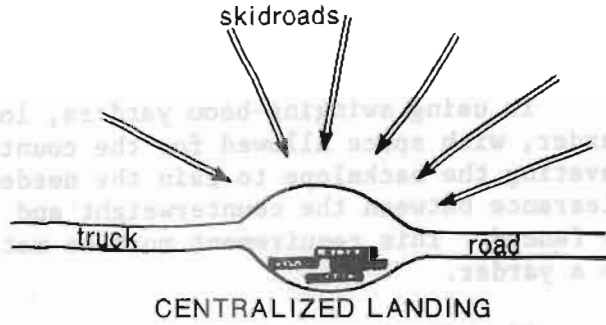
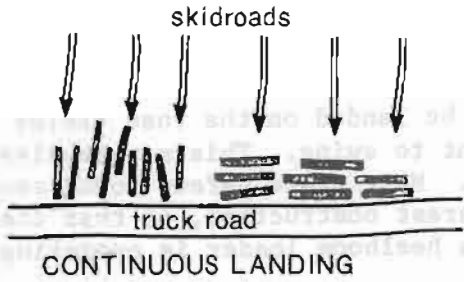

Figure 3-1

Equipment size and numbers have a direct effect on landing size. Small yarders, such as those used for thinnings, require a road width of 10 or 12 feet in order to operate.

In using swinging-boom yarders, logs may be landed on the road beside the yarder, with space allowed for the counterweight to swing. This may involve excavating the backslope to gain the needed room. Most state safety codes require clearance between the counterweight and the nearest obstruction, or that the area be fenced. This requirement must be met when a heelboom loader is operating next to a yarder.

If a fixed tower is used with the yarder, then a safe landing area is needed in front of the yarder. Size will depend upon material length. On slopes under 30%, the logs may be landed below the road or on the fillslope of the road. On steeper ground, a level area is needed.

With larger equipment, landing size is governed by equipment placement. With a straight lead (See figure 3-2), more width is needed. The portable spar-yarders are approximately 3 to 3½ times longer than wide. If a 40-foot-long yarder-spar is set in a straight lead and the mean log length is 32 feet, then the required landing width is 75 feet. This allows four feet clearance between the spar and the log.

Under some conditions, the distance can be reduced. If the yarder-spar is set in a square lead (See figure 3-2), the landing width can be decreased approximately 24 feet. However, the yarder may have to be turned after part of the unit is logged, to avoid yarding into a V-lead. A rigged spar tree might provide an opportunity to place the yarder away from the landing.

Material handling, after it reaches the landing, also affects landing size. With a heelboom loader, a cleared area large enough to swing the boom and log is needed. There must be room for the counterweight to swing at the opposite end of the loader. Rubber-tired skidders with grapples may be used to move the logs from the landing to the decking area. This allows the decks to be located away from the landing. However, other equipment such as preload bunks to load the trucks, will be needed. A rubber-tired front-end loader may also be used to move the logs from the landing to the deck. These machines usually require more operating room. They must pick up the log in the middle and back and turn from 90° to 180° to place logs on the deck.

The decking area may be part of the landing area or it may be at some distance. Logs may be decked along the road--either in the ditch or on the lower side of the road--if they can be prevented from rolling. Decking area size depends upon log size, logs yarded per day, sorts, haul distance, and the number of trucks hauling. The cold deck must hold enough logs to load out the first string of trucks in the morning. A turning area for the trucks is needed near the decking area. Figure 3-3 presents a graphical method for determining the number of pieces handled per setup.

In addition to yarding and loading, other equipment is required on or near the landing. The single drum or line horse for the standing skyline, if not placed at the tailhold, must be placed behind the tower and preferably in line with the tailhold. It should be located far enough from the tower so the skyline does not sharply bend over the top of the tower. (See Chapter 6).

THREE TYPES OF LEADS IN HIGHLEAD LOGGING

(Plan View)

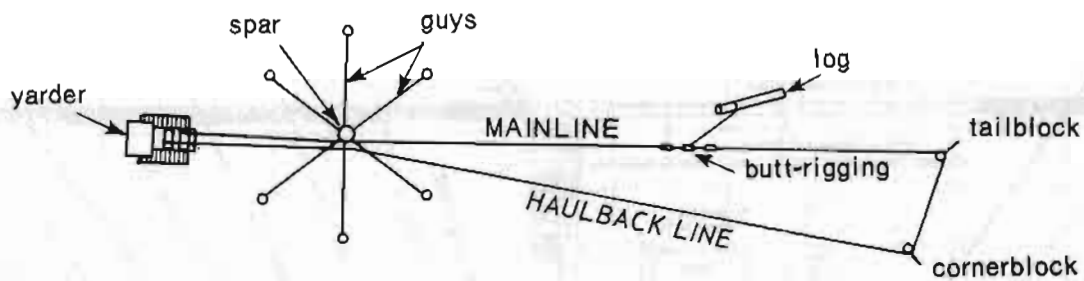

STRAIGHT-LEAD. — Occurs when yarding is in line with the yarder and spar. This condition subjects the guys to the least strain.

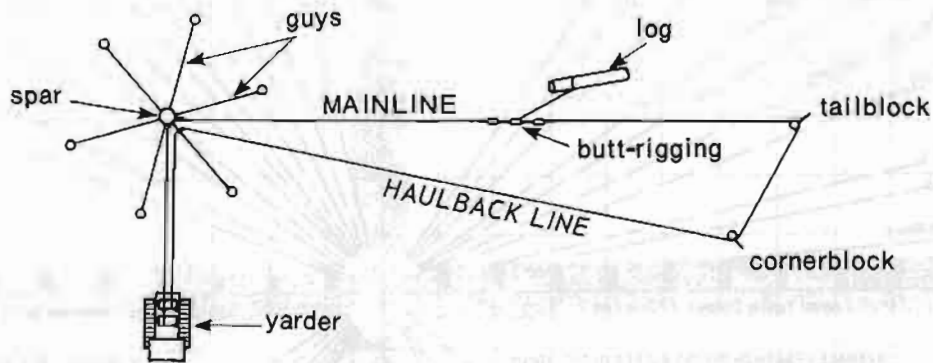

SQUARE-LEAD. — Occurs when yarding at right angles to the yarder and spar. The resultant force on the spar must be sustained by the opposing guys.

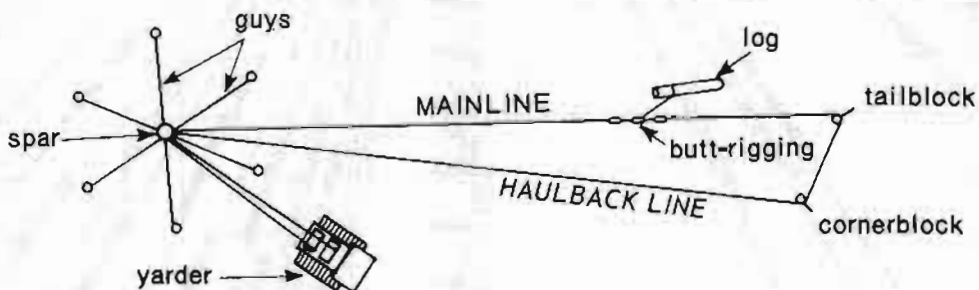

V - LEAD. — Occurs when the resultant angle in the mainline at the spar is less than 90 degrees. This block purchase on the opposing guys creates an unsafe working condition on rigged spar trees.

Figure 3-2

LANDING REQUIREMENTS BY: Yarding Condition, Area, Volume, Piece Size & Production

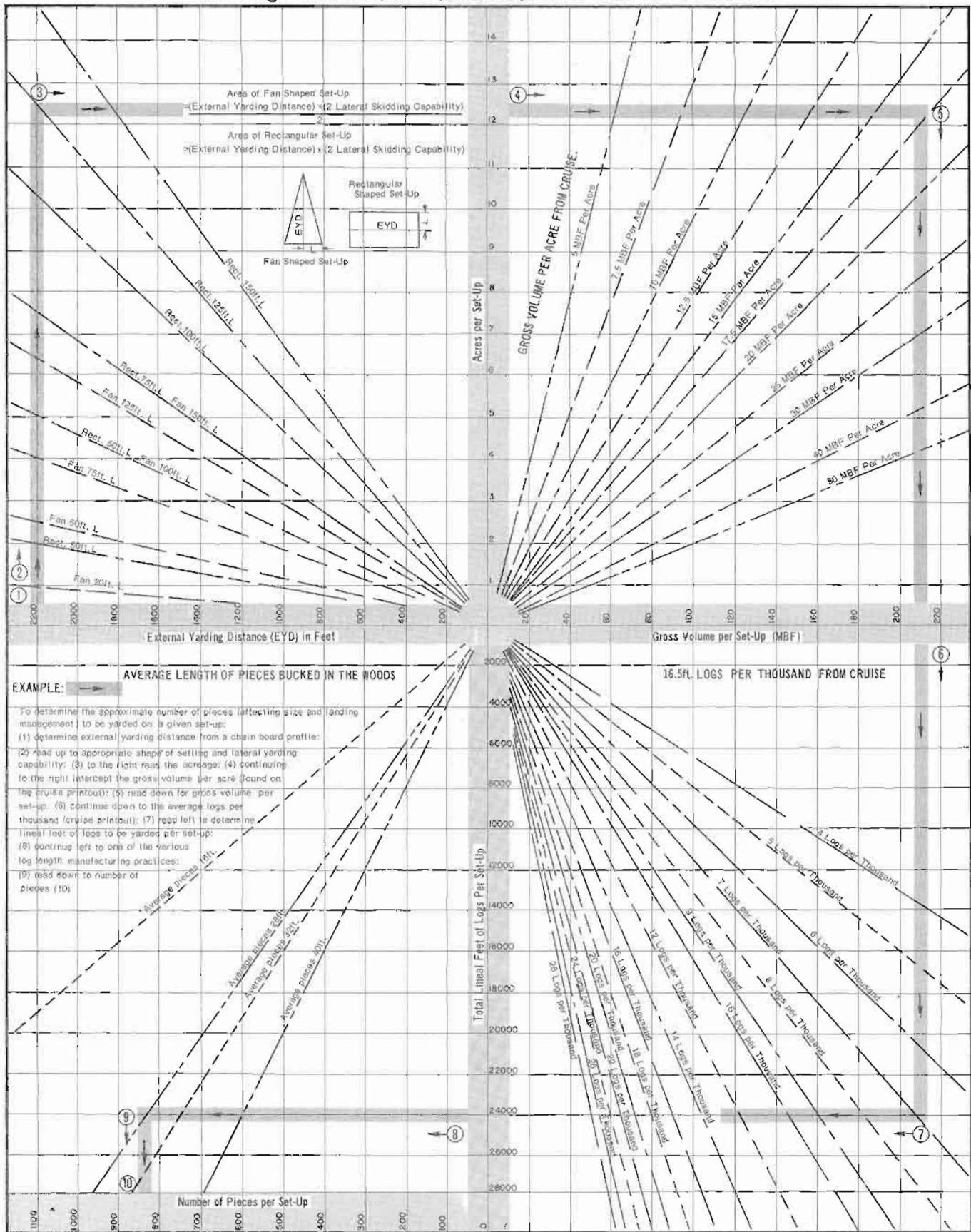

Figure 3-3

Parking areas must be provided for crew busses, pickup trucks, fuel equipment and other equipment such as tractors or rigging trucks.

With yarding systems cost-sensitive to maximum payloads, such as skyline and balloon systems, tree-length logs may be yarded. Then, the landing must be large enough so that the logs may be laid on the ground for bucking into standard lengths.

LANDING CONSTRUCTION

Landings should be built reasonably level and well drained. Water should not be allowed to accumulate. Many soil failures occur on landing areas because of improper design or poor construction practices. Specifications applying to roadfill construction should also apply to landing construction.

Landings should be recognized as part of the transportation system and designed as such, not as an afterthought. If their locations are known in advance of the road survey, they may be designed and built as part of the road project.

Normally, however, the landing locations are not specified. The logger has the option of placing landings where he desires, so long as he meets contract requirements. Therefore, the backslope may be excavated to gain additional landing area. In this case, disposition of the excavated material becomes a problem. On gentle ground, where a fill slope will catch (usually under 60%), the excavated material may be used in a fill to gain the additional width needed to land the logs. After determining the landing width needed, a survey and design should be made to determine the quantity of excavation required to place the fill. The quantity should be adjusted by a compaction factor. On steeper slopes where fill placement is impossible, excavated material should be hauled to a designated waste area.

Excavation can be reduced by minimizing the activity on the landing. A swing system can be used to move the logs from the landing area. Logs can be decked along the road, eliminating the need for a large decking area next to the yarder.

Excavation may also be reduced by using split-level landings (Figure 3-4). An area above the road is leveled by the yarder. The logs are yarded uphill and landed on the road below the yarder. A heelboom loader or rubber-tired skidder may be used to keep the road open, deck logs, and load the trucks. Excavation required for a split-level landing depends upon ground conditions. If a natural bench occurs above the road, and access to the bench is on level ground, very little additional excavation will be required. On side slopes between 40% and 60%, a split-level landing requires approximately half the excavation of a single-level landing for the same effective width. Excavation savings include the material excavated for the access road to the upper level. With side slopes greater than 60%, access to the upper level becomes a problem. The amount of material excavated for the access road may be more than the amount excavated if a single-level landing were used.

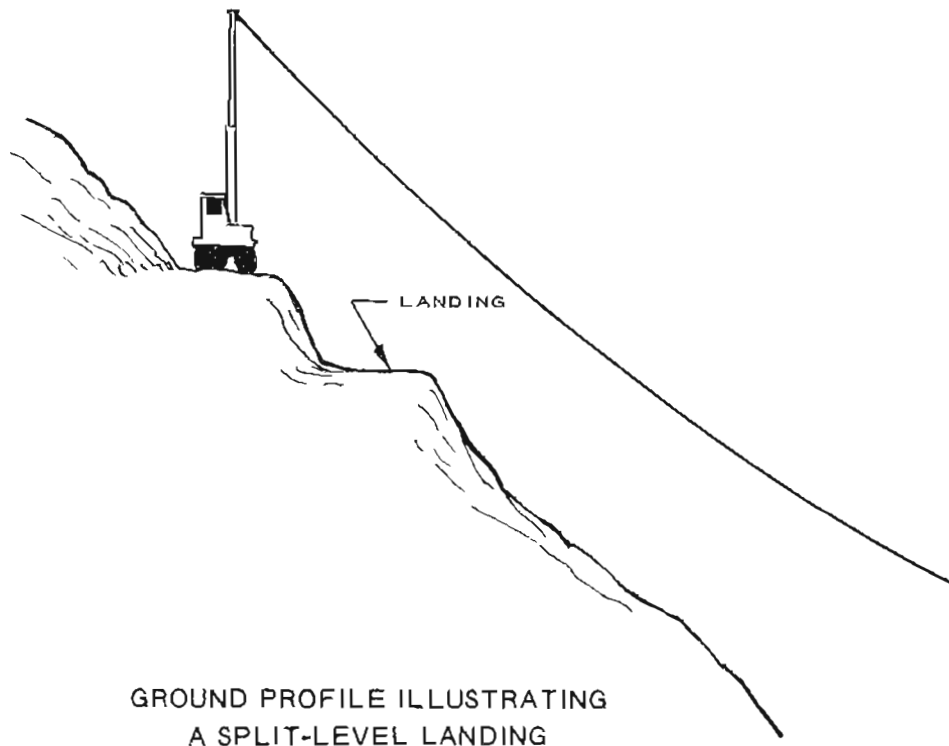

GROUND PROFILE ILLUSTRATING
A SPLIT-LEVEL LANDING

Figure 3-4

Landings should be constructed so that they provide a level and safe operating area. Most of the yarding and loading equipment is designed to operate from a near-level position. Leveling is especially important with a turntable or swing-boom machine such as a heelboom loader or a mobile running skyline yarder. Usually, this type of machine is equipped with outriggers to aid leveling. Large portable spar-yarders must be manually cribbed. If a 40-foot-long yarder is placed perpendicular to the centerline of a 3% grade road, the lower side of the yarder must be raised 4 inches to approximately level it. However, if the yarder is placed parallel to the centerline, the lower end of the yarder must be raised 14 inches. Therefore, the amount of cribbing needed depends upon yarder positioning. The area where the logs are landed should be level, so that they may be safely unhooked by the chaser.

Steep grades on the landing approach are undesirable. Quite often, the trucks must back up the grade during the loading operation and loading becomes more difficult. It is also difficult for trucks to maneuver and start after loading.

A road and landing system designed for the harvest cut may not meet the requirements for thinning or intermediate-cut yarding systems. A steep road grade to a clearcut landing may preclude using the road for later thinnings or intermediate cuts. It might be possible to set the yarder on the steep grade by building a pad for it, but loading would have to be accomplished on flatter ground.

CHAPTER 4 RIGGING AND WIRE ROPE

RIGGING PROCEDURES

All of today's cable systems must be rigged up before they can operate and rigged down after yarding is completed. Some are more complicated to set up than others. The Wyssen and Baco systems require three or four days of hard and tedious labor to string the skyline and make them operational. Some of the smaller systems require only one or two hours.

Span--the distance between the headspar and the tailhold--is one of the more important factors determining rigging difficulty. For example: The normal procedure in rigging a slackline is to lay the strawline out from the yarder by hand, around the edge of the unit to the first tailhold, and straight back to the yarder. The haulback cornerblocks and tailblock are rigged before the strawline is laid. The haulback line is then pulled through the strawline. Leaving the strawline and haulback connected, the skyline is then attached. The haulback pulls the skyline and the strawline out to the tailhold where the skyline is tied off. The strawline then pulls the haulback in to the yarder where the haulback and the mainline are attached to the carriage.

The procedure for changing roads in a clearcut unit may vary; however, the haulback line should not have to be re-strung for every road-change. Therefore, enough haulback line must be available to reach from the yarder, around the edge of the unit, through the haulback tailblock, and back to the yarder. If the span distance is too great, the haulback drum capacity may be insufficient to hold the line needed to reach around the unit. This may be the case when additional skyline is tagged on to gain more deflection. In this situation, additional haulback line may have to be spliced, or some other rigging procedure adopted.

The above example clearly points out the need for the Logging Engineer's working knowledge of rigging procedures in order that he may adequately lay out and appraise the sale. It is difficult to learn rigging by reading a description of a rigging situation. The only way to learn rigging and the problems associated with it is to be on the ground during the rigging job. It is relatively simple to diagram on paper the rigging procedures for a particular cable system. But in doing this it is also quite easy to over-simplify, for example, the problems of handling 2,000 feet of 1½-inch diameter skyline, or of installing a 200-pound block in a tailtree.

Why should a Logging Engineer or Sale Designer have a working knowledge of rigging procedures? Rigging has an important effect on the total cost of logging.

Rigging time must be added to logging time; thus, the unit costs for yarding increase. Consider two settings with the same total volume. Assume that the production rate on each setting is identical--the same machinery and crew will yard the volume in the same time. If three days are required to rig and yard the first setting and an additional day is required to rig the second setting because of rigging difficulties, costs per unit volume on the second setting will be one-third greater. In some instances, rigging may take longer than yarding the setting. This, alone, does not mean that the setting is economically unfeasible.

The above situation points out another fact. Volume per acre, alone, is not a good measure of whether a setting will be economically feasible. In some areas,

a minimum-volume-per-acre figure has been established as the economic unit for yarding with a certain system. The minimum volume per acre can only be established for a given market value of the timber and a specific logging cost. The economic feasibility of a setting must be determined by considering the total volume to be yarded, the job's total cost, and the value of the product being yarded.

Rigging time must be known when working with production figures. Most loggers report production based on yarding time, alone. If these production figures are used to predict costs on a proposed sale, rigging time must be added.

Rigging procedures vary. If a sale involves much rigging time compared with yarding time, the logger may use a special crew of two or three to do all the rigging. Duties include preparing the next landing, locating and notching guyline stumps, laying the strawline, rigging the headtree and tailtree (if required), preparing the skyline anchor, and setting out the haulback cornerblocks (if needed). By rigging ahead, the yarding crew is only out of production long enough to move the yarder and string the lines. That time will vary from one hour, for a small mobile yarder, to two days or more for a large standing skyline.

After the equipment is moved, the lines strung, and the yarding begun, the rigging crew moves the blocks and straps from the previous setting to the next setting ahead, and starts the cycle again. This system minimizes yarding delays. The rigging crew and yarding crew members are specialists in their jobs and should be more effective. However, there must be enough work to justify the special rigging crew. The problem can be solved if two or more sides are working in an area, which, of course, introduces a scheduling problem.

The procedure used by most loggers is to rig with part of the yarding crew. Before a road is completed, the hooktender or rigging-slinger takes one or two choker-setters and starts the pre-rigging operation. Strawline is laid, stumps are notched, and trees are rigged. After yarding, the crew moves to the next road, rigs the lines and begins yarding. The hooktender or rigging-slinger then moves the miscellaneous blocks and straps to the succeeding setting. With this procedure production drops when part of the yarding crew is rigging the next road.

The Sale Designer must know the required hardware and equipment to rig the system so adequate appraisal allowances can be made. Following is a list of hardware and equipment required to rig a tailtree for a system using a 1-inch skyline.

<u>Hardware</u>	<u>Equipment</u>
3 Cornerblocks	2 sets Climbing Spurs
1 Bullblock	2 Climbing Belts
1 Riggers Block	2 Climbing Ropes
1 Skyline Knockout Pin Shackle	2 Splicing Ropes
2 Guyline Sleeves	1 Rigger's Maul
600 feet of 1-inch diameter Guyline	1 Splicing Hammer
1½-inch diameter Strap for Tailtree Block	1 Rigger's Bar
4 ¾-inch diameter Straps for Rigger and Haulback Blocks	Ax
6 Cable Clamps	Chainsaw
	Chainsaw Wedges
	Chain Hoist
	Pass Chain

Two sets of hardware are needed, so that one tailtree may be rigged ahead. In addition, tree plates, or protective devices may be required to protect live standing trees from being girdled. Nylon belting may also be used to hang the tailtree block if the skyline is 7/8-inch diameter or less.

A list of equipment similar to the above should be made for the more common rigging situations. It will aid the Sale Designer in making economic comparisons.

The Sale Designer must be familiar with the safety codes applying to logging operations for the state in which he is working and design should be based on rigging practices complying with that state's safety code. Conflicts often occur at the back end of a setting. For example, a sale may be designed for a 1½-inch diameter skyline with tailtrees along the back edge of the unit. The safety code in Oregon, for instance, specifies that the tailtree be topped and that guylines not be anchored to live standing trees. Therefore, provisions must be made in the sale design to allow these trees to be cut.

WIRE ROPE

Wire rope is described, first, by the number of strands per rope, and then by the number of wires per strand. For example: 6 x 19 means 6 strands composed of 19 wires per strand. The number of wires per strand has a direct relationship with flexibility and resistance to abrasion. In general, the more wires per strand, the more flexible the rope and the lower its resistance to abrasion. A 6 x 19 wire rope has high resistance to abrasion, but low flexibility. This classification is commonly used for skylines, haulback lines, and mainlines.

Wire rope is further defined by grade. Strength and toughness are two characteristics needed in wire rope for logging. There are many grades, but the two most commonly used in the logging industry are Improved Plow Steel and Extra Improved Plow Steel. Extra Improved Plow Steel has a very high carbon content, providing it strength. Improved Plow Steel has a high carbon and manganese content which makes it hard and abrasion-resistant.

Wire ropes are also manufactured in different "lays". The term "lay" means the direction in which the wires are laid into strands, or strands into rope. The most common lays used in logging are Right Regular Lay and Right Lang Lay.

If the strands in the rope are laid to the right, the rope is known as Right Lay. If the wires in the strands are spirally laid in an opposite direction to the rope lay, the rope is classified as Regular Lay. If the wires in the strands are laid in the same direction as the strands, the rope is known as Lang Lay. Lang Lay Rope is easy to recognize because the outer wires appear to run at an angle to the rope axis. The outer wires in a Regular Lay appear to run in the same direction as the rope axis. Lang Lay ropes are generally more flexible and have more resistance to abrasion and bending fatigue than do Regular Lay ropes.

The core of the wire rope supports the strands and maintains the position of the strands during bending. There are two types of cores: Fiber Core, made of sisal or synthetic fiber, and Independent Wire Rope Core (IWRC) made of a separate 7 x 7 wire rope. Independent Wire Rope Core is recommended for heavy-duty service such as logging.

In summary, a wire rope is defined by specifying construction, grade, lay, and core. A typical designation for a logging rope would be 6 x19, Extra Improved Plow Steel, Regular Lay, IWRC.

The weakest point in a cable system often occurs where two cables are connected or where an attachment has been placed on the end of a cable for anchoring. Table 4-1 lists some of the splices and end attachments used in logging, and their efficiency if they are correctly installed.

<u>Attachment or Splice</u>	<u>Efficiency (% of Rope Strength)</u>
Long Splice	100
Sockets; zinc, swaged or pressed	100
Sockets; wedged	70-90
Clips	80
Spliced eye and thimble	
1/4" and smaller	90
5/16" - 7/16"	88
3/8"	88
1/2"	86
5/8"	84
3/4"	82
7/8" - 1-1/2"	80
Spliced eye without thimble	Indeterminate because of flattening of strands

Table 4-1

A wire rope loses some of its strength when it is bent around a sheave. Strength-loss is dependent upon the sharpness of the bend and the relative sizes of the sheave and rope. Strength-loss is not dependent upon degrees of bend. Table 4-2 gives the strength efficiency for ropes bent around sheaves of a given diameter as compared with the same rope when straight.

STRENGTH EFFICIENCY UNDER STATIC LOAD

When Sheave Diameter is:	Efficiency of Rope is:
10 times rope diameter	79% of strength of straight rope
12 times rope diameter	81% of strength of straight rope
14 times rope diameter	86% of strength of straight rope
16 times rope diameter	88% of strength of straight rope
18 times rope diameter	90% of strength of straight rope
20 times rope diameter	91% of strength of straight rope
24 times rope diameter	93% of strength of straight rope
30 times rope diameter	95% of strength of straight rope

Table 4-2
(Oregon Safety Code, Chapter 16)

Yarder specifications give the drum capacities for the maximum-size wire-rope handled. It is often possible to install a smaller-diameter wire-rope to gain additional length. Table 4-3 provides a "K" value to determine a drum capacity for a wire rope diameter, knowing the drum capacity for a given wire rope diameter.

Example : If a drum holds 1,450 feet of 1-3/8-inch diameter rope, how much 1-inch diameter rope will it spool?

Solution: From Table 4-3, the K value for 1-3/8" wire rope is 0.127, and the K value for 1" wire rope is 0.239. Therefore,

$$\frac{1,450'}{K(1-3/8)} \times K(1'') = \text{Capacity of 1"}$$

or

$$\frac{1,450'}{0.127} \times 0.239 = 2,729 \text{ feet of 1" diameter rope}$$

The approximate drum capacity can be determined by using Figure 4-1. This figure can also be used to determine the weight of a given length of line.

WIRE ROPE WEIGHTS, STRENGTHS, AND K VALUES
6 x 19, 6 x 21, or 6 x 25 IWRC*

Diameter (Inches)	K**	Weight Lb/Ft	Extra-Improved Plow Steel	
			Safe Working Load KIPs (Safety Factor = 3)	Breaking Strength KIPs
1/4	3.29	.116	2.27	6.80
5/16	2.21	.18	3.51	10.54
3/8	1.58	.26	5.0	15.1
7/16	1.19	.35	6.8	20.4
1/2	.925	.46	8.9	26.6
9/16	.741	.59	11.2	33.6
5/8	.607	.72	13.7	41.2
3/4	.428	1.04	19.6	58.8
7/8	.308	1.42	26.5	79.6
1	.239	1.85	34.5	103.4
1-1/8	.191	2.34	43.3	130.0
1-1/4	.152	2.89	53.3	159.8
1-3/8	.127	3.50	64.0	192.0
1-1/2	.107	4.16	76.0	228.0
1-5/8	.0886	4.88	88.0	264.0
1-3/4	.0770	5.67	102.0	306.0
1-7/8	.0675	6.50	116.0	348.0
2	.0597	7.39	132.0	396.0

*Independent Wire Rope Core

**This value gives only approximate capacities because it is based on a constant tension when spooling the wire, and the same number of wraps of rope in each layer.

Table 4-3

Figure 4-1

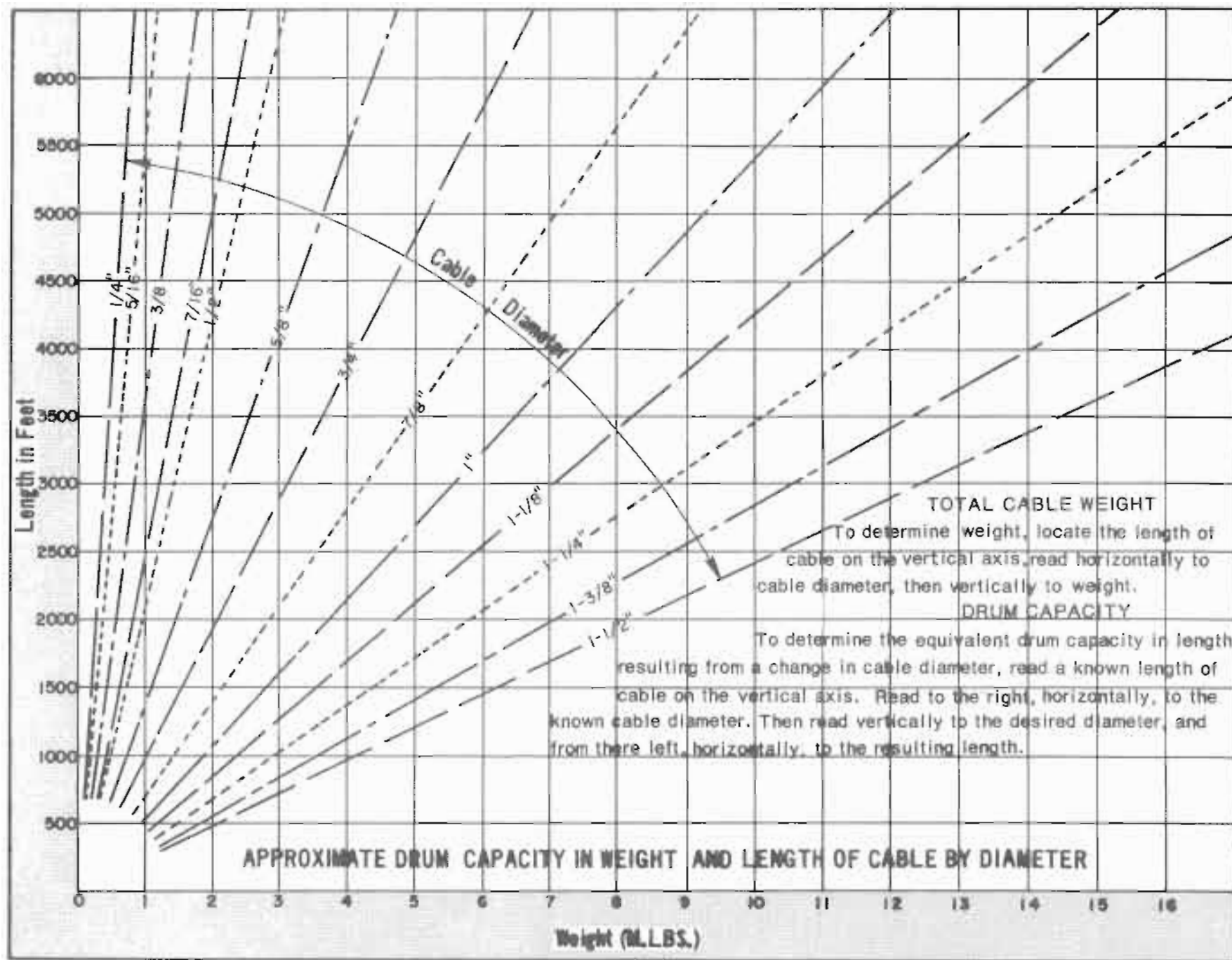

CHAPTER 5 MECHANICS OF ANCHORING

Good anchoring cannot be overemphasized in planning a skyline operation. There have been many instances where carriages and other equipment have been damaged or destroyed because of anchor failures.

Presently, the only way to estimate an anchor's capacity is by experience--usually gained the hard way. Three types of anchors are commonly used: Stumps, deadman anchors, and rockbolts.

Considerations in anchor selection are soil type and depth, stump diameter and density, rock type, magnitude of the load to be applied to the anchor, and cost of rigging the anchor. Stumps are generally more economical to rig; but in areas of shallow soils and small or scattered stumps, rockbolts or deadman anchors may be more economical.

The cost of rigging an anchor depends to a great extent on accessibility. In an area roaded on the ridges with no access to the canyon bottoms, many hours, or even days, may be required to hand-carry rigging and support equipment to the anchor location. Actually rigging the anchor may take only a few hours.

Stump anchors are usually easier to rig at the bottom of a unit than at the top (providing that they are equally accessible) because of less tension, deeper soils, and generally larger stumps. When large stumps are not available, a series of smaller stumps may be rigged to provide suitable anchorage. (figure 5-3).

Since there is no present method of predicting load-bearing capacity of stumps, this chapter is limited to the mechanics of rigging stump anchors. However, a few general rules concerning the holding power of stumps are in order:

1. Holding power tends to increase with soil depth.
2. Holding power tends to increase with soil density.
3. Holding power increases approximately with the square of the stump diameter. (Wyssen Skyline Manual)
Example: A 48-inch diameter stump will hold approximately four times as much as a 24-inch stump.
4. Stumps have greater holding strength on uphill pulls than on downhill pulls.
5. Holding power tends to decrease as soil moisture increases.

As indicated, the skyline should pull uphill on a stump whenever possible because the stumps on a facing hillside generally have less root structure upslope and are more easily tipped out when pulled downhill. To anchor at the top of a ridge, a more secure hold may be achieved by going over the break of the ridge, as shown in Figure 5-1. In figure 5-1, the pull on stump No. 1 would be on the weaker root structure, where the pull on stump No. 2 would be on the stronger root structure.

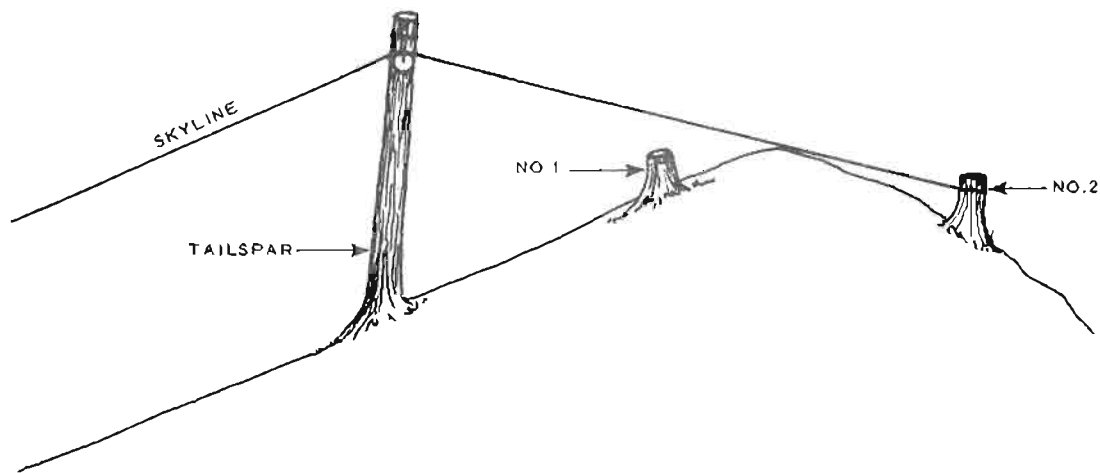

Figure 5-1. - Stump anchor at ridgetop

RIGGING PRACTICES

Before explaining the mechanics of stump anchors, some of the general rigging practices should be noted:

1. Notch stumps to prevent lines from slipping off.
2. When making multiple stump anchors, use stumps which are aligned as closely as possible with the skyline.
3. To achieve better load distribution on multiple stump anchors, use blocks on the tieback lines rather than a cable wrapped around the stump.
4. Use at least one tieback stump on main anchor stumps--even large, deep-rooted stumps. The tieback stump helps prevent the main stump from working loose when it is subjected to the large dynamic loads common in skylines.
5. For a series of stumps rigged as shown in figure 7, the line tension between the main stump and the second stump will be approximately one-third of the skyline tension. Additional stumps will have negligible load.

The above rigging practices are not new but have been listed because experience proved they were necessary, although the reasons were not always known. This handbook will explain some of the "reasons why".

Two typical rigging plans are shown in figures 5-2 and 5-3. The three stump anchors of figure 5-2 can be used where stumps are large and strong; but in areas of small or weak stumps, the multi-stump anchor employing as many as 30 stumps may be used (figure 5-3).

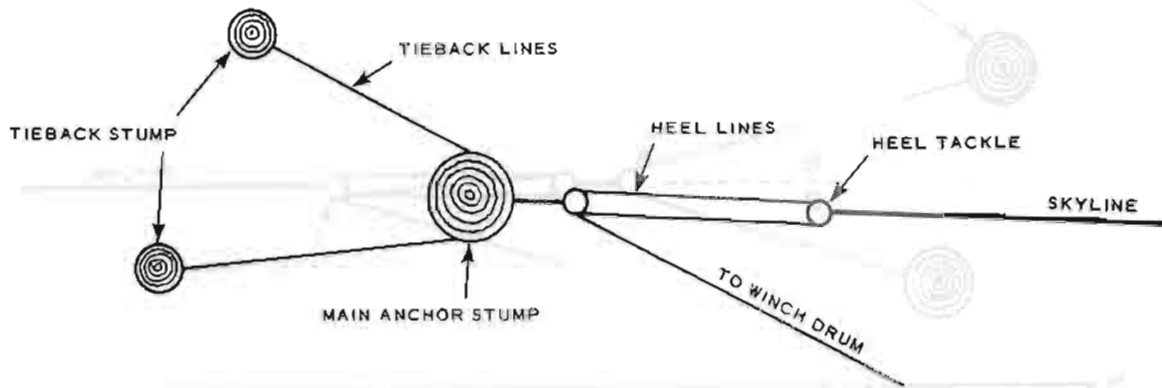

Figure 5-2. - Plan view of a typical skyline anchor using large stumps.

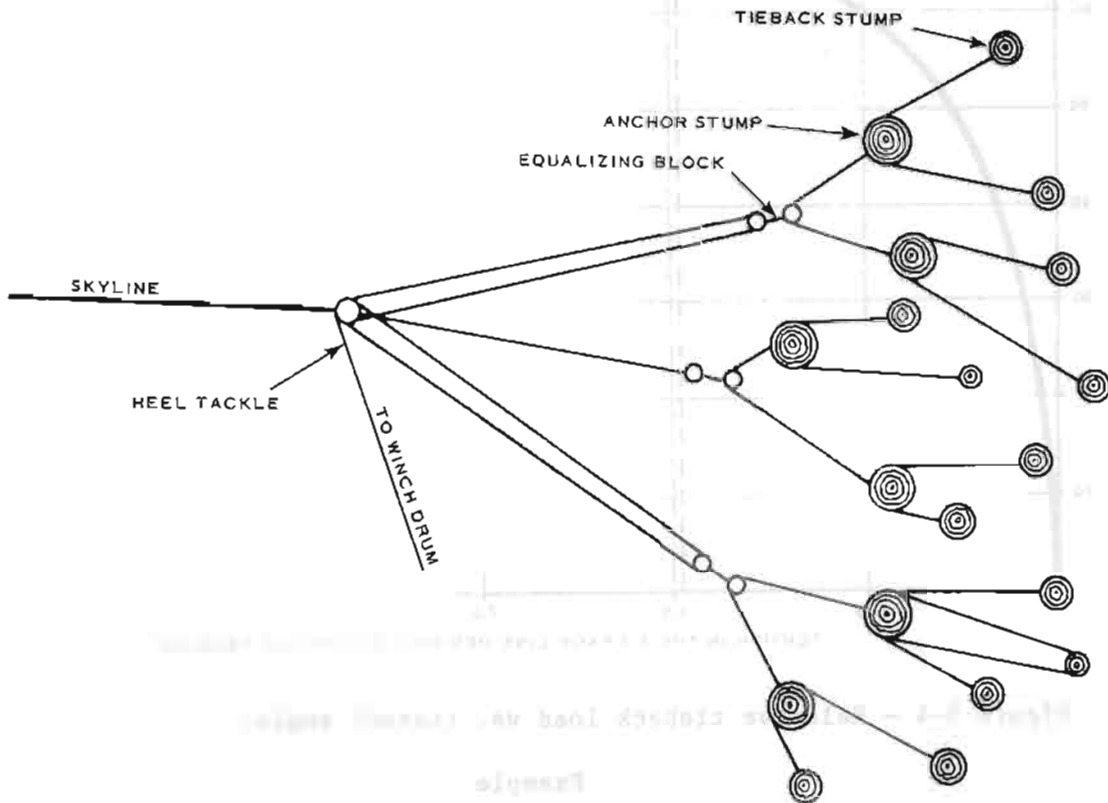

Figure 5-3 - Plan view of a typical skyline anchor using small stumps.

One of the important considerations, and one frequently overlooked, is the relationship between the angle made by the tieback lines and the skyline and the actual load on the stump as shown in figure 5-4.

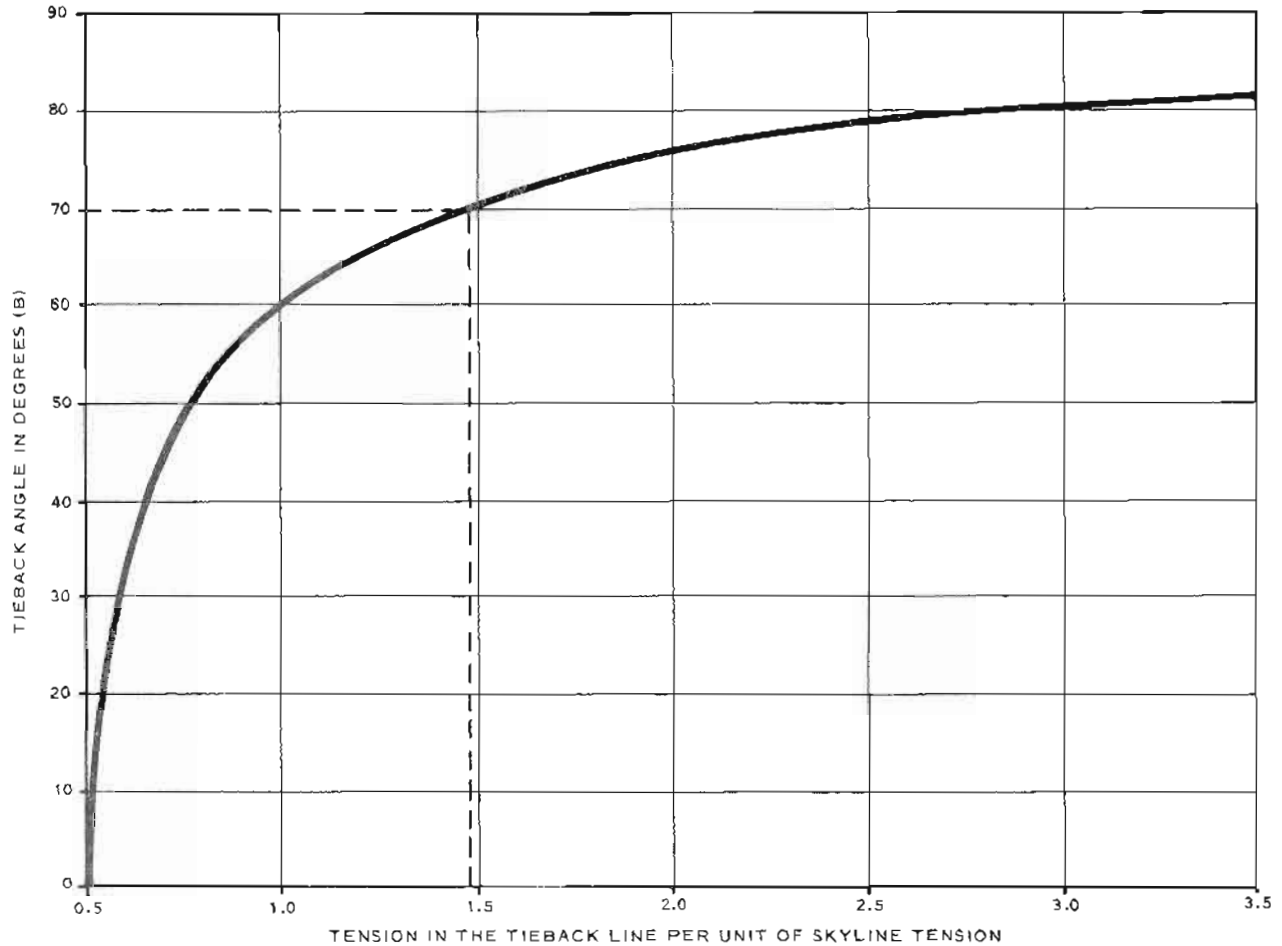
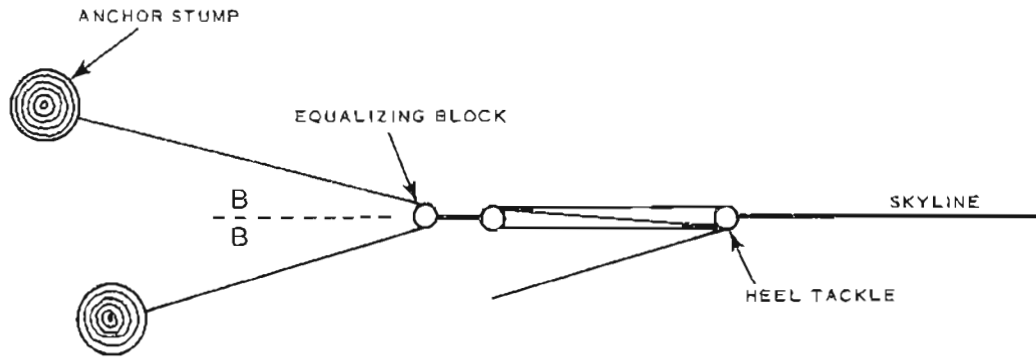

Figure 5-4 - Relative tieback load vs. tieback angle.

Example

Find: The load on each stump when the skyline tension = 50 kips and $B = 70^\circ$.

Solution: From the graph for $B = 70^\circ$, tension per unit of load = 1.47. Load on each stump = $50 \times 1.47 = 73.5$ kips.

The graph shown in figure 5-4 was developed from the following analysis of the two-stump anchor shown.

A summation of forces in both the x and y directions produces:

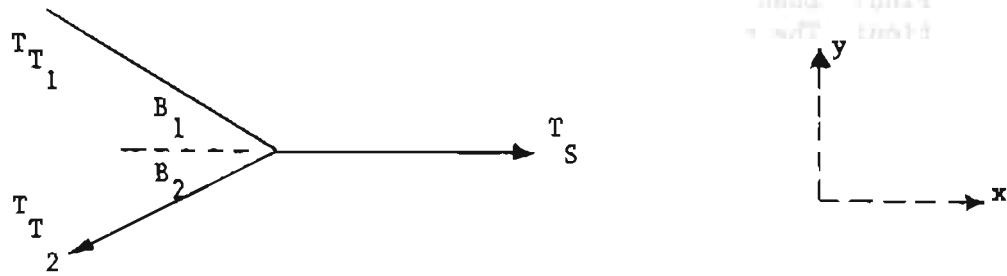

T_S = tension in skyline

T_T = tension in tieback line

$$\Sigma F_y = 0 \quad T_{T1} \sin B_1 - T_{T2} \sin B_2 = 0$$

$$T_{T1} = T_{T2} \quad \text{Hence, } \sin B_1 = \sin B_2 \quad \text{and } B_1 = B_2$$

Eq. 5.1

$$\Sigma F_x = 0 \quad T_S - T_T \cos B - T_T \cos B = 0$$

$$T_S = 2T_T \cos B$$

$$T_T = \frac{T_S}{2 \cos B}$$

Eq. 5.2

From equation 5.2, it can be seen that:

When B is small, $\cos B \rightarrow 1$ and

$$T_T = \frac{1}{2} T_S$$

When B is large, $\cos B \rightarrow 0$ and small T_S produce a very large T_T .

As the example of figure 5-4 indicates, a 50-kip skyline tension transferred from the skyline to a pair of stumps produces a force of nearly 74 kips on each stump when the tieback is at a 70° angle to the skyline. This is nearly 50% more load per stump than there is tension in the skyline. The importance of minimizing the tieback angle is illustrated in figures 5-5a and 5-6 where force reductions on the stump of 20% and 55%, respectively, are achieved by reducing the angle of the tieback.

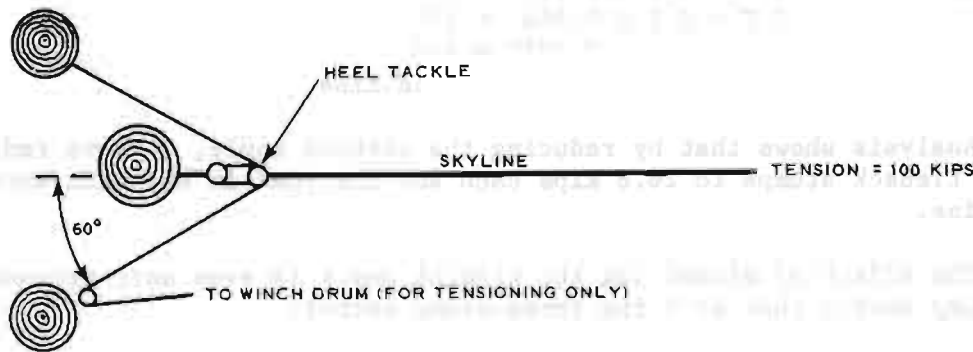

Figure 5-5a - Plan view of a typical three-stump anchor.

Given: Stump anchor plan shown in figure 5-5a, 100 kip-skyline tension.
 Find: Load on all stumps.
 Solution: The problem can be solved by drawing a free body diagram (figure 5-5b) and balancing forces as follows:

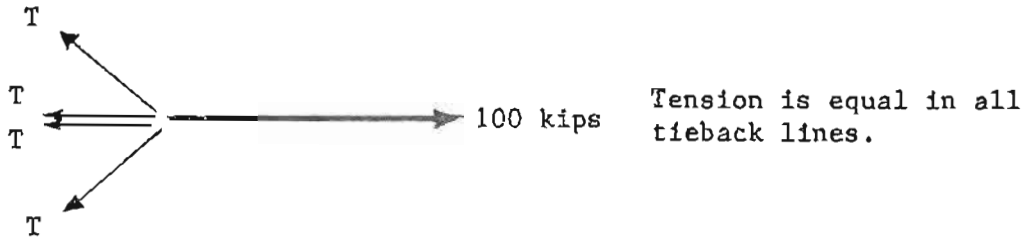

Figure 5-5b.- Force diagram.

Summation of forces shown by vectors in figure 5-5b.

$$\begin{aligned} \Sigma F = 0 \quad T + T + T \cos 60^\circ + T \cos 60^\circ - 100 &= 0 \\ 2T + 0.5T &= 0.5T = 100 \\ 3T &= 100 \\ T &= 33.3 \end{aligned}$$

Therefore, the tension in the tieback stump, the load on each stump is 33.3 kips. There are two tieback lines to the main anchor stump; therefore, the stump has to resist a load of 66.6 kips.

Now in comparison, if the tieback angle is reduced by lengthening the heel lines (figure 5-5c) we get the following:

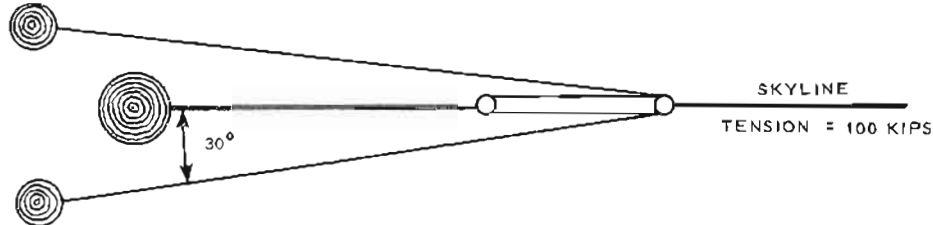

Figure 5-5c. - Plan view of three-stump anchor with long heel lines.

Following the same procedure and summing forces, we get:

$$\begin{aligned} \Sigma F = 0 \quad 2 T + 2 T \cos 30^\circ &= 100 \\ 2 T + 2 T \times 0.866 &= 100 \\ 3.732T &= 100 \\ T &= 26.8 \text{ kips} \end{aligned}$$

Analysis shows that by reducing the tieback angle, we have reduced the load to the tieback stumps to 26.8 kips each and the load on the main anchor stump to 53.6 kips.

The effect of minimizing the tieback angle is even more pronounced with a two-stump anchor than with the three-stump anchor.

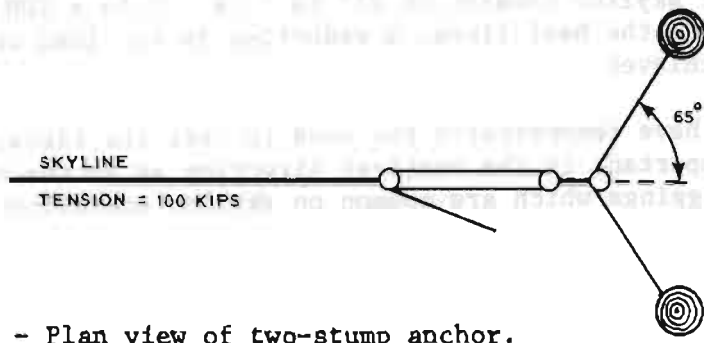

Figure 5-6a. - Plan view of two-stump anchor.

Given: The two-stump anchor shown and a 100-kip skyline tension (Figure 5-6a)

Find: Load on all stumps.

Solution: The problem can be solved by drawing a free body diagram and balancing forces (Figure 5-6b).

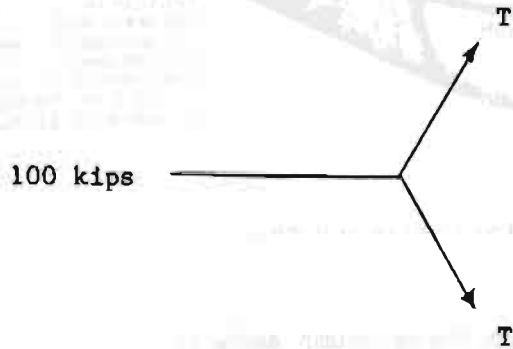

Figure 5-6b. - Force diagram.

$$\begin{aligned} \Sigma F = 0 \quad 2 T \cos 65^\circ - 100 &= 0 \\ 2 T 0.423 &= 100 \\ 0.846 T &= 100 \\ T &= 118.3 \text{ kips} \end{aligned}$$

The load on each stump is then 118.3 kips

This problem can be solved with the aid of the graph of figure 5-4: Enter the graph with 65° and determine that a unit tieback load will produce 1.18 units of tension in the tieback line, or $100 \times 1.18 = 118$ kips of load on each stump.

Now, again in comparison, reduce the tieback angle to, say, 22° (figure 5-6c).

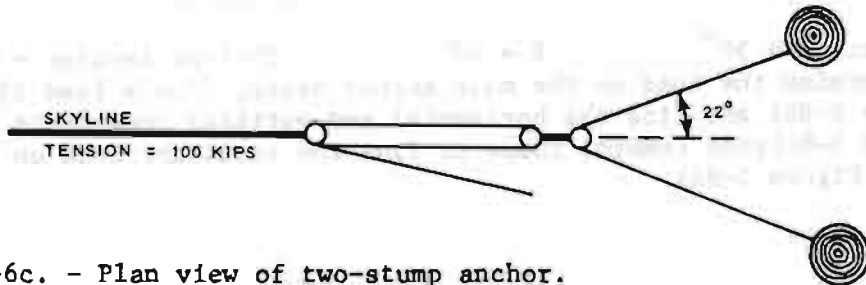

Figure 5-6c. - Plan view of two-stump anchor.

The problem can be solved by use of the graph of figure 5-4. The tieback tension per unit of skyline tension at 22° is 0.54. $0.54 \times 100 = 54$ kips. As a result of lengthening the heel lines, a reduction in the load on the stumps of 55 percent has been achieved.

The examples have demonstrated the need to keep the tieback angle to a minimum. This is as important in the vertical direction as in the horizontal. Figures 5-7 and 5-8 show riggings which are common on skyline operations.

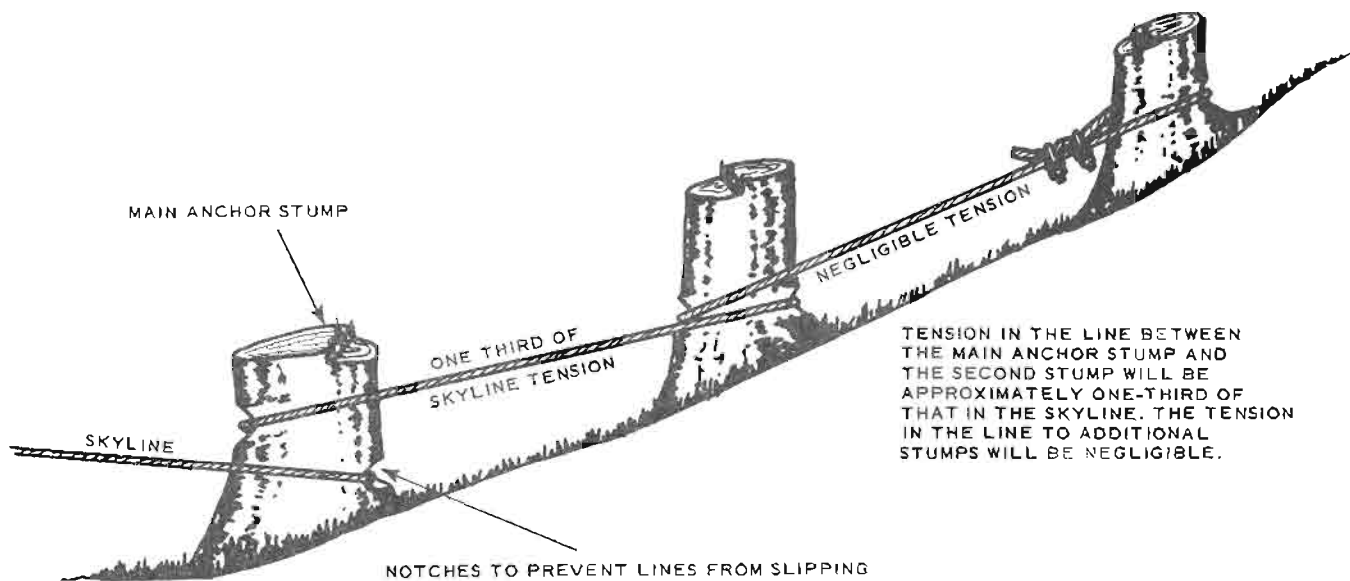

Figure 5-7. - Profile of common three-stump anchor.

An analysis of figure 5-8a will show why this rigging method should be used with caution on steep slopes.

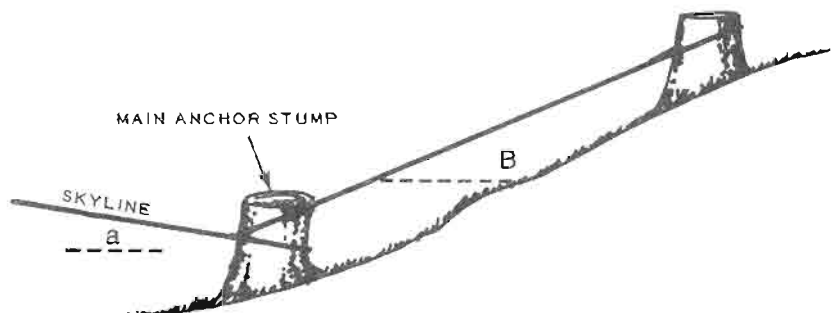

Figure 5-8a. - Profile of a common two-stump anchor.

Example: $a = 30^\circ$ $B = 60^\circ$ Skyline tension = 60 kips
 To determine the load on the main anchor stump, draw a load diagram (Figure 5-8b) and find the horizontal and vertical components of load, (Figure 5-8c) then combine these to find the resultant load on the stump (Figure 5-8d).

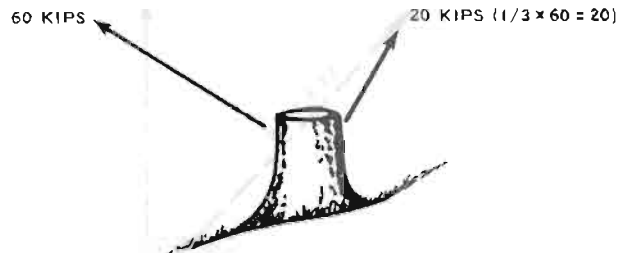

Figure 5-8b. - Load diagram.

Horizontal component of skyline tension is
 $60 \times \cos 30^\circ = 60 \times 0.866 = 52.0$ kips

Vertical component of skyline tension is
 $60 \times \sin 30^\circ = 60 \times 0.5 = 30$ kips

Horizontal component of tieback tension is
 $20 \times \cos 60^\circ = 20 \times 0.5 = 10$ kips

Vertical component of tieback tension is
 $20 \times \sin 60^\circ = 20 \times 0.866 = 17.32$ kips

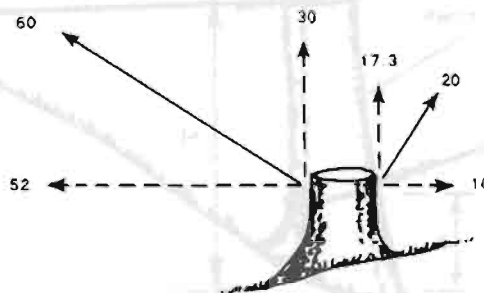

Figure 5-8c. - Load components.

Combining the skyline and tieback tensions, both horizontally and vertically yields:

$$\Sigma F_x = 10 - 52 = -42.0$$

$$\Sigma F_y = 30 + 17.3 = 47.3$$

Now these horizontal and vertical forces can be combined to produce one resultant force on the stump.

The resultant of the horizontal and vertical forces can be found by use of the Pythagorean theorem where:

$$\text{Resultant load} = [(\text{vert. comp.})^2 + (\text{horiz. comp.})^2]^{\frac{1}{2}}$$

$$= [(47.3)^2 + (42.0)^2]^{\frac{1}{2}}$$

$$= [2237.3 + 1764.0]^{\frac{1}{2}}$$

$$= [4001.3]^{\frac{1}{2}}$$

$$= 63.3 \text{ kips}$$

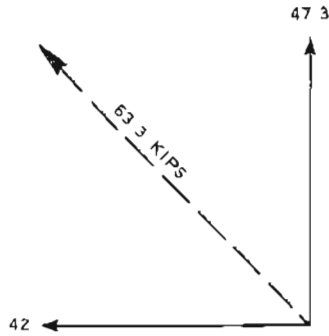

Figure 5-8d. - Resultant load.

It has been demonstrated that the actual load on the stump is 63.3 kips, or 3.3 kips more than the skyline tension. Clearly, some other rigging configuration is called for. An alternate method of rigging to reduce the load on the stump is shown in figure 5-9a.

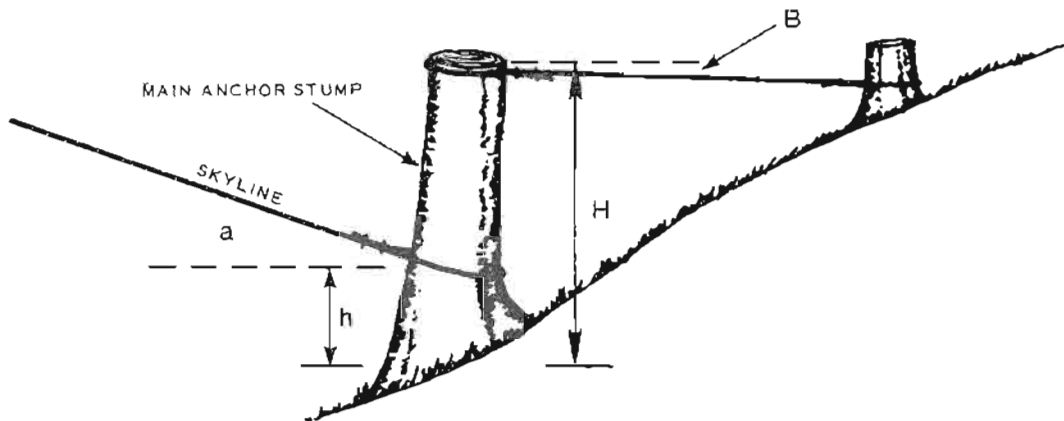

Figure 5-9a. - High stump anchor.

To demonstrate the advantages of rigging with a high stump, assume the following:

$a = 30^\circ$ $B = -10^\circ$ $h = 4$ feet $H = 8$ feet
 Skyline tension = 60 kips (see figure 5-9b)

The same procedure that was used to solve for the load on the stump of figure 5-8 will be used.

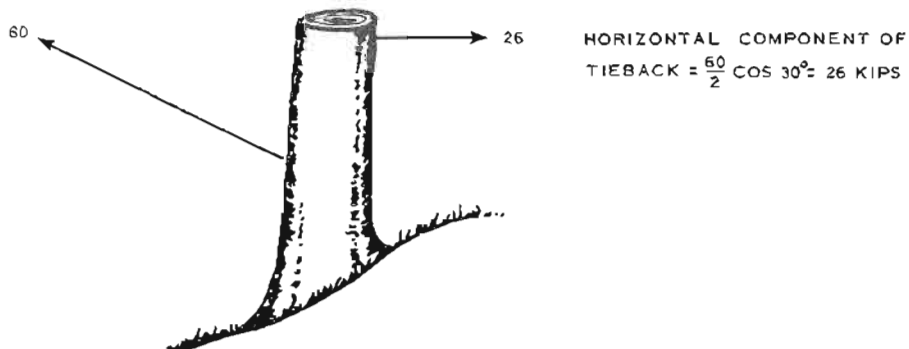

Figure 5-9b. - Skyline and tieback forces on the stump.

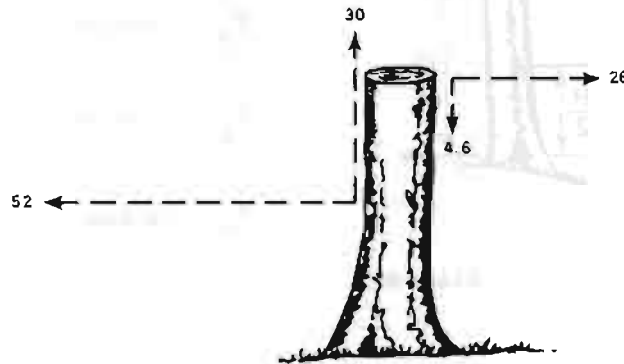

Figure 5-9c. - Horizontal and vertical components of load.

Horizontal component of skyline tension = $60 \cos 30^\circ = 52$ kips

Vertical component of skyline tension = $60 \sin 30^\circ = 30$ kips

Vertical component of tieback tension = $26 \tan 10^\circ = 4.6$ kips

Summing the horizontal and vertical component, we get:

Horizontal $26 - 52 = -26$ kips

Vertical $30 - 4.6 = 25.4$ kips

The resultant of these forces will be the load on the stump (Figure 5-9d).

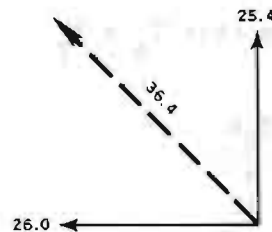

Figure 5-9d. - Resultant load diagram.

$$\begin{aligned} \text{Resultant} &= [(25.4)^2 + (26.0)^2]^{\frac{1}{2}} \\ &= [(645.2) + (676)]^{\frac{1}{2}} \\ &= [1321.2]^{\frac{1}{2}} \\ &= 36.4 \text{ kips} \end{aligned}$$

In the two examples just examined, rigging to a tall stump with tiebacks achieved a reduction in the load on the main anchor stump of 43%. It should be pointed out that several tieback stumps could have been rigged, but for the sake of simplicity, only one was used.

Rigging in this manner (fig. 5-9a) introduces a large bending moment in the stump. The bending moment will increase with increasing stump height and decrease with increasing stump diameter. As a result, there will be a limiting value of stump height for a particular load and stump diameter.

To find the limiting height, consider the load diagram (fig. 5-9e). The maximum bending moment will occur when the skyline is tied one-half way from the tieback line to the ground.

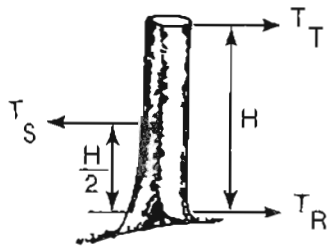

T_T = TENSION IN TIEBACK IN POUNDS

T_S = TENSION IN SKYLINE IN POUNDS

T_R = TENSION TAKEN BY THE ROOTS

Figure 5-9e. - Load diagram.

Assumptions:

1. For small skyline slopes, the horizontal component of tension is approximately equal to the skyline tension. This assumption will produce conservative results.
2. The stump will act as a simple beam since the stump will not deflect enough for the roots to apply a resisting moment.

$$\begin{aligned} \Sigma M_{T_R} = 0 \quad T_S \frac{H}{2} - T_T H = 0 \\ T_T = \frac{1}{2} T_S \end{aligned} \quad \text{Eq. 5.3}$$

$$\Sigma F_x = 0 \quad T_S - T_T - T_R = 0$$

$$\text{Since } T_T = \frac{T_S}{2} \text{ it follows that } T_R = \frac{T_S}{2} \quad \text{Eq. 5.4}$$

$$\text{Moment in the stump} = \frac{T_S H}{4} \quad \text{Eq. 5.5}$$

$$\text{The resisting moment} = \frac{\sigma I}{c} \quad \text{Eq. 5.6}$$

Where σ = allowable fiber stress

I = moment of inertia

c = distance from the neutral axis to the outer fiber

$$I = \frac{\pi D^4}{64} \text{ and } c = \frac{D}{2}$$

Where D = diameter of the stump in inches at the point where the skyline is tied on.

Setting equation 5.5 equal to equation 5.6 and solving, we get

$$\frac{T_S H}{4} = \frac{\sigma I}{c} \text{ and } H = \frac{80\pi D}{64 T_S} = \frac{\pi D}{8 T_S}$$

Figure 5-10 is a graph of this equation with $\sigma = 1,200$ p.s.i.

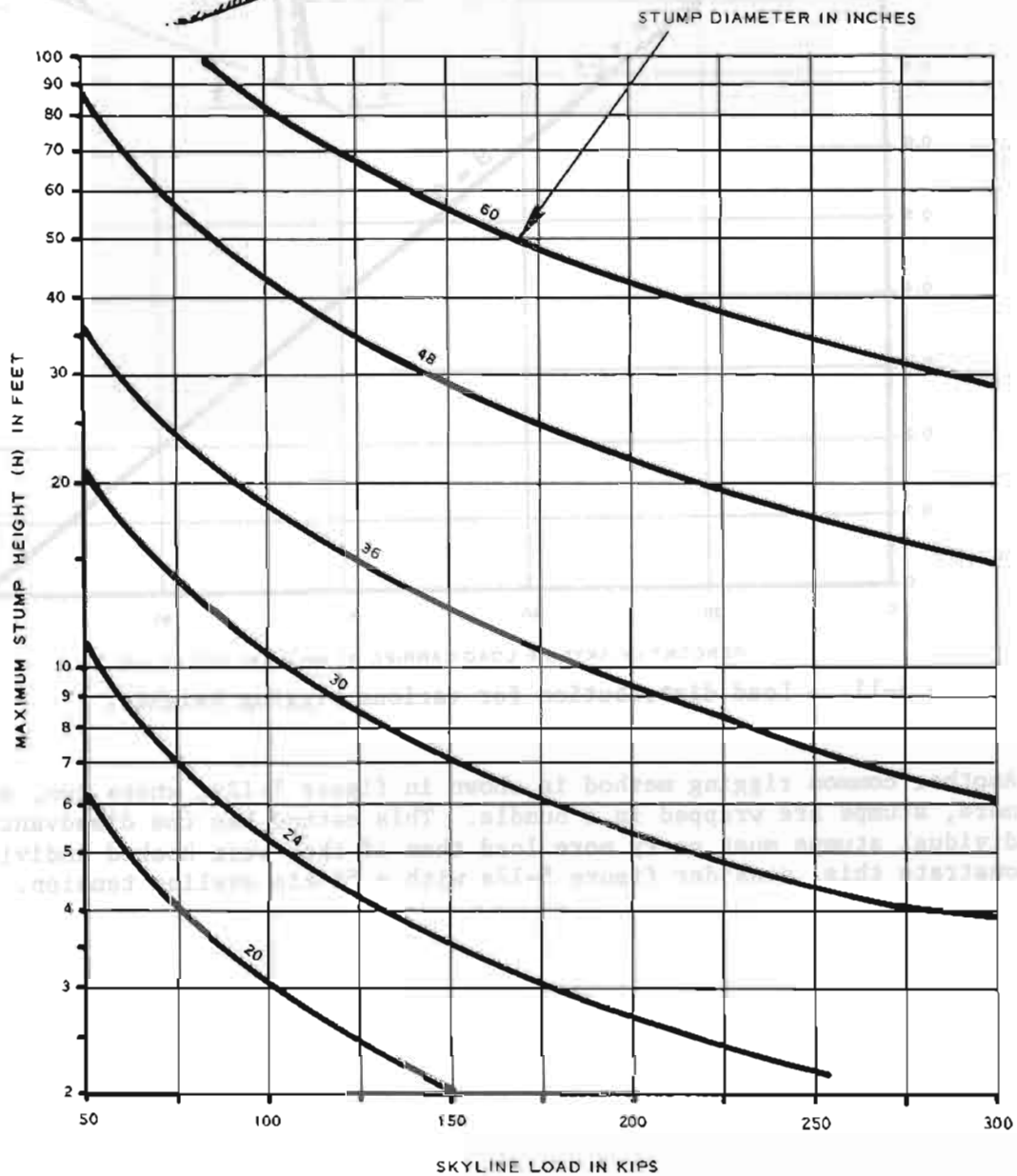
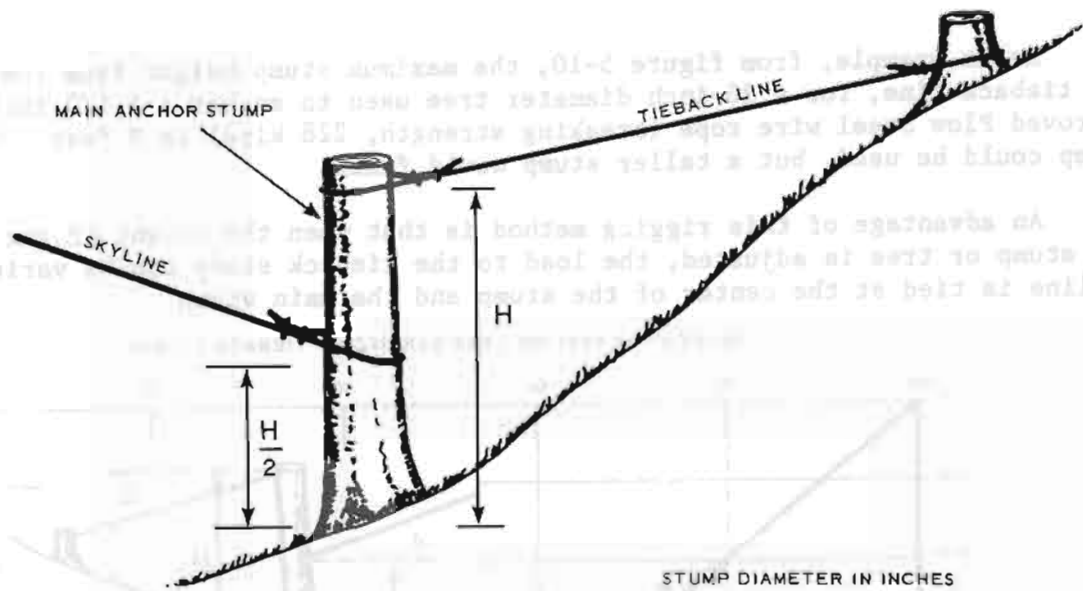

Figure 5-10 - Maximum stump height vs. load and stump diameter

As an example, from figure 5-10, the maximum stump height from the ground to the tieback line, for a 36-inch diameter tree used to anchor a 1-1/2-inch Extra-Improved Plow Steel wire rope (breaking strength, 228 kips) is 8 feet. A shorter stump could be used, but a taller stump would fail.

An advantage of this rigging method is that when the height of the skyline on the stump or tree is adjusted, the load to the tieback stump can be varied when the skyline is tied at the center of the stump and the main stump.

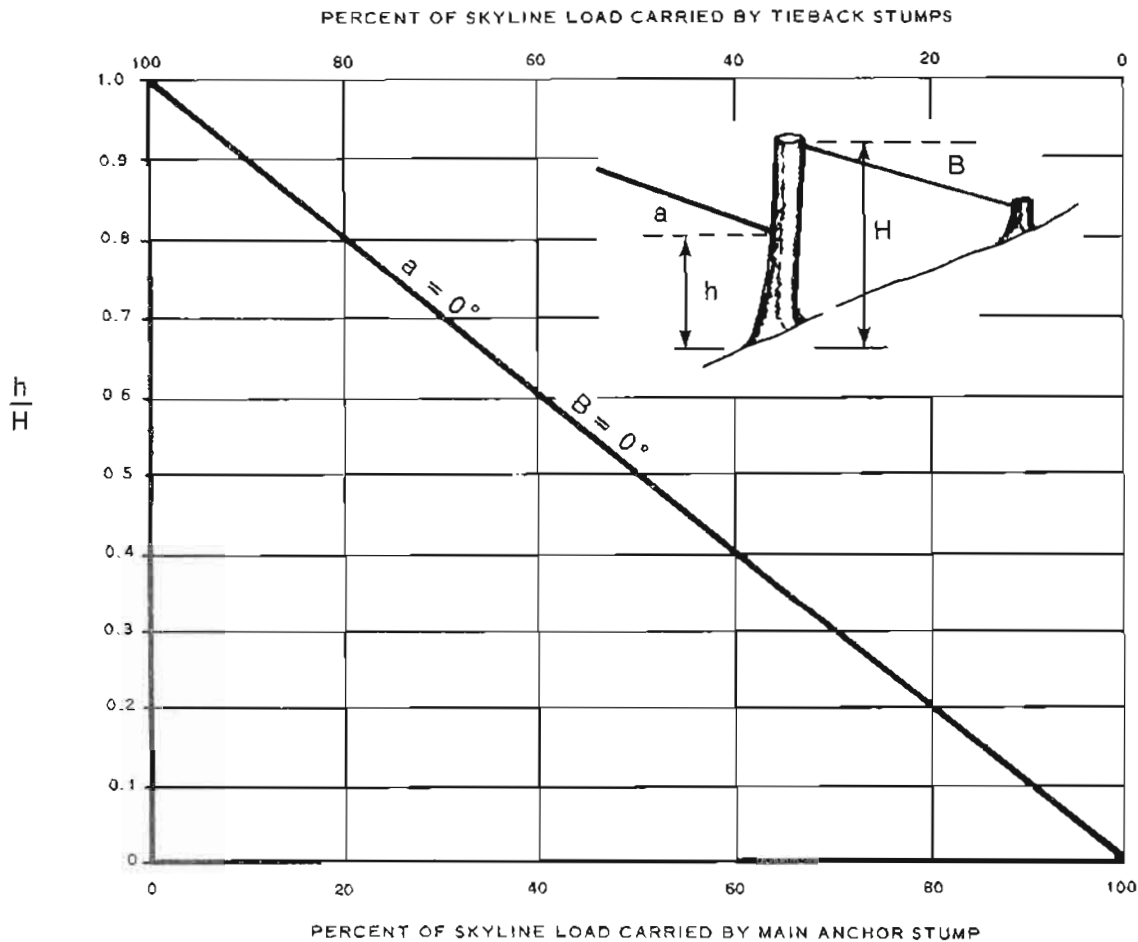

Figure 5-11. - Load distribution for various rigging heights.

Another common rigging method is shown in figure 5-12a, where two, and sometimes more, stumps are wrapped in a bundle. This method has the disadvantage that the individual stumps must carry more load than if they were hooked individually. To demonstrate this, consider figure 5-12a with a 50-kip skyline tension.

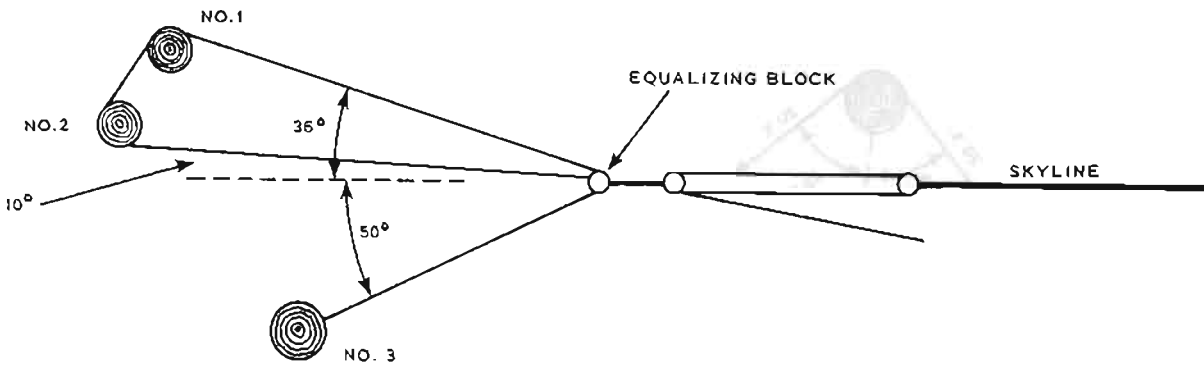
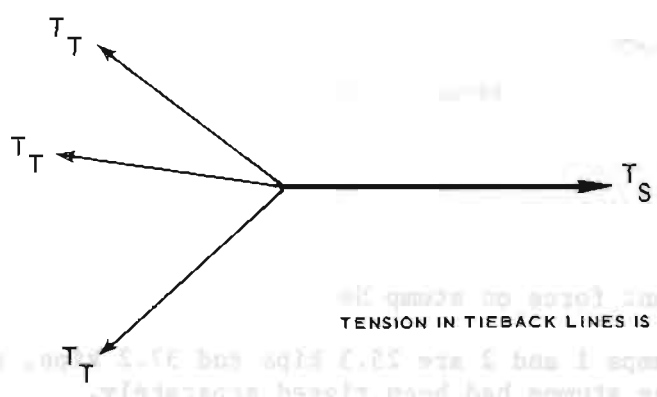

Figure 5-12a - Plan view of stump anchor with two stumps bundled together.

Use a force diagram and sum forces (figure 5-12b).



TENSION IN TIEBACK LINES IS APPROXIMATELY EQUAL

Figure 5-12b - Force diagram.

$$\Sigma F_x = 0 \quad T_T \cos 50^\circ + T_T \cos 10^\circ + T_T \cos 36^\circ - T_S$$

$$(.64279 + .98481 + .80902) T_T = T_S$$

$$2.4366 T_T = T_S \text{ or}$$

$$T_T = .4104 T_S$$

Substituting $T_S = 50$ kips

Then $T_T = 20.5$ kips

Stump No. 3 has one line pulling on it, so the load on stump No. 3 is 20.5 kips.

On the other hand, stumps 1 and 2 have, in fact, two lines pulling on them, as shown in figures 5-12c and 12d.

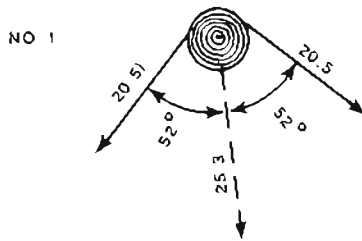

$$\text{RESULTANT FORCE} = 2(20.5) \cos 52^\circ = 25.3 \text{ KIPS}$$

Figure 5-12c. - Resultant force on stump No. 1

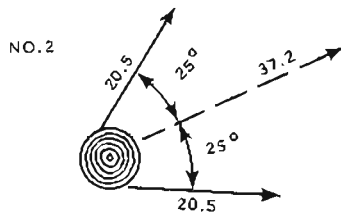

$$\text{RESULTANT FORCE} = 2(20.5) \cos 25^\circ = 37.2 \text{ KIPS}$$

Figure 5-12d. - Resultant force on stump No. 2

The actual loads on stumps 1 and 2 are 25.3 kips and 37.2 kips, respectively, which is much more than if the stumps had been rigged separately.

It is hoped that this information on the mechanics of skyline anchoring will greatly reduce future anchor failures and thereby improve the economics of cable yarding systems.

GUIDE FOR DESIGNING DEADMAN ANCHORS

1. Determine skyline tension (P) from skyline worksheets.
2. Select cable size (for Extra-Improved Plow Steel cable with safety factor of 3):

<u>Safe Working Load (P) (kips)</u>	<u>Cable Diameter (inches)</u>
13.7	5/8
19.6	3/4
26.5	7/8
34.5	1
43.3	1-1/8
53.3	1-1/4
64.0	1-3/8
76.0	1-1/2

3. Determine angle of pull on deadman (chord slope from horizontal).
4. From Chart No. 1 - Determine correction factor to be applied to the safe working load (P).

Corrected (P) = working load (P) x correction factor.

5. Using corrected (P) and known soil conditions at deadman location, determine log diameter and length from Chart No. 2A or 2B.
6. From Chart No. 3, determine necessary depth of burial.
7. Refer to "Suggestions for Deadman Installation" for burial recommendations.

SUGGESTIONS FOR DEADMAN INSTALLATION

1. Select deadman log from strong species such as firs, Ponderosa pine, larch, and lodgepole pine. Avoid cedar, spruce, and other species of low strength and density if possible.
2. Excavate trench at right angle to pull. Excavate wall as vertical as possible in the direction of pull.
3. Use a minimum of three bearing plates between the cable and log to prevent cutting. Refer to State Safety Codes for fastening requirements.
4. Excavate for the cable exit, to prevent bending in cable and vertical lifting of deadman.
5. Use good backfilling techniques as for culvert installation; i.e., layer placement and tamp with mechanical compactor.

Deadman Design Example No. 1

1. (P) from skyline worksheet = 30 kips.
Extra-Improved plow steel cable diameter required = 1-inch.
2. Burial is to be in spur road with downward pull (-θ) at 10%. Using Chart No. 1: Corrected (P) = 30 kips x 0.98 = 29 kips.
3. Soil in spur road is a "firm" gravel. From Chart No. 2A, select a 30-inch diameter log - 26 feet long.
4. From Chart No. 3, minimum trench depth = 2 x (30") = 5 feet. Locate trench at least 4 x (30") = 10 feet back from original ground line.

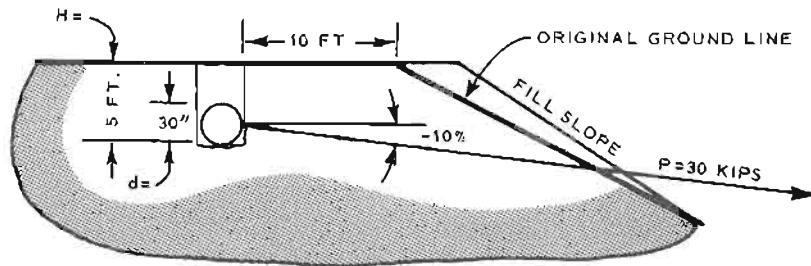

Figure 5-13

Deadman Design Example No. 2

1. (P) from skyline worksheet = 57 kips. Extra-Improved plow steel cable diameter required = 1-3/8-inch.
2. Pull is upward (+θ) at 25%. Ground slopes downward - 30%. Using Chart No. 1, Corrected (P) = 57 kips x 1.5 = 85 kips.
3. Soil is a "soft" to "firm" clay. From Chart No. 2B: Select a 48-inch diameter - 38 feet long.
4. There are no 48-inch diameter logs in the area, but there are 24-inch diameter logs available. How many 24-inch diameter deadmen are required? How long should they be? How should they be placed?
5. From Chart No. 2B select a 24-inch diameter log - 18 feet long, and for "soft" to "firm" clay find: Maximum corrected (P) = 20 kips.
6. Using Chart No. 1, if 25% is used as the approximate positive angle of pull (+θ), maximum working load (P) per deadman =

$$\frac{20 \text{ kips}}{\text{Correction factor for } +25\%} = \frac{20 \text{ kips}}{1.5} = 13 \text{ kips}$$

$$\text{Minimum number of } 24'' \times 18' \text{ deadmen required} = \frac{57 \text{ kips}}{13 \text{ kips}} = 4.4$$

Use four deadmen and resize length of 24-inch log:

$$\text{Corrected (P) per deadman} = \frac{57 \text{ kips}}{4} \times 1.5 = 21.5 \text{ kips}$$

From Chart No. 2B select a 24-inch diameter - 20 feet long.

7. Trial design using four 24-inch deadmen placed as shown in sketch. Since burial is on 30% sideslope, from Chart No. 3: Minimum trench depth = $3.2d = 3.2(24'') = \underline{6.4 \text{ feet}}$.

Minimum horizontal distance of undisturbed soil between deadman trenches = $4d = 4(24'') = \underline{8.0 \text{ feet}}$.

8. Distribute load as uniformly as possible to the four deadmen through the use of equalizer blocks.

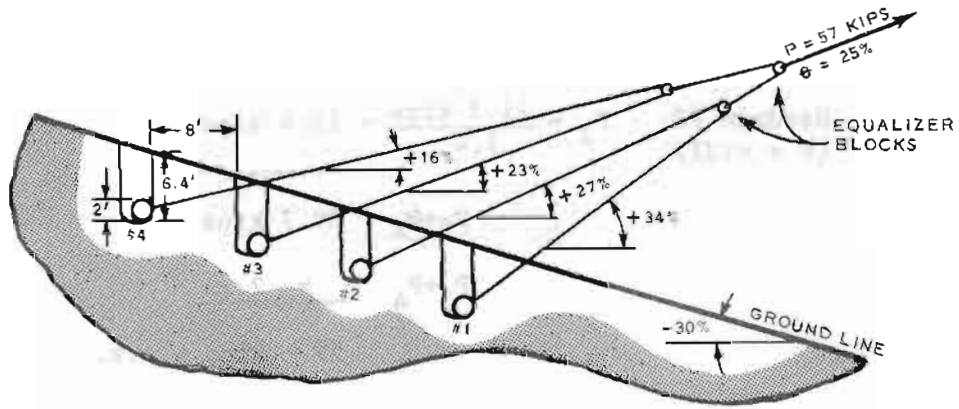

Figure 5-14

$$\text{Deadman \#1: } P_1 = \frac{21.5 \text{ kips}}{1.8} = 11.9 \text{ kips} \\ (\theta = +34\%)$$

$$\text{Deadman \#2: } P_2 = \frac{21.5 \text{ kips}}{1.5} = 14.3 \text{ kips} \\ (\theta = +27\%)$$

$$\text{Deadman \#3: } P_3 = \frac{21.5 \text{ kips}}{1.4} = 15.4 \text{ kips} \\ (\theta = +23\%)$$

$$\text{Deadman \#4: } P_4 = \frac{21.5 \text{ kips}}{1.2} = 17.9 \text{ kips} \\ (\theta = +16\%)$$

59 kips - o.k.

9. Test another possible design:

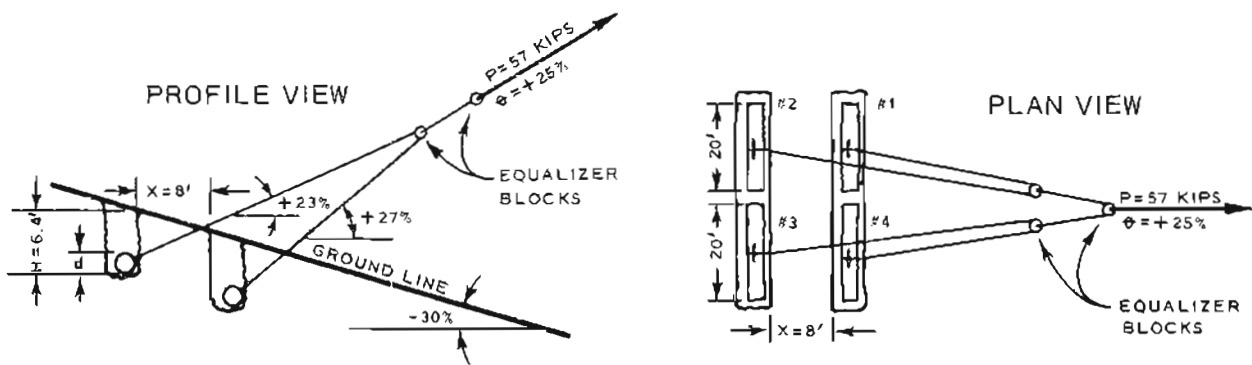

Figure 5-14A

Deadman #1: $P_1 = \frac{21.5 \text{ kips}}{1.5} = 14.3 \text{ kips}$
($\theta = +27\%$)

Deadman #2: $P_2 = \frac{21.5 \text{ kips}}{1.4} = 15.4 \text{ kips}$

$P_2 + P_2$ 29.7 kips

$P_3 + P_4$ $\frac{\quad \times 2}{\quad}$

59 kips - o.k.

CHART NO. 1 CORRECTION FOR PULL DIRECTION

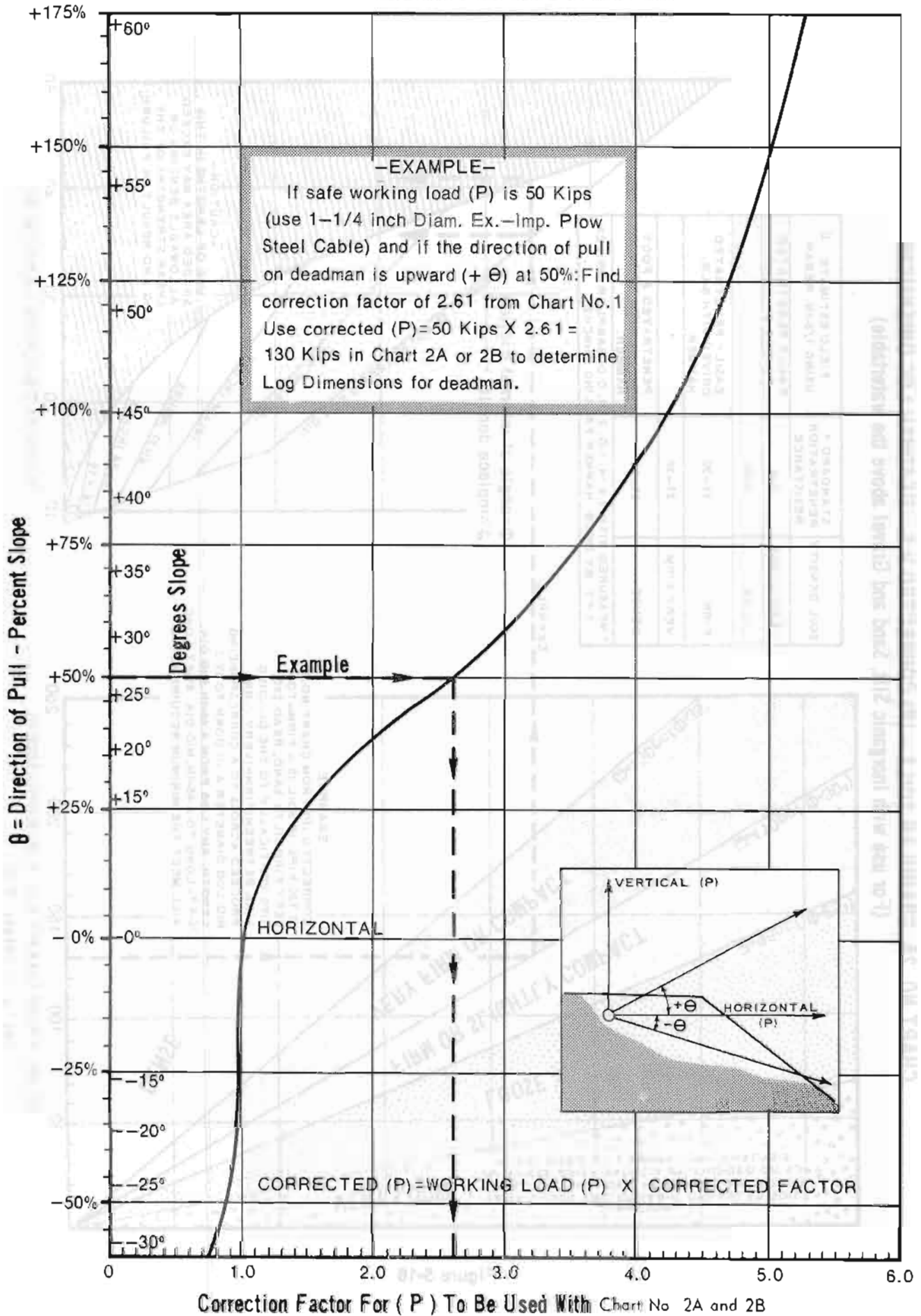

-EXAMPLE-
 If safe working load (P) is 50 Kips
 (use 1-1/4 inch Diam. Ex.-Imp. Plow
 Steel Cable) and if the direction of pull
 on deadman is upward (+ θ) at 50%: Find
 correction factor of 2.61 from Chart No.1
 Use corrected (P)=50 Kips X 2.61 =
 130 Kips in Chart 2A or 2B to determine
 Log Dimensions for deadman.

Figure 5-15

CHART NO. 2A GRANULAR SOILS - (P) CORRECTED V.S. DEADMAN LOG DIMENSIONS
 (For use with Inorganic Silt, Sand and Gravel above the watertable)

Figure 5-16

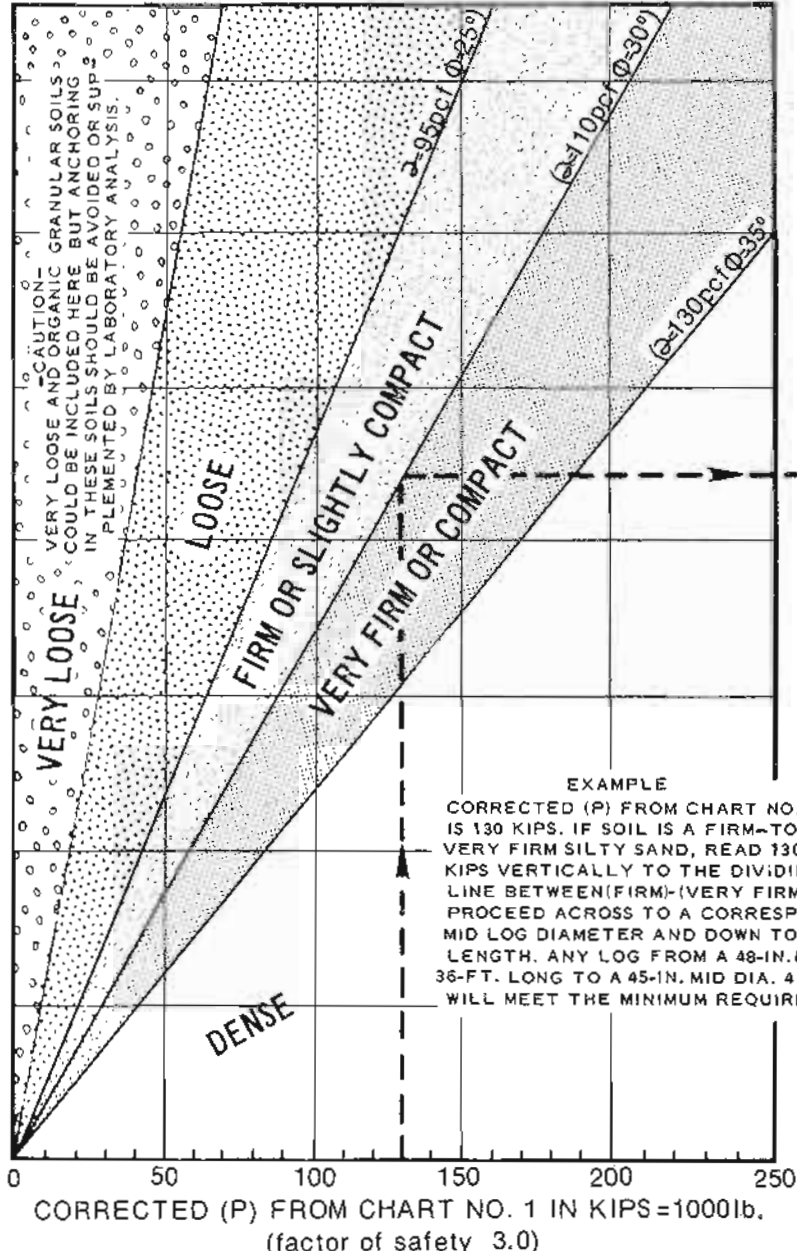

SOIL DENSITY	STANDARD * PENETRATION RESISTANCE	FIELD ESTIMATE \downarrow USING 1/2-IN. REBAR
VERY LOOSE	0-4	EASILY PENETRATED PUSHED BY HAND
LOOSE	5-10	
FIRM	11-20	EASILY PENETRATED DRIVEN WITH 5-LB. HAMMER
VERY FIRM	21-30	
DENSE	31-50	PENETRATED A FOOT DRIVEN WITH 5-LB. HAMMER.

* MEASURED WITH 1.4 IN. I.D. 2 IN. O.D. SAMPLER DRIVEN 1 FT. BY 140LB. HAMMER FALLING 30 INCHES.

EXAMPLE
 CORRECTED (P) FROM CHART NO.1 IS 130 KIIPS. IF SOIL IS A FIRM-TO-VERY FIRM SILTY SAND, READ 130 KIIPS VERTICALLY TO THE DIVIDING LINE BETWEEN (FIRM)-(VERY FIRM) PROCEED ACROSS TO A CORRESPONDING MID LOG DIAMETER AND DOWN TO IT'S LENGTH. ANY LOG FROM A 48-IN. MID DIA. 36-FT. LONG TO A 45-IN. MID DIA. 41-FT. LONG WILL MEET THE MINIMUM REQUIREMENTS.

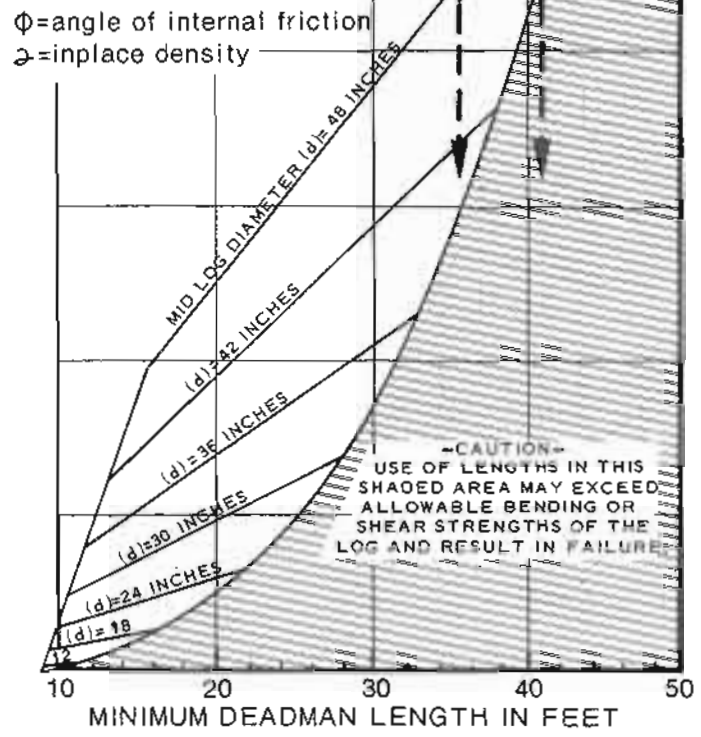
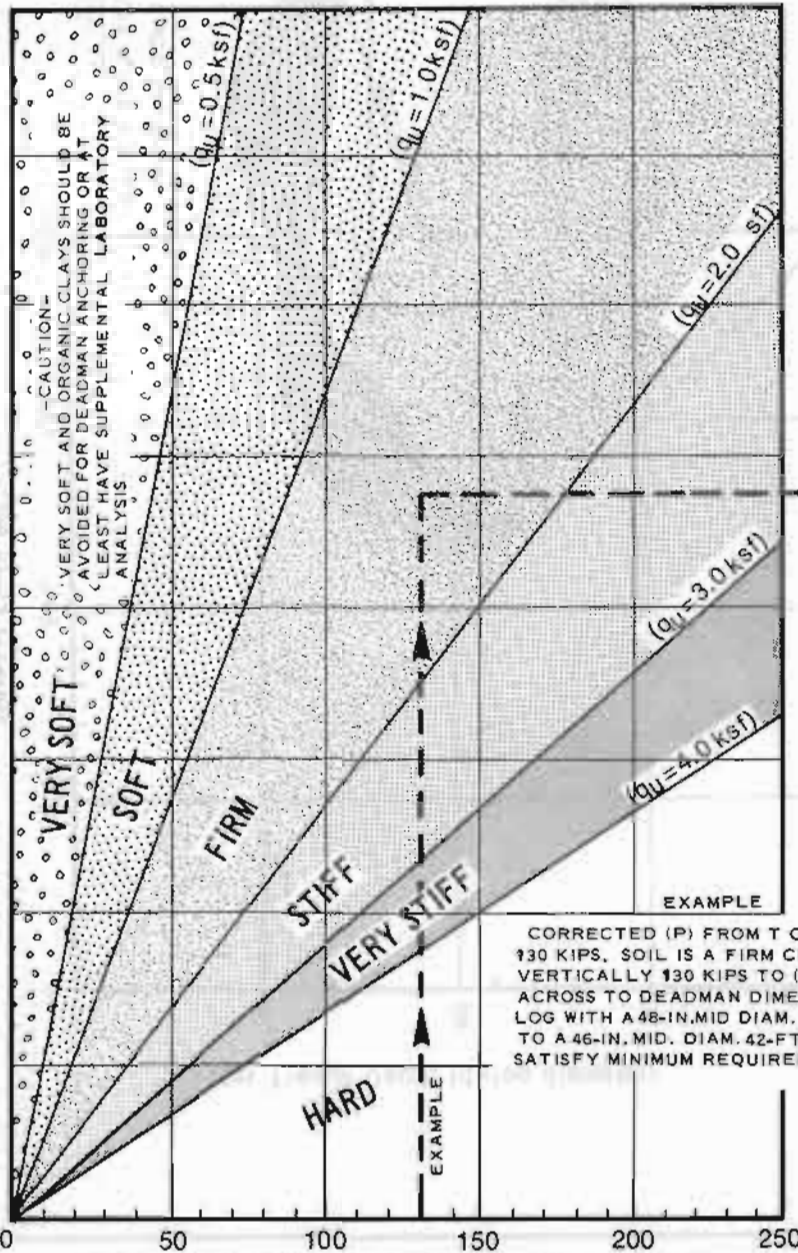

CHART NO. 2B CLAYEY SOILS (P) CORRECTED V.S. DEADMAN LOG DIMENSIONS

(For use with Inorganic Clays above the watertable)



SOIL STRENGTH	STANDARD * PENETRATION RESISTANCE	FIELD ESTIMATE ¹⁾
VERY SOFT	0-1	SQUEEZES BETWEEN FINGERS WHEN FIST IS CLOSED.
SOFT	2-4	EASILY MOLDED BY FINGERS.
FIRM	5-8	MOLDED BY STRONG PRESSURE OF FINGERS
STIFF	9-15	DENTED BY STRONG PRESSURE OF FINGERS.
VERY STIFF	15-30	DENTED ONLY SLIGHTLY, BY STRONG FINGER PRESSURE.
HARD	OVER 30	DENTED ONLY SLIGHTLY BY PENCIL POINT.

* MEASURED WITH 1.4 IN. I.D. 2 IN. O.D. SAMPLER DRIVEN 1 FT. BY 140LB. HAMMER FALLING 30 IN.

EXAMPLE

CORRECTED (P) FROM T CHART NO. 1 130 KIPS. SOIL IS A FIRM CLAY. READ VERTICALLY 130 KIPS TO (FIRM) THEN ACROSS TO DEADMAN DIMENSIONS. ANY LOG WITH A 48-IN. MID DIAM. 39-FT. LONG TO TO A 46-IN. MID. DIAM. 42-FT LONG WILL SATISFY MINIMUM REQUIREMENTS.

(q_u = unconfined compressive strength)

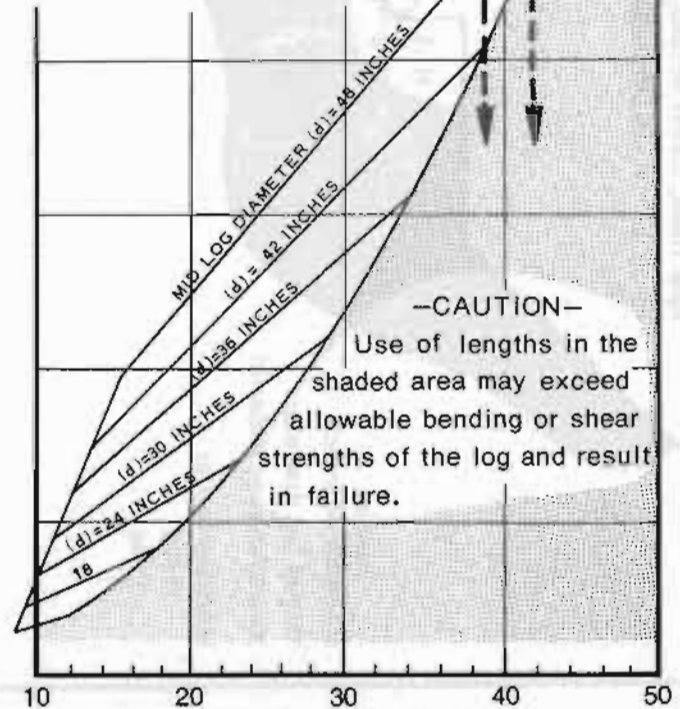

Corrected (P) From Chart No. 1 in Kips=1000lbs.
(factor of safety 3.0)

Minimum Deadman Length in Feet

Figure 5-17

DEADMAN BURIAL

Spur Road, Level Ground, or Ground Sloping Upward
in Direction of Pull

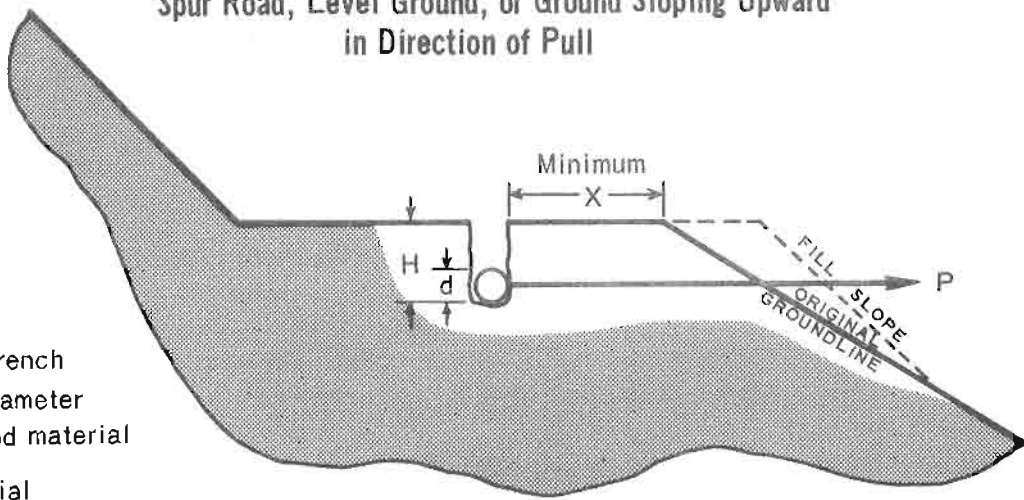

LEGEND
 H=depth of trench
 d=mid log diameter
 X=undisturbed material

Minimum Burial
 $H=2d$
 $X=4d$

CHART NO. 3 Ground Sloping Downward in Pull Direction

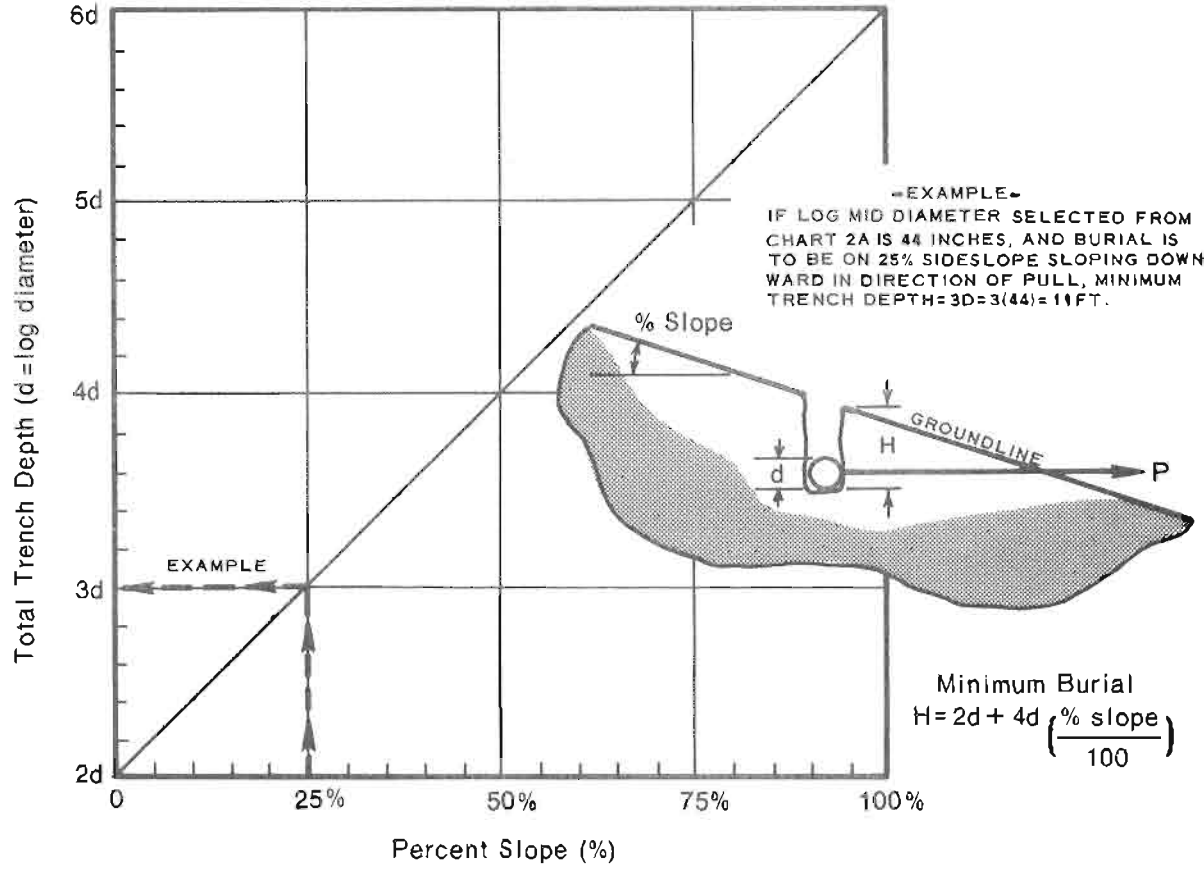

Figure 5-18

CHAPTER 6 MECHANICS OF GUYLINES

Guylines are wire ropes used to hold spar trees or towers against an over-turning force. This force may be imposed by stresses in the mainline, a skyline or haulback line, or by the wind. Force exerted by wind depends upon diameter, height and shape of the tower. Wind force will not be considered here because its magnitude is small, compared to forces exerted by the skyline, mainline, or haulback line.

Factors contributing to the effectiveness of guys are:

1. Number of guys.
2. Spacing of guys.
3. Direction of applied force.
4. Angles of guys with the horizontal.

Required guy numbers depend upon the type of spar and its height. Most portable steel spars used in highlead logging require six guys. Heavy-duty skyline towers require seven or eight guys. The state safety codes require spars over a specified height to be equipped with a certain number of guys. For example, the Oregon State Safety Code requires that vertical portable steel spars, 55 feet or more in height from the base or trunion, be equipped with at least six guys, if the guys meet the strength requirements. Leaning-type portable steel spars, 55 feet or more long, require at least three back guys. Leaning spars of less than 55 feet require at least two back guys arranged to form an angle between 70° and 90° with each other and opposite to the direction of stress.

The code further states that boom-type machines used for yarding need not be guyed if they are specifically designed for use without guys.

When compressive stresses are placed on the top of a spar tree, the spar will tend to deflect laterally at the mid-point. The code requires at least three buckle guys on wooden spar trees over 110 feet high.

Guy spacing around the tower depends primarily upon where the anchors can be located. The guys should be spaced uniformly, whenever possible, to equalize the stresses.

The direction of the force applied to the top of the tower by loading the skyline or machine is very important. The tower should be erected and guyed to resist the most critical situation. This occurs when the direction of the applied force results in maximum stresses in the fewest number of guys.

The following table lists guy factors for various numbers of guys and positions of applied force:

<u>Number of guys equally spaced</u>	<u>Critical position of applied force</u>	<u>Guy Factor</u>
3	30° from any guy	.866
4	Opposite any guy	1.000
5	18° from any guy	1.539
6	30° from any guy	1.732
7	12°51' from any guy	2.190
8	Opposite any guy	2.414
9	10° from any guy	2.836
10	18° from any guy	3.078

These factors apply to the horizontal pull at the same elevation of the guy-line circle. The horizontal component of the applied force is found and divided by the load factor. The result is the maximum horizontal pull in any one guy.

EXAMPLES

Given: A tower with six equally spaced guys supports a 1½-inch diameter skyline (figure 6-1). The skyline enters the tower at a vertical angle of 20° from the horizontal. It makes a horizontal angle of 30° with the nearest guy. Assume that the guys and skyline are on the same horizontal plane. The guy makes an angle of 40° with the horizontal.

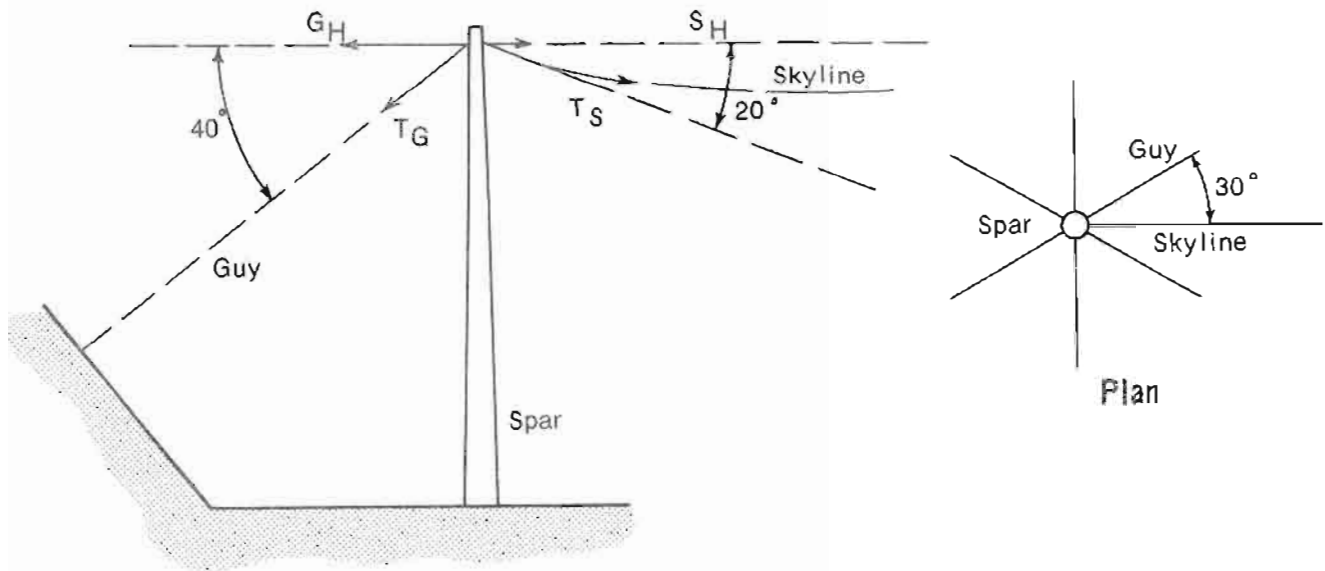

Profile Figure 6-1

Find: The tension in the most critical guy.

Solution: Let S_H = horizontal force due to the tension in the skyline.

G_H = horizontal force due to the tension in the guy.

T_G = Tension in guy.

T_S = Tension in skyline.

The maximum stress in the skyline is equal to its breaking strength. For 1½-inch diameter Extra Improved Plow Steel the breaking strength is 228,000 lbs.

Therefore: $S_H = 228,000 (\cos. 20^\circ) = 228,000 (.93969) = 214,249.32$ lbs.

The guy factor for six guys with the force applied at 30° from any guy is 1.732.

Therefore: $G_H = 214,249.32 \div 1.732 = 123,700.53$

The stress in the guy will be:

$$T_S = \frac{G_H}{\cos 40^\circ} = \frac{123,700.53}{.766} = 161,488.94$$

Therefore 1-3/8-inch diameter guys would be needed.

The following table may be used as a guide in determining the applied force that can be resisted by all guys.

<u>Number of guys equally spaced</u>	<u>Applied Force is</u>	<u>G_H will resist a force, S_H equal to</u>
3	Opposite one guy	100% of the horizontal force of one guy
4	Halfway between 2 guys	140% of the horizontal force of one guy
5	Opposite one guy or halfway between 2 guys	160% of the horizontal force of one guy
6	Opposite one guy	200% of the horizontal force of one guy
7	Opposite one guy or halfway between 2 guys	225% of the horizontal force of one guy
8	Halfway between 2 guys	260% of the horizontal force of one guy
9	Opposite one guy or halfway between 2 guys	290% of the horizontal force of one guy
10	Opposite one guy	223% of the horizontal force of one guy

In the above example, if the skyline were rigged opposite one guy, all six guys will resist an applied horizontal force S_H , equal to 200% of the horizontal force G_H , of one guy. If 1-1/8-inch diameter guys are used, the horizontal component of a guy rigged at 40° with the horizontal is:

$$G_H = 130,000 \times .766 = 99,580 \text{ lbs.}$$

Then: $S_H = 200\% \times 99,580 = 199,160 \text{ lbs.}$

Assuming the skyline enters the tower of an angle of 20° with the horizontal, the tension in the skyline will be:

$$T_S = \frac{199,160}{\cos. 20^\circ} = 211,942 \text{ lbs.}$$

Therefore, assuming the six guys are equally spaced and that each makes an angle of 40° with the horizontal, they can resist a tension in the skyline of 211,942 lbs. This would be equivalent to a 1-3/8-inch diameter skyline. Actually, the mainline is also exerting a force on the tower in approximately the same direction as the skyline. Therefore, in the above example, the 211,942 lbs. is equivalent to a 1-1/8-inch diameter skyline and a 7/8-inch diameter mainline. This assumes that both lines are stressed to their breaking strength at the same time.

The angle that the guy makes with the horizontal is referred to as the effective guy line. The following table is a guide to determine the effectiveness of guys:

<u>Effective Angle Degrees</u>	<u>Effectiveness of Guys</u>
60-45	50%-75%
45-30	75%-85%
30-10	85%-95%

The percent effectiveness in the above table is an approximation of the cosine of the angle.

For example, if a 1-1/8-inch diameter guy makes an angle of 40° with the horizontal, the horizontal component G_H will be:

$$G_H = 130,000 \times .766 = 99,580 \text{ lbs.}$$

or we can say that the guy is only 76.6% effective.

A standing skyline may be rigged with the skyline passing across the top of the tower through a banjo fairlead. The loads imposed on the tower with this type of rigging may be different in magnitude and direction from those imposed by a highlead or a live skyline system. Consider the rigging situation as presented in figure 6-2. The tension in the skyline will be the same on both sides of the fairlead. However, if the skyline angles with the horizontal, entering and leaving the tower, are not equal; the horizontal components of tension will not be equal. The tower must be guyed to compensate for this difference in tension.

It can readily be seen that if the horizontal component on the back side of the tower is greater, more load will be imposed on the front guys than on the back guys.

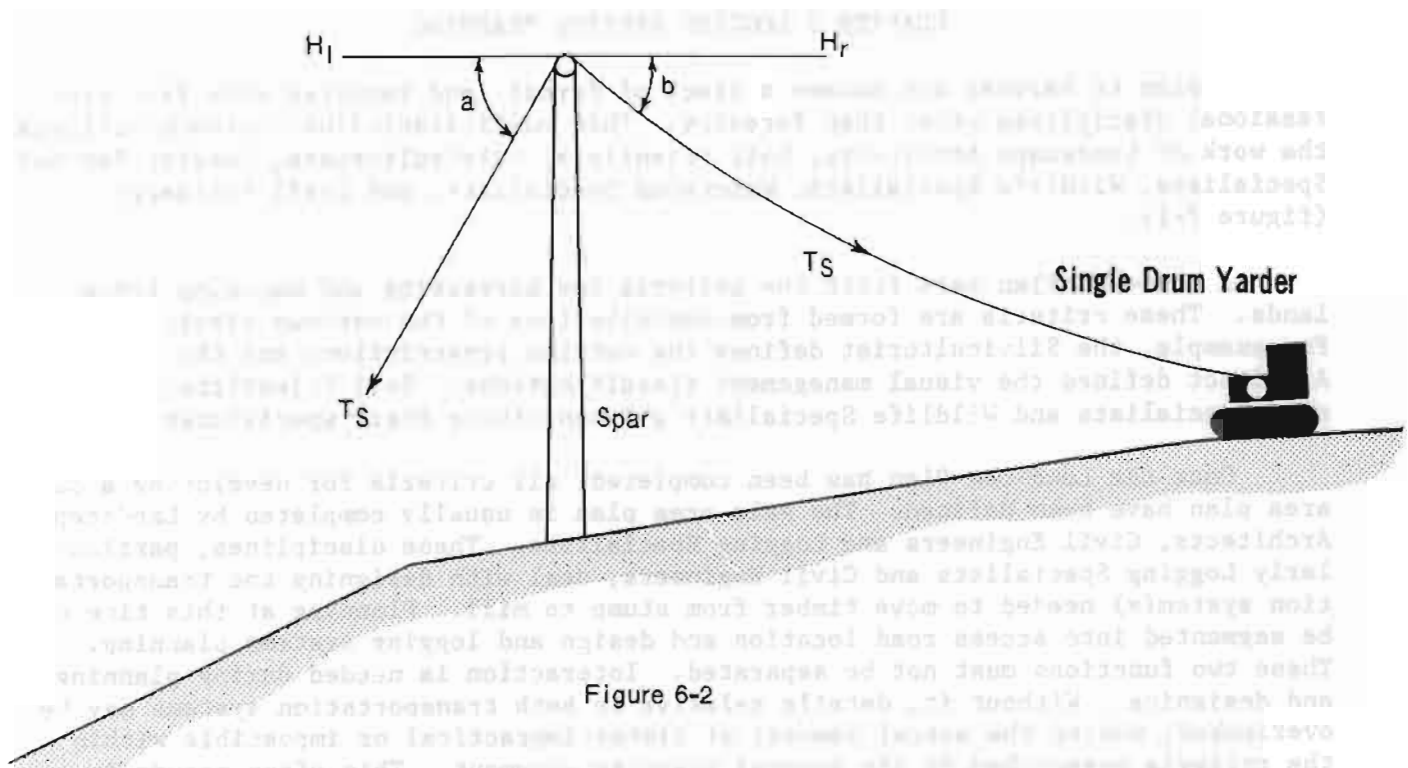

Figure 6-2

EXAMPLE

Given: A $1\frac{1}{2}$ -inch diameter skyline passes across a tower as illustrated above.

$$\text{angle } a = 60^\circ$$

$$\text{angle } b = 40^\circ$$

$$T_s = 228,000 \text{ lbs.}$$

Find: The horizontal forces acting on the tower

$$\text{Solution: } H_L = 228000 \cos. 60^\circ = 228000 (.5) = 114,000 \text{ lbs.}$$

$$H_R = 228000 \cos. 40^\circ = 228000 (.766) = 174,648 \text{ lbs.}$$

From this example it can be seen that the resultant horizontal force on the tower is acting in a direction to push the tower over backwards. Therefore, the front guys will be resisting this force. If the skyline were rigged with angle (a) greater than angle (b), then the back guys would have to resist the resultant horizontal force.

Each setting should be investigated to insure that the guys will be effective. It is possible to rig a tower so that the guys are adding to the forces acting on the tower instead of resisting them.

CHAPTER 7 LOGGING SYSTEMS PLANNING

A plan to harvest and manage a tract of forest land requires work from professional disciplines other than forestry. This multi-discipline approach utilizes the work of Landscape Architects, Soil Scientists, Silviculturists, Logging Systems Specialists, Wildlife Specialists, Watershed Specialists, and Civil Engineers (figure 7-1).

A Land-Use Plan sets forth the criteria for harvesting and managing forest lands. These criteria are formed from contributions of the various disciplines. For example, the Silviculturist defines the cutting prescriptions and the Landscape Architect defines the visual management classifications. Soil Scientists, Watershed Specialists and Wildlife Specialists all contribute their specializations.

Once the Land-Use Plan has been completed, all criteria for developing a sale area plan have been defined. The sale-area plan is usually completed by Landscape Architects, Civil Engineers and Logging Specialists. These disciplines, particularly Logging Specialists and Civil Engineers, deal with designing the transportation system(s) needed to move timber from stump to mill. Planning at this time can be segmented into access road location and design and logging systems planning. These two functions must not be separated. Interaction is needed during planning and designing. Without it, details relative to both transportation systems may be overlooked, making the actual removal of timber impractical or impossible within the criteria prescribed in the general planning document. This often occurs in areas of access road and landing location, particularly relating to highlead and skyline systems.

PAPER PLANNING

The first step in developing a timber harvest operation is "Paper Planning" (figure 7-2). A logging plan compatible with the various land management objectives must be made and considered during layout, to insure that all phases of layout conform. The plan must be reasonable and logical and its full impact must be visualized. The plan will be used by the appraiser in working up costs, be reflected in appropriate contract clauses to insure that land management objectives are achieved, serve as a reference for the timber sale administrator, and be available for preparation of future rate redeterminations.

The objective of the paper plan is to:

1. Provide management with a preview of planned harvest systems and silvicultural treatments proposed to meet land management objectives.
2. Identify problems for on-site review.
3. Reduce to a manageable number the alternatives considered for on-site work.
4. Identify the least costly solution which meets land management criteria.
5. Provide a blueprint or plan for field layout.

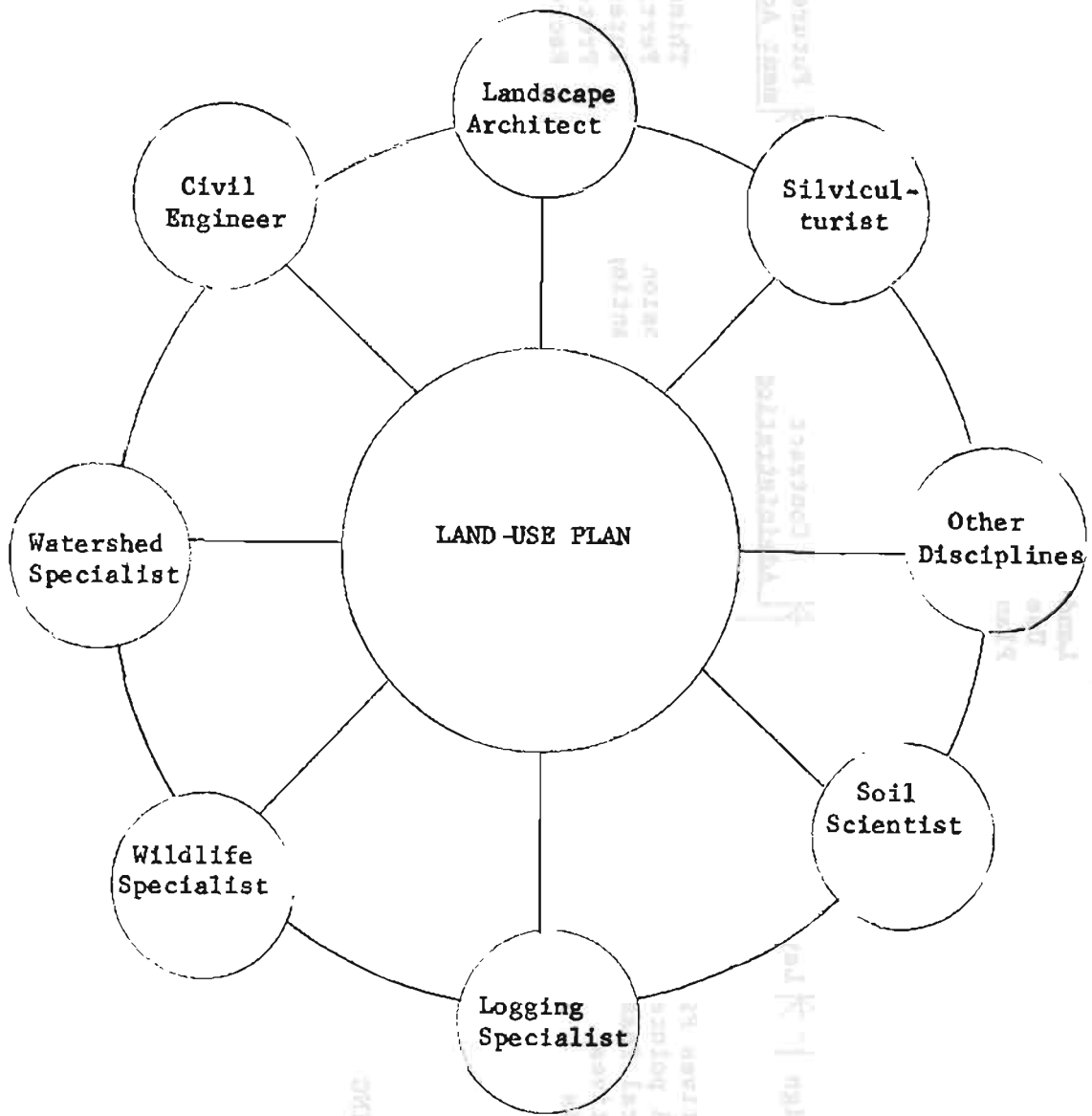

Fig. 7-1 BASIN PLANNING

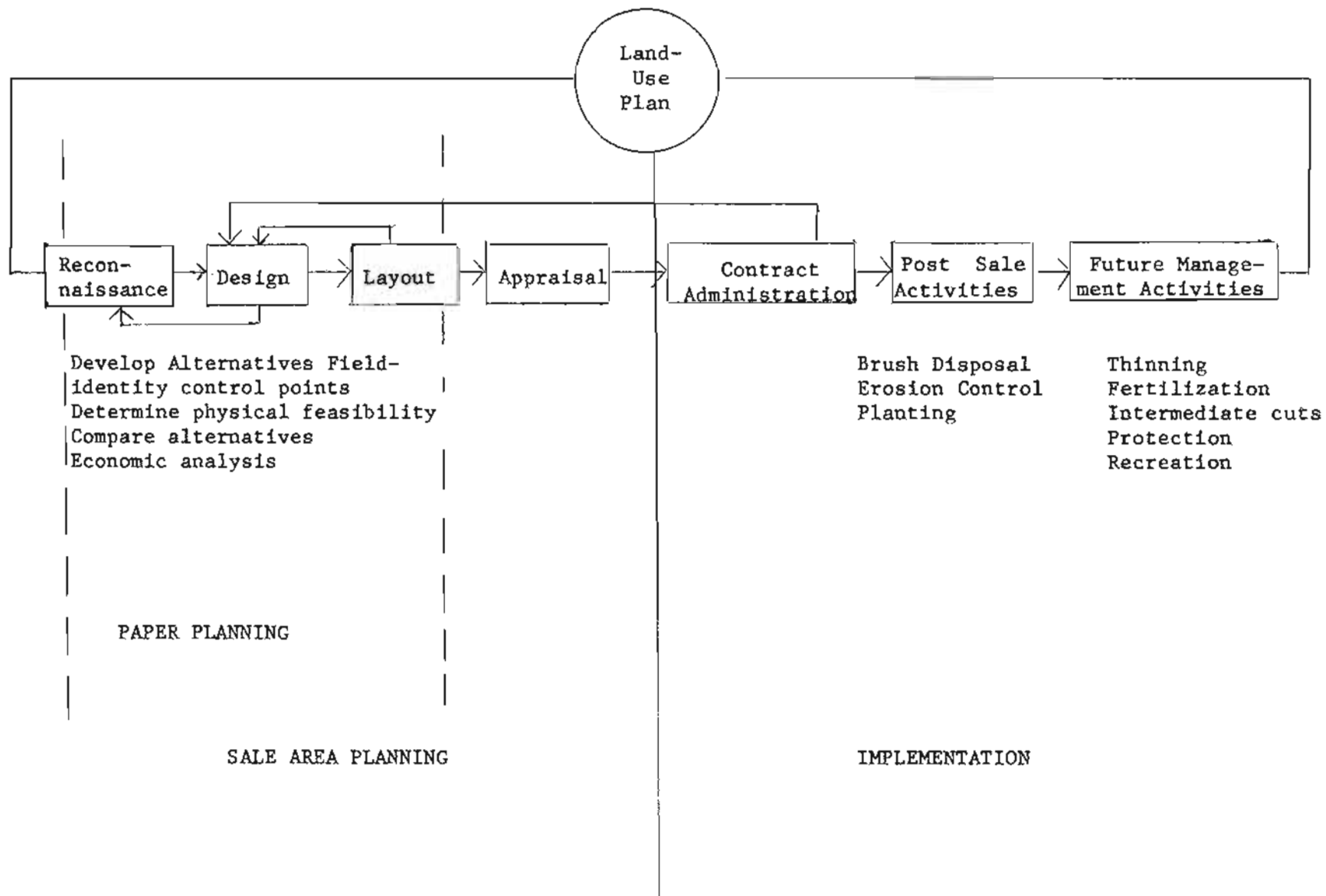

Fig. 7-2 TIMBER HARVEST PLANNING

Paper planning involves both field and office work. In general, it can be divided into two stages--reconnaissance and design.

RECONNAISSANCE

In the reconnaissance stage, maps and aerial photos should be studied to become familiar with the area. The field reconnaissance should provide information not observed from maps, aerial photos or other resource documents. In the design stage, physical feasibility is determined, economic comparisons are made, haul routes are determined, and in general, a plan is prepared that can be fitted to the ground and also meet the land management constraints. At any time during the design stage, more information may be needed and the planning process will move into a higher order reconnaissance stage (See fig. 7-2).

It is not possible to list or evaluate in a short chapter, all of the possible planning variables from land management constraints, or the variables that must be considered in the evaluation of a primary or secondary road system. The emphasis here will be on evaluating the trinary road system: i.e., the road system actually used in the harvest operation.

The first step in plan development is to review for adequacy, existing aerial photos and maps of the area under design. Without quality photos and accurate topographic maps of the proper scale, nothing can be done in the way of designing satisfactory timber harvest operations.

If the aerial photos and topography maps of the area are satisfactory, the next step is collecting data and information relative to the management of the area such as: (1) Multiple Use map. (2) Functional objectives and/or plans. (3) Resource data such as soil and timber-type maps.

The more information relative to the management of the area that can be used, the better the alternatives listed in the Land-Use Plan will fit the management objectives of the area. There is a direct relationship between the quality of the paper plan and the planner's ability and knowledge of the site under design.

Numerous methods are available for storage and display of the collected data. Perhaps the simplest system is overlays. The topographic map is used as a base map showing all improvements and land status. All other data is shown on overlays to the topography map.

DESIGN

ROADS

Once the planner has gathered sufficient data and has a good feel for the area, the next step is to develop a preliminary road system.

In the development of preliminary road systems, first priority should be given to existing roads. The existing road system should be reviewed for adequacy of location, standard, and condition. Any problems identified must be considered in the design of the timber harvest operation.

In many cases, roads may be possible only to specific points or through certain zones because of slope stability, erosion, Multiple Use considerations, etc.

In this situation, the first priority is to determine the areas where no timber harvest is appropriate.

The next step is to develop the road system with the highest probability of success, and from this road system, review the systems available to log the timber available for harvest. The logging system used must be a reflection of both access and management constraints.

LOGGING SYSTEM

The logging equipment and system used is dictated by:

1. Multiple Use considerations and management objectives.
2. Slope.
3. Timber size.
4. Silvicultural treatment.
5. Direction of yarding uphill or downhill.
6. Post-sale cultural activities.
7. Special yarding problems.

A critical review of the above will generally indicate one or two possible logging systems and the yarding distances that are appropriate.

It must be remembered that it is not possible to separate the hauling and the logging systems. They are both part of the log transport system. The layout of the road system will require the planner to visualize the logging system to be used.

The design of any area will generally incorporate the use of more than one logging system. It is the combination of the logging systems that influences alternate locations.

Yarding distance is then used as one basis for determining the location of the primary road system. It should be remembered that if 1000 feet is used as the maximum allowable distance between roads, then the average distance will be less than 1000 feet.

Once the preliminary haul routes have been identified, the next step is to identify yarder positions. It is normally the intent to develop the maximum timber with a minimum number of yarder positions. It should be recognized that in paper planning all of the settings necessary to log the area will not be identified.

Yarder position depends upon the planner's ability to identify yarding and rigging problems such as:

1. Sidehill yarding - Usually it is not possible or desirable to completely eliminate sidehill yarding. It is possible to identify the yarding problems and site disturbance potential associated with sidehill yarding.

2. Blind lead - At the "paper plan" level, the blind leads should be identified and must be avoided. Blind leads contribute a major part of the soil damage in highlead yarding.
3. Anchors - It is generally sufficient to note if there is timber for anchors, both at the yarder and at the tailhold. If no timber exists at one or both areas, the area should be reviewed for possible deadman anchors or rockbolts and for the impact of the installations.
4. Deflection - It is generally sufficient to run one profile per setting, that with the minimum deflection.
5. Guy angles - It is difficult to evaluate guy angles at the paper-plan level. Generally, it is sufficient to keep landings away from the top of sharp ridges.
6. Downhill yarding - For running skylines in clearcuts, this is no problem. For most other systems, the objective generally is to minimize downhill yarding, unless design specifically calls for downhill yarding. Then systems requirements must be accurately defined.

Silvicultural treatment must be considered in yarder positioning. Generally, selective logging requires cableways at right angles to the slope. Land management constraints usually affect yarder positions by limiting size and locations of landings.

At the "Paper Plan" level, it is impossible to determine the total impact of landing sizes and locations. It is possible, however, to predict critical settings --from general knowledge of side slopes, landing location and harvesting equipment. As tentative yarder positions are located, setting boundaries can be drawn.

Yarding distance must be slope distance, not horizontal or map distance. The setting boundaries are governed by yarding distances and identified yarding problems. At this point, changes generally will be required in the haul system to overcome yarding problems or changes in the logging system will be necessary to overcome problems with the hauling system.

OTHER CONSIDERATIONS

More than one harvest plan should be developed to provide a decision basis. Generally, the plans will be similar, because of similar restraints, and will be variations of a common theme.

The logging and transportation planning process should include the following steps:

1. Delineate area to be planned.
2. Identify resource management objectives for the area.
3. Delineate areas within the plan area to be served by

the road system (i.e., commercial forest land, appropriate marginal area, etc.). This automatically delineates areas not to be roaded.

4. Delineate areas where roads cannot be built because of other land management constraints.
5. Identification of control points, such as: Tie roads to adjacent plan areas, topographic features (saddles, creek crossings, etc.), and areas where roads will be unacceptable (critical soils, multiple use conflicts, etc.).
6. Determine which logging systems are acceptable for managing the timber resource. This includes considering the management of future stands, (will they be intensively managed?), the limitations of the various logging systems and logging restrictions needed to prevent unacceptable environmental impact.
7. Determine the acceptable road spacing and the geometric road design criteria. Coordinate this with ground conditions, acceptable logging systems equipment size and other resource management directions.
8. Study aerial photos and make necessary ground reconnaissance to verify practicality of road and landing location alternatives and eliminate unacceptable alternatives.
9. Make economic analysis for the remaining alternative transportation and logging plans.
10. Determine the most acceptable transportation and logging plan alternative based on resource management objectives and economics.

Logging and transportation planning necessitates numerous decisions. The most difficult will probably be related to management objectives for resources other than timber. Following are a few items for decision when timber management is the principal consideration:

1. Fewer roads reduce the impact on soils and watershed, but increase yarding distance and yarding cost. This may be desirable for future management.
2. Increasing yarding distance limits the logging systems and logging equipment that can be used on an area. Generally it requires larger equipment which needs wider roads.
3. Increasing yarding distance beyond 1000 feet (depending on deflection) and something less downhill may limit opportunity for intensive future timber management.
4. It may be preferable to have a high yarding cost rather

than to build additional road.

5. Elimination of a road may result in isolating a timber stand by making it economically inaccessible.

The logging and transportation plan must be compatible with the ultimate development of the entire drainage. If an area is highgraded with the first sale, it may be uneconomical and/or highly undesirable to harvest the remaining timber.

Sale layout may be considered as part of the paper planning process. Quite often, layout is done in conjunction with the planning, through field verification procedures. If different personnel are doing the layout, feedback to the designers is necessary. This insures that any alterations to the plan will be done under the land management constraints.

After the paper plan is completed, all of the information needed to appraise harvesting costs should be available. Preliminary cost analyses are made throughout the paper planning stage. The appraisal, however, is the final economic determination which establishes a cost for all items required as part of the contract and in turn, sets a minimum acceptable value for the timber.

Contract administration assures that the timber harvest is carried out in the manner planned. Again, during this stage, feedback to the designers is necessary. Should a problem occur requiring modification of the plan to facilitate harvesting, it must be evaluated in the same manner as the initial plan to assure that it meets the criteria set forth by the Land-Use Plan.

The sale area plan has not been carried out fully until all post-sale activities have been completed. These may include brush disposal, erosion control, restoration work and planting.

A plan, to be useful, must satisfy a need. However, designing a plan for just the present is not usually sufficient. With few exceptions, the plan must continue to meet a need for a specified period in order to justify the investment of time, money and effort. A plan must be dynamic to cover management activities in the harvest area over the next rotation period. Thinning, fertilization, and intermediate cuts, may be carried out as part of the initial timber harvest plan which is an extension of the Land-Use Plan.

CHAPTER 8 SALE LAYOUT CONSIDERATIONS BY SILVICULTURAL CUTTING PRESCRIPTIONS

Cable yarding systems range from small homemade wooden-boom jammers to large complex skyline yarders and towers costing more than \$250,000. Many of these systems work well under a variety of conditions and silvicultural prescriptions, while others work only in specific situations.

It is up to the Logging Specialist to choose the best harvest system to fit the topography, silvicultural prescription, and other resource objectives--keeping in mind the harvest requirements for the entire forest.

This chapter provides the Logging Specialist with some of the basic information and layout criteria for the various systems. Material is organized under the headings of Clearcut, Overstory Removal and Thinnings because of the specific equipment requirements for these different silvicultural practices.

CLEARCUTTING

Highlead (Fig. 8-1)

Highlead has been the most widely used cable yarding system in the United States. Highlead equipment comes in a variety of sizes, from the wooden-boom jammer to the modern steel tower and yarder. The system consists of a two-drum yarder with an auxiliary drum used for rigging, and a spar or tower. The tower is usually mounted on a carrier such as a low-boy trailer, or a self-propelled unit. The self-propelled unit may be mounted on rubber tires or tracks.

Logs are yarded to the landing by mainline and the haulback line pulls the mainline and the rigging back out to the brush.

The term "highlead" refers to the location of the mainline block elevated above the ground by the spar. The high block provides the vertical lift which allows the logs to override obstacles. Conversely, in the "groundlead" system, the logs either force their way through obstacles or are forced around them.

In highleading, the vertical lifting force depends upon:

1. The height of the mainline block. The higher the block, the greater the lift. Table 8-1 shows the relative yarding distance by spar height.
2. The profile of the ground from the spar to the log. The more concave the slope, the greater the lift.
3. The distance of the log from the spar. The greater the distance, the smaller the lifting force.
4. The braking capacity of the haulback drum which provides the necessary lifting force to tightline a turn. This may also be accomplished by interlocking drums.

HIGHLEAD

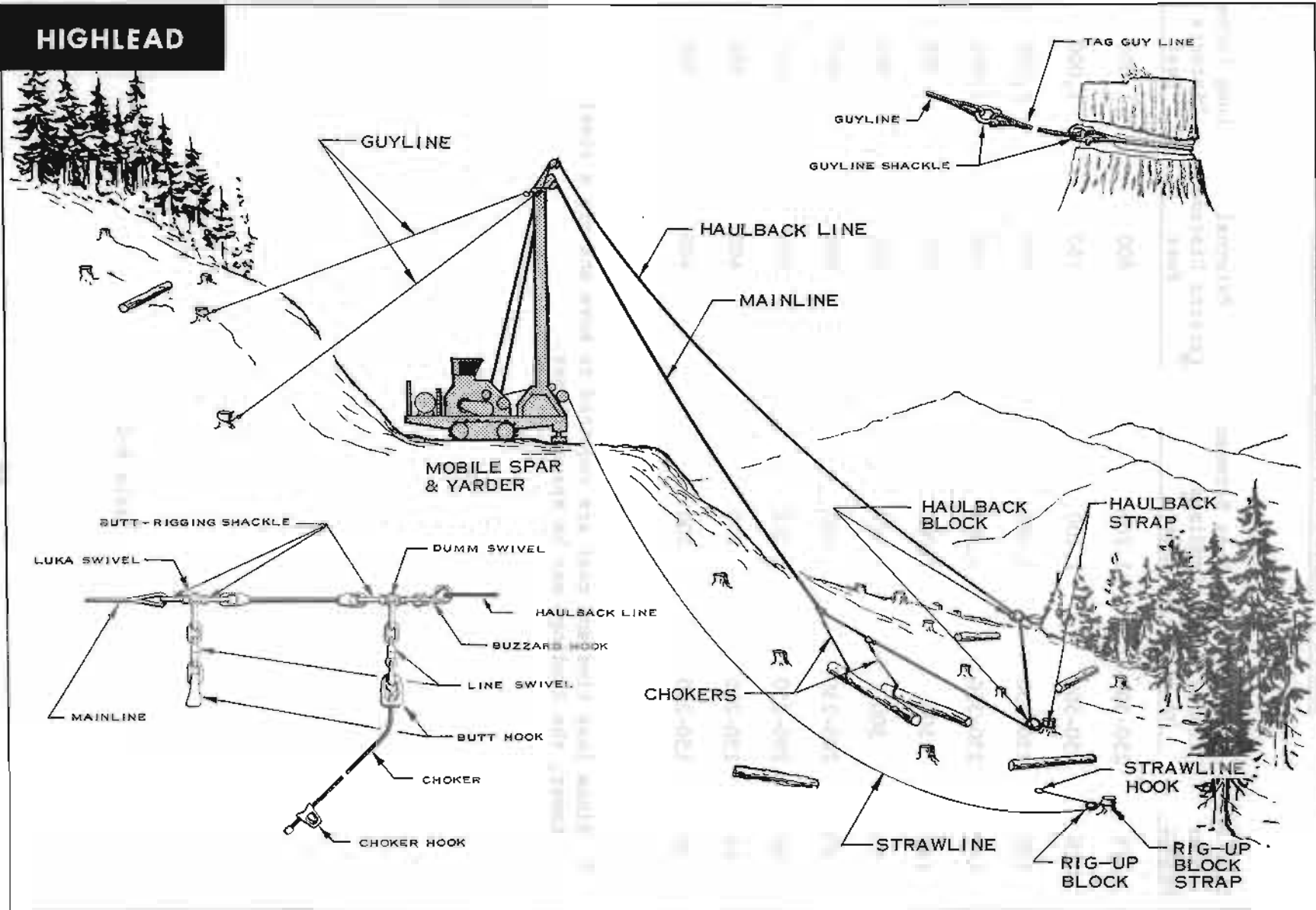

FIGURE 8-1

RELATIVE YARDING DISTANCE BY SPAR HEIGHT

<u>Spar or Tower Height</u>	<u>Yarded hp</u>	<u>Spacings Between Landings Feet</u>	<u>External Yarding Distance Feet</u>	<u>Long Corner Distance Feet</u>
175	250-500	1,200	800	1,000
150	250-500	1,100	750	1,000
120	250-350	1,000	700	1,000
110	250-350	1,000*	700	1,000
100	300	1,000	700	900
90	300	900	700	900
70	200-250	800	600	800
50	200-250	300	500	600
42	150-200	200	400	500
30	150-200	200	400	500

* Since less time and cost are required to move and rig a steel tower, the landings may be spaced closer.

Table 8-1

HANG - UPS

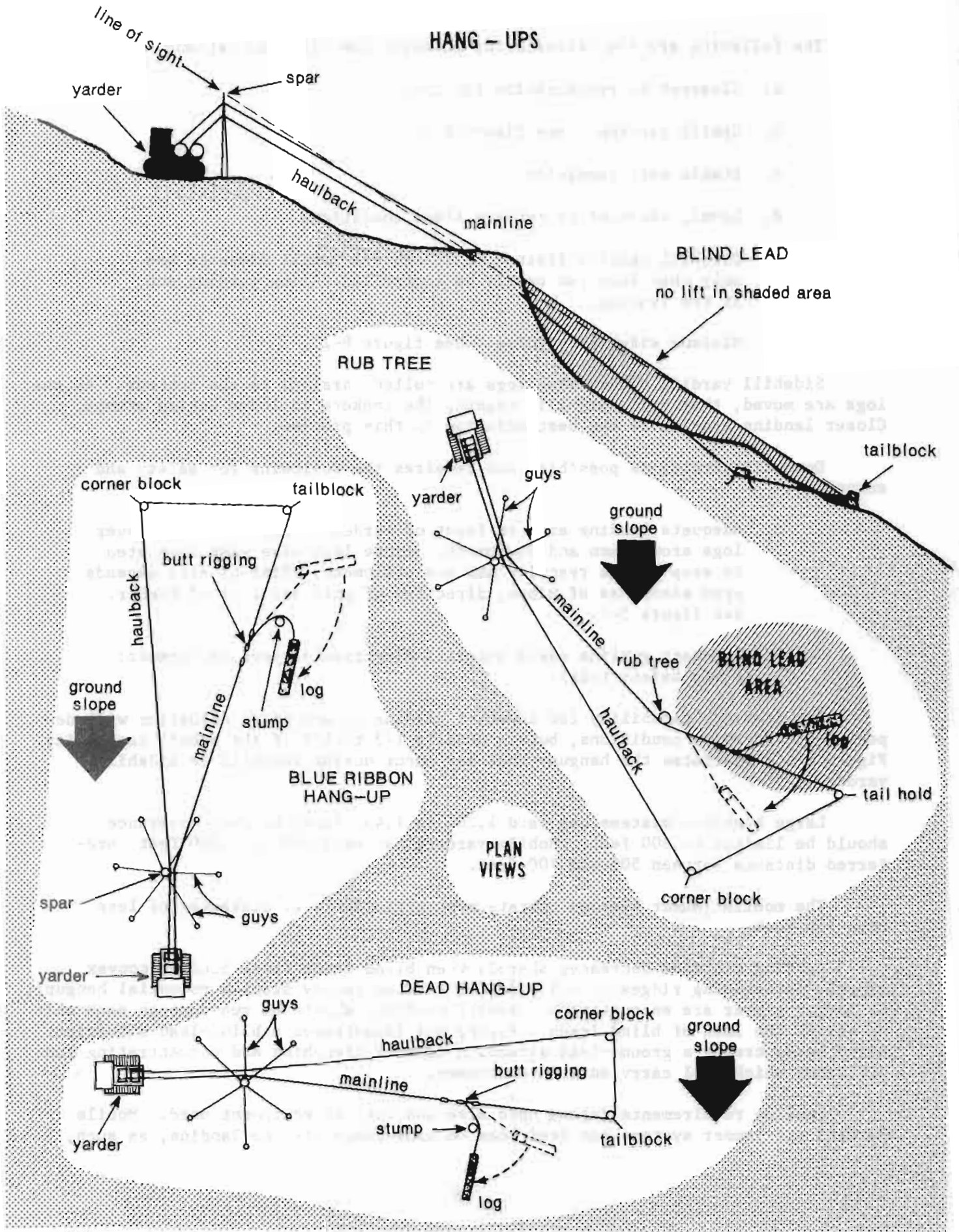

FIGURE 8-2

The following are the criteria for choosing the highlead method:

- a. Clearcut or regeneration cutting.
- b. Uphill yarding. See figure 8-1
- c. Stable soil condition
- d. Level, constant or concave slope conditions
- e. Downhill yarding limited to 1/3 to 1/2 uphill distance and only when logs can safely be controlled during yarding and at the landing.
- f. Minimum sidehill yarding. See figure 8-2

Sidehill yarding occurs when logs are pulled parallel to the contour. As the logs are moved, they roll downhill, causing the chokers to lodge behind stumps. Closer landing spacing is the best solution to this problem.

Downhill yarding is possible, but requires the following for safety and economics:

- a. Adequate landing area in front of yarder to assure control over logs around men and equipment. Loose logs also must have area to stop before reaching men and equipment. Size of area depends upon steepness of slope, direction of yard and size of timber. See figure 3-1.
- b. Adequate guyline angle opposite direction of yard (Reference: State Safety Code).

The distance capability for downhill yarding in any given situation will depend upon the above conditions, but is usually 1/3 to 1/2 of the uphill capability. Figure 8-2 illustrates the hangups that may occur during downhill or sidehill yarding.

Large highlead systems can yard 1,200 to 1,400 feet; however, distance should be limited to 800 feet. Mobile yarders can yard 800 to 1,000 feet, preferred distance between 500 and 700 feet.

The mobile jammer systems operate most efficiently at distances of less than 450 feet.

Yarding distance decreases sharply when blind leads (rock bluffs, convex slopes, intervening ridges, etc.) sidehill yarding (every stump a potential hangup), or larger timber are encountered. Several profiles should be run through each unit to verify the lack of blind leads. Figure 8-2 illustrates a blind-lead situation. Blind leads create a ground-lead situation causing trenching and concentrating run-off water which will carry soil into streams.

Landing requirements depend upon size and type of equipment used. Mobile yarders and jammer systems can land logs on haul roads with no landing, as such,

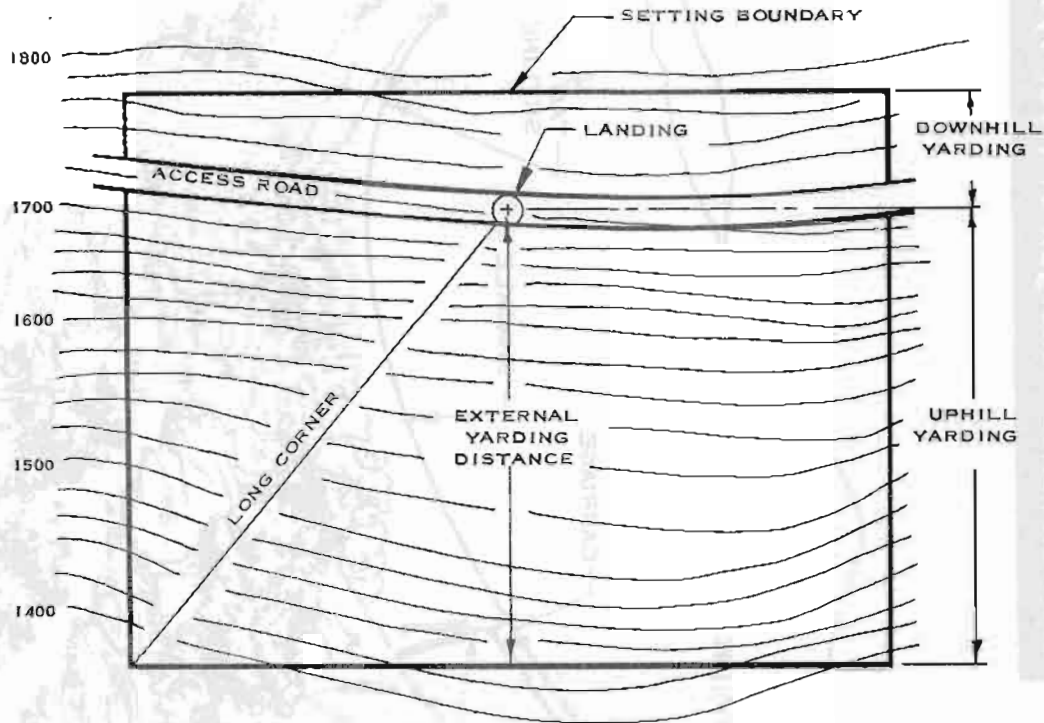

PLAIN VIEW HIGHLEAD SETTING

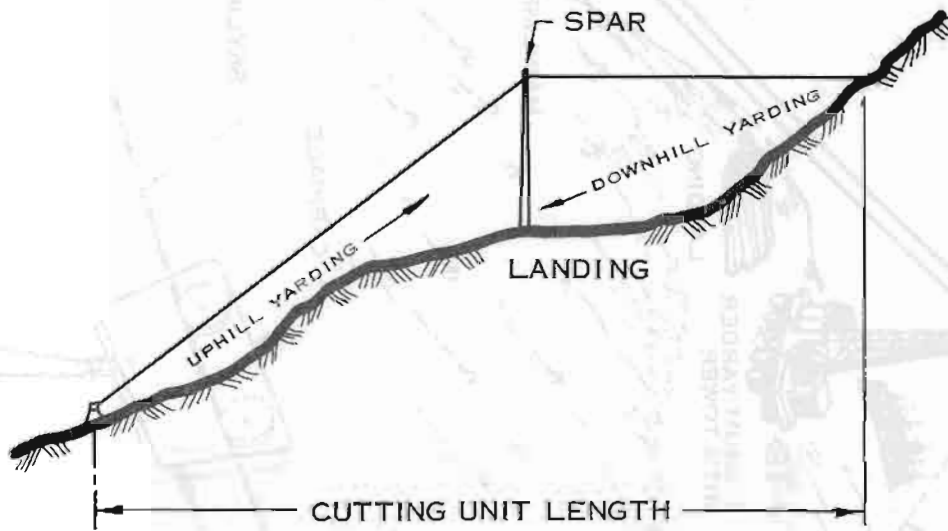

GROUND PROFILE SHOWING DOWNHILL YARDING

Figure 8-3

LIVE SKYLINE - shotgun or flyer system

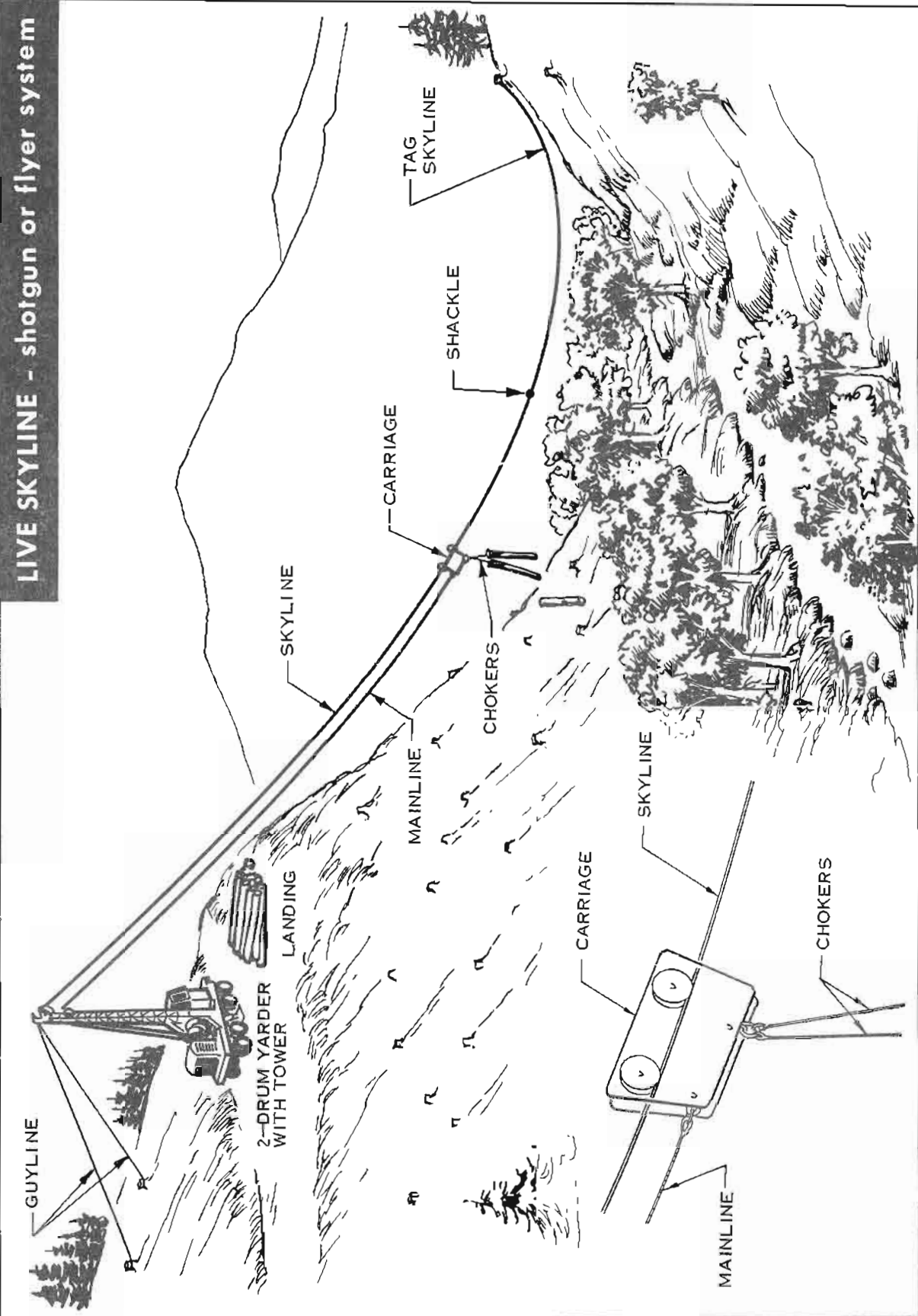

FIGURE 8-4

required. The large highlead systems usually require a landing of approximately 80 by 120 feet. Size varies with equipment used and logs handled. Landing sites should be selected in the field, to verify that adequate skyline anchors are available.

Highlead unit boundaries should be planned to avoid exposure to wind and resulting windthrow. If slashburning is contemplated, firebreaks such as ridgelines or stream courses normally become boundaries. External yarding distances and long corners should be field measured. Figure 8-3 illustrates a plan and profile view of a highlead setting showing the external yarding distance and the long corner. Care should be taken to insure that these distances do not exceed the line capacities of the main and haulback drums.

Live Skylines (figure 8-4)

The most common live skyline system is the modified highlead, or more commonly referred to as the shotgun or flyer. The mainline of the highlead system is used as a skyline and the haulback of the highlead system is used as a skidding line or mainline to move the carriage up and down the skyline. Most highlead yarders, including the mobile yarders, can be modified for this type of logging. Modifications usually include changing the haulback fairlead so that the haulback line on a highlead machine comes out under the mainline. This prevents the haulback from sawing the mainline while used in the skyline configuration.

Other modifications, which are not necessary on most modern highlead yarders may include (1) Adding a larger engine to increase power; (2) changing the gear ratio on the haulback drum to increase line speed; (3) adding a hydrotarder or water-cooled brake to the haulback drum to provide a retarding force for lowering the carriage downhill with or without a turn of logs; and (4) adding larger brakes on the skyline drum.

Yarding distance is limited to the line storage on the mainline drum which is the length of the skyline. In many instances, better deflection is obtained by shackling a piece of skyline and anchoring higher on an opposing hillside. If the carriage cannot pass over a shackle, then the external yarding distance cannot exceed the distance from the landing to connector of the two cables. Some carriages are equipped with skyline sheaves with extra-wide throats, allowing them to pass over shackles. Flyer or shotgun carriages used with these systems may be shop-built or of standard manufacture. Standard slackline carriages and commercial radio-controlled carriages are also adaptable to the live skyline.

When using the flyer or shotgun carriage which cannot skid laterally, the skyline road must be changed often. Generally, skyline roads for this type of carriage are 40 to 50 feet wide. Lateral yarding is accomplished by using long chokers, some as long as 70 feet. If slackpulling carriages are used, skyline roads up to 300 feet wide may be yarded. Where tailholds are scattered or expensive to rig, there is an advantage in using a slackpulling carriage.

This system is strictly an uphill yarding system with landing at the top and gravity outhaul on the carriage. (Under some conditions, the landing could be at the bottom, but the yarder is still located on top of the setting). Partial cutting in buffer strips may be accomplished when using a slackpulling carriage; but when the flyer or shotgun carriage is used, partial cutting is generally impossible due to lateral skidding.

The flyer or shotgun system has several advantages over the highlead system. First, the haulback line is eliminated. This is an important fire and safety consideration. There are no running lines located around the outside of the unit to create a fire hazard, and men are never working in the bight of the line. In the shotgun configuration, choker-setters use lighter (5/8-inch, 3/4-inch and 7/8-inch) chokers instead of the 1-1/8-inch, 1-1/4-inch and 1-3/8-inch chokers normally used in highleading. With the shotgun system, the log can be either partially or totally-suspended during yarding. This results in minimal soil disturbance and log breakage. And utilization with shotgun yarding is 25% to 50% higher than on a highlead side.

One operator, using the shotgun system, reported salvaging, in one year, approximately seven million board feet of small cedar which normally would have been broken during highleading. Higher production, too is realized from the shotgun system.

To substantiate the higher production rate, one large operator reported that his shotgun system produced up to 470 logs per shift, while his highlead side produced only 220 logs per shift. Both operations were in near-ideal conditions. The increased production can be credited to the difference in line speeds. The in-haul speed of the main drum on a highlead yarder with a full turn of logs is generally between 100 and 300 feet per minute. In the shotgun configuration, inhaul speeds of the haulback drum with a full turn of logs may reach 1,000 feet per minute, with outhaul speeds of over 2,000 feet per minute. Shotgun system landings are usually about the same size as highlead landings. However, in some cases, shotgun landings may be larger, due to the greater production capacity.

The live skyline system can also be used with radio-controlled grapples (figure 8-5). The advantage over the normal shotgun system is that a two-man yarding crew can be employed, where the standard shotgun side requires five to six men. Grapples have an added safety advantage. The spotter--the man out in the woods directing the grapple over the log--is usually 50 to 100 feet from the log. The system requires no chaser at the landing. The grapples are opened remotely by a radio signal, also reducing accident exposure.

With some highlead yarders, the radio-controlled grapples may be used with a running skyline, which adds the advantage of downhill, as well as uphill yarding. In both live skyline and running skyline configurations, production with radio-controlled grapples depends upon the size of timber yarded. These machines will usually yard between 125 and 140 pieces per day, irregardless of the piece size. When yarding in small second-growth material, average production probably will not exceed 35,000 board feet per day. On the other hand, when yarding in large old-growth material, production of over 100,000 board feet per day may be obtained. Since there is no lateral capability with the radio-controlled grapples, only those logs directly under the skyline can be picked up. When yarding bucked logs 23 to 44 feet long, a large number of road changes are necessary.

The width of the road can be increased by adding a dutchman to sideblock the skyline (figure 8-5). This is only possible with a three-drum or slackline machine. The skyline and mainline are rigged as in the shotgun system. The haulback line is then run around the unit and attached to a dutchman block on the skyline. During the yarding cycle, the dutchman line is tensioned and the skyline is slacked to pull the skyline to the side, to center the carriage over the log to be picked up. Once the log is grappled or choked, the dutchman line is slackened, allowing the

LIVE SKYLINE with Dutchman

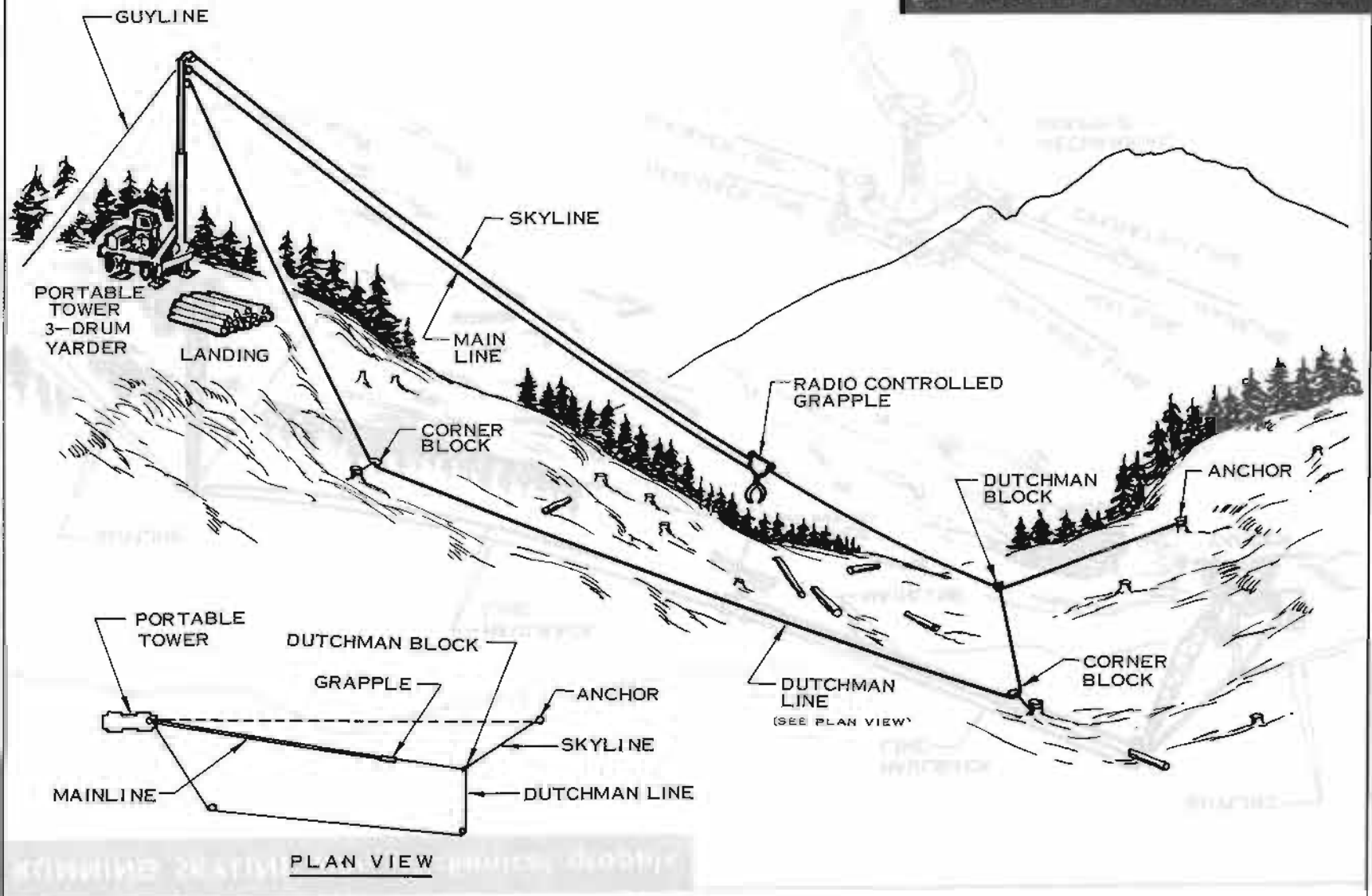

FIGURE 8-5

RUNNING SKYLINE with mechanical grapple

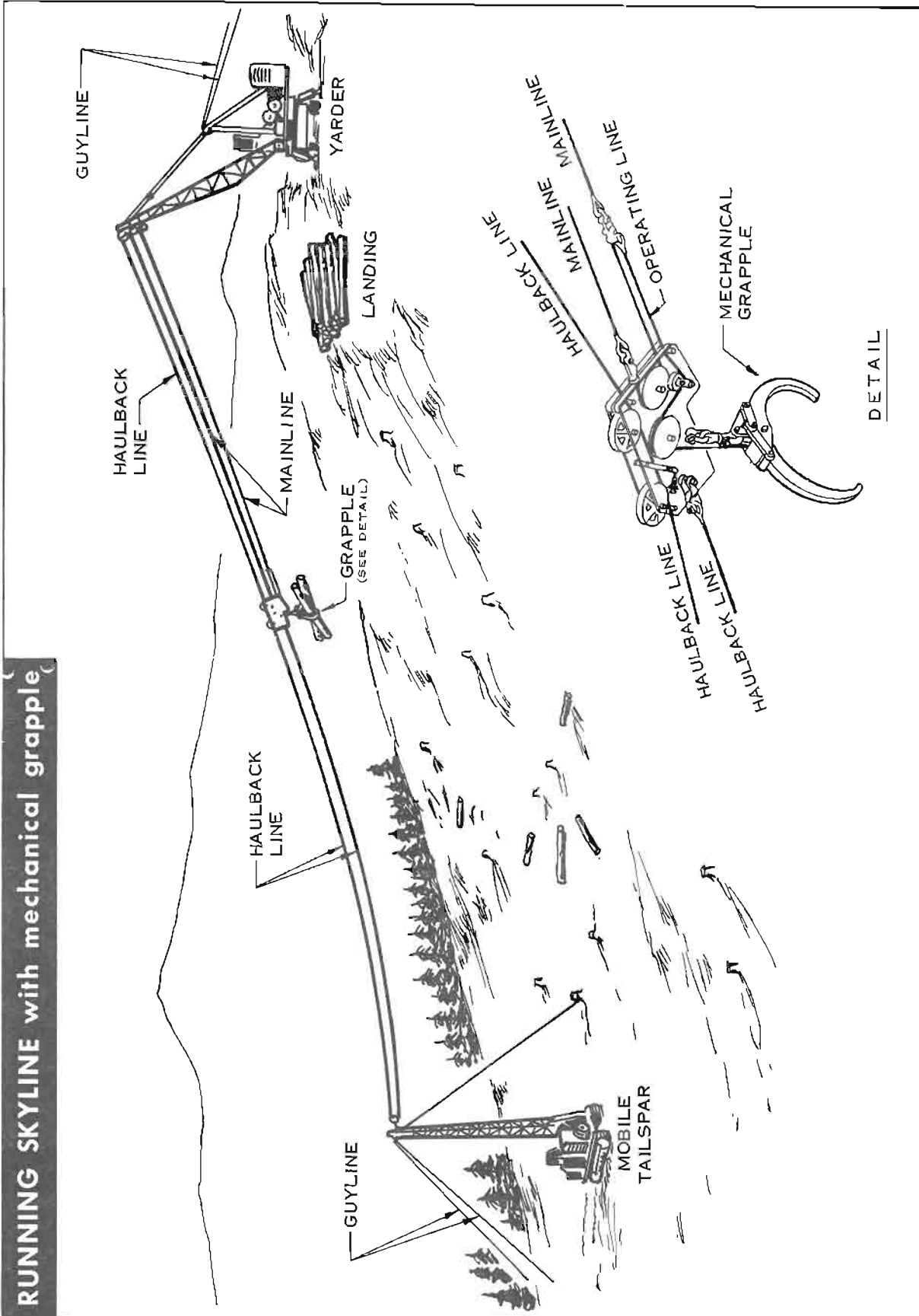

FIGURE 8-6

skyline to move back to its normal position when tensioned, and to lift the log from the ground. Where good deflection is available, the dutchman line remains tensioned and the skyline does not swing back into its normal position each time. Since forces can be developed in the dutchman line equal to those in the skyline, both must be equivalent in size.

Since the shotgun system relies on gravity for carriage outhaul, yarding cannot be accomplished beyond the point where the carriage will no longer move under its own momentum. This point will be close to the belly of the skyline. If yarding is to be done beyond this point, a haulback line will be needed to pull the carriage further out the skyline.

A system that employs a haulback line in addition to the mainline and skyline is called a slackline (See figure 9-7). All three lines are spooled on drums that are contained on the yarder. Because there is a means of pulling the carriage out, this system can be used for yarding downhill or yarding a facing hillside. By adding a haulback line, the advantages of the flyer system, as related to fire, safety, and production, are lost.

Running Skyline (figure 8-6)

The running skyline is becoming more popular for yarding clearcuts, especially with a mechanical grapple carriage. The yarder normally uses a haulback line about 2,000 to 2,500 feet long. The drums are interlocked through gears or hydraulics, or water-cooled brakes are used to equalize the speeds and tensions in all the lines. These machines can generally yard uphill as well as downhill.

The second mainline is sometimes called the "operating line", used to open or close the grapple. This system eliminates the radio equipment in the carriage. The running skyline mobile yarder does not require a large central landing. It works its way down a road, cold-decking logs alongside as it proceeds. Most of the yarders have swinging booms to facilitate decking and loaders later load out the logs.

Since the tower on the running skyline is relatively short, 35 to 55 feet, a mobile tail-spar--usually a short tower on a retired tractor--may be employed to gain additional deflection. The yarders have two or three guylines, instead of the six to eight guylines normally needed by the larger portable towers. This makes them quite mobile and easy to move.

When a grapple carriage is used with this system, two men are needed for yarding. The crew consists of a yarder operator and a spotter in the brush who remotely positions the grapples over the logs to be yarded. With lights mounted on the spar of the yarder, grapple yarding can be continued at night. Night production generally has been equal to daytime production (150 to 200 pieces per shift) because the day crew prepares the area for the night shift.

The running skyline grapple system with a 1,000-foot reach is compatible with future management activities. Lightweight equipment used for thinning requires the same road and landing development. In contrast, a standard highlead or large skyline system requires a totally different road and landing system.

European Systems, Figure 8-7 & Multispans, Figure 8-8

European skyline systems are often used with intermediate supports. Therefore, multispan skylines will be included in this section on European systems.

EUROPEAN SKYLINE SYSTEM

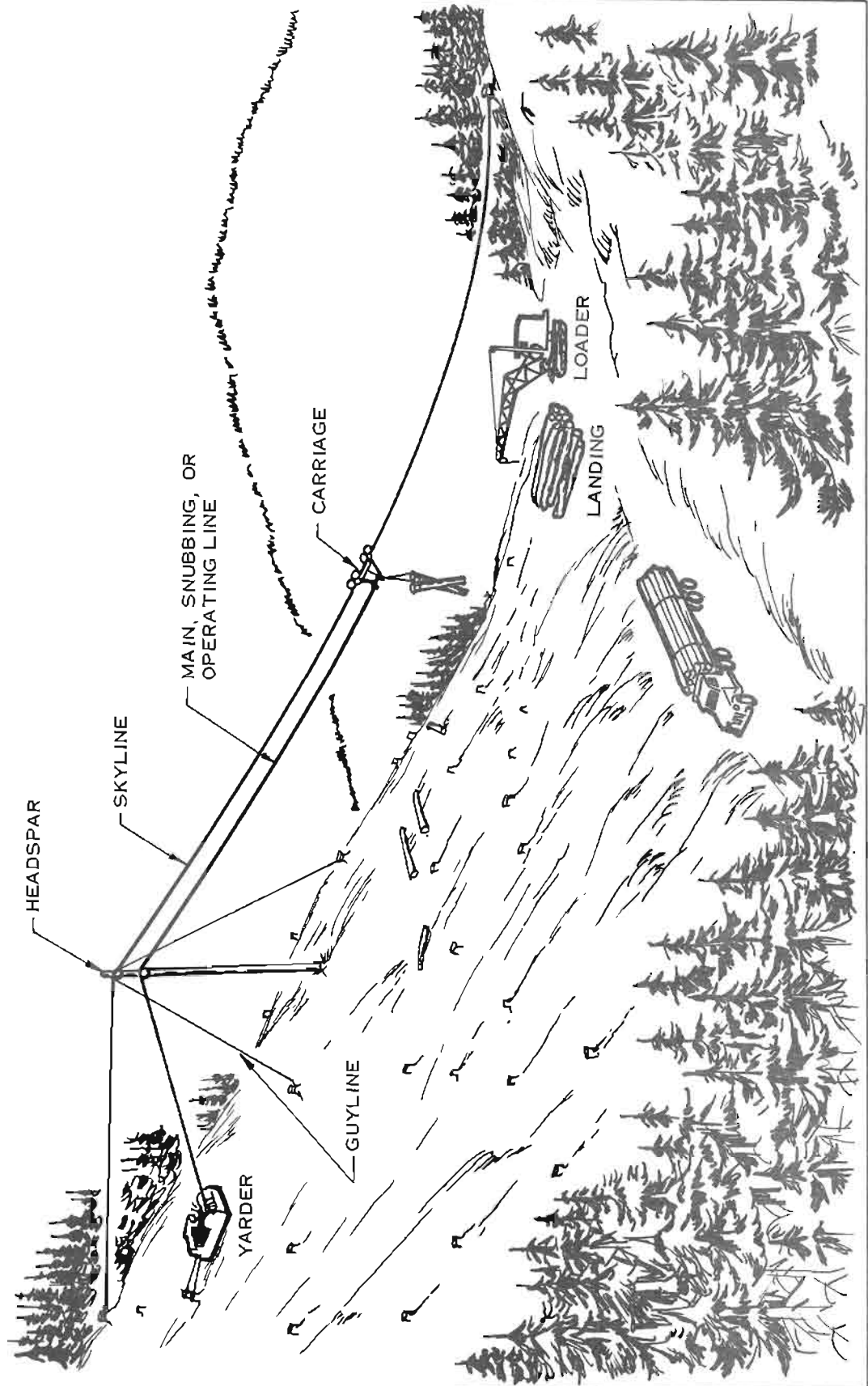

FIGURE 8-7

MULTISPAN SKYLINE

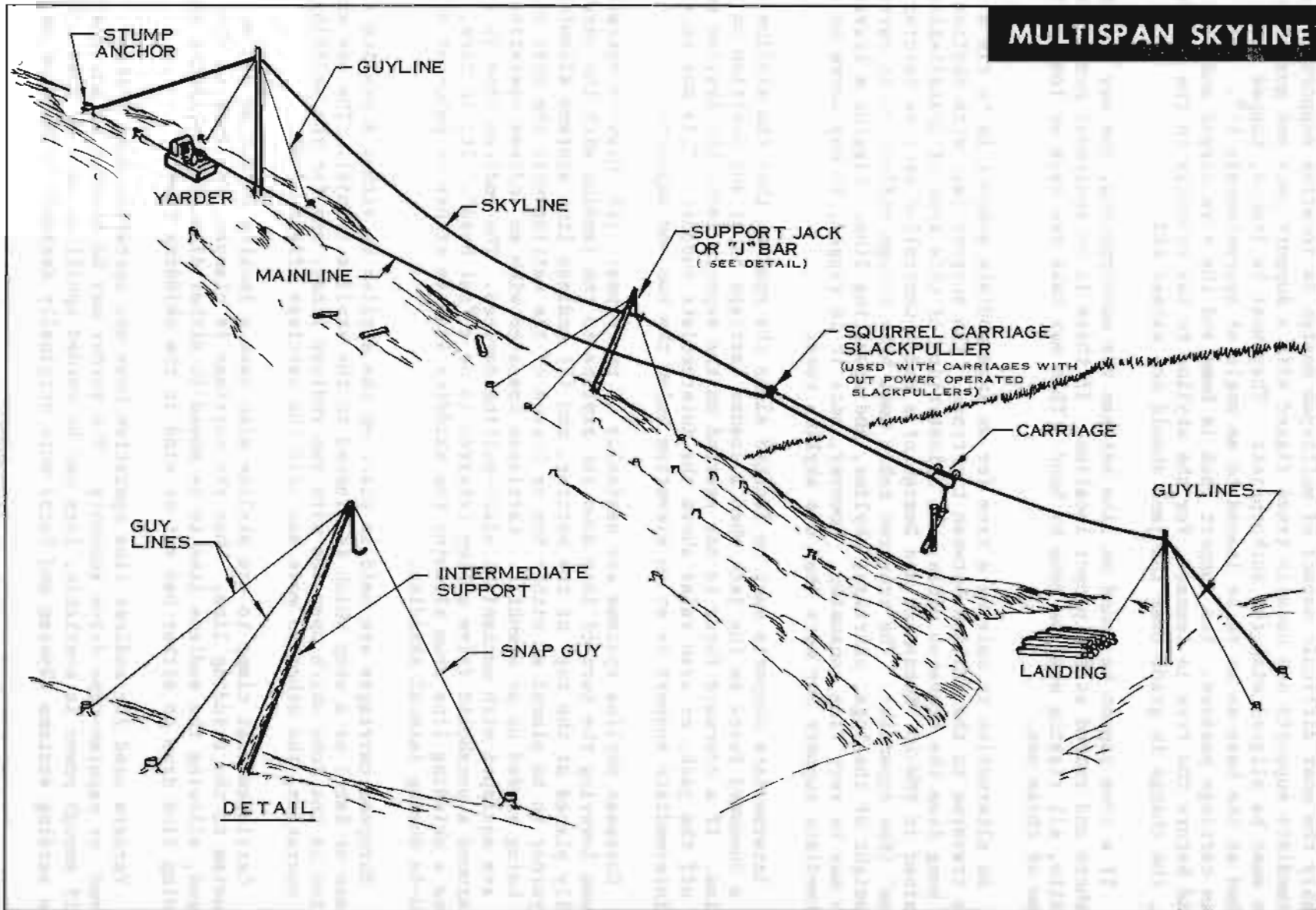

FIGURE 8-8

Multispan skylines are nothing more than a series of standing single-span skylines and are best suited for convex slopes. The method for determining multi-span load limits is outlined in Skyline Tension Deflection Handbook (See Appendix). Probably the most difficult aspect of multispan design is locating support devices. Intermediate supports are usually trees rigged with a support jack and guylines. These must be aligned with the anchorpoints. They must be limbed, topped and notched at the base so as to be leaned to an angle of approximately 14° . This allows carriage passage. The support jack is hung and the guys rigged and tensioned before the tree is leaned. For the skyline to lay properly in the support jack, the change in grade over the jack should not exceed 66%.

If a tree cannot be found on line between the anchorpoints, one may be cut elsewhere and raised at the proper location. If there is no equipment access to the site, all rigging must be done by hand. This may take two days or longer with a crew of three men.

An alternative to raising a tree for an intermediate support is to rig a cable traverse to the skyline between two trees. The support jack with skyline is then hung from the traverse cable. An illustration of this type of installation is contained in PNW-25 "Economics and Design of a Radio-Controlled Skyline Yarding System" (See Appendix). The traverse cable must have enough deflection to carry the weight of the logs, carriage, skyline, and operating line. Rigging a traverse cable may be very time consuming. However, once it is rigged, it may serve as an intermediate support for more than one skyline road.

Intermediate supports must be located along the span so that the skyline exerts a downward force on the jack when a loaded carriage is at any position on the skyline. If a downward force is not exerted on the support jack, the skyline may lift off the jack, or even raise above the intermediate support. This may occur if the intermediate support is at an elevation below the two end supports.

European skyline systems are basically of two types: (1) Gravity-operated systems lowering the turn of logs down the skyline to the landing with the yarder usually placed at the top of the setting, and (2) endless line systems allowing the yarder to be placed at either top or bottom of the setting with the turn of logs being yarded up or downhill. Carriages operated with an endless operating line are equipped with mechanical slack-pulling devices. The endless line is wrapped around a parabolic drive pulley referred to as a "cat head". It, in turn, drives a skidding line drum allowing the skidding line to either be paid-out or wound-in during lateral skidding.

European carriages are held in place on the skyline by either a skyline clamp (Wyssen or Baco) or a stop which is clamped to the skyline (Vinje). The one exception is the Jobu which operates with two endless lines; one for the skidding line operation, the other to move and hold the carriage (figure 8-9).

Carriages that clamp to the skyline also have a locking device on the drive mechanism to the skidding line. When the carriage is clamped, the lock is disengaged, allowing the endless line to be moved in either direction, rotating the skidding line drum to either pay out or wind in the skidding line.

Yarders used for endless line operation have one operating drum with a grooved or capstan-type drive assembly. The yarder may be located at any position and if enough power is available, logs can be yarded uphill as well as down. The Swiss yarding systems (Wyssen and Baco) were originally designed to be used as

EUROPEAN CABLE CRANES

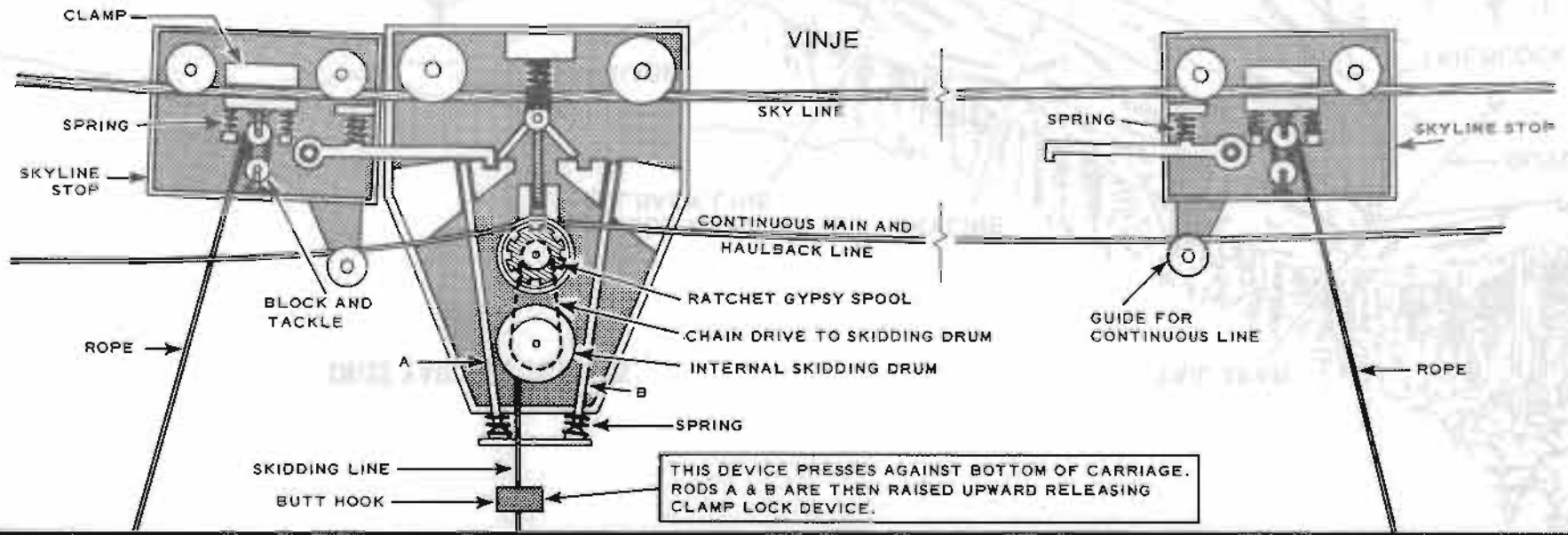
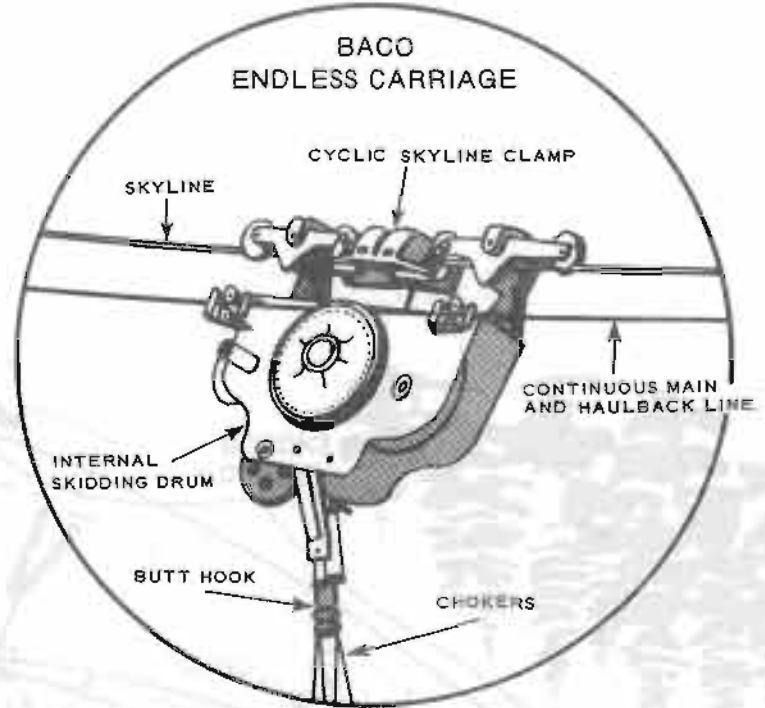
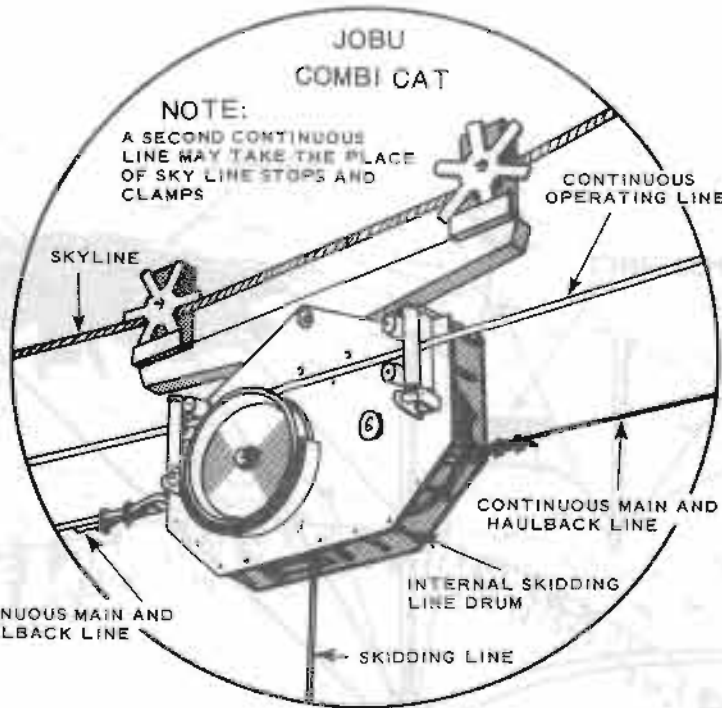

Figure 8-9

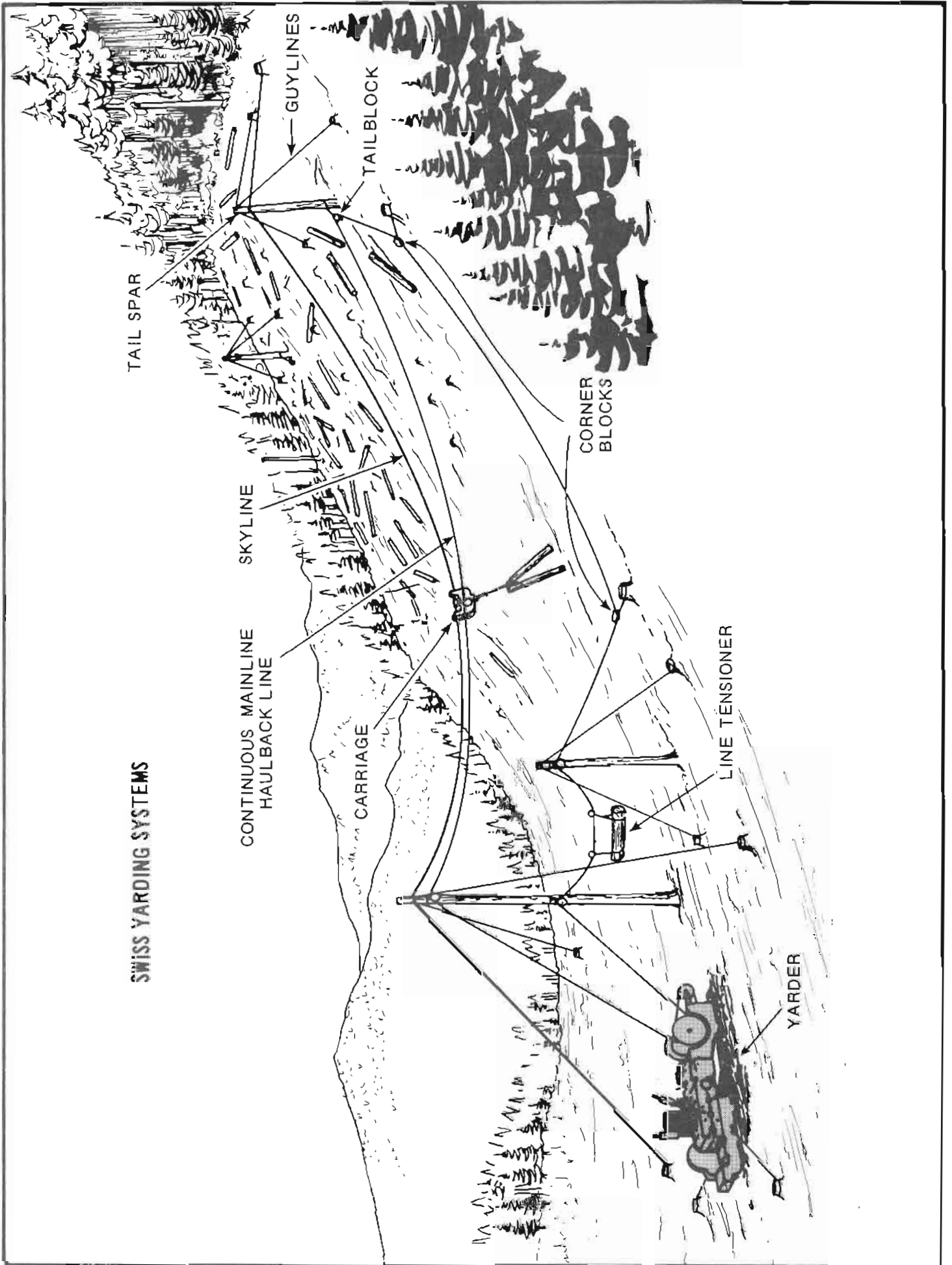

Figure 8-10

gravity systems (figure 8-7), however, the yarders may be converted to the endless line system (figure 8-10). Skyline sizes may be one-inch or larger and the endless line, depending on size of yarder, ranges from 3/8-inch to 9/16-inch diameter. Rigging these systems requires splicing the endless line for each setting. Also, the proper tension must be maintained in this line.

Initially, the endless line is tensioned by moving the yarder until the line becomes tight. During operation, tension may be maintained by suspending a weight, usually a log, on the line (figure 8-10). Baco and Wyssen equipment are functionally the same except in the carriage clamp device functions. Baco's clamp is operated mechanically, while Wyssen's clamp combines hydraulic and mechanical operation. Yarding distances range up to 5,000 feet. If access is not available to the back end for rigging, small helicopters may be used to drop strawline and blocks.

Norwegian yarders (Vinje or Jobu) are controlled remotely by radio or by remote cables similar to those used to operate shop cranes. These systems require a minimum of two men, contrasted with possibly four men for non-remote-controlled yarders.

The Vinje radio-controlled cable system (figure 8-11) yarder may be mounted on a 100-hp farm tractor or a 1-1/2-ton truck powered by a 100-hp diesel engine. The system may be used as a single span as well as in multispan installations and logs may be transported either uphill or downhill.

The Jobu has two endless operating lines. One line operates the skidding-line drum on the carriage, while the other either holds the carriage in a fixed position, or moves it up and down the skyline (figure 8-12). The yarder is controlled by the chaser through a panel connected by electrical cable to the yarder. Normally, the yarder is positioned at some distance from the landing. The system can be used in stands up to 16 inches DBH. Its major disadvantage is the difficulty of rigging two endless lines.

The two most common European skyline systems used in the United States are the Wyssen and Baco. These can yard distances up to 5,000 feet with lateral skidding distances of 200 feet. However, 150 feet of lateral skidding on either side of the skyline is considered optimum. With both Baco and Wyssen systems, the yarder, or snubber is located at the top of the unit and the logs are lowered downhill by gravity (figure 8-7). Intermediate supports can be used with either; however, operation with a single span is more economical.

These systems have not been particularly popular in the United States, primarily because of their low production and relatively high manpower requirements. They require a five or six-man crew which normally produces 20,000 to 25,000 board feet daily. On most logging shows, the equipment operates from five days to a month on a single setting. Then it is down for five to eight days while the skyline is moved and rigged. Yarding production over an extended period will average 10,000 to 15,000 board feet per day or 1-1/2 to 2-1/2 million board feet per year.

With this relatively low production, loading is a serious problem. Cost is extremely high if a loader is kept on the landing at all times. Loaders can handle 20 to 25 loads per day, while the yarding equipment can produce only two or three loads per day--and in some cases, four. The alternative is to make large cold-decks for later loading. This is normal for the Wyssen and Baco systems. Since they are designed for downhill yarding with the yarder or snubber at the top of

VINJE
Norwegian Cable Crane
With One Endless Line

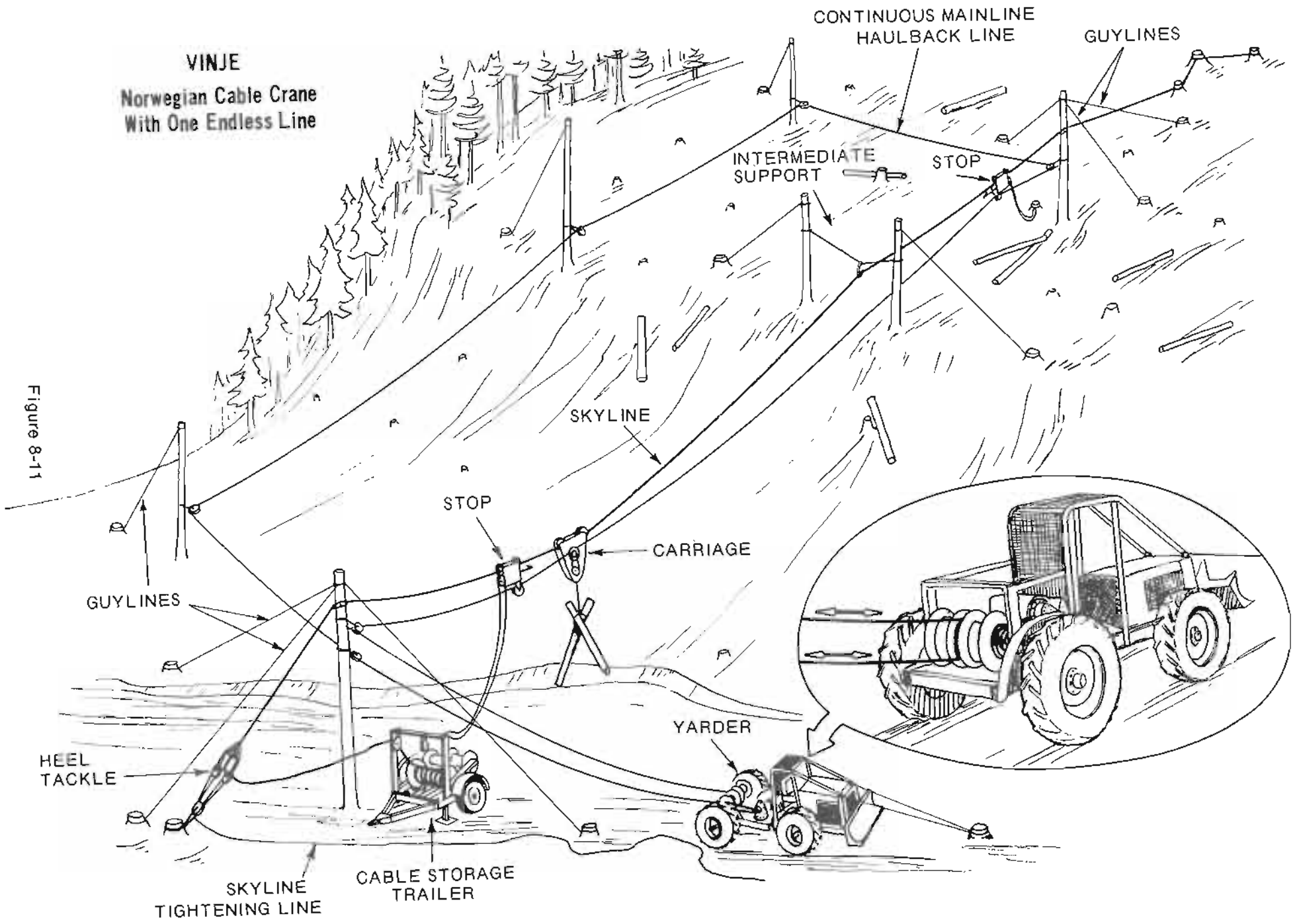

Figure 8-11

Norwegian Cable Crane With Two Endless Lines

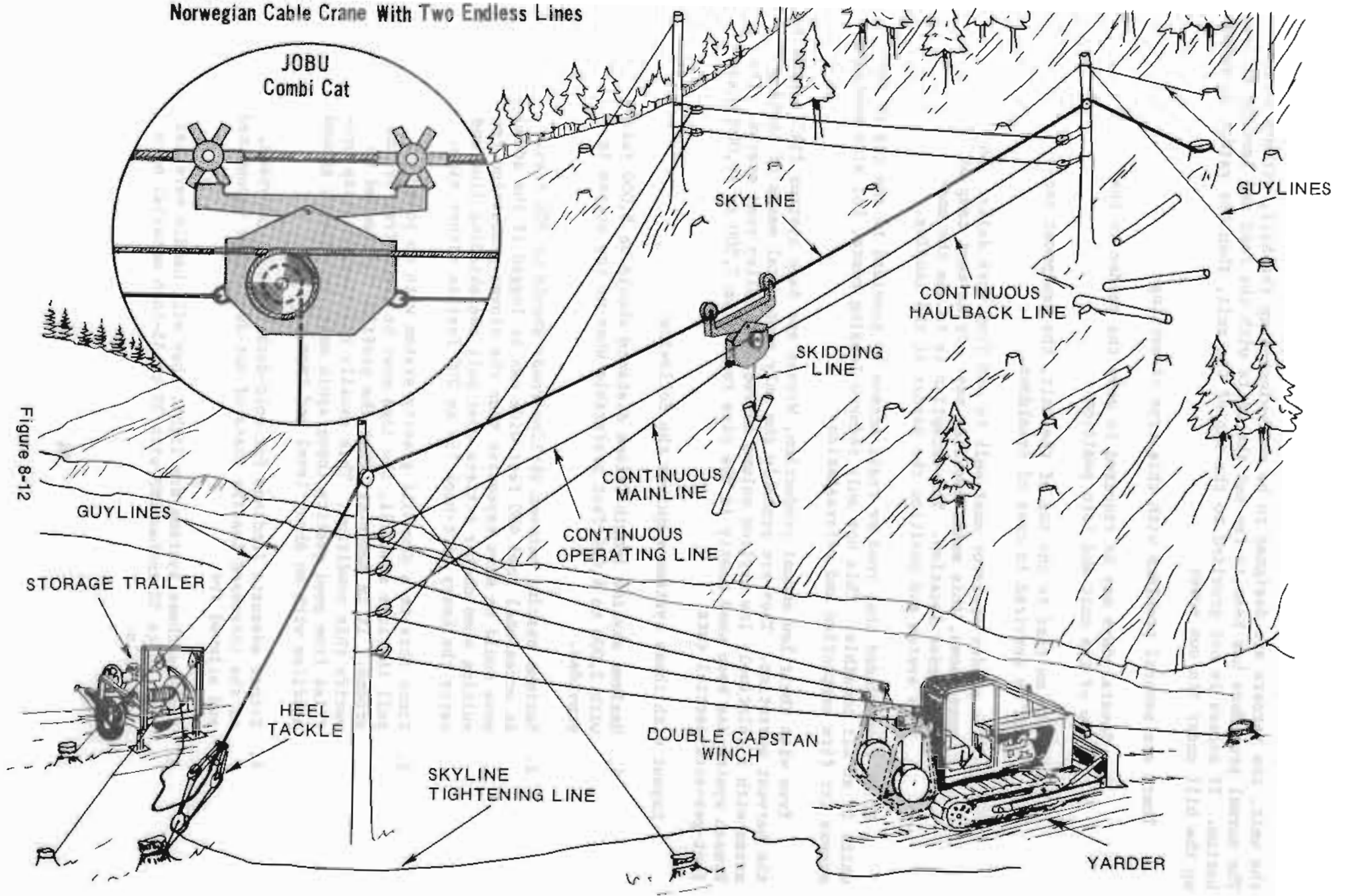

Figure 8-12

the unit, the yarders are designed to be self-winchd up the hill, without roads. The normal procedure has been to lay out the units with the road and landing at the bottom. If access is not provided to the top of the unit, then the yarder is moved up the hill under its own power.

There are several problems with this type of setting.

1. Several days may be required to move the yarder to the top of the unit and into position.
2. With no road to the top of the unit, the equipment cannot be serviced in case of breakdown.
3. The yarder operator must walk to and from work daily. In many cases, this means overtime pay. Or he must camp at the yarder location. The exception is to use the endless system and position the yarder at the landing.

It is recommended that road or trail access be provided to the top of the units if at all possible. This not only reduces logging costs, but also provides access for fire protection and reforestation.

Even with their low annual production, Wyssen and Baco systems fill a need in the harvest operation. They are probably the only economical means of logging areas with a relatively low skyline volume served by a valley road system. The Wyssen system has been used mostly in the pine regions in 7,000 to 10,000 board-foot-per-acre partial cuts.

Layout with these systems requires the following:

1. Maximum skyline length (slope distance) should be 5,000 feet with 3,000 to 4,000 feet preferable when no top access is provided.
2. Maximum spacing between skyline roads should be 300 feet. An occasional road 400 feet wide can be logged if the added move would be more expensive than the slower production resulting when choker setters must pull the skidding line and carry the heavy butt-hook 150 to 200 feet to either side.
3. Since this is a downhill gravity system with no power to pull the logs downhill, the logs must be flown free of the ground. It is mandatory that the profiles be checked to verify this condition. This usually requires plotting profiles from good quality topographic maps, or running ground profiles with an Abney level and tape.
4. Either adequate landings for cold-decks must be provided, or the increased loading costs of hot-decking be recognized and allowed for.
5. Because these systems are light, they will handle material only up to 50 inches DBH with 30 to 35-inch material more desirable.

STANDING SKYLINE - radio controlled carriage

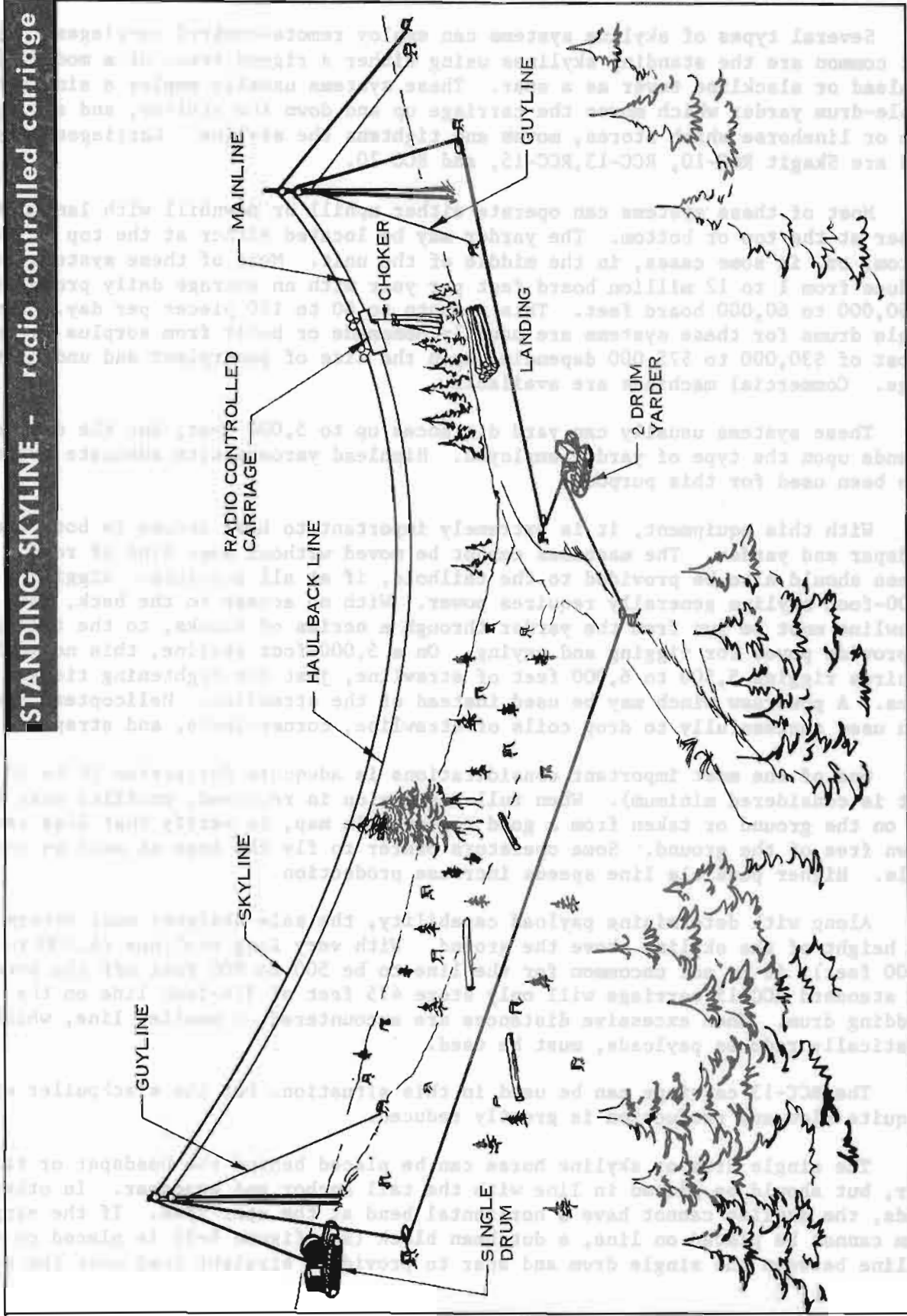

FIGURE 8-13

Standing Skylines with Radio-Control Carriages
(Figure 8-13)

Several types of skyline systems can employ remote-control carriages. The most common are the standing skylines using either a rigged tree, or a modified highlead or slackline tower as a spar. These systems usually employ a single or double-drum yarder which moves the carriage up and down the skyline, and a single drum or linehorse which stores, moves and tightens the skyline. Carriages normally used are Skagit RCC-10, RCC-13, RCC-15, and RCC-20.

Most of these systems can operate either uphill or downhill with landings either at the top or bottom. The yarder may be located either at the top or the bottom, or, in some cases, in the middle of the unit. Most of these systems can produce from 1 to 12 million board feet per year with an average daily production of 50,000 to 60,000 board feet. This amounts to 80 to 120 pieces per day. The single drums for these systems are usually homemade or built from surplus parts at a cost of \$30,000 to \$75,000 depending upon the size of powerplant and undercarriage. Commercial machines are available.

These systems usually can yard distances up to 5,000 feet, but the distance depends upon the type of yarder employed. Highlead yarders with adequate brakes have been used for this purpose.

With this equipment, it is extremely important to have access to both the headspar and yarder. The machines cannot be moved without some kind of road. Access should also be provided to the tailhold, if at all possible. Rigging a 5,000-foot skyline generally requires power. With no access to the back, the strawline must be run from the yarder through a series of blocks, to the tailhold to provide power for rigging and guying. On a 5,000-foot skyline, this normally requires rigging 5,500 to 6,000 feet of strawline, just for tightening tieback lines. A powersaw winch may be used instead of the strawline. Helicopters have been used successfully to drop coils of strawline, cornerblocks, and straps.

One of the most important considerations is adequate deflection (8 to 10 percent is considered minimum). When full suspension is required, profiles must be run on the ground or taken from a good topographic map, to verify that logs can be flown free of the ground. Some operators prefer to fly the logs as much as possible. Higher possible line speeds increase production.

Along with determining payload capability, the sale designer must determine the height of the skyline above the ground. With very long skylines (4,000 to 5,000 feet), it is not uncommon for the line to be 500 to 900 feet off the ground. The standard RCC-15 carriage will only store 475 feet of 3/4-inch line on the skidding drum. When excessive distances are encountered, a smaller line, which drastically reduces payloads, must be used.

The RCC-13 carriage can be used in this situation, but the slackpuller speed is quite slow and production is greatly reduced.

The single drum or skyline horse can be placed behind the headspar or tail-spar, but should be placed in line with the tail anchor and headspar. In other words, the skyline cannot have a horizontal bend at the spar tree. If the single drum cannot be placed on line, a dutchman block (See figure 8-5) is placed on the skyline between the single drum and spar to provide a straight lead over the spar.

The single drum need not be in the same area as the yarder. Quite often, the yarder and single drum are located on opposite ends of the skyline.

The yarder should be positioned so that the carriage moves downhill by gravity, thus eliminating the need for a haulback line which usually slows production. Use of a haulback line may increase cycle time by 25%. It also increases rigging time.

Since large rigging is used (1-1/4-inch to 2-inch skyline) the tailholds and skyline anchors must be extremely well rigged. Quite often this requires deadman anchors or rockbolts where adequate stumps are lacking.

Landing should be located to provide adequate guyline angles and skyline deflection. A landing located on top of a ridge may provide good deflection, but the guyline angles may be too steep to be effective (Ref: State Safety Codes). Consideration should be given, also, to the skyline angle at the top of the tower. The greater the angle, the greater the compressive force on the tower. The landing may be located below the top of the ridge to increase the effectiveness of the guylines, but this may decrease deflection. A landing in this location may require more excavation, but excavation may be reduced by using a step landing. (See figure 3-4).

Standing Skyline - North Bend (Figure 9-12)

The North Bend was designed primarily as a system to swing logs from remote highlead landing to a landing where the logs could be loaded onto a truck. Recently, the North Bend is being more widely used where one-end suspension of the log is required. By holding tension on the haulback line during inhaul, the turn can be lifted, and if enough deflection and clearance is available, it may be completely suspended.

Side-blocking is accomplished by setting the haulback tailback off to the side. This can be an effective operation in a clearcut, however in an overstory removal, the residual stand will be damaged by the lines. This system, like any other skyline system, requires adequate deflection (8 - 10%) to carry a payload. Generally, the maximum yarding distance is 2,000 feet.

Balloon (Figure 8-14)

Several factors create a favorable situation for balloon logging. First is topography. Where the ground is extremely steep and resulting road costs prohibitively high, the balloon system offers the possibility of logging where no other present method can operate successfully. The primary reasons are:

1. The possibility of yarding up to 4,000 feet. This enables the balloon to overcome roadbuilding limits dictated by topography.
2. The balloon, by means of its vertical lifting capacity, can overcome intervening obstacles and convex slopes. Other systems may require intermediate supports to log the same area. Multispan skylines may not be feasible because of the lack of anchors or intermediate supports.

BALLOON LOGGING - haulback configuration

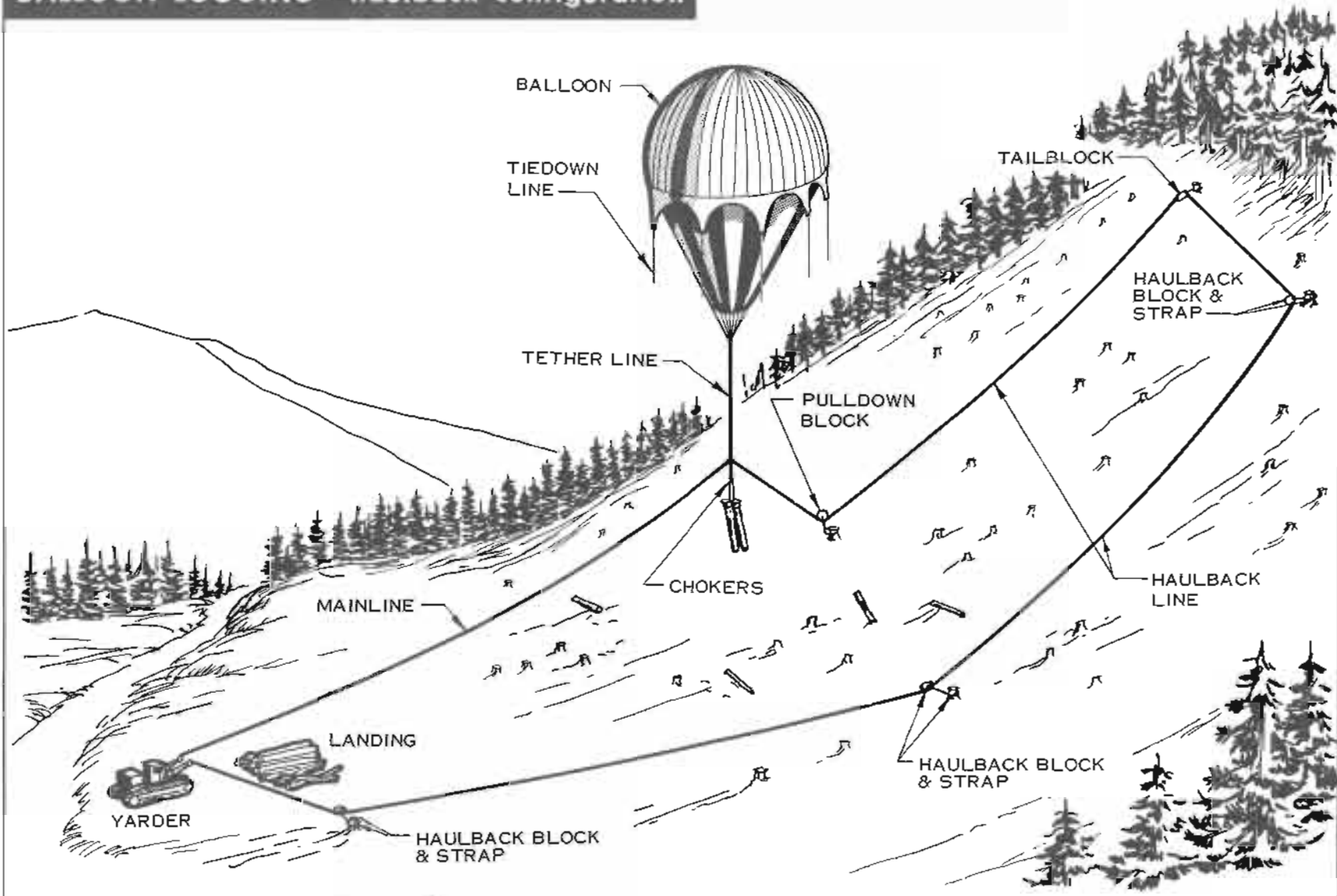

FIGURE 8-14

Second, the balloon is particularly suited for logging where soil erosion is a problem. Its vertical lift enables the load to be entirely airborne. Soil disturbance, as far as the yarding is concerned, is virtually non-existent. Also, the yarding distances possible with this system reduce required road mileages. The only undesirable road requirement is that the main haulroad must usually be built near the bottom of the drainage. Here, soil conditions may be unstable and there is greater possibility of disturbing waterways with road construction. This condition results from the balloon being primarily a downhill yarding system.

A third area where balloon logging can be a useful technique is where aesthetics are of critical concern. Again, because of the balloon's lifting capacity, understory damage is minimized. It is possible to log selectively where one wishes to retain the appearance of an area for scenic or recreational reasons. The only serious drawback to the balloon's use in this manner is that the volume of timber removed must be quite high to make the system economically feasible.

Balloon logging, at this time, is geared to a clearcutting operation. As in other logging methods requiring expensive machinery and equipment, a high volume is necessary. Clearcut unit size may have an effect on the yarding cost. Larger settings tend to reduce the move-in and set-up costs per MFB; but, on the other hand, large settings require more rig-up time. It is felt that increased unit size favors the long-range systems in an economic sense. This, however, will depend to a considerable extent on the layout and orientation of the units. For example, the rectangular-shaped unit, consisting of parallel roads, requires moving the yarding machine for each road. The only benefits obtained, in this case, are in move-in costs per unit and, if the individual roads are longer, more volume per road. However, if the unit is laid out in a fan-shape with the yarder at the apex, only the yarding lines must be moved. This saves the cost of moving the yarder. The terrain must conform favorably to pay out this type of unit.

Fourth, there is substantially less timber breakage from balloon yarding. The logs are airborne, which eliminates breakage from dragging logs on the ground.

Weather plays an important role in logging with the balloon. Some important conditions are:

1. Wind. In 25 to 30-mph wind, resistance to the wind's dynamic force becomes greater than the balloon's designed static lift. This causes erratic movement and loss of control which is of paramount importance in balloon logging.
2. Rain. Water clinging to the balloon's fabric can decrease the static lift 1,000 pounds or more.
3. Snow. Heavy wet snow accumulating on top of the balloon can create a heavy puddle which can settle the balloon to the ground.

Statistics can be obtained from the National Weather Service to determine if balloon logging is feasible for a given area.

Landing size for the balloon system should be approximately 70 x 100 feet. A landing this large is required because of the difficulty in landing logs precisely, especially in gusty winds.

Yarding begins at the top of the unit and progresses down the skyline road. This eliminates the hazard of logs rolling down the hill onto the crew. A pull-down block, which guides the haulback line, is moved down the hill as the yarding progresses. This acts as a tailblock, pulling the butt-rigging down to the ground and overcoming the lift of the balloon in order to hook the turn.

The balloon is moved between sale areas inflated. Travel routes should be checked for overhead obstructions such as powerlines and truss bridges. Load limits on bridges must also be checked to confirm that they can support a 172,000-pound yarder.

A 150-foot-diameter bedding area is needed for subsequent servicing and a ground cloth is necessary to protect the balloon's fabric during initial inflation. One bedding area may serve more than one sale.

The loading systems used with the balloon combines the speed of a rubber-tired front-end loader with the convenience of Batson preload bunks. Heelboom loaders have been used; however, they lack the speed and maneuverability to move in to clear the landing area of logs and load trucks at the same time. Rubber-tired machines have been tried, combined with heelboom loaders, but found to be quite expensive.

OVERSTORY REMOVAL

A great variety of equipment is available for overstory removal. Since this is generally large timber, fairly large equipment is required to remove the wood satisfactorily. The carriage must meet two requirements. It must be capable of pulling slack or having slack pulled through it. And it must be capable of maintaining a fixed position on the skyline during yarding. The lateral yarding capability is necessary to reduce the number of skyline roads and to yard the entire skyline road without destroying the residual stand. Once the timber is skidded to the skyline corridor, it is then yarded up the skyline to the landing. To accomplish this, a carriage capable of clamping to the skyline, or capable of maintaining a fixed position on the skyline is necessary, to minimize residual stand damage. Systems such as North Bend, South Bend and Slackline will not work satisfactorily in an overstory removal. Their use requires pulling the entire skyline sideways. In an overstory removal, or other partial cut, pulling a skyline laterally tears down or damages the residual stand.

The felling pattern in a partial cut is also very important (figure 2-4). Damage to the residual stand occurs during the felling operation and during the lateral yarding operation. To minimize this damage, the herringbone felling pattern is ideal, if the ground is not overly steep and if the fellers know the skyline corridor locations in advance of felling.

When these two conditions do not exist, the next best method is to fall the trees perpendicular to the slope or parallel to the contours. Then the skyline roads are located after felling has been completed. On very steep slopes, downhill felling results in breakage to the timber but very little damage to the residual stand. Uphill felling would eliminate this breakage. However, a mechanical means must be provided to direct the tree uphill.

Most residual stand damage occurs during lateral yarding because of the side deflection of the skyline. On an overstory removal sale, all of the trees are usually felled before the skyline corridors are designated. Therefore, there is little opportunity to leave rub-trees. If the skyline is suspended above the canopy in an overstory removal unit, little damage will result to the residual stand. However, if the skyline is suspended at tree-top height, the tops of the trees along the corridors will be damaged. In general, the more deflection to the skyline, the more the side excursion into the stand.

In intermediate cuts where the residual stem spacing is to be around 20 feet, it is relatively easy to pick out the skyline corridors. For this type of cut, rub-trees can be left to help alleviate the lateral excursion problem.

Another method of reducing lateral excursion is to limit lateral yarding distance. This can be done by contract specifications of maximum and minimum landing spacings. Maximum spacing governs the lateral yarding distance, while minimum spacing limits the number of trees taken out of the corridors. A good lateral yarding distance equals half the stand's overall height.

Fan-shaped settings have another problem. Usually a clear-cut area results when more than one skyline road radiates from one landing or tailhold (figure 2-3). One way to alleviate the problem is to specify in the contract the maximum number of skyline roads radiating from a common point--usually three or four roads.

Skyline corridors should be kept perpendicular to the contours. If the skyline crosses the contour at an angle other than 90° , lateral ground slope will occur (figure 8-15). Yarding across a lateral slope with one end of the log dragging will increase the corridor width. On a lateral slope, the skidding line can be pulled only a short distance uphill from the skyline (Ref: PNW-25). In this situation, more damage occurs to the residual stand during lateral yarding because the logs must be turned before skidding to the skyline, and then turned again to be yarded to the landing.

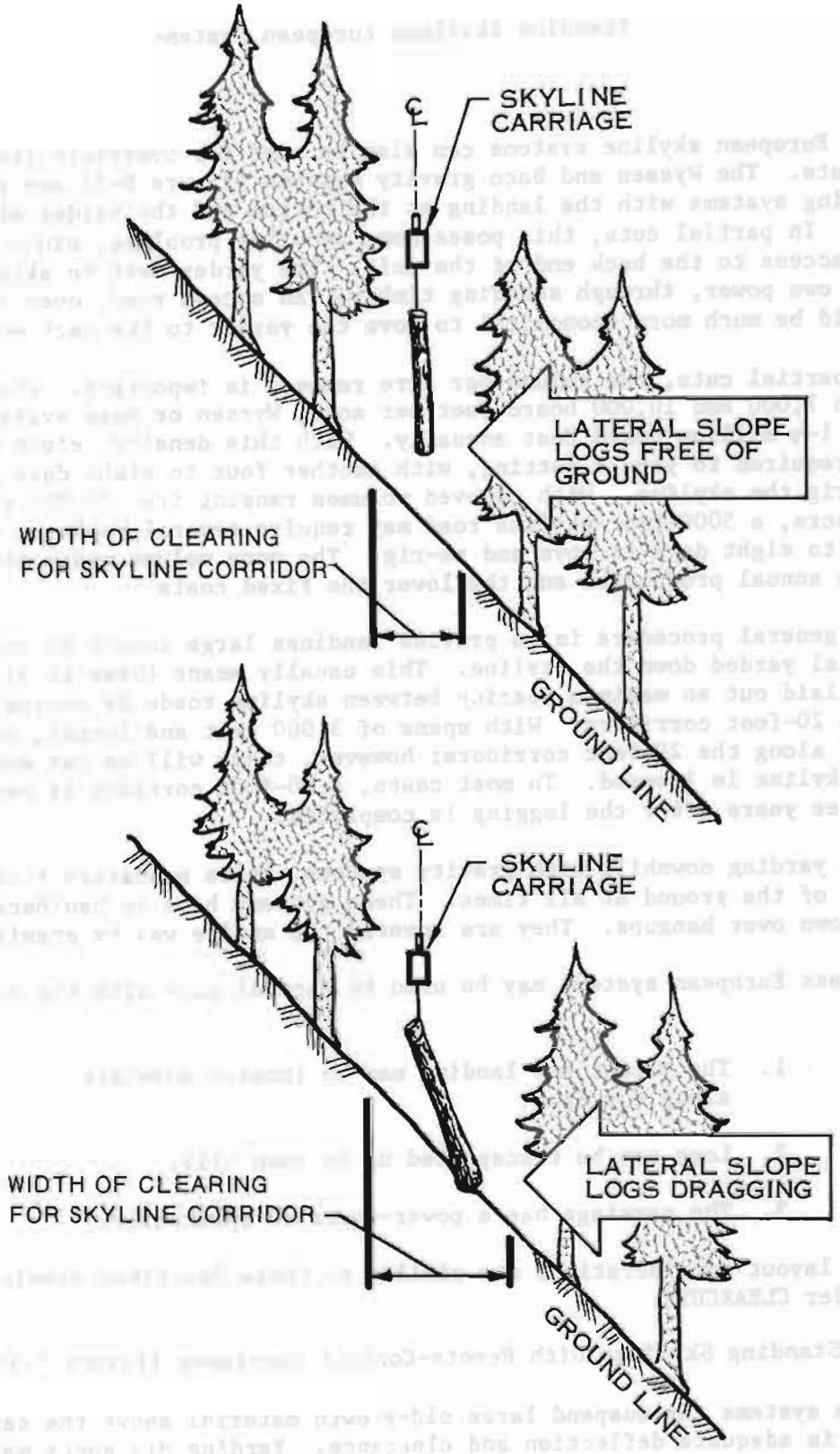

Figure 8-15

Standing Skylines—European Systems

The European skyline systems can also be used for overstory removal or shelterwood cuts. The Wyssen and Baco gravity systems (figure 8-7) are primarily downhill yarding systems with the landing at the bottom and the yarder at the top of the unit. In partial cuts, this poses some peculiar problems, since there is generally no access to the back end of the unit. The yarder must be skidded uphill under its own power, through standing timber. An access road, even a primitive road, would be much more economical to move the yarder to the back end.

In partial cuts, the volume per acre removed is important. When the volume is between 7,000 and 10,000 board feet per acre, Wyssen or Baco systems will produce 1 to 1½ million board feet annually. With this density, eight to fifteen days are required to yard a setting, with another four to eight days required to move and rig the skyline. With removed volumes ranging from 20,000 to 50,000 board feet per acre, a 5000-foot skyline road may require several weeks to yard and another four to eight days to move and re-rig. The more volume under the skyline, the higher the annual production and the lower the fixed costs.

The general procedure is to provide landings large enough to cold-deck all of the material yarded down the skyline. This usually means three to six acres. Sales should be laid out so maximum spacing between skyline roads is approximately 300 feet, with 20-foot corridors. With spans of 3,000 feet and longer, some trees will be damaged along the 20-foot corridors; however, these will be cut and removed before the skyline is lowered. In most cases, a 20-foot corridor is barely visible two or three years after the logging is completed.

When yarding downhill with gravity systems, it is mandatory that logs be flown free of the ground at all times. These systems have no haulback line to pull the logs down over hangups. They are lowered the entire way by gravity.

Endless European systems may be used in partial cuts with the following advantages:

1. The yarder and landing may be located anywhere along the span.
2. Logs can be transported up or down hill.
3. The carriage has a power-operated slackpuller.

Sale layout considerations are similar to those described previously in this chapter under CLEARCUTS.

Standing Skylines With Remote-Control Carriages (Figure 8-16)

These systems can suspend large old-growth material above the canopy, providing there is adequate deflection and clearance. Yarding distances may be up to 4,000 and 5,000 feet with spar trees on one or both ends. Uphill, downhill or a combination of both types of yarding can be accomplished. In some instances, the skyline can be suspended across a canyon and logs landed on a road in the bottom of the canyon, yarding downhill in both directions. The best job of logging occurs

when the logs can be suspended above the canopy; however, this is not necessarily a requirement.

When yarding within the canopy, a corridor 20 to 25 feet wide is needed for carriage and logs. The maximum spacing for skyline roads under these conditions should be 150 feet. Equipment needed for long span overstory removal work consists of 5,000 feet of 1- $\frac{1}{2}$ -inch skyline on a single drum, a modified high lead yarder, a heavy duty tower, and a slackpulling carriage.

Live Skyline With Remote Control Carriage (Figure 8-17)

Another system which has been used for overstory removal work is the live skyline with a remote control carriage. This system has the advantage of being able to lower the carriage into canyons to extract logs. Normally, however, the skyline is not raised and lowered during the yarding cycle unless the skidding line from the carriage cannot reach the logs. This operation is done separately from inhaul and outhaul functions and, therefore, adds to the cycle time. The corridor width for this type of system is generally 20 feet and the maximum spacing between skyline roads should be 150 to 200 feet. Yarding distance is limited by the amount of mainline that the yarder can spool.

Carriages without slackpullers cannot be used in overstory removal. The size of the timber in an overstory removal requires at least a $\frac{3}{4}$ -inch and in some cases an 1-inch mainline. This size line is very difficult for the choker-setter to pull laterally through the carriage and into the woods by hand; therefore, manual slackpulling carriages are difficult to operate. Examples of these non-slackpulling carriages are grapples, North Bend, South Bend, slackline, and flyer. The maximum width of road that can be logged with this type of carriage is 30 or 40 feet. With skyline roads spaced this close, very little residual stand will be left undamaged. Side-blocking the skyline also results in excessive damage to the residual stand.

Units for this system should be laid out for uphill yarding because the carriage runs out under gravity. If the unit boundary is to be placed on the opposite hillside, the profile should be checked to see if the carriage can slide all the way back under gravity. If a haulback line is required to pull the carriage out, another yarder-drum would be required and the outhaul time would be doubled. Rigging the system would also take longer because of the cornerblocks required for the haulback.

If the unit is laid out so that logs will have to be yarded across a creek, the profile should be checked to see that there is adequate clearance to suspend the logs free of the ground. On the other hand, the unloaded carriage must be close enough to the ground so that the tagline can be pulled out the specified lateral distance.

Running Skyline With Mechanical Slackpulling Carriage (Figure 8-18)

The running skyline system is quite versatile in that it can yard equally well uphill or downhill and can span 1,000 to 2,000 feet, depending upon the yarder. Yarders for the system are mounted either on rubber tires or on tracks. They have 37-55-foot booms and are designed to operate with either two or three skylines. Because of the yarders' mobility and swing capability, landings are not as much of a problem as with conventional type yarders. A running skyline yarder can move

STANDING SKYLINE - RADIO CONTROLLED CARRIAGE

mobile tower

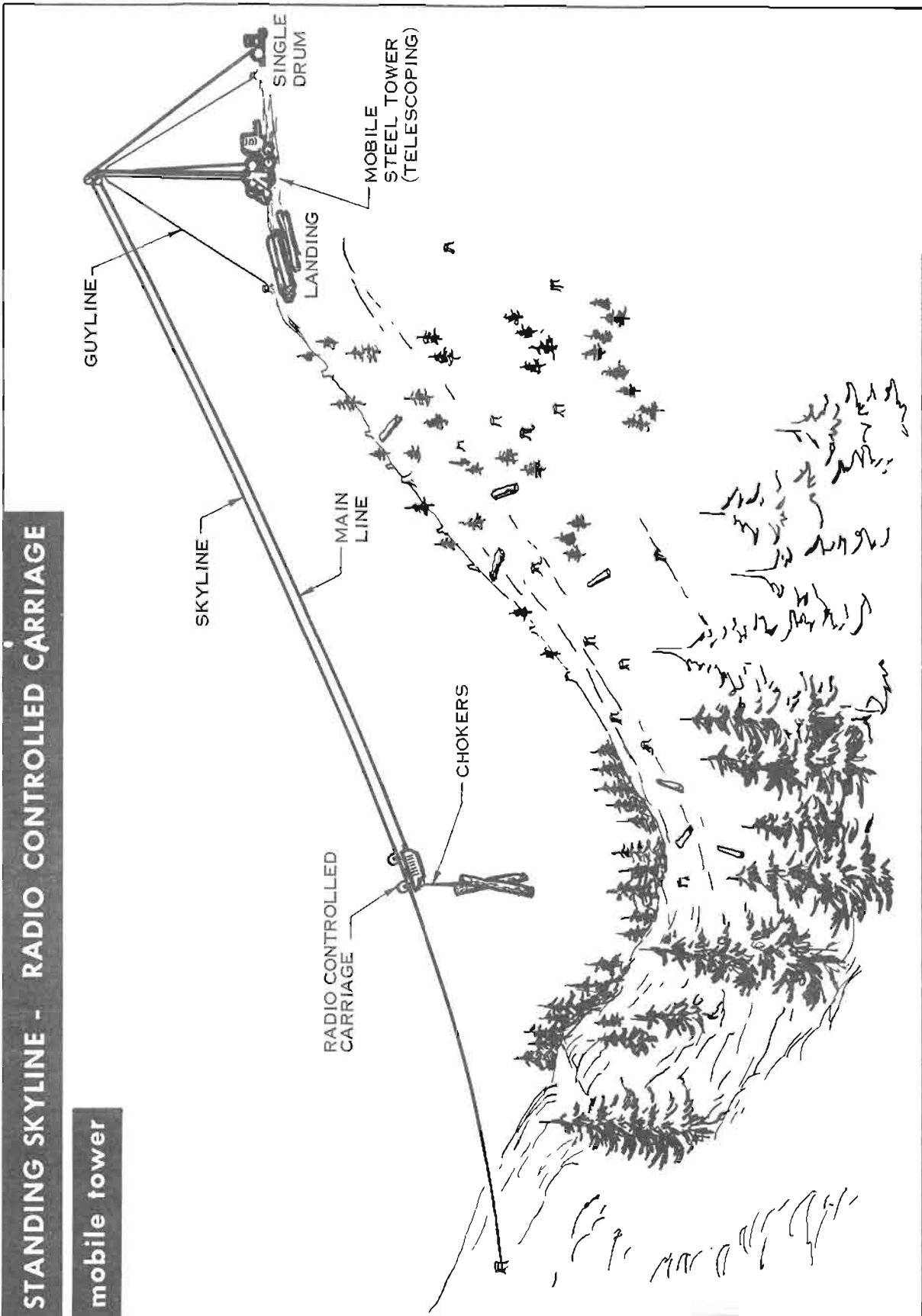

FIGURE 8-16



LIVE SKYLINE with radio controlled carriage

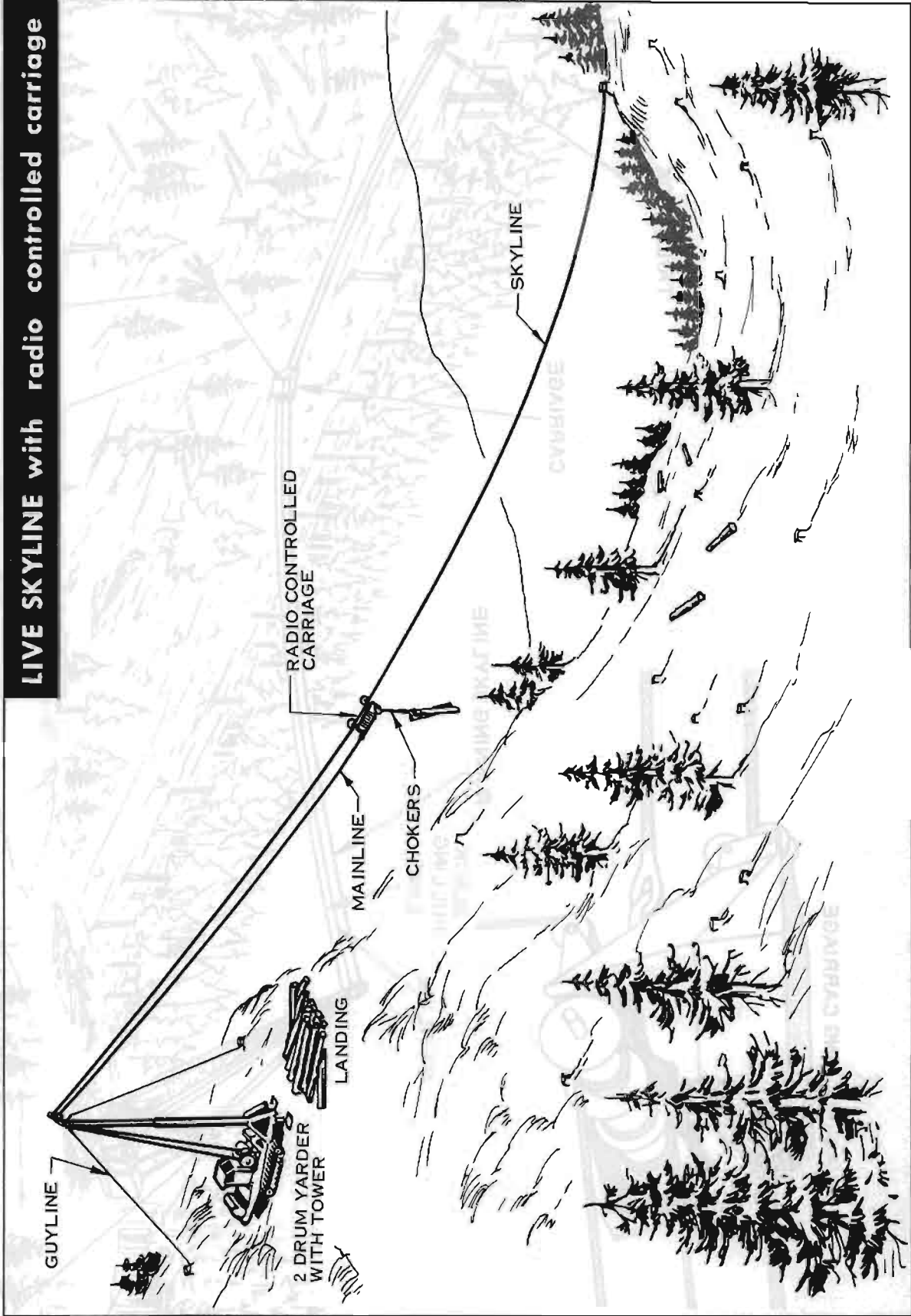

FIGURE 8-17

PARTIAL CUTTING WITH RUNNING SKYLINE

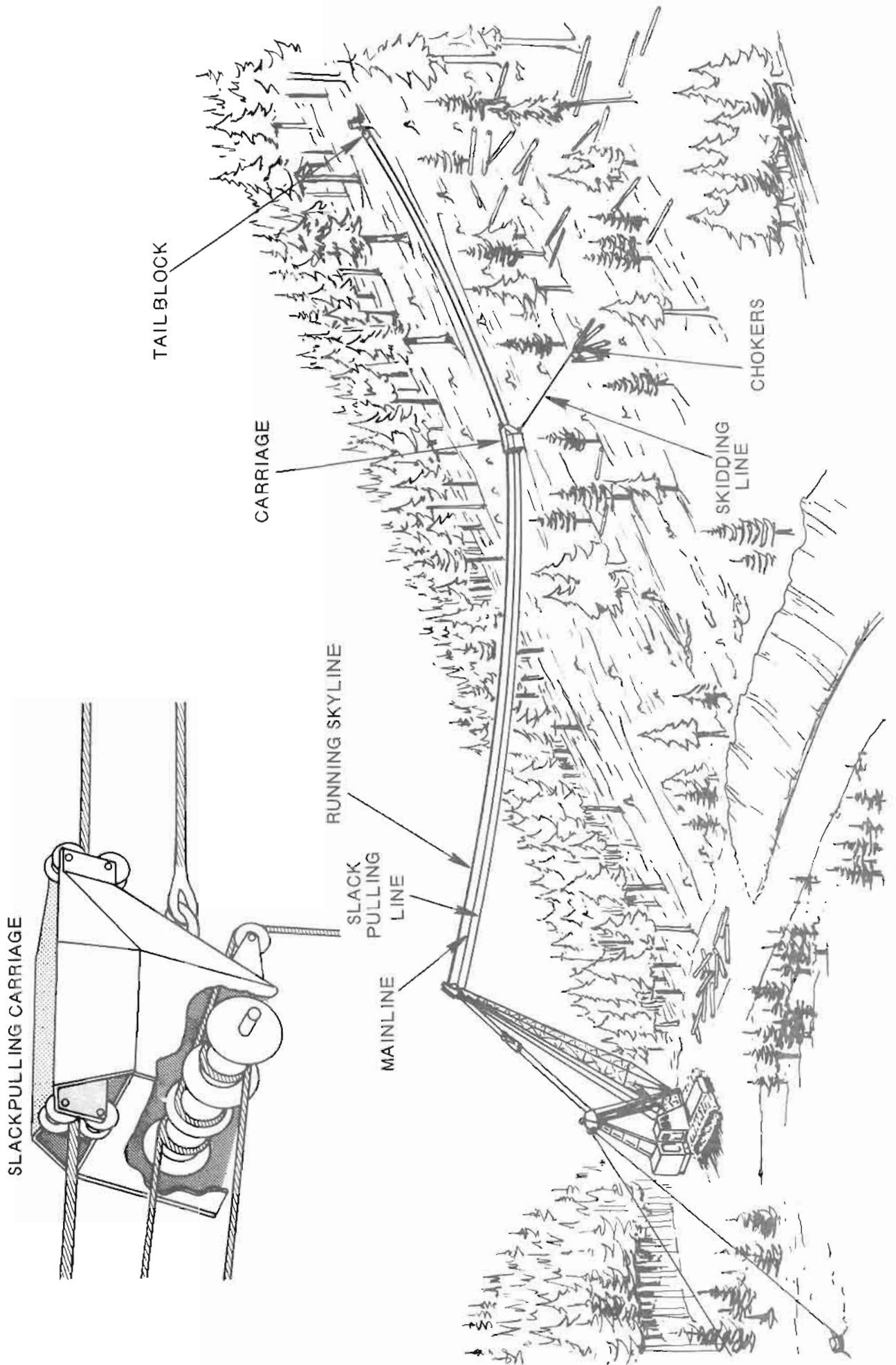

Figure 8-18

along the road, building decks beneath itself or swinging the logs onto the road alongside itself. Additional landing width should be allowed for counterweight clearance. The yarder is equipped with two mainline drums and one haulback drum. These may be interlocked.

To minimize damage to the residual stand in a partial cut, the carriage should be at least 20 feet above the ground during lateral skidding. This provides lift to the log and reduces its turning radius into the corridor. The closer the carriage to the ground, the greater the damage to the remaining stand.

Running skyline systems, like all skyline systems, must have deflection in the lines in order to operate. A minimum of 6% is needed to provide lift to the front end of the logs. If the logs are not to touch ground during yarding, there must be sufficient deflection in the lines so that they can support the load and there must be enough clearance between the carriage and the ground to allow the log to be fully suspended. Quite often, this is difficult to achieve in uphill yarding. When the turn approaches the yarder (within 200 feet), the logs begin to touch the ground because of the limited lift provided by the short towers.

In an overstory removal or partial cut, cycle times will average between five and six minutes with two logs per turn. At this rate, production will approximate 150 pieces per day. Skyline roads will be approximately 150 feet wide with the corridor widths 15 to 20 feet, depending upon the size of the material yarded. If the material is cut into 48-foot lengths, the corridors must be wider--approximately 20 to 25 feet--because of the difficulty of turning the logs into the corridor.

THINNINGS

Many of the sale layout procedures applying to overstory removal also apply to thinnings. However, thinning material is smaller. Therefore, the equipment for logging it is smaller and yarding distances generally shorter.

The yarder is usually a small mobile machine using a maximum of 1-inch skyline. It should be capable of reaching approximately 1,000 feet. Carriage requirements are the same as those for overstory removal--a slackpulling carriage or a carriage capable of having slack pulled through it. The carriage should be able to maintain a fixed position on the skyline during lateral yarding. The skyline is normally kept down in the crown of the stands.

Live Skyline--Mobile Yarders (Figure 8-19)

Mobile yarders used in thinning operations are double-drum cranes or track loaders modified for yarding. Most of these can yard 800 to 1,000 feet with a maximum skyline diameter of 1 inch. A hand-operated hydraulic clamping carriage is commonly used with this yarder. The carriage clamps to the skyline during the lateral yarding operation and the mainline is pulled through the carriage by the choker setters. This necessitates lowering the carriage to the choker setters and raising it again before lateral skidding. When the hook contacts the carriage, the clamp is released and the load is locked into the carriage.

Rigging this type of system is fairly simple. Road changes usually take 30 to 45 minutes, while landing changes require about an hour. If adequate deflection does not exist, a tailtree may have to be rigged. This will require hanging a

LIVE SKYLINE with mechanical carriage

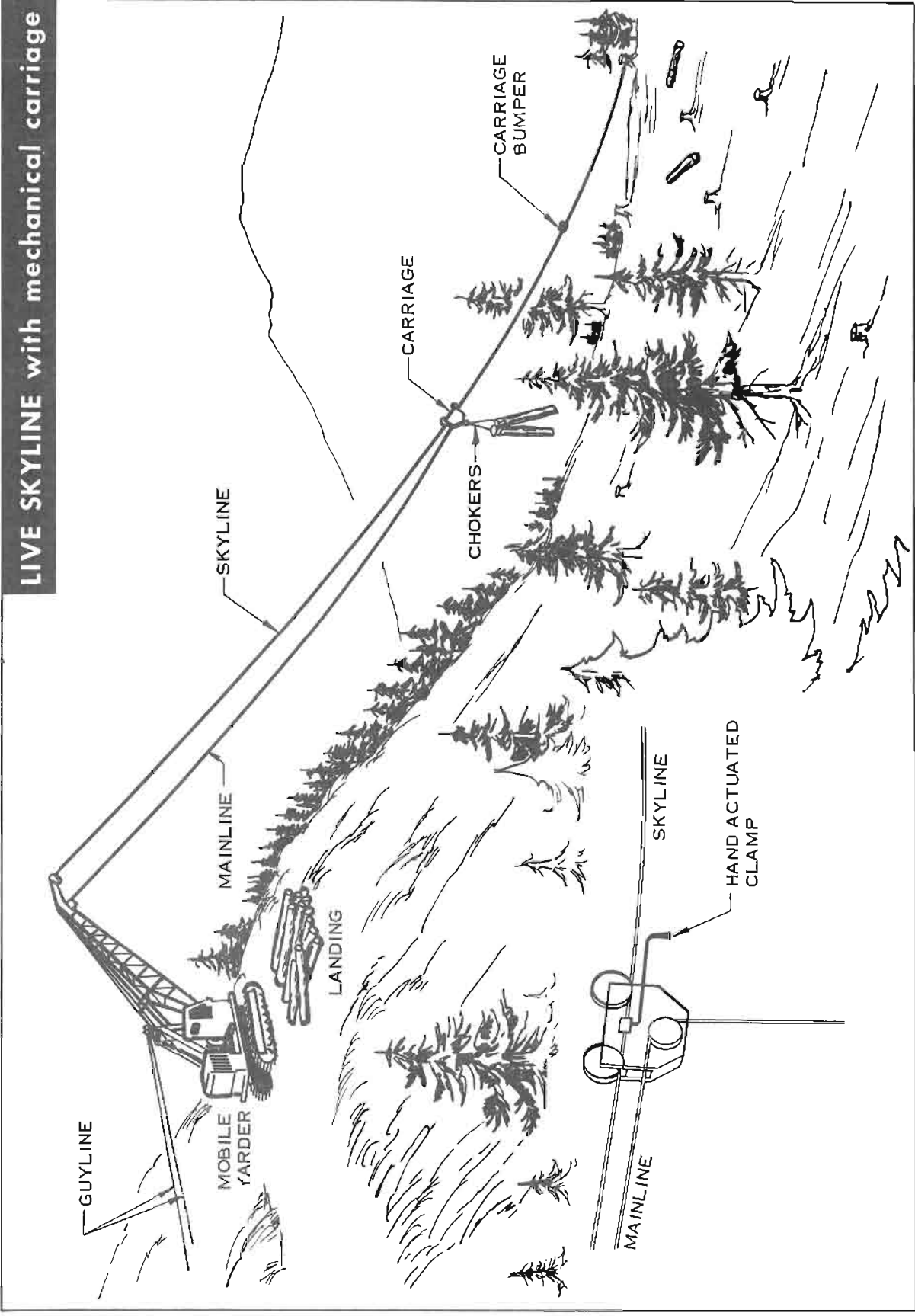

FIGURE 8-19



SIDE MOUNT TOWER with mechanical slack pulling carriage

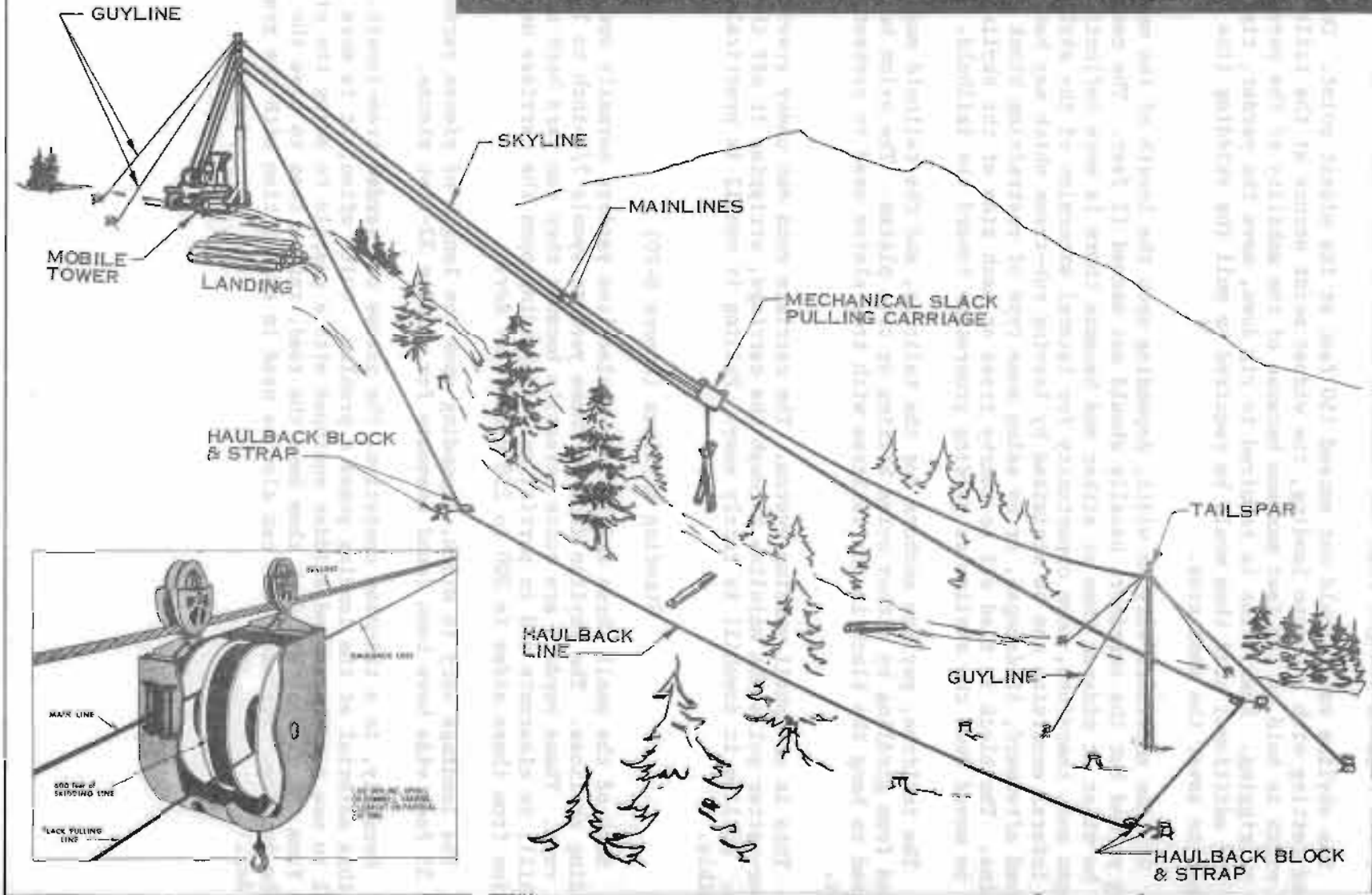

FIGURE 8-20
COL

a tailblock and guying the tree back with two guylines (Ref: State Safety Codes). Usually the rigging-slinger rigs the tailtree ahead of the road change.

The skyline road should not exceed 150 feet at its widest point. On a fan-shaped setting with a common landing, the widest point occurs at the tailhold. The road width is held to 150 feet maximum because of the mobility of the yarder and ease of rigging. Less time is required to rig down, move the yarder, rig up, and yard the additional road than would be required to pull the skidding line the extra 75 feet to cover the same area.

Skyline corridors vary in width, depending upon the length of the material being yarded but the corridors usually should not exceed 12 feet. The corridors will be wider at midspan than at either end because there is more deflection at midspan and, therefore, more opportunity for lateral excursion of the skyline. This lateral excursion can be minimized by leaving rub-trees which may have to be removed afterward, if damaged, or by using some type of restraining block on the skyline. The block is tied off to nearby trees on each side of the skyline and must be moved down the skyline as yarding progresses toward the tailhold.

The tailtree, guyline anchors for the tailtree, and the tailhold may be protected from girdling by either nylon belting or tree plates. The nylon belting can be used to hang the block in the tailtree with tree plates used to protect anchor trees.

This is an uphill yarding system. The carriage runs out under gravity. The choker-setter pulls the mainline through the carriage, stripping it off the yarder drum. Pulling it downhill is fairly easy. Pulling it uphill is practically impossible.

Standing Skylines (Figure 8-20)

Most of the small three and four-drum slackline yarders normally operate as standing skylines. The skyline drum on these yarders spools 7/8-inch to 1-1/8-inch wire rope. These yarders are quite versatile because they can yard both uphill and downhill, in clearcuts and in partial cuts, depending upon the carriage used. Production from these sides is 200 to 250 pieces per day.

The landings vary in width, depending upon the length of pieces yarded. Landings 35 feet wide have been found adequate for yarding 32-foot pieces.

Normally, in a thinning operation, the pieces are yarded tree-length. Holding this material at the landing poses a problem. Quite often, it is more economical to use a rubber-tired skidder equipped with a grapple to swing the pieces away from the landing and deck them down the road, rather than to have the loader at the landing. Preload bunks can also be used in conjunction with the grapple skidder.

CHAPTER 9 DESCRIPTION OF CABLE LOGGING SYSTEMS

A brief description of the various rigging configurations for the different cable logging systems are presented in this chapter. A description of each is accompanied by an illustration of that cable system. It would be impossible to show all of the cable systems that have been used. Most are variations of a basic rigging configuration. Therefore, only the basic or more common cable systems are described, beginning with the relatively simple single-drum jammer with tongs, and progressing to the more sophisticated running skyline and baloon systems.

This chapter also presents a list of yarders with line sizes and capacities, a description of towers and undercarriages, and a listing of carriages and their capabilities.



FIGURE 9-1

SHOVEL LOADER JAMMER (Figure 9-1)

Yarding direction: Uphill

Cutting prescription: Clearcut or partial cut

Maximum yarding distance: 100 to 300 feet

Yarder description: A single drum mobile loader used for yarding with 5/8-inch to 3/4-inch skidding line.

Tower and undercarriage description: The tower is usually a heelboom or lattice boom, 15 to 25 feet in length. The undercarriage is either rubber tired or tracked.

Carriage description: Tongs

Crew size: 2 men; yarder operator and tongsetter

Average production: 80 to 120 pieces per day

System direction: A 10 to 12 foot wide road is needed to move and operate the yarder. Road spacing is 200 to 300 feet. After the logs are yarded to the road and deck, the yarder loads trucks.

Operational characteristics: There are three methods of delivering the tongs to the tongsetter:

1. The tongsetter can pull the line from the yarder out to the log. A mechanical slackpuller may be mounted on the boom to aid in pulling slack.
2. The tongs can be "thrown" out by swinging the boom back and forth and releasing the brake on the skidding line drum at precisely the right moment.
3. A tight line can be rigged between the yarder and a stump. The tongs are then slid down the line to the tongsetter. This is sometimes referred to as "clotheslining".



JAMMER WITH WOOD BOOM

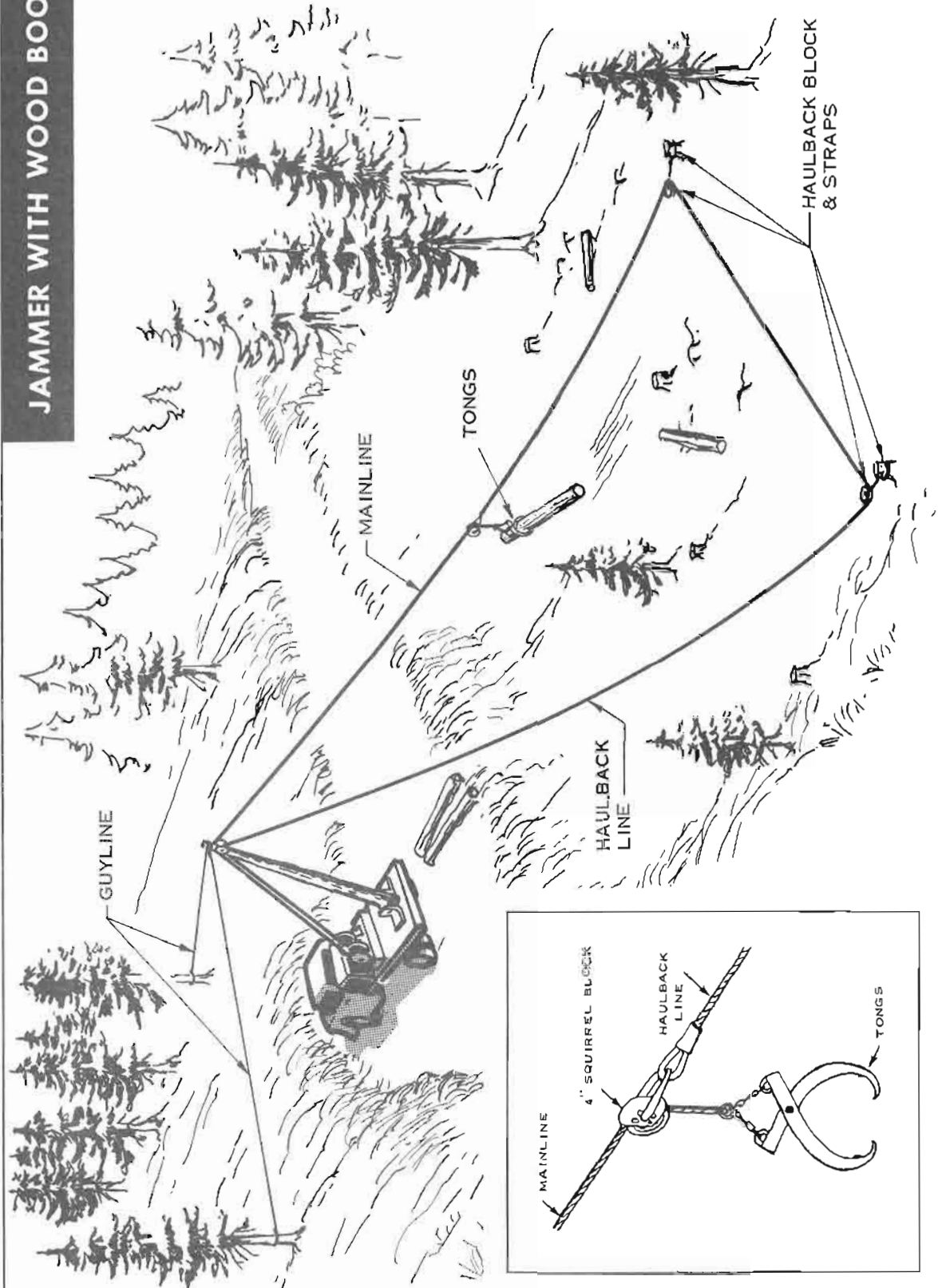

FIGURE 9-2

JAMMER WITH WOOD BOOM (Figure 9-2)

Yarding direction: Uphill

Cutting prescription: Clearcut

Maximum yarding distance: 300 to 700 feet

Yarder description: A two-drum yarder with 1/2-inch to 9/16-inch mainline and 1/2 -inch haulback line.

Tower and undercarriage description: A steel lattice tower or wood spar is mounted on a truck or tractor undercarriage. These are usually shop-fabricated. Two or three guylines are used.

Crew size: 2 men; yarder operator and tongsetter

Average Production: 120 to 200 pieces per day

System description: The yarder requires a 10 to 12-foot wide road to operate. Road spacing is 300 to 500 feet. The butt-rigging or tongs is pulled to the brush with the haulback line. After the logs are attached they are pulled to the landing with the mainline. With tongs, the lateral yarding distance is approximately 30 feet.

Operational characteristics: The yarders cannot brake the haulback drum to tightline the turn; therefore, the logs are ground led to the landing. This system is not recommended for partial cuts. If the lateral yarding distance exceeds 30 feet, the lateral excursion of the lines will damage the residual stand. This system normally operates in a square lead and builds a continuous log deck below the road.

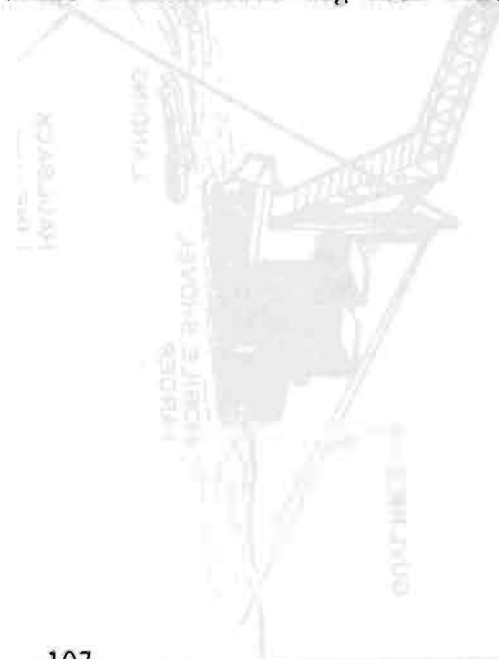

MOBILE SHOVEL YARDER

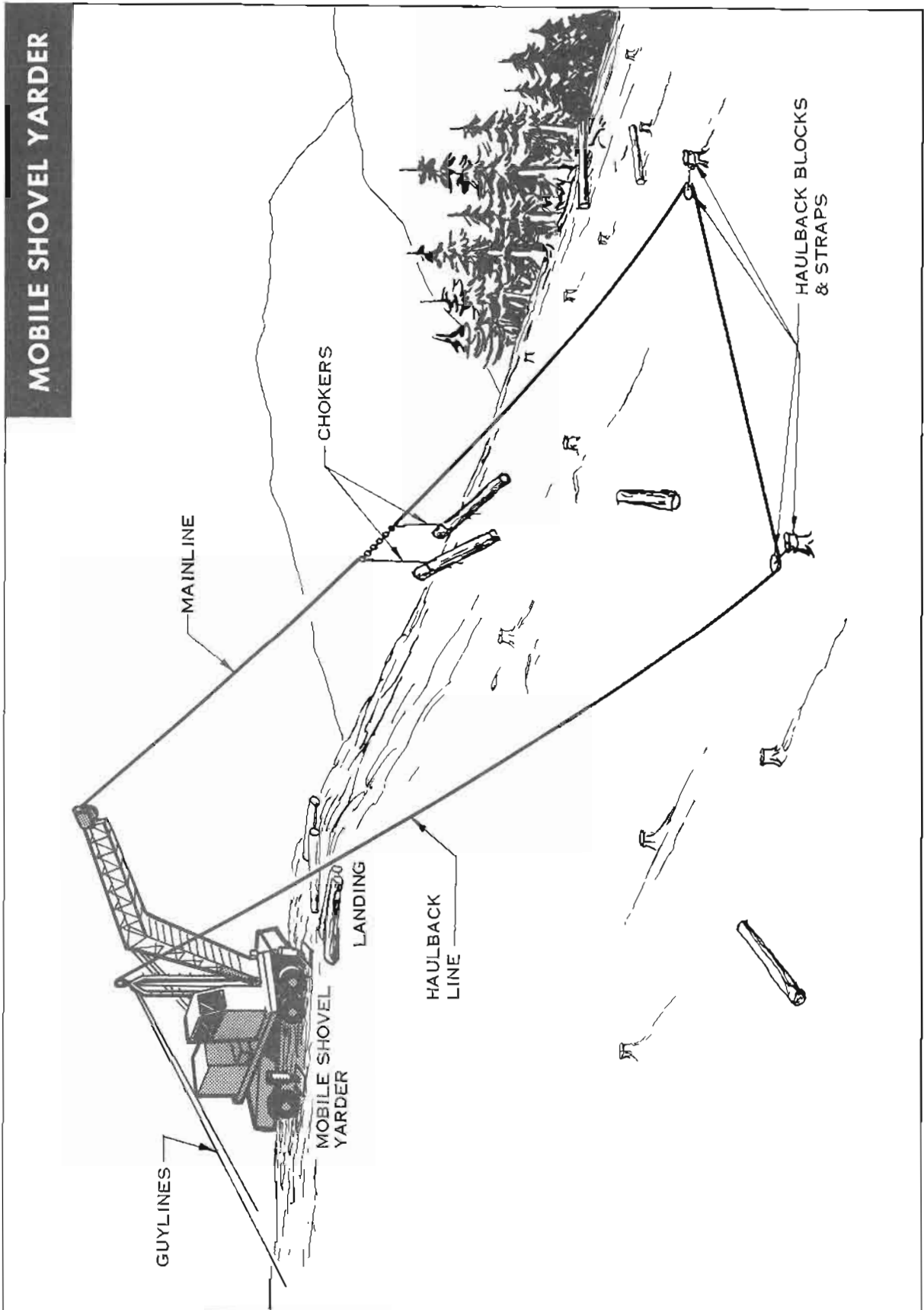

FIGURE 9-3



MOBILE SHOVEL YARDER (Figure 9-3)

Yarding direction: Uphill

Cutting prescription: Clearcut

Maximum yarding distance: 500 to 700 feet

Yarder description: A two-drum yarder with 5/8-inch to 1-inch main line and 1/2-inch to 3/4-inch haulback line.

Tower and undercarriage description: The tower is a straight lattice boom or a heelboom which, with the drum set is mounted on a turntable. The undercarriage may be rubber tired or tracked. Two guys are used.

Carriage description: Butt rigging with chokers, tongs, or a McAllister Block.

Crew size: 3 or 4 men

Average production: 80 to 150 pieces per day

System description: The butt rigging and chokers are returned to the woods by the haulback line. Once the logs are attached, the mainline ground-leads the turn to the landing. Logs may be decked below the road or landed on the road.

Operational characteristics: The haulback line may be used as a clothesline on which the tong or McAllister block rides back to the woods. The haulback line does not support any of the load. The swing of the boom provides some control of the turn as it approaches the landing and in decking.

HIGHLEAD

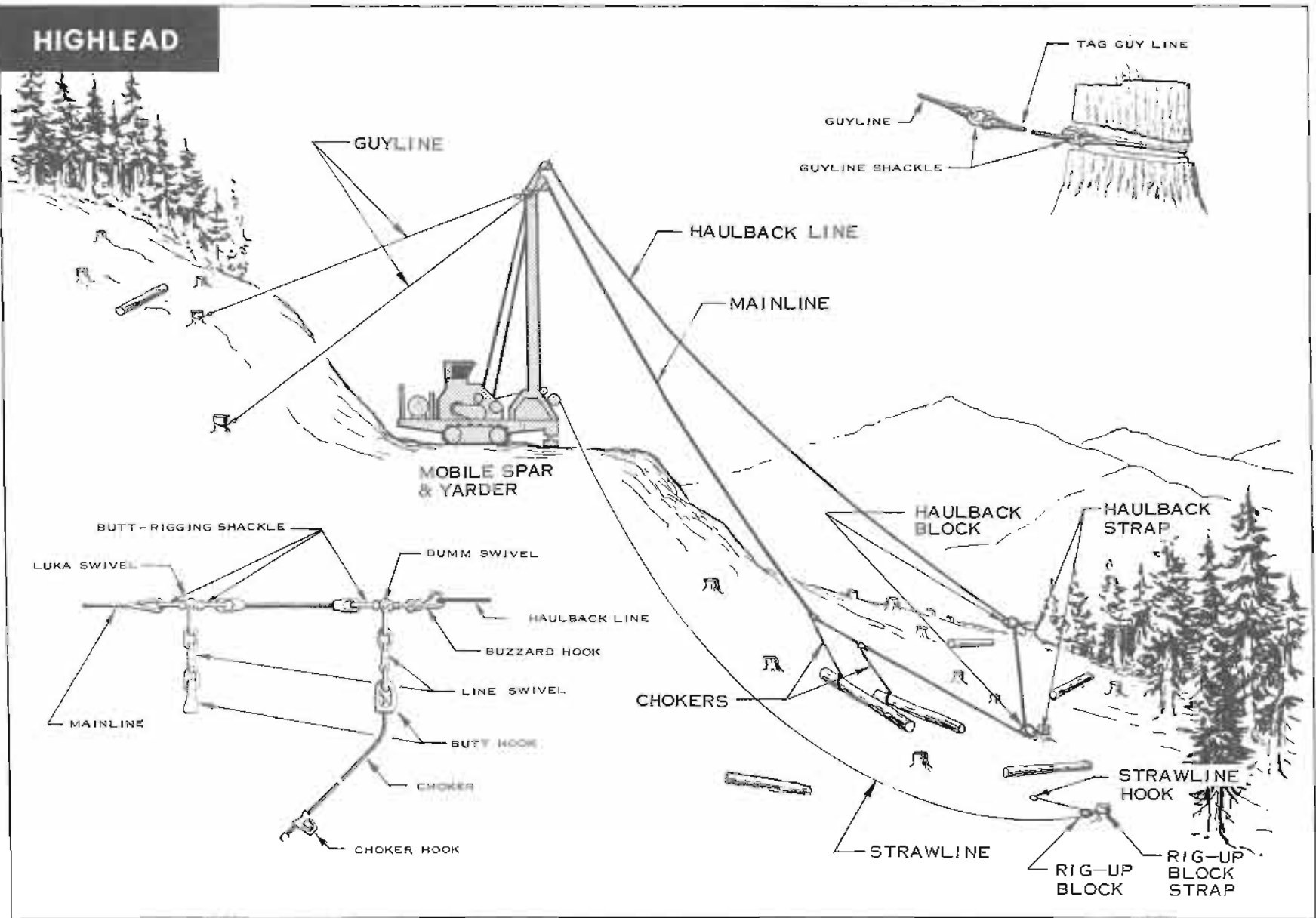

Figure 9-4

HIGHLEAD (Figure 9-4)

Yarding direction: Uphill or downhill

Cutting prescription: Clearcut

Maximum yarding distance: 1,000 feet up, 600 feet down

Yarder description: Main and haulback drums. Mainlines range in size from 3/4-inch to 1-1/2-inch. Haulback drum should have sufficient brake capacity to tightline a turn.

Tower and undercarriage description: Towers range in height from 28 feet to 110 feet. The taller towers are usually telescoping with 6 guylines. The undercarriage may be tracked or rubber mounted and self-propelled, or trailer mounted. The yarder may also be mounted on a sled.

Carriage description: Butt-rigging with chokers.

Crew size: 4 or 5 men; Yarder engineer, chaser, rigging slinger and choker setters.

Average production: 50 to 100 pieces per day

System description: The butt-rigging is hauled back to the woods with the haulback line. The chokers are attached to the logs. The logs are yarded to the landing with the mainline where they are unhooked. Lift is not provided to the log until it is approximately three times the height of the spar from the landing.

Operational characteristics: Lateral yarding is limited by the length of the chokers. Fire hazard is great because the haulback line is on the ground and line speeds are great.

LIVE SKYLINE with mechanical carriage

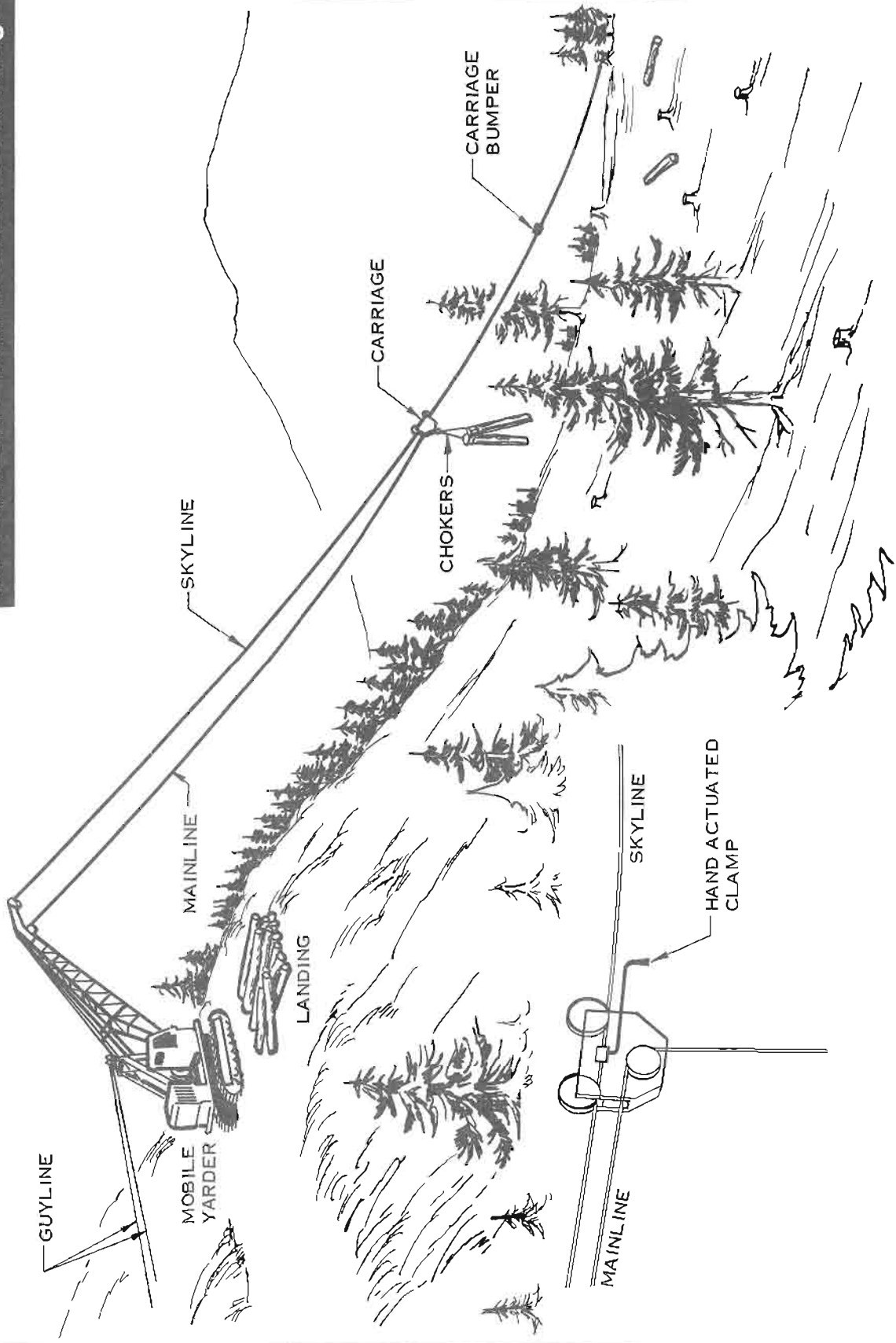

Figure 9-5



LIVE SKYLINE with Mechanical Carriage (Figure 9-5)

Yarding direction: Uphill

Cutting prescription: Thinning

Maximum yarding distance: 1,000 feet

Yarder description: A two-drum mobile yarder with the capability of reaching 1,000 feet with 5/8-inch skyline and 1/2-inch to 5/8-inch mainline.

Tower and undercarriage description: Usually a 40 foot to 70 foot stiff boom is used with a gantry. Two live guys from the gantry or one guy from the top of the tower is used. The undercarriage may be rubber or track and usually has a turntable. The tower may have a slackpuller mounted on it.

Carriage description: The carriage has a hand operated hydraulic clamp holding it to the skyline. Slack is pulled through by hand. A locking device on the carriage holds the mainline during inhaul.

Crew size: 4 men

Average production: 150 to 275 pieces per day

System description: The carriage is returned under gravity. The skyline must be lowered to allow the choker setter to release the mainline and clamp the carriage. Slack is pulled by hand. The carriage is raised up before lateral yarding. When a knob on the mainline contacts the carriage, the clamp is released.

Operational characteristics: Small lines are used; therefore, rigging is relatively easy. There are no running lines other than the mainline which is suspended. Nylon straps may be used to protect the tailtree. Lateral yarding distance is 75 feet. Chokers may be pre-set.

LIVE SKYLINE - shotgun or flyer system

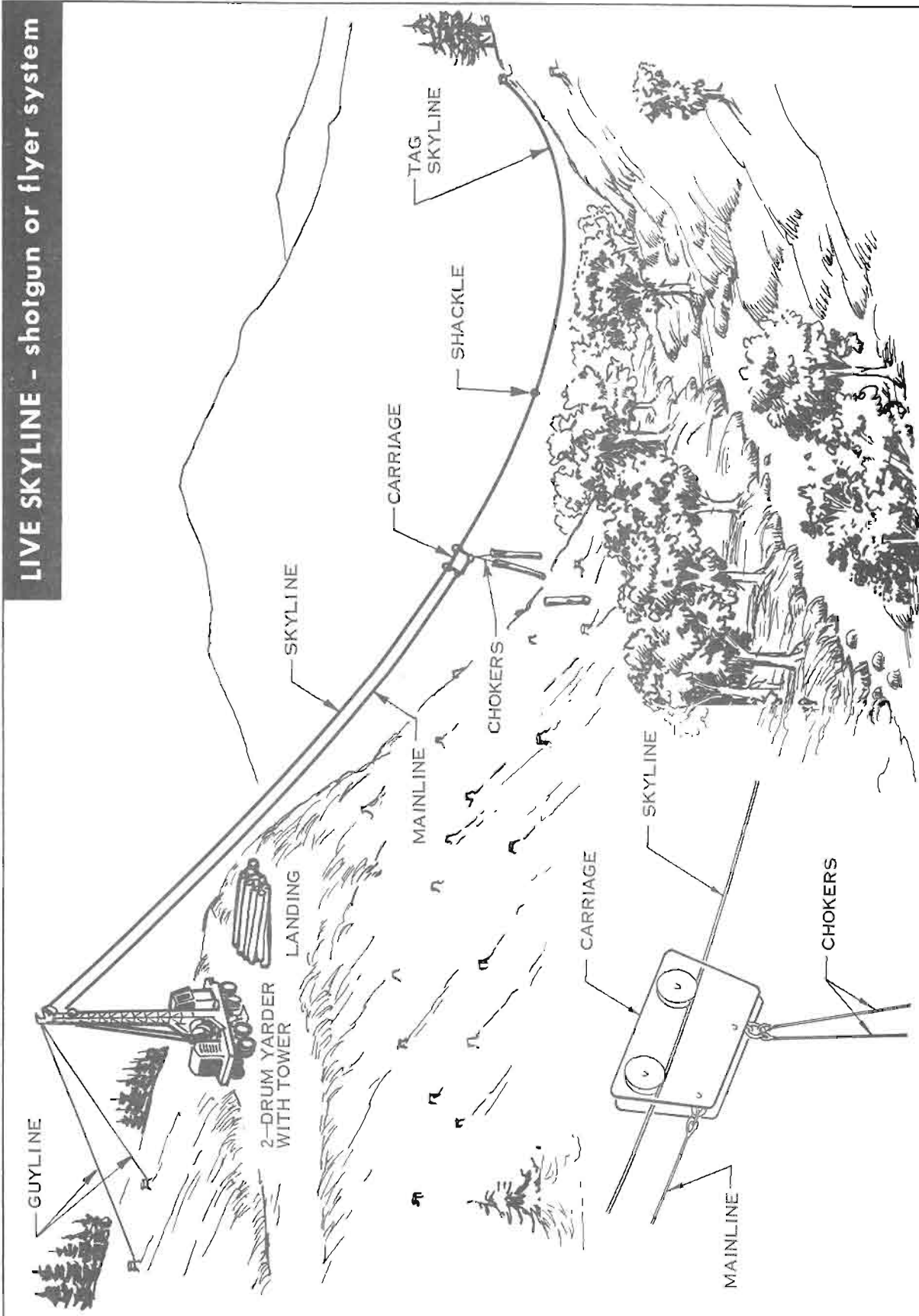

Figure 9-6



LIVE SKYLINE, Shotgun or Flyer System (Figure 9-6)

Yarding direction: Uphill

Cutting prescription: Clearcut

Maximum yarding distance: 1,500 to 2,000 feet

Yarder description: A highlead yarder can be converted to the shotgun system by 1) Using the mainline as the skyline and 2) Using the haulback line as the mainline. The yarder should have sufficient line speeds and power to lift the turn of logs and move them to the landing at speeds of 1,000 feet per minute. Skyline brakes must be capable of holding a turn fully suspended.

Tower and undercarriage description: Standard highlead towers and under-carriages are used. The tower may be modified by placing an additional fairlead beneath the mainline fairlead. The haulback line is re-strung through the lower fairlead and becomes the mainline or inhaul line for the shotgun system.

Carriage description: A shotgun carriage weighs 900 to 2,300 lbs. It consists of two skyline sheaves with weighted sideplates. Chokers are attached to the bottom of the carriage. Lateral yarding is obtained by using long chokers (70 feet).

Crew size: 5 or 7 men

Production: 100 to 150 pieces per day

System description: The carriage moves down the skyline by gravity to the point of loading. It is lowered to the ground to allow the logs to be choked. The carriage is raised by the skyline and brought to the landing by the mainline. A tag skyline may be shackled on to gain extra distance. However, a carriage with wide throat sheaves must be used to pass over the shackle.

Operational characteristics: This system has many advantages over the highlead.

1. Fire hazard is reduced because the haulback line is eliminated.
2. Choker setters are not working in the bight of a line.
3. Lighter chokers are used because less hang-ups are encountered.
4. Cycle times are faster, due to less hang-ups and faster line speeds.
5. There is less log breakage during yarding.
6. Soil disturbance is minimized.

SLACK LINE SYSTEM

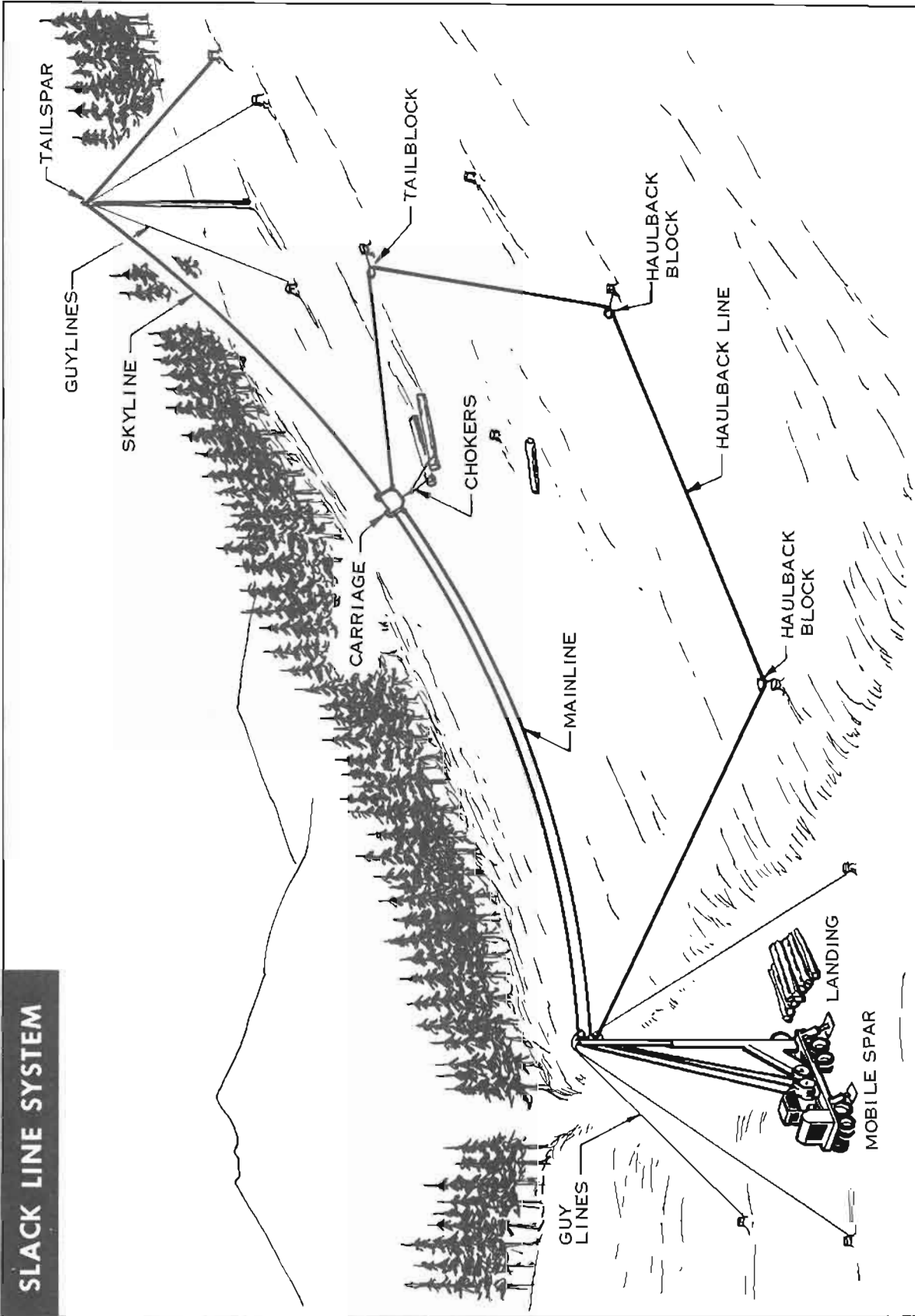

FIGURE 9-7

SLACKLINE SYSTEM (Figure 9-7)

Yarding direction: Uphill or downhill

Cutting prescription: Clearcut

Maximum yarding distance: 2,000 to 2,500 feet up, 1,000 feet down.

Yarder description: Three drums: haulback, main and skyline. Skyline size ranges from 1-inch to 1-1/2-inch diameter. Capacity ranges from 1,500 feet to 2,500 feet. Some highlead yarders provide for adding a third drum.

Tower and undercarriage description: Towers are 45 feet to 120 feet tall. The taller towers are heavy duty with either 7 or 8 guylines. Undercarriage may be self-propelled track or rubber, or may be a trailer.

Carriage description: A block carriage, similar to the shotgun carriage is used.

Crew size: 5 men

Average production: 100 to 150 pieces per day

System description: The carriage is pulled out by the haulback line. The skyline has to be lowered to allow the logs to be choked to the carriage. The skyline is raised and the turn is brought to the landing with the mainline.

Operational characteristics: Some lateral capability may be obtained by setting the tailblock to the side, thus pulling the carriage off to the side. The skyline has to be slacked at the same time. Rigging is difficult because of the haulback line. Fire and safety hazard is increased.

LIVE SKYLINE with radio controlled carriage

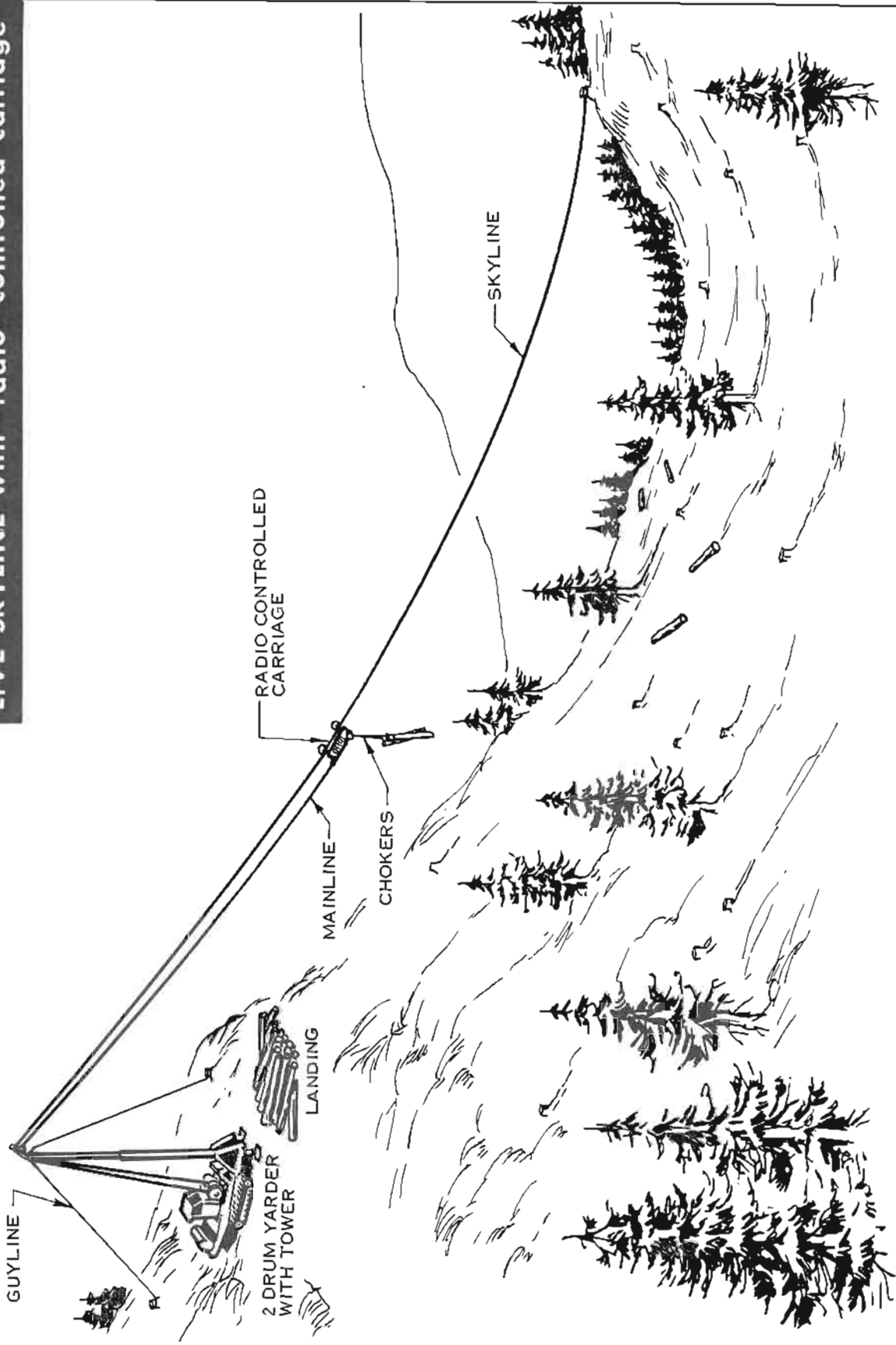

Figure 9-8



LIVE SKYLINE With Radio-Controlled Carriage (Figure 9-8)

Yarding direction: Uphill

Cutting prescription: Clearcut, partial cut, thinnings.

Maximum yarding distance: 1,500 to 2,000 feet

Yarder description: A two drum highlead yarder with adequate brakes on the main drum to hold a carriage and turn of logs in the air.

Tower and undercarriage description: The tower height is usually 90 feet to 120 feet with 6 to 8 guylines. The undercarriage is self-propelled rubber tire or track, or a trailer.

Carriage description: The carriages are usually remote-controlled by radios and contain a power plant either driving a skidding drum or a slackpulling device that pulls the mainline through the carriage. The carriages also have hydraulic clamps to hold them in place during the lateral yarding operation.

Crew size: 5 to 7 men

Average production: 100 to 150 pieces per day

System description: The carriage is returned to the woods under gravity, clamped to the skyline by radio signal, and the skidding line is played out. If the mainline passes through the carriage and becomes the skidding line, the yarder pulls the logs to the carriage, the clamp is released, and the carriage is brought to the landing.

Operational characteristics: If the carriage does not contain enough skidding line to reach the logs, it is possible with the live skyline to lower the carriage; however, this operation will increase the cycle time. Most yarders have insufficient power to raise the skyline and bring in the turn of logs simultaneously.

LIVE SKYLINE with radio controlled grapple

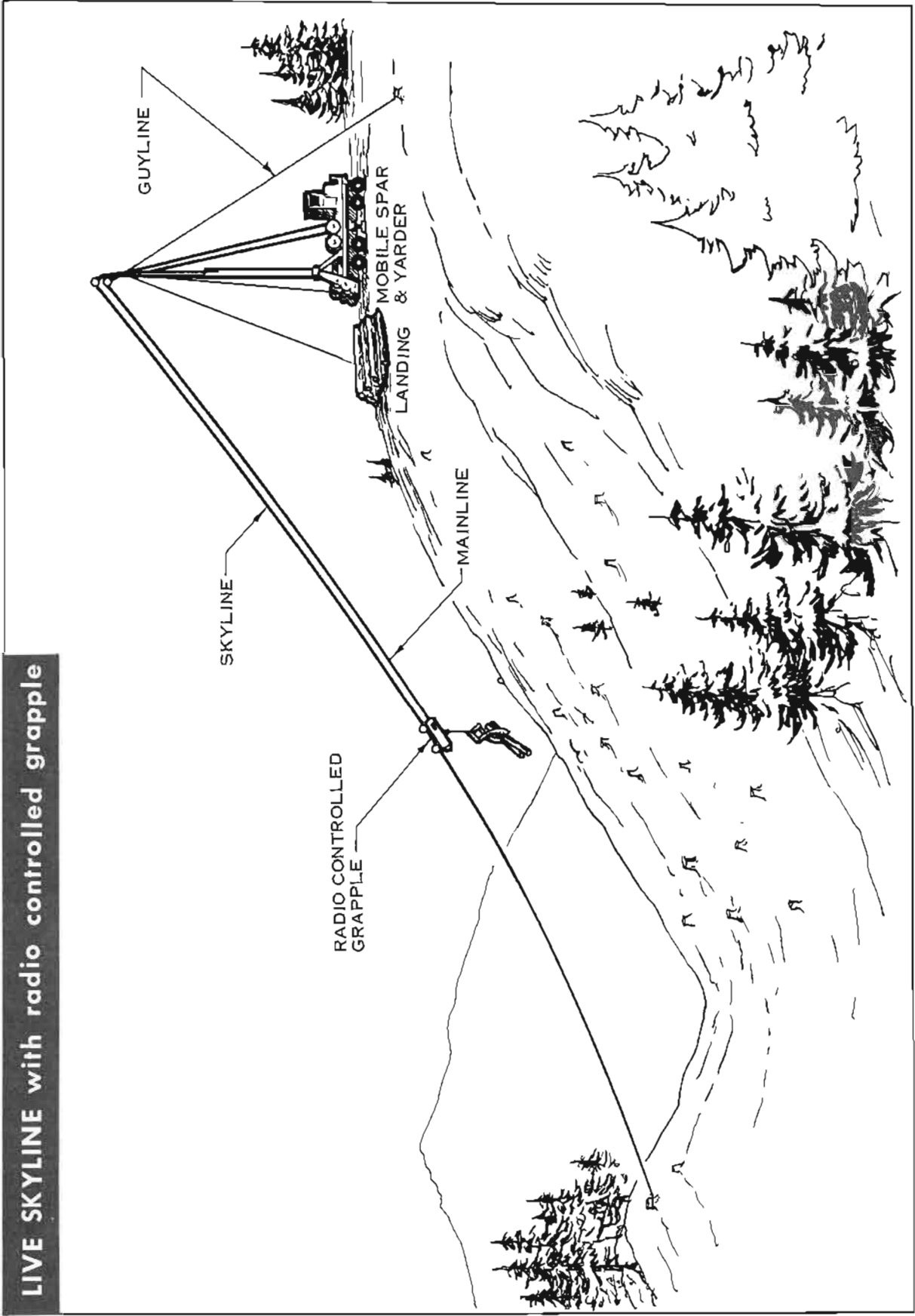

FIGURE 9-9

U S G O V E R N M E N T P R I N T I N G O F F I C E

LIVE SKYLINE With Radio-Controlled Grapple (Figure 9-9)

Yarding direction: Uphill

Cutting prescription: Clearcut

Maximum yarding distance: 1,500 to 2,000 feet

Yarder description: Same as previous system

Tower and undercarriage description: Same as previous system

Carriage description: A grapple carriage with a radio-controlled power source operating the grapple.

Crew size: 3 men; yarder engineer, spotter and rigger

Average production: 75 to 150 pieces per day

System description: The carriage is returned to the woods by gravity. The carriage is lowered over the log and the grapple is closed. The skyline picks up the carriage and log, and the mainline brings them to the landing.

Operational characteristics: There is no lateral capability. Only the logs directly under the carriage are picked up. Therefore, tree felling perpendicular to the skyline is important. A choker is usually attached to the carriage for the "hard to get" logs. Skyline roads must be rigged every 30 or 40 feet.

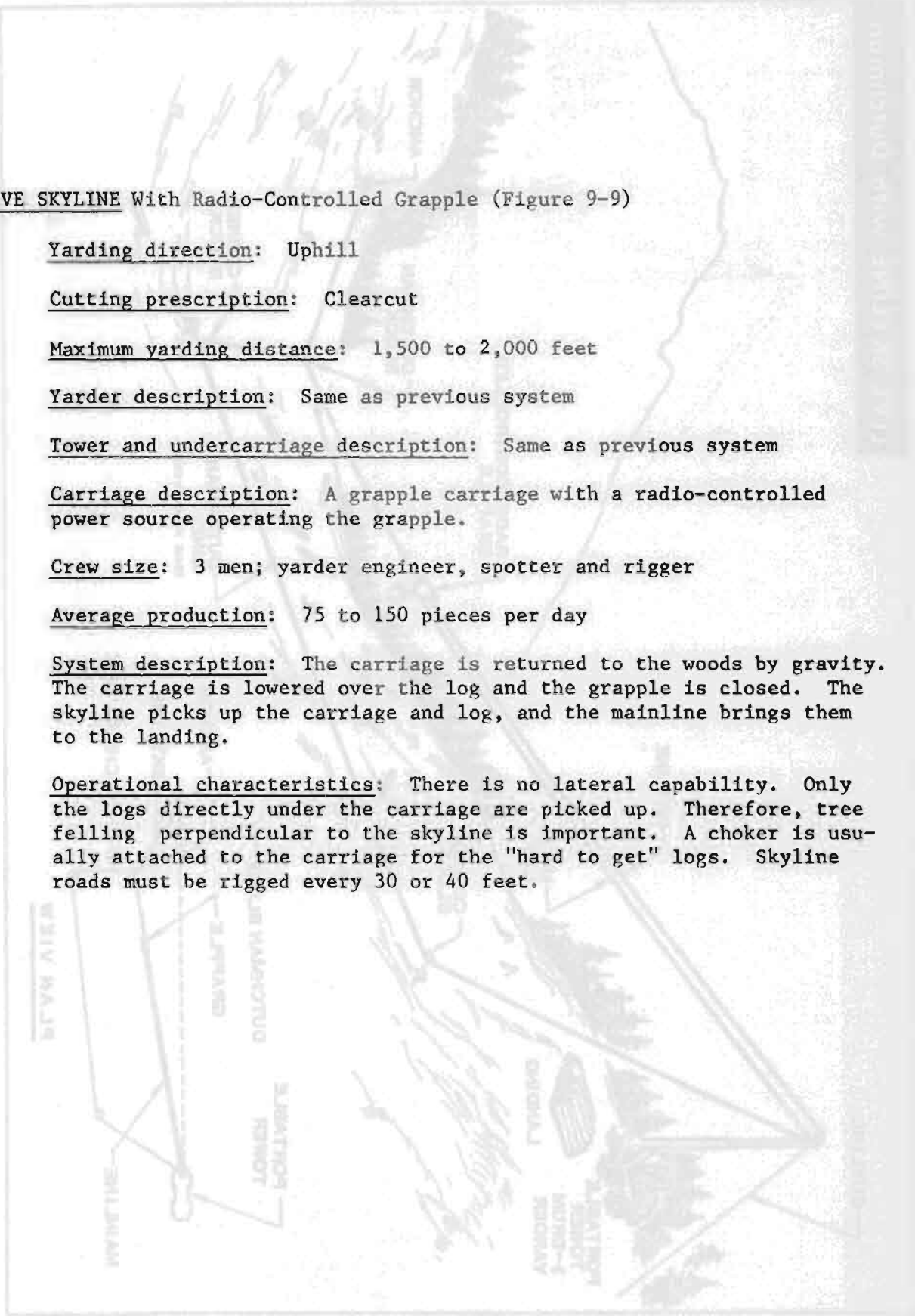

LIVE SKYLINE with Dutchman

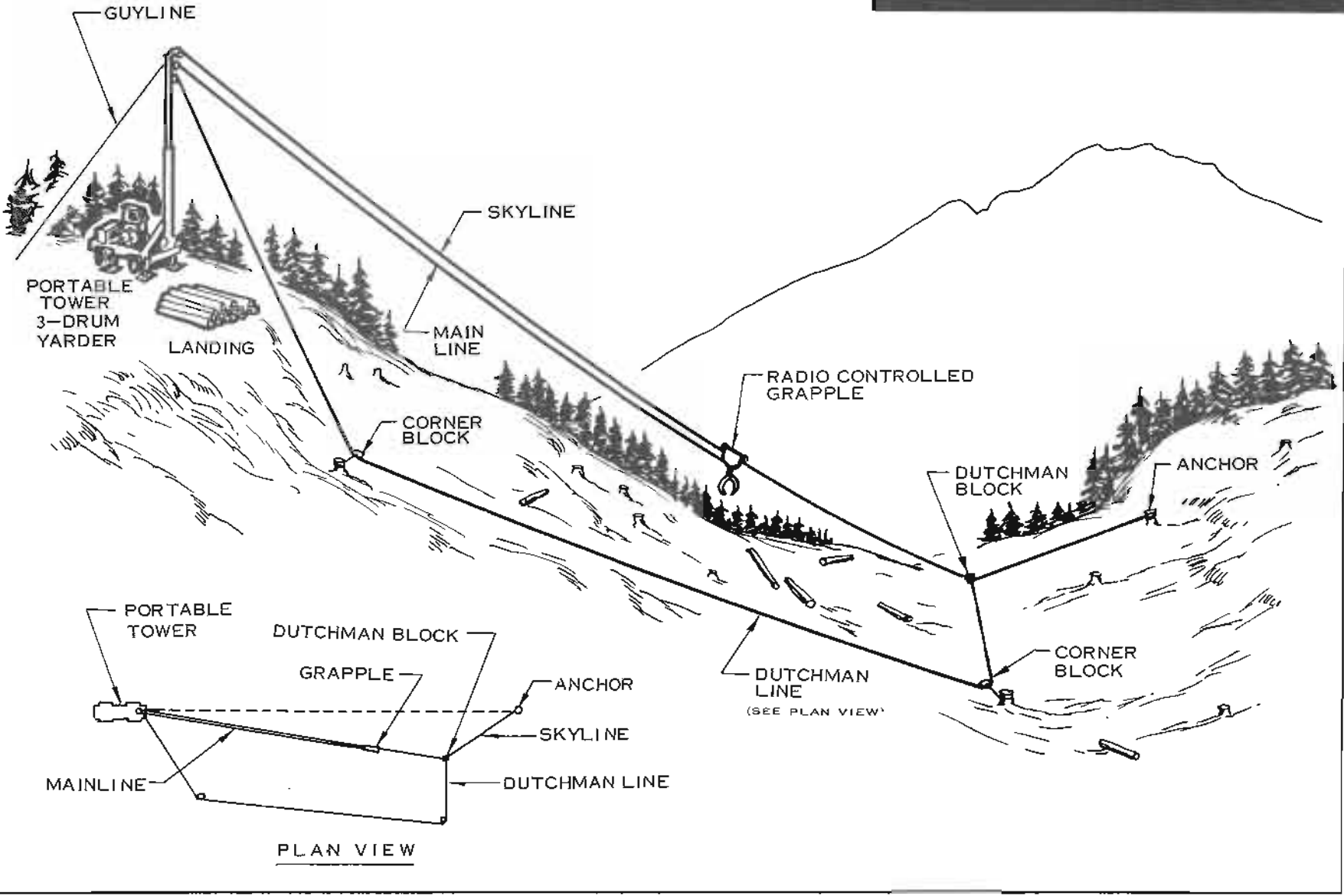

Figure 9-10

LIVE SKYLINE With Dutchman (Figure 9-10)

Yarding direction: Uphill

Cutting prescription: Clearcut

Maximum yarding distance: 1,500 to 2,000 feet

Yarder description: A slackline or three-drum yarder is needed to provide the extra line for sideblocking.

Tower and undercarriage description: Same as slackline systems

Carriage description: Does not have lateral capability such as a shotgun or grapple carriage.

System description: After the carriage is sent out, the skyline is concurrently slacked and pulled to the side with the dutchman line. After the logs have been hooked, the skyline is tensioned and at the same time, the dutchman line is slacked. The turn is yarded in after the skyline has reached its normal position.

Operational characteristics: The dutchman is used with a live skyline to facilitate hooking logs. The dutchman line should be at least the same size as the skyline. The tension in the dutchman line can equal or exceed the skyline tension.



SIDE MOUNT TOWER with mechanical slack pulling carriage

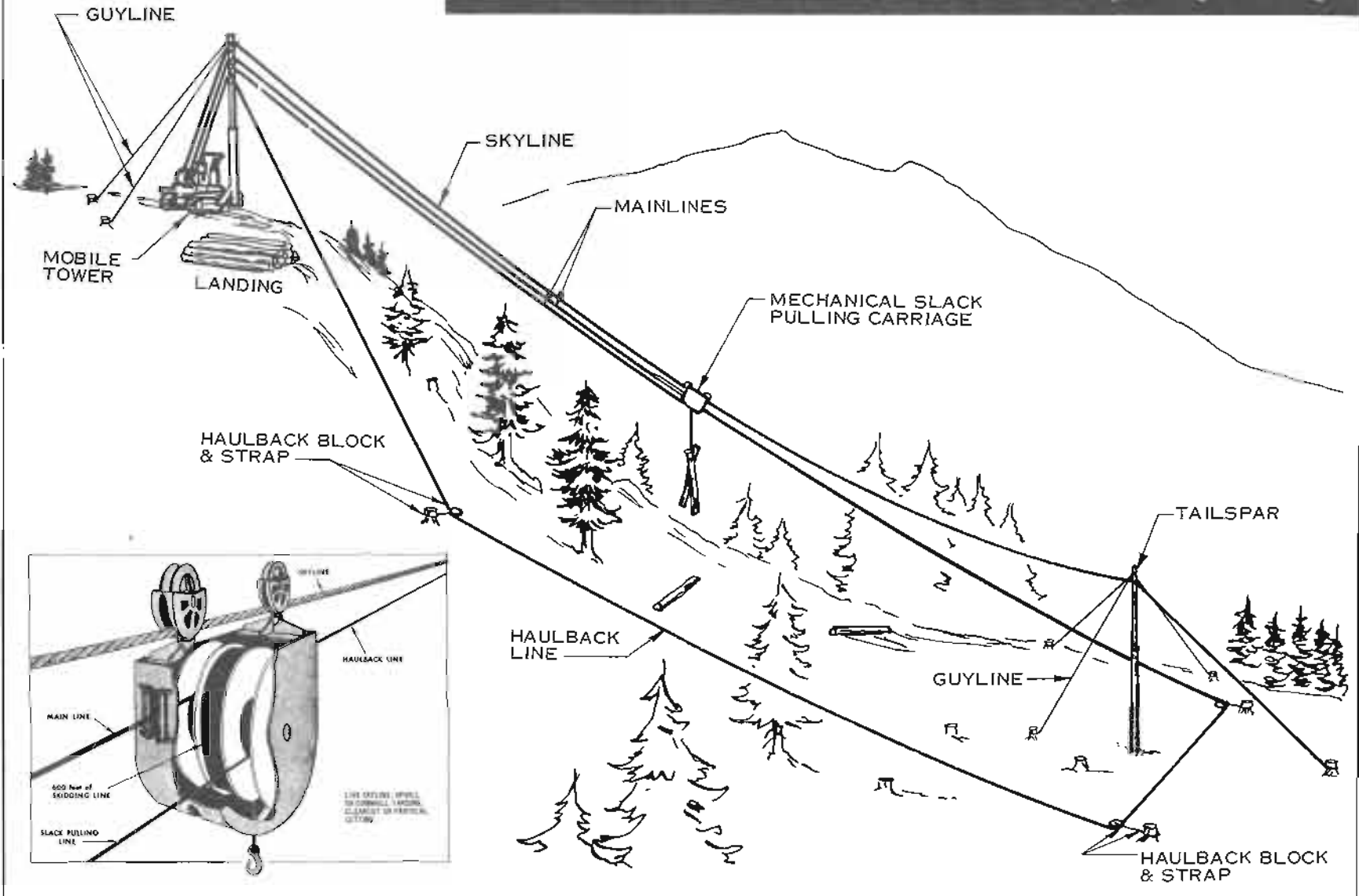

Figure 9-11

SIDE MOUNT TOWER With Mechanical Slackpulling Carriage (Figure 9-11)

Yarding direction: Uphill or downhill

Cutting prescription: Partial cut or thinnings

Maximum yarding distance: 1,000 feet uphill, 500 feet downhill

Yarder description: Four-drum yarder capable of yarding 1,000 feet with 1-1/8-inch skyline.

Tower and undercarriage description: A 50-foot telescoping tower is mounted on the side of a Terex undercarriage. Three guylines are used on the tower.

Carriage description: A slackpulling carriage that is held in place by the haulback line. The strawline drum on the yarder is used to pay out the skidding line from the carriage. The mainline winds in the skidding line and subsequently pulls the carriage to the landing.

Crew size: 5 men

Average production: 250 pieces per day

System description: The carriage is pulled out by the haulback line. The skidding line is payed out of the carriage by pulling in on the strawline or slackpulling line. This operation also winds the mainline on one of the drums in the carriage. After the logs are choked, they are pulled to the carriage by the mainline.

Operational characteristics: During lateral yarding, the carriage is held in place with the haulback line. Even though the skyline is contained on a drum on the yarder, the skyline is not raised or lowered during the yarding cycle.

NORTH BEND SYSTEM

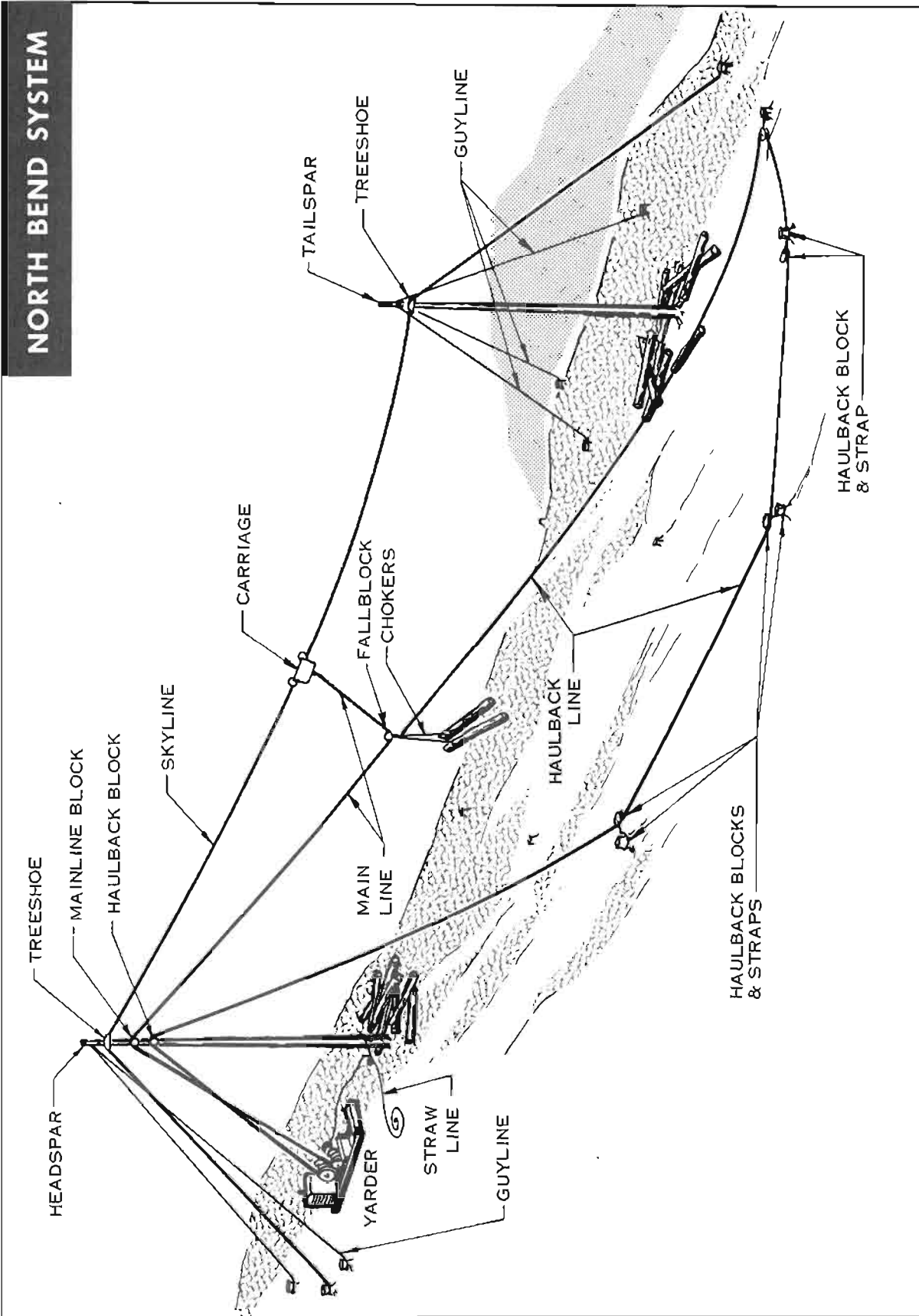

FIGURE 9-12

U S D E A R

NORTH BEND SYSTEM (Figure 9-12)

Yarding direction: Uphill

Cutting prescription: Clearcut or swing

Maximum yarding distance: 1,500 to 2,000 feet

Yarder description: A highlead yarder with mainline and haulback line may be used if the haulback drum has sufficient brakes to tightline the turn. If the skyline is stored on the yarder, a three-drum or slackline yarder is needed.

Tower and undercarriage description: A sled-mounted yarder with a rigged tree or a slackline tower with a track or wheeled undercarriage is commonly used.

Carriage description: The carriage is in two parts. A block carriage, such as a shotgun carriage, rides on the skyline. The mainline is attached to the bottom of the carriage. A fallblock is placed on the mainline with butt-rigging and haulback line attached to it.

Crew size: 6; yarder engineer, chaser, rigging slinger, two choker-setters and hooktender.

Average production: 25 MBF to 30 MBF per day

System description: The haulback line pulls the fallblock and butt-rigging back to the woods. The mainline pulls the carriage and turn into the landing. The standing skyline provides lift to the carriage and turn of logs.

Operational characteristics: Lateral capability is obtained by placing the haulback tailblock off to the side, thereby pulling the fallblock and chokers away from the skyline. If an obstacle is encountered, the fallblock can be raised by holding the haulback line tight while pulling in on the mainline. Full log suspension can be obtained by keeping tension on the haulback line. Usually, only one-end suspension is obtained. This system is often used for swinging.

SOUTH BEND SYSTEM

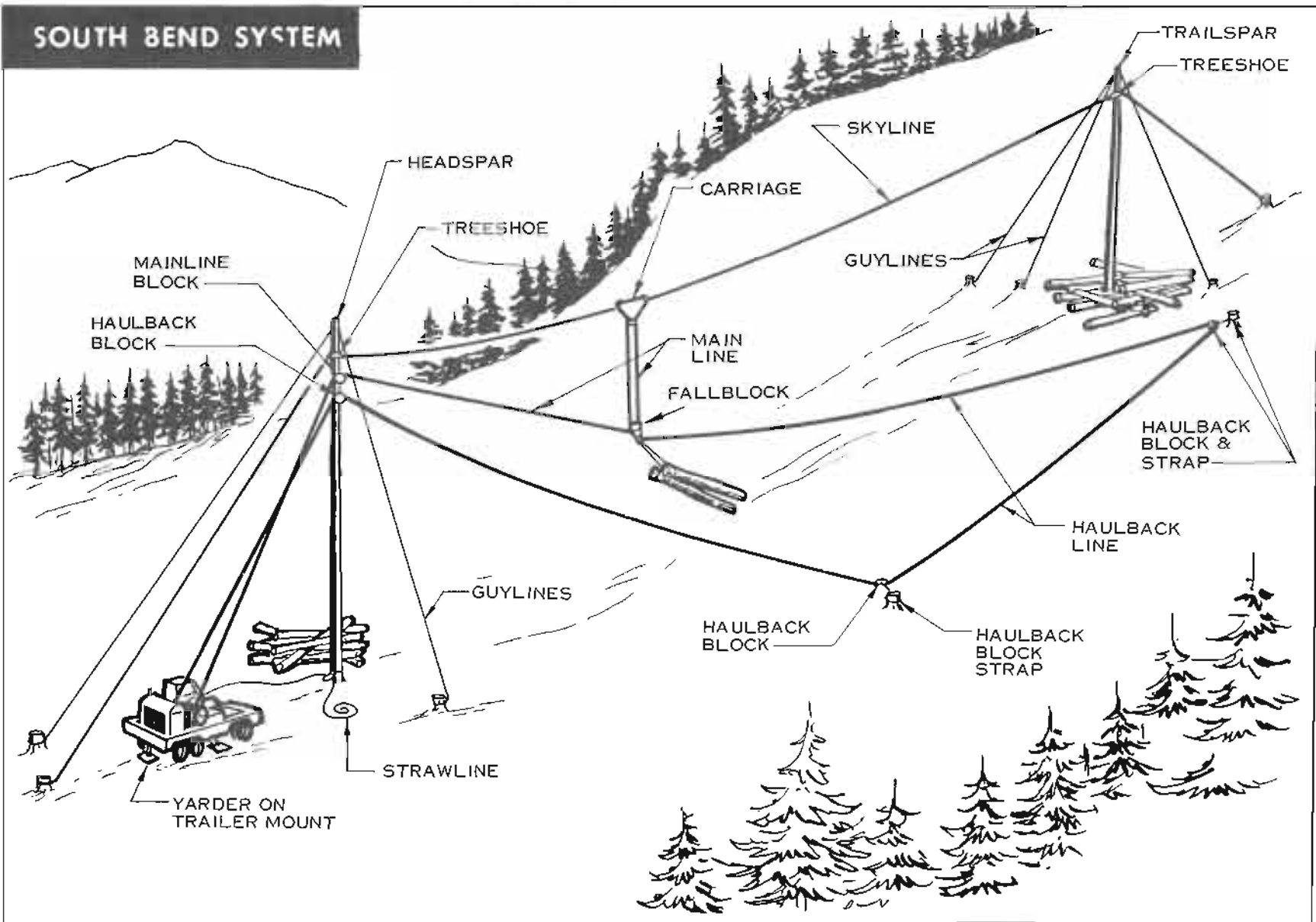
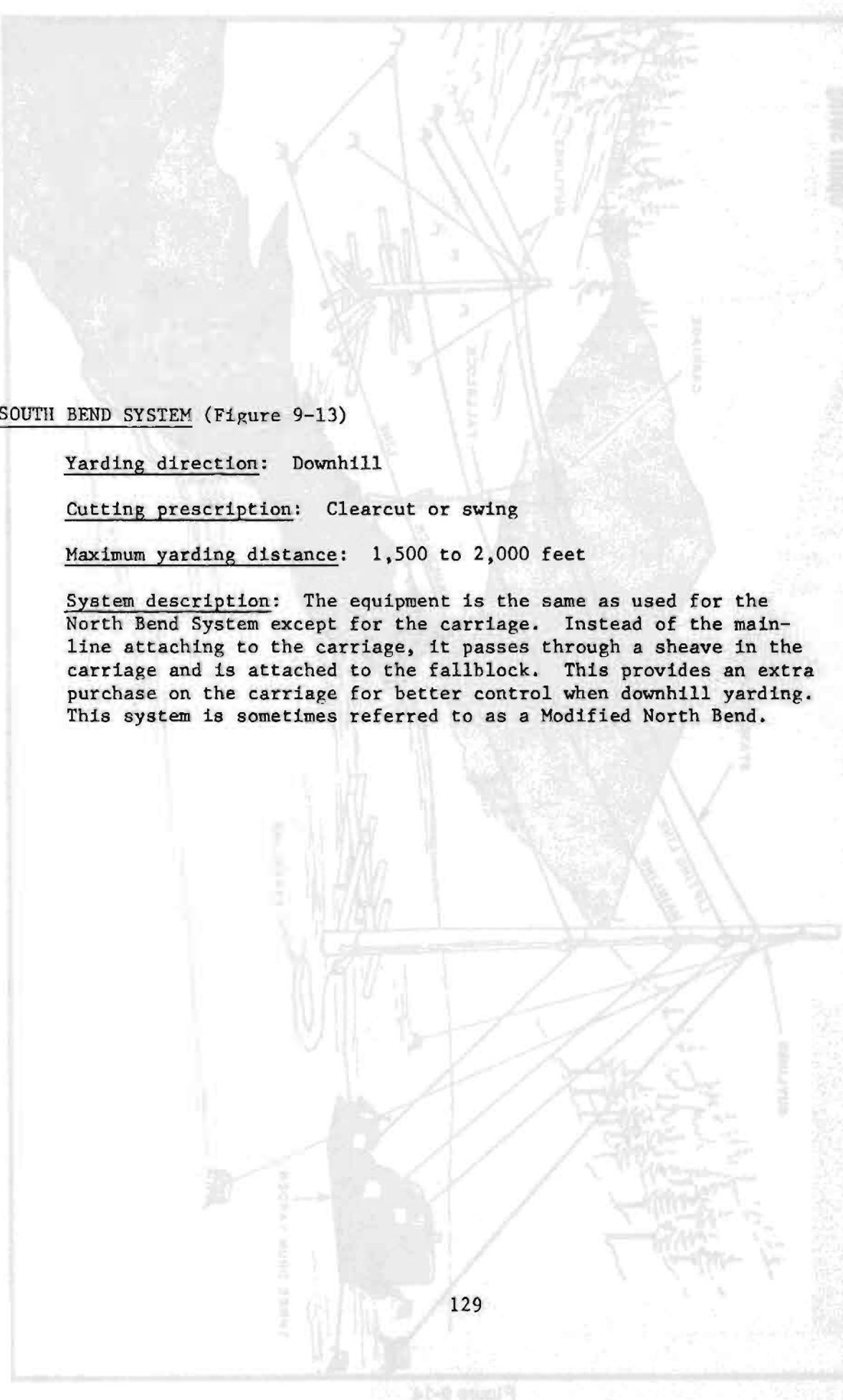

FIGURE 9-13



SOUTH BEND SYSTEM (Figure 9-13)

Yarding direction: Downhill

Cutting prescription: Clearcut or swing

Maximum yarding distance: 1,500 to 2,000 feet

System description: The equipment is the same as used for the North Bend System except for the carriage. Instead of the main-line attaching to the carriage, it passes through a sheave in the carriage and is attached to the fallblock. This provides an extra purchase on the carriage for better control when downhill yarding. This system is sometimes referred to as a Modified North Bend.

TYLER SYSTEM
Uphill Swing

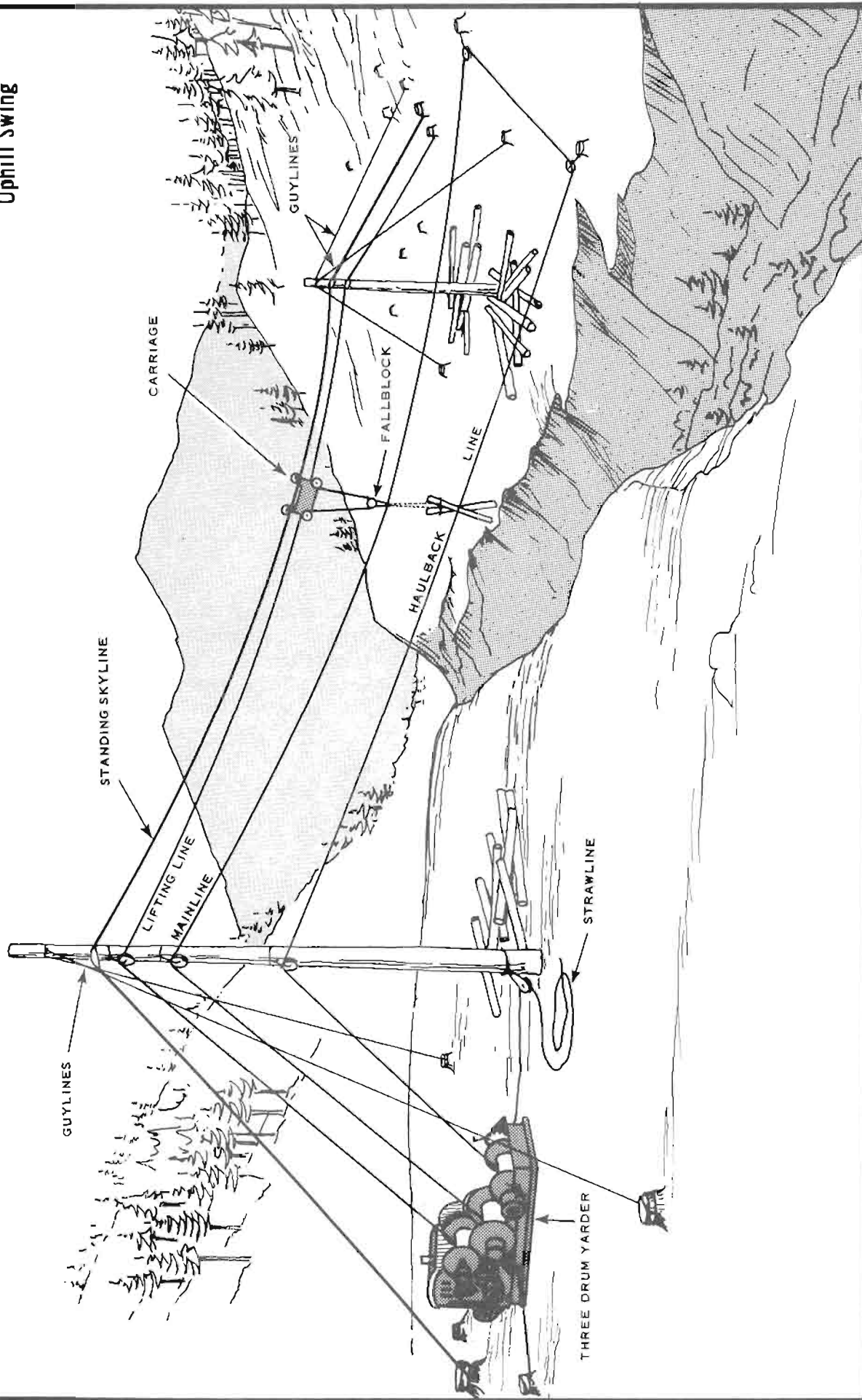

Figure 9-14



TYLER SYSTEM (Figure 9-14)

Yarding direction: Uphill

Cutting prescription: Clearcut or swing

Maximum yarding distance: 1,500 to 2,000 feet

Yarder description: A three-drum or slackline yarder is used. The main and haulback lines provide travel to the carriage. The lifting line holds the logs up to the carriage.

Tower and undercarriage description: A sled-mounted yarder with a rigged tree.

Carriage description: The carriage contains two sheaves on which the lifting line rides. A fallblock is placed on the lifting line. The butt-rigging, haulback, and mainlines are attached to the fallblock.

Crew size: 5 men

Average production: 25 MBF per day

System description: The standing skyline provides the lift for the carriage and logs. Usually it is not stored on a drum on the yarder. The lifting line is a stationary line during inhaul and is tensioned to hold the logs off the ground.

Operational characteristics: This system is used to swing logs across canyons. Operation is slow because of the way the lifting line passes through the carriage.

SKIDDER SYSTEM

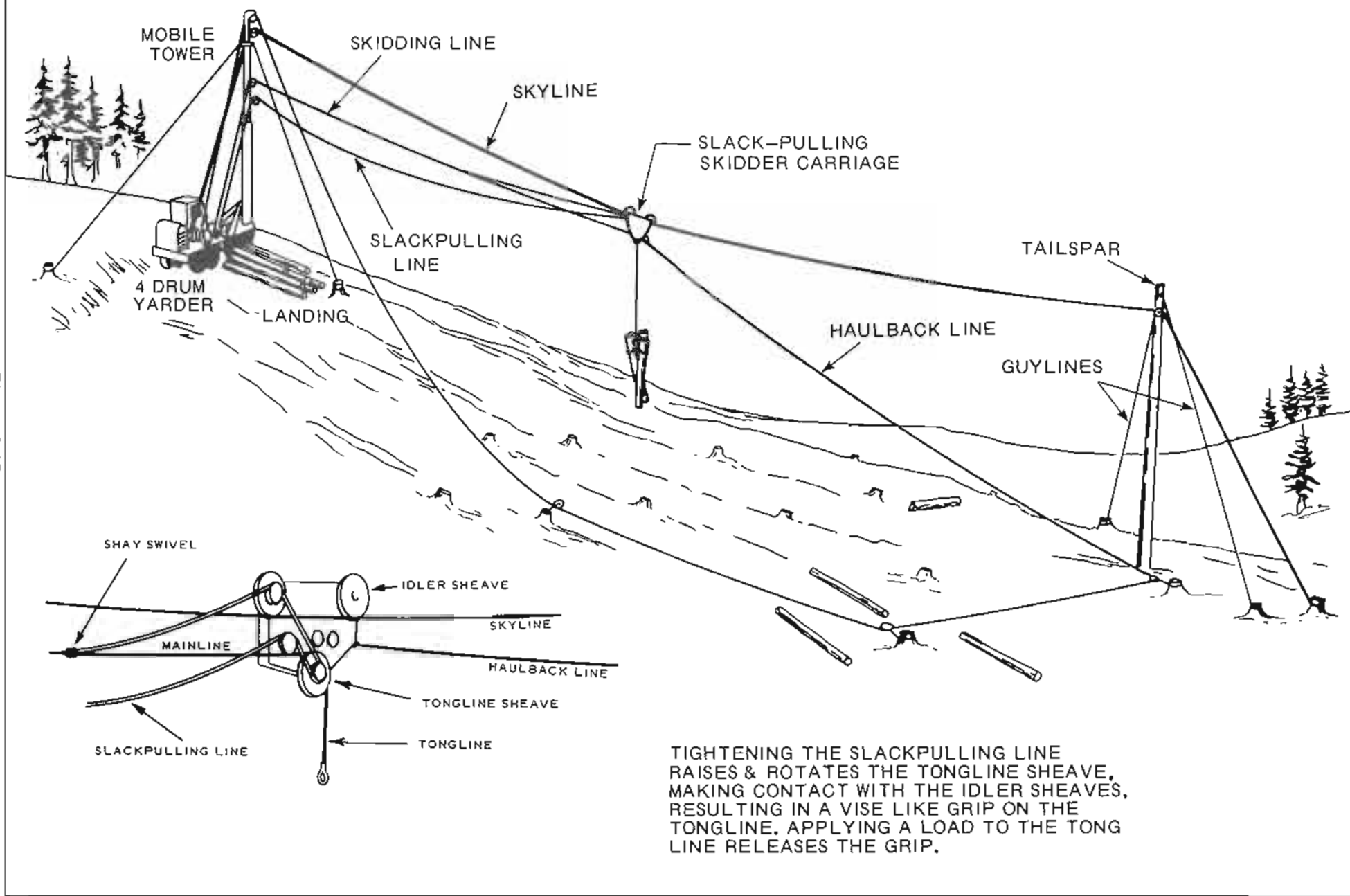

Figure 9-15

SKIDDER SYSTEM (Figure 9-15)

Yarding direction: Uphill or downhill

Cutting prescription: Thinnings, partial cuts, or clearcuts

Maximum yarding distance: 1,200 to 1,500 feet

Yarder description: A four-drum yarder is required: Skyline, haul-back line, mainline and slackpulling line.

Tower and undercarriage description: The four drums are mounted on a truck chassis with a fixed length tower. Sled-mounted yarders and rigged spar trees may also be used.

Carriage description: The carriage is mechanically operated. The slackpulling line pulls the mainline through the carriage. The logs are attached to the end of the mainline.

Crew size: 5 men

Average production: 200 to 250 pieces per day

System description: The system relies on the haulback line to hold the carriage in place during lateral yarding. The slackpulling line does not carry any load and, therefore, can be smaller than the mainline. In some cases a slackline yarder is rigged as a skidder by using the strawline for a slackpulling line.

Operational characteristics: Even though the skyline is attached to a drum on the yarder, this system is operated as a standing skyline. A carriage containing the skidding line on a drum may be used in place of the one shown in the diagram.

SKYFLYER SYSTEM

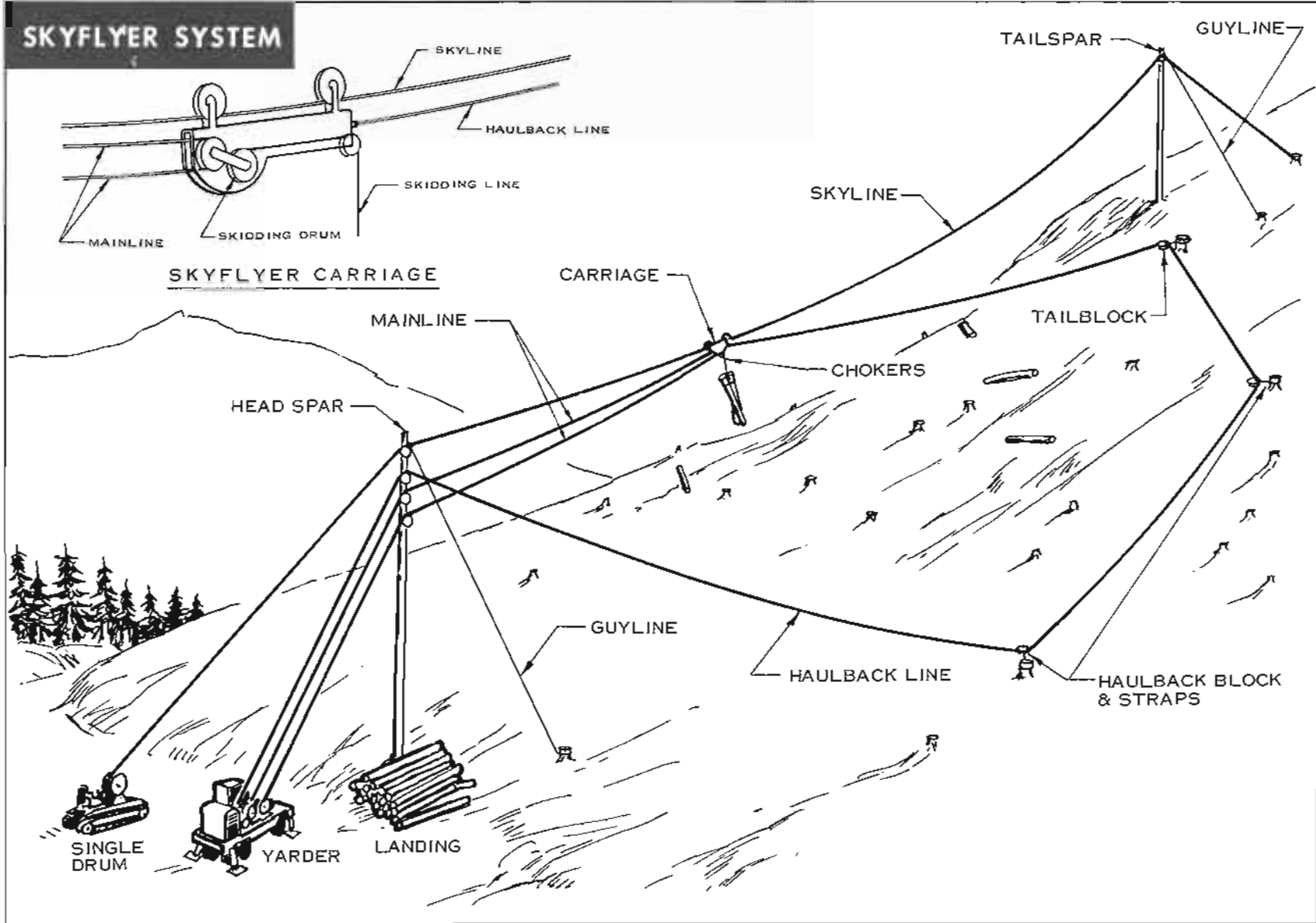

FIGURE 9-16

SKYFLYER SYSTEM (Figure 9-16)

Yarding direction: Uphill or downhill

Cutting prescription: Overstory removal or clearcut

Maximum yarding distance: 4,000 feet

Yarder description: Two main drums are interlocked with a haulback drum. The skyline is stored on a single drum line horse.

Tower and undercarriage description: A rigged spar tree is used with the track-mounted single drum and trailer-mounted yarder.

Carriage description: A slackpulling carriage which stores its own skidding line on a drum. The two mainlines power the skidding line in and out.

Crew size: 6; yarder engineer, hooktender, chaser, rigging slinger, and 2 choker setters.

Average production: 25 MBF to 30 MBF per day

System description: The haulback line pulls the carriage to the woods and holds it in place during lateral yarding. The two mainlines power the skidding line in and out and pull the turn to the landing.

Operational characteristics: All of the drums on the yarder are interlocked for positive control of the carriage, especially during downhill yarding.

EUROPEAN SKYLINE SYSTEM

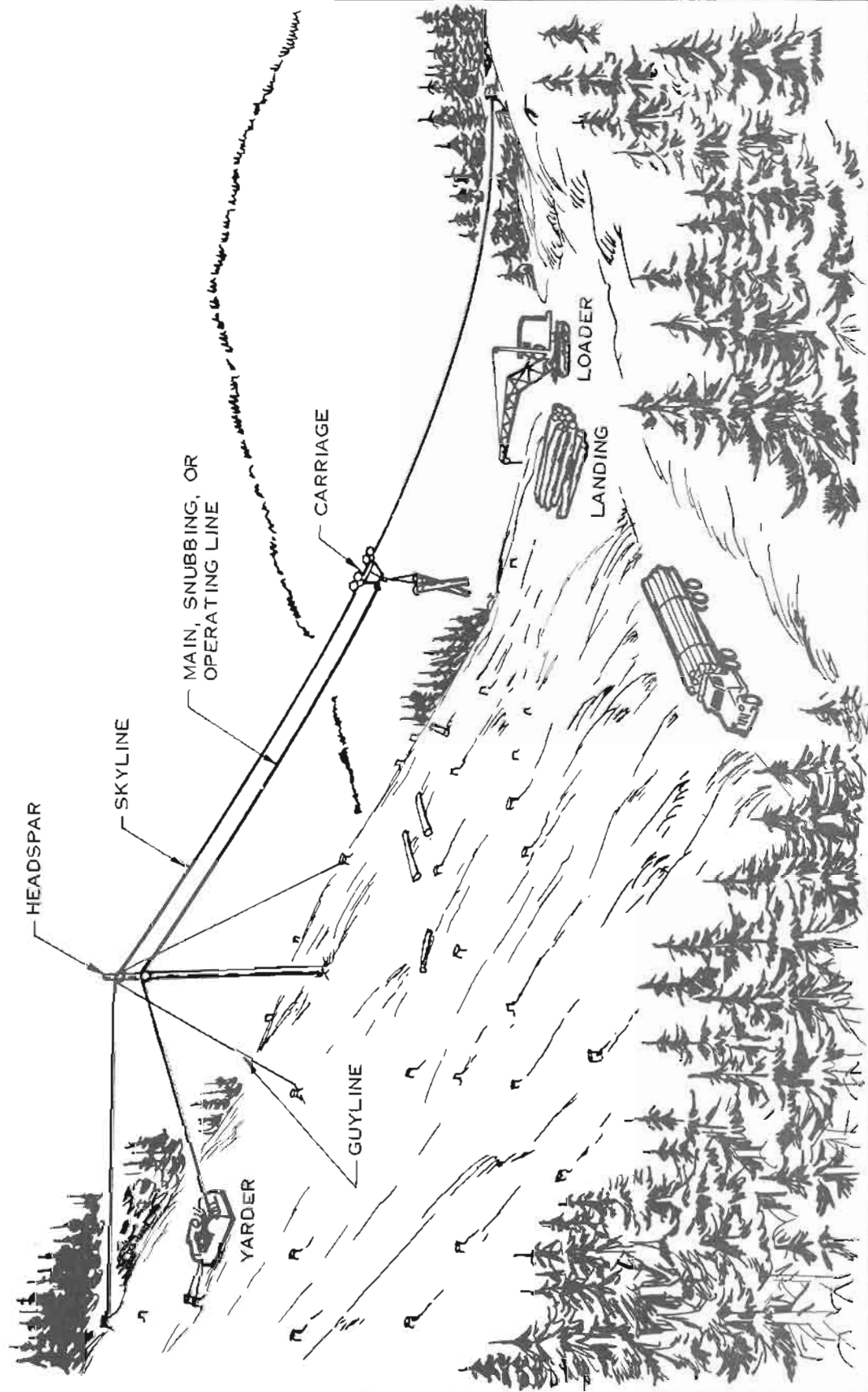

Figure 9-17

EUROPEAN SKYLINE SYSTEM (Figure 9-17)

Yarding direction: Downhill, may yard uphill if distances are less than 2,000 feet.

Cutting prescription: Overstory, shelterwood, clearcuts

Maximum yarding distance: 4,000 to 5,000 feet

Yarder description: A single drum which stores the mainline is powered by a diesel engine which ranges in horsepower from 15 to 200. An air fan on the yarder is used as a braking force to retard the load down the skyline to the landing.

Tower and undercarriage description: The yarder is sled-mounted. Spars are rigged trees. The yarder is designed to pull itself up the hill with its mainline.

Carriage description: The carriage is either mechanically or hydraulically operated. It clamps to the skyline and allows the mainline to be pulled through it. The butthook on the end of the mainline locks into the carriage and releases the clamp. The carriage operates on an automatically-timed cycle.

Crew size: 4 or 5 men

Average production: 20 MBF to 25 MBF per day

System description: The yarder acts as a snubber to lower the carriage and turn of logs to the landing. Once the carriage reaches the landing, it must go through an automatically-timed cycle to clamp it to the skyline and lower the logs to the ground.

Operational characteristics: Used mainly as a downhill system because the yarders do not have enough power to bring the logs uphill. Lateral yarding is accomplished by pulling the mainline through the carriage.

MULTISPAN SKYLINE

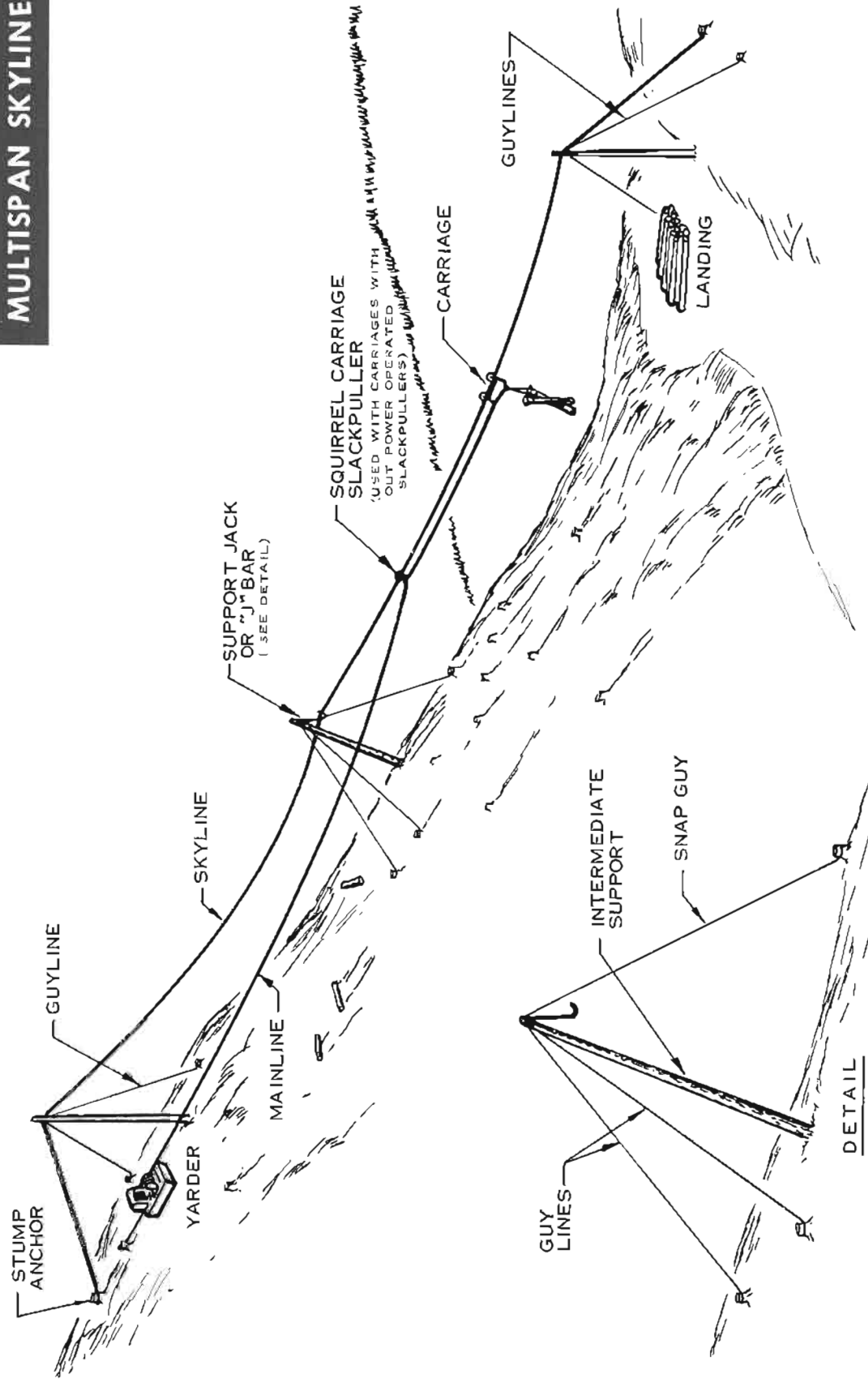

Figure 9-18

MULTISPAN SYSTEM (Figure 9-18)

Yarding direction: Downhill. Uphill yarding may be accomplished if the angle across the intermediate support is not too great. If there is slack in the lower span, the loaded carriage has trouble riding up and over the intermediate support.

Carriage description: The carriage must have open-sided sheaves so that it will pass across the intermediate support. If the carriage clamps to the skyline, the skyline clamp must swing away from the skyline.

System description: Most of the European Systems can be rigged multi-span. Production is decreased because the carriage has to be slowed down to cross the intermediate support. The squirrel carriage slackpuller, a block hung on the skyline to which the mainline is attached, is used to keep the belly out of the mainline to facilitate pulling slack by hand.

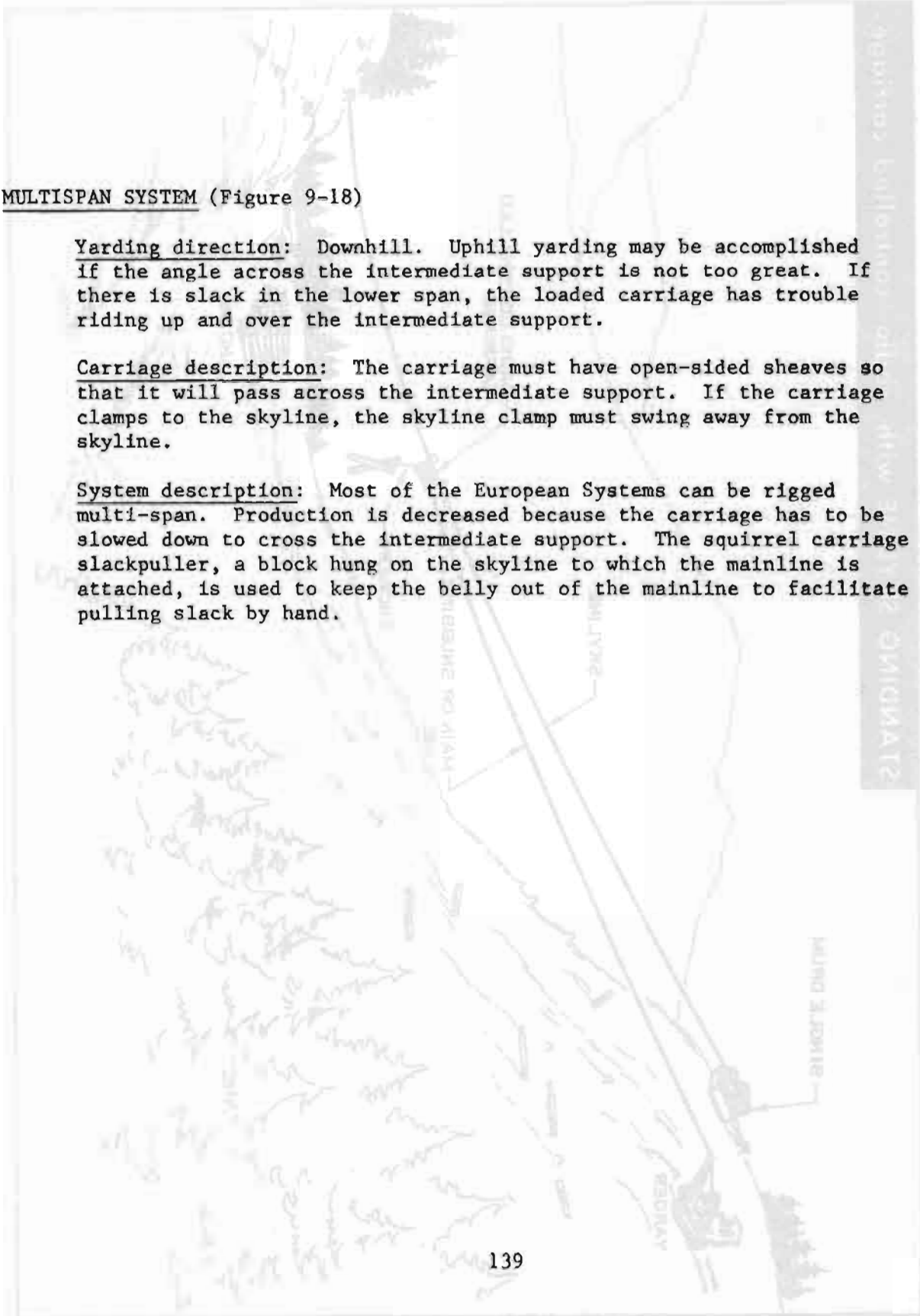

STANDING SKYLINE with radio controlled carriage

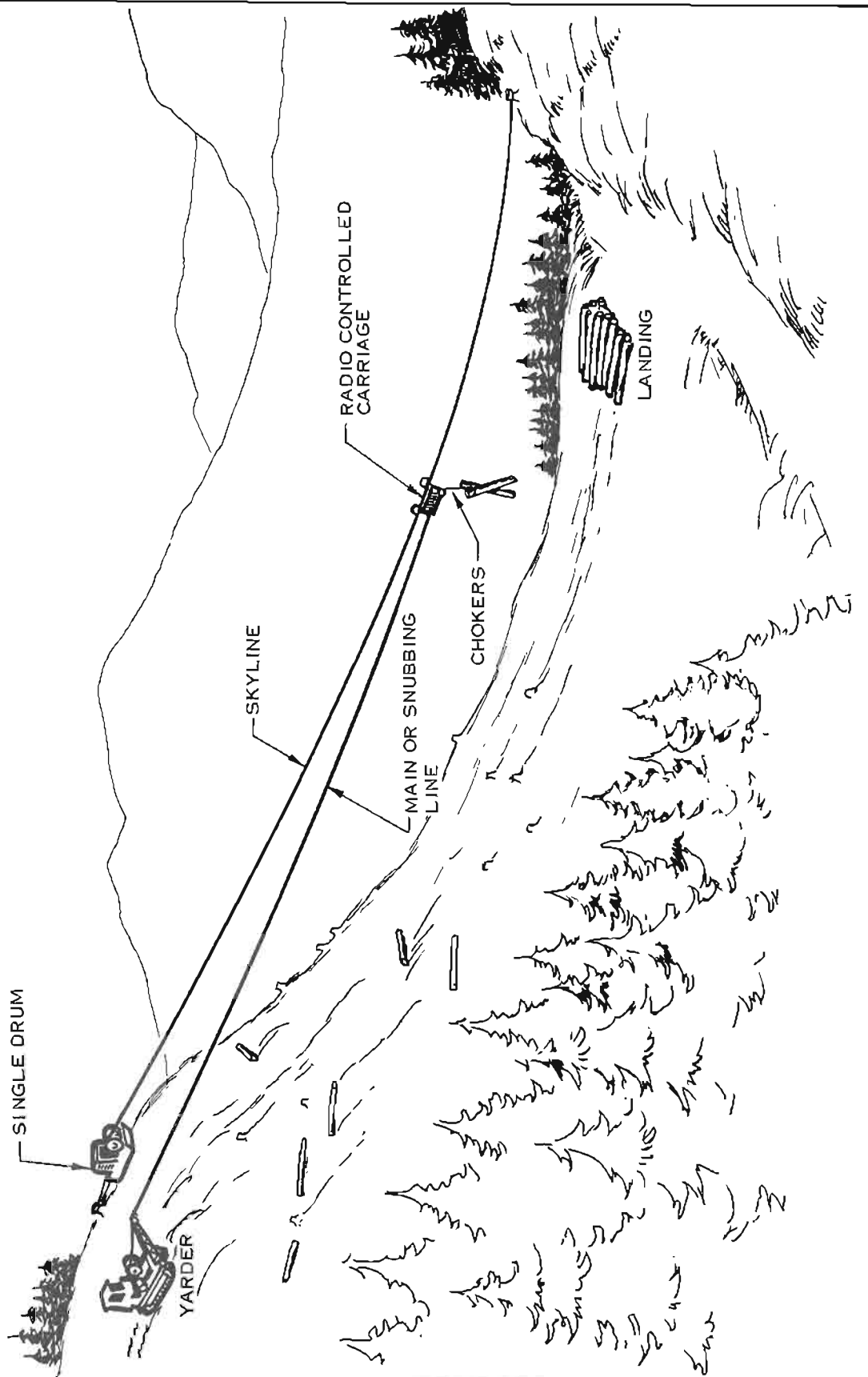

FIGURE 9-19



STANDING SKYLINE with Remote-Controlled Carriage (Figure 9-19)

Yarding direction: Uphill or downhill

Cutting prescription: Overstory removal, shelterwood or clearcut

Maximum yarding distance: 4,000 feet to 5,000 feet

Yarder description: The yarder can be a two-drum highlead. The gear ratio on the mainline drum is usually changed to increase line speeds. A single drum is used to spool and tension the skyline.

Tower and undercarriage description: As shown in the diagram, a headspar may not be needed if adequate deflection exists.

Crew size: 6 men

Average production: 35 MBF to 70 MBF per day. Usually about 75 to 100 pieces per day.

System description: The carriage returns to the woods under gravity in uphill logging. The skidding line is payed out and the logs attached. After the logs are lifted to the carriage, the mainline pulls the turn to the landing. For downhill yarding, the mainline lowers the turn down the skyline to the landing.

Operational characteristics: For downhill yarding, the yarder must have sufficient brakes to lower the turn to the landing. Older highlead yarders may require additional brakes.



STANDING SKYLINE - radio controlled carriage

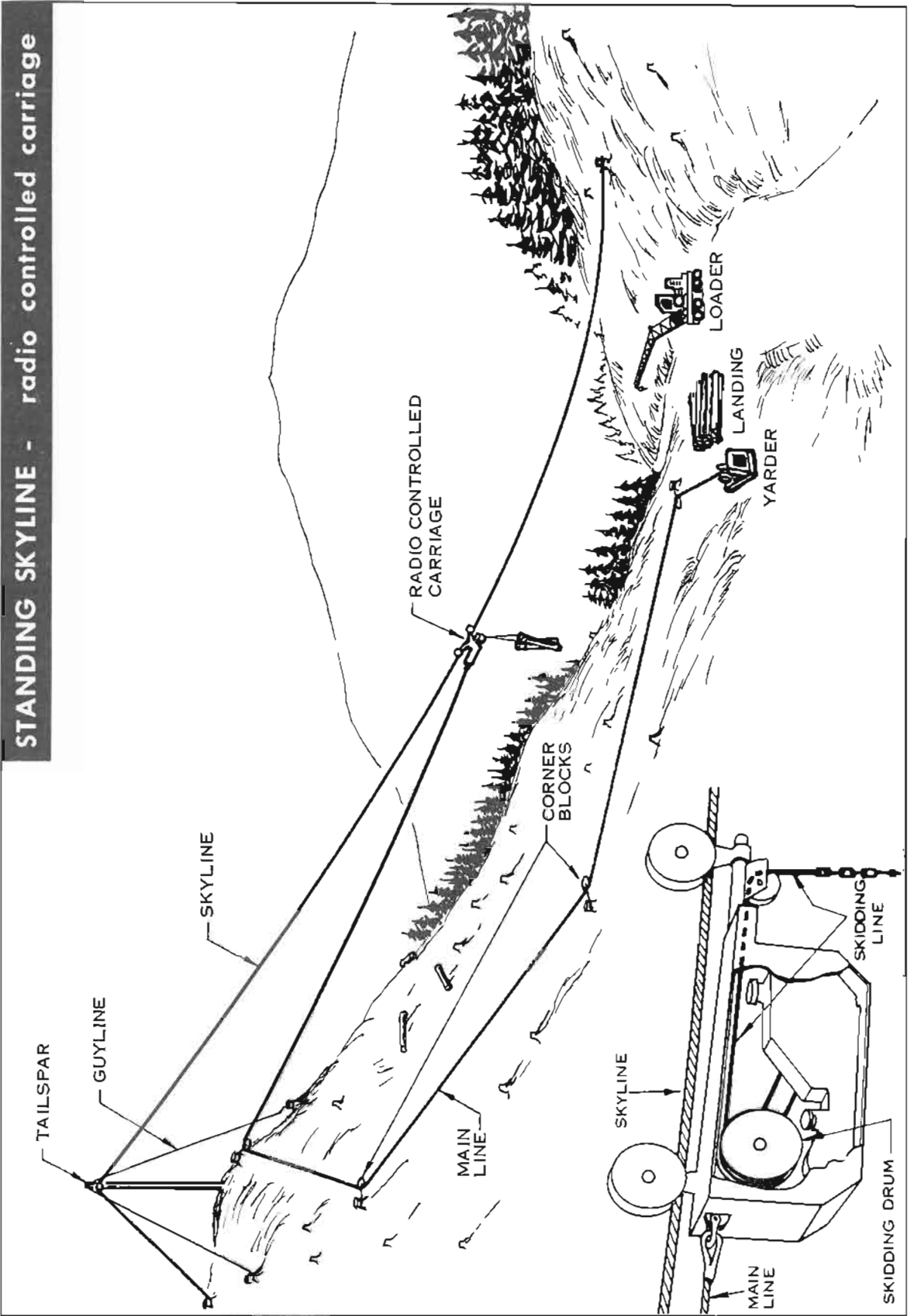
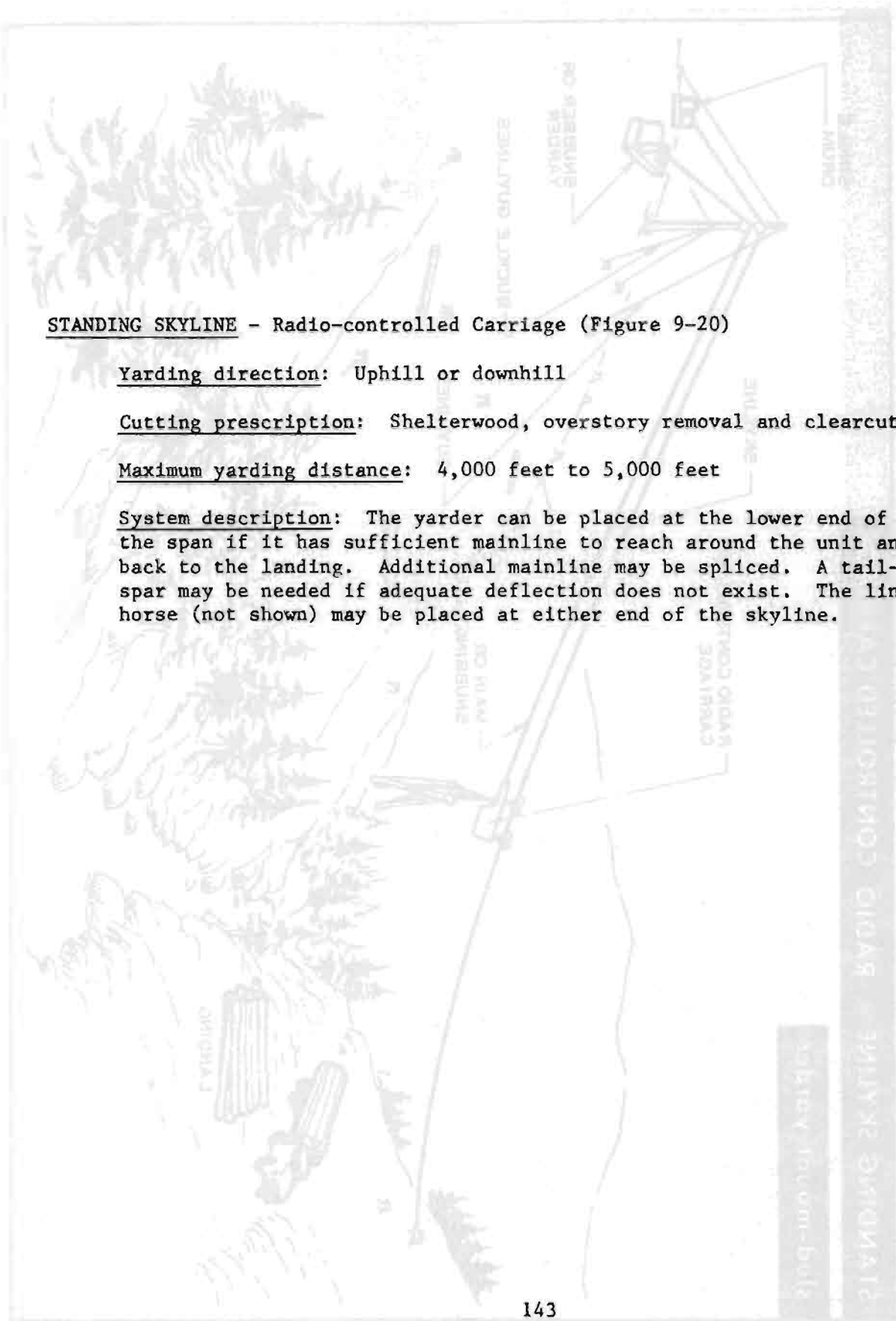

FIGURE 9-20



STANDING SKYLINE - Radio-controlled Carriage (Figure 9-20)

Yarding direction: Uphill or downhill

Cutting prescription: Shelterwood, overstory removal and clearcut

Maximum yarding distance: 4,000 feet to 5,000 feet

System description: The yarder can be placed at the lower end of the span if it has sufficient mainline to reach around the unit and back to the landing. Additional mainline may be spliced. A tail-spar may be needed if adequate deflection does not exist. The line horse (not shown) may be placed at either end of the skyline.

STANDING SKYLINE - RADIO CONTROLLED CARRIAGE

sled-mount yarder

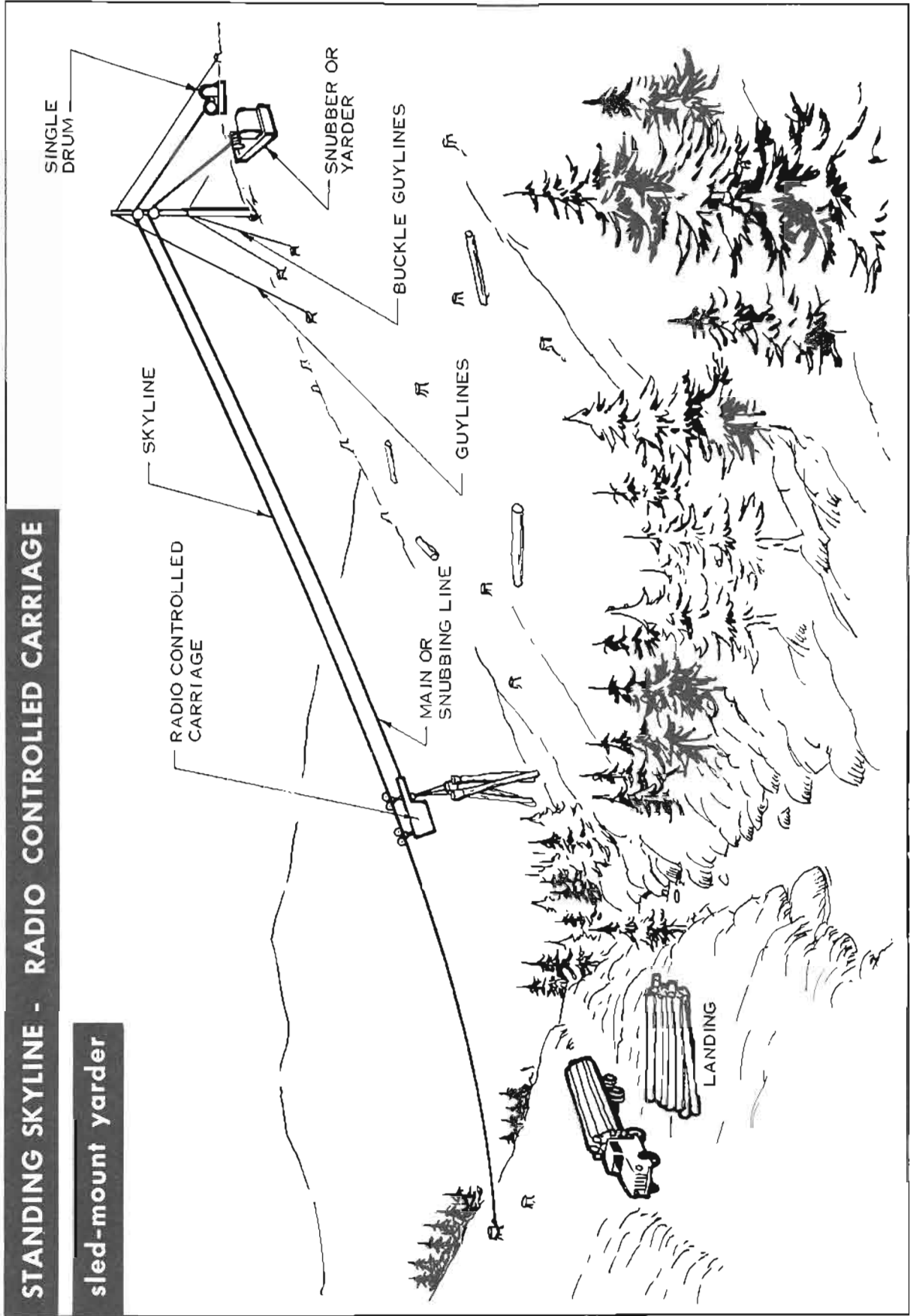

FIGURE 9-21



STANDING SKYLINE - Radio-Controlled Carriage - Sled-Mounted Yarder (Figure 9-21)

Yarding direction: Uphill or downhill

Cutting prescription: Shelterwood, overstory removal and clearcut

Maximum yarding distance: 4,000 feet to 5,000 feet

Yarder description: A two-drum highlead yarder with adequate brakes to hold the turn of logs when downhill yarding.

Tower and undercarriage description: The spar may be a rigged tree and the yarder can be sled-mounted.

Carriage description: Remote-controlled carriage with slackpuller.

Operational characteristics: If the carriage cannot reach the landing by gravity, a haulback line is required.

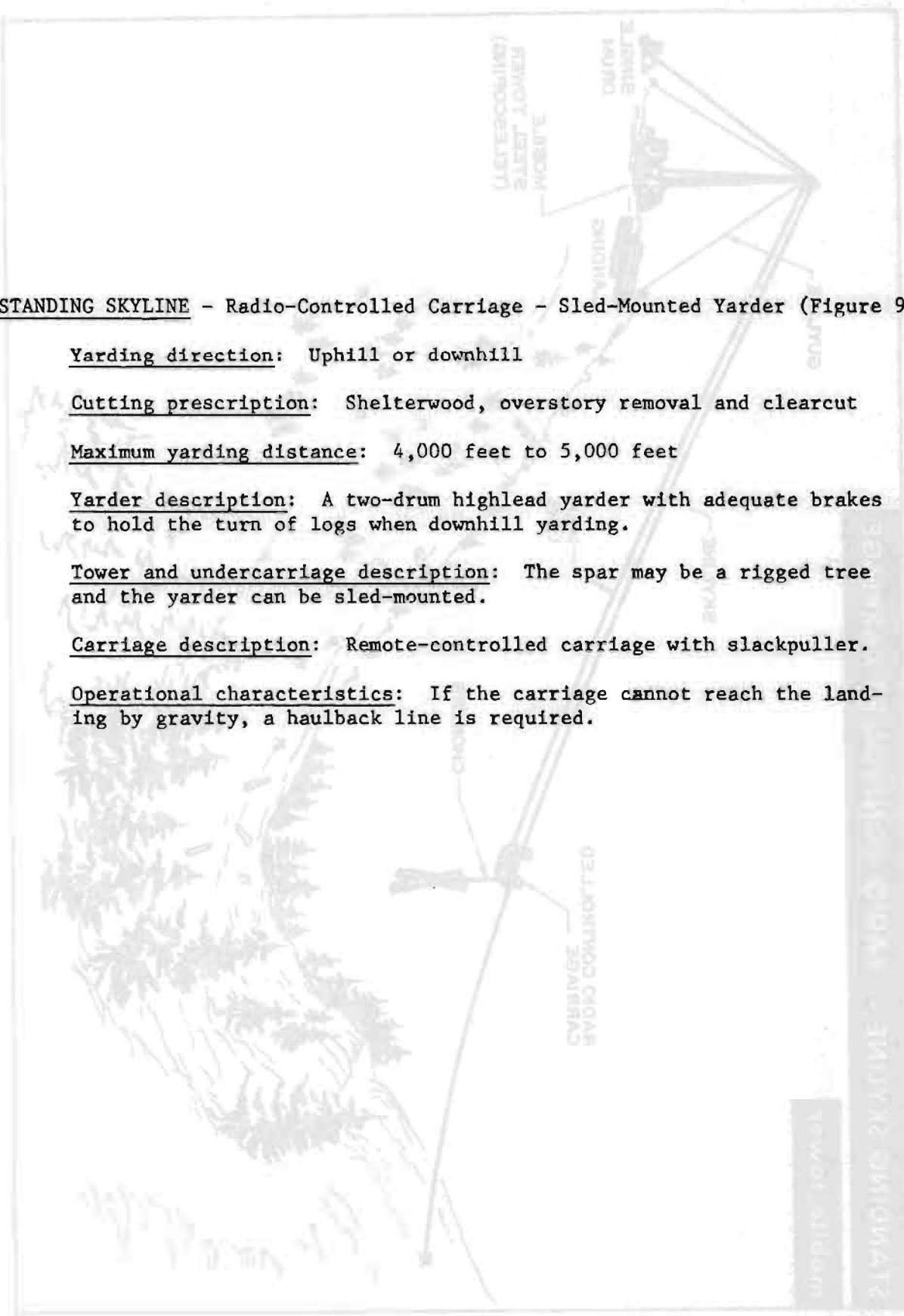

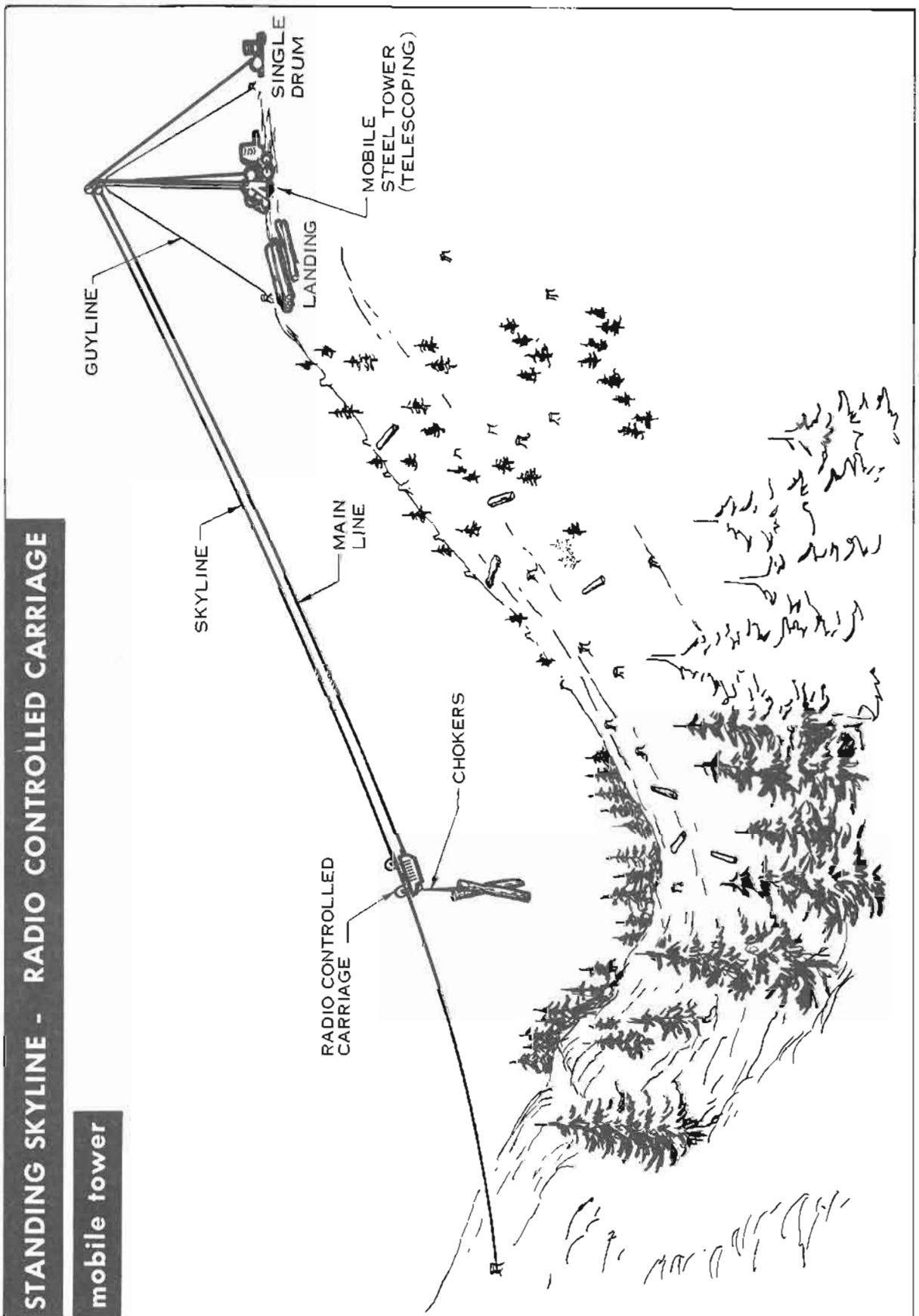

Figure 9-22



STANDING SKYLINE - Remote-Controlled Carriage - Mobile Tower (Figure 9-22)

Yarding direction: Uphill or downhill

Cutting prescription: Shelterwood, overstory removal and clearcuts

Maximum yarding distance: 4,000 feet to 5,000 feet

Yarder description: A two-drum highlead yarder with adequate brakes to lower the logs down the skyline and with adequate power to bring the turn uphill to the landing.

Tower and undercarriage description: The spar is usually a 110 or 120 foot telescoping tower with 8 guys. A heavy duty tower is recommended to handle 1-1/2-inch diameter skyline. A special fairlead is installed on top of the tower for the skyline.

Carriage description: A remote-controlled carriage capable of pulling slack.

Crew size: 6 men

Average production: 45 MBF to 70 MBF per day

System description: The carriage is returned to the woods under gravity. If adequate slope is not available, a haulback line is required. The carriage pays out the skidding line and the logs are attached. The logs are picked up and pulled to the landing with the mainline.

Operational characteristics: The single drum is placed at either anchor point. The landing must be in line with the anchor points so the skyline will not make a horizontal angle across the tower.

RUNNING SKYLINE with mechanical slack pulling carriage

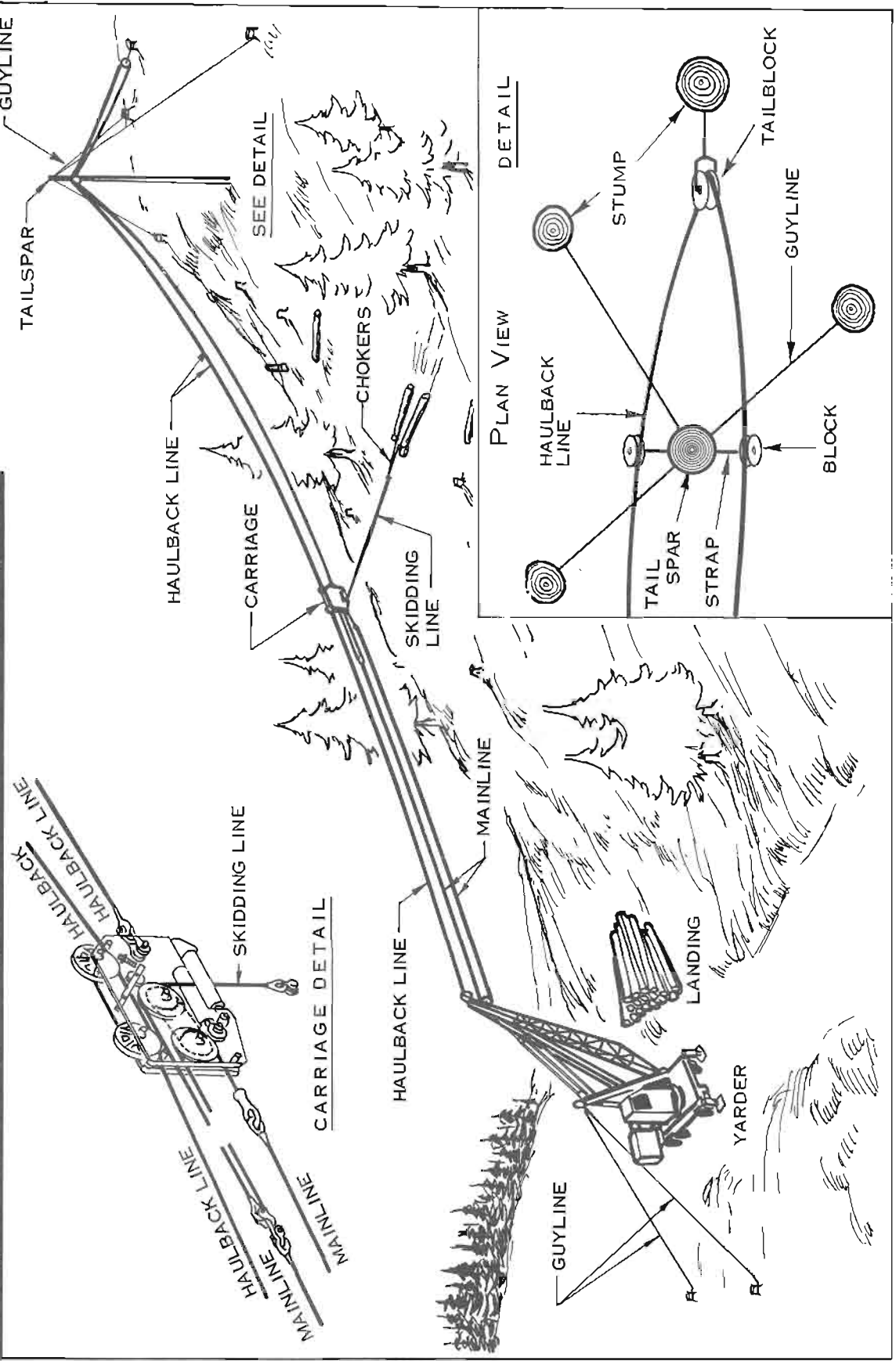

FIGURE 9-23

RUNNING SKYLINE With Mechanical Slackpulling Carriage (Figure 9-23)

Yarding direction: Uphill or downhill

Cutting prescription: Thinning, overstory removal, or clearcut

Maximum yarding distance: 1,000 feet uphill, 600 feet downhill

Yarder description: The yarder has three operating drums: Slackpulling, main and haulback. The slackpulling line pulls the skidding line out of the carriage. The mainline pulls the turn to the landing. The haulback line acts as a live skyline and also pulls the carriage back to the brush. Tension is maintained in the lines either by an interlock device or by brakes.

Tower and undercarriage description: The undercarriage has either rubber tires or tracks and is equipped with a turntable on which the yarder and tower are mounted. The leaning lattice tower is usually under 50 feet high.

Carriage description: The carriage is usually a mechanical slackpulling type with the skidding line either stored in a drum in the carriage or attached to the mainline as shown in figure 9-23. In either case, the slackpulling line, or lower mainline, is used to pull out the skidding line, and the upper mainline is used to pull the turn of the logs in to the carriage.

Crew size: 4 or 5 men

Average production: 150 to 300 pieces per day depending on material size.

System description: The carriage is pulled back to the brush with the haulback line. It is held in place by the haulback while the lateral skidding is accomplished. The two mainlines are operated in opposite directions to pay out the skidding line. The directions are reversed to pull in the skidding line. The turn of logs is brought to the landing by pulling on both mainlines.

Operational characteristics: The success of the system is dependent on proper tensions in the lines. This may be accomplished through an interlock device on the yarder. This device maintains the proper relationship in drum speeds so the haulback line travels at the same speed as the mainlines.

RUNNING SKYLINE with mechanical grapple

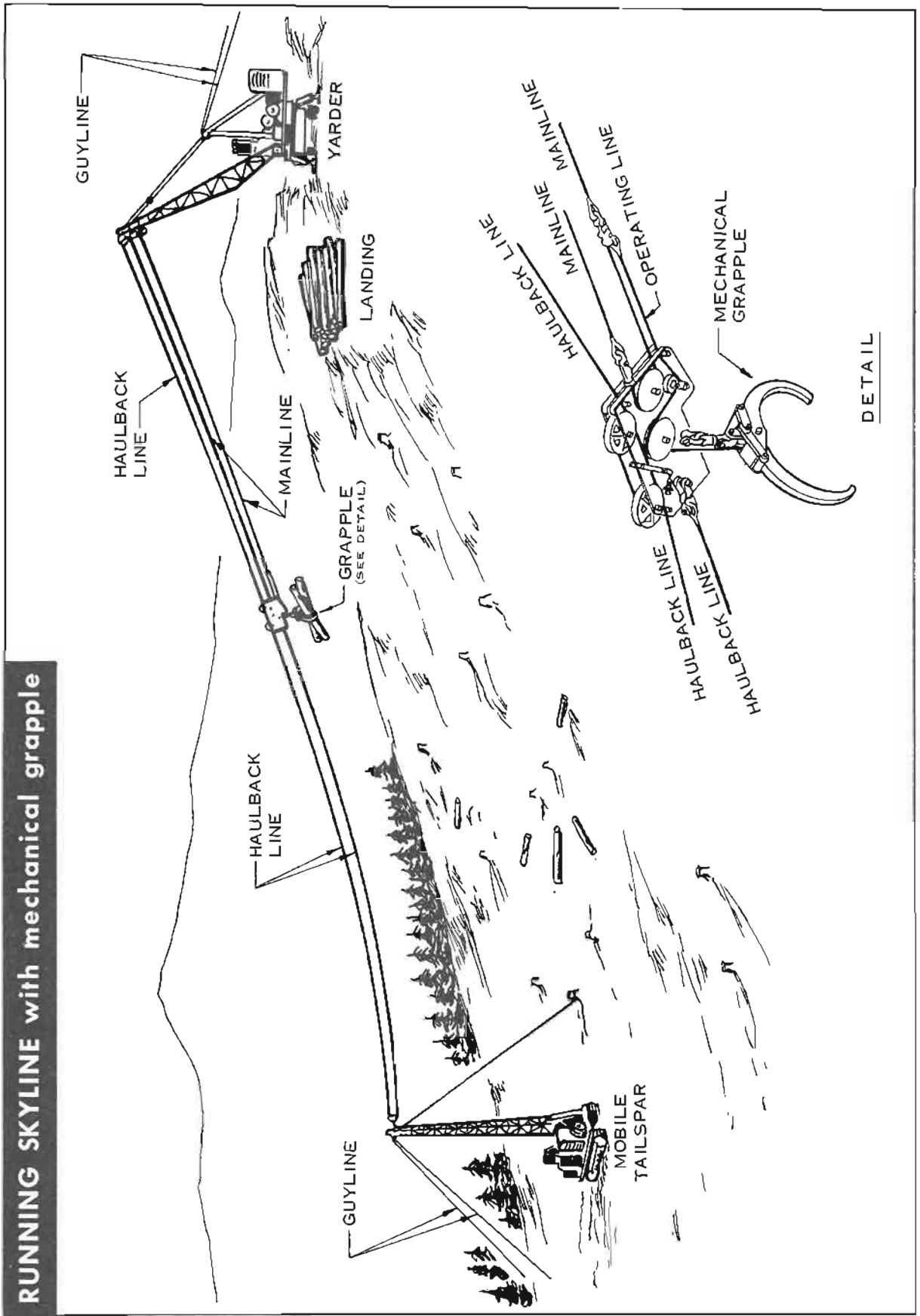

Figure 9-24

RUNNING SKYLINE With Mechanical Grapple (Figure 9-24)

Yarding direction: Uphill or downhill

Cutting prescription: Clearcut

Maximum yarding distance: 1,000 feet uphill, 600 feet downhill

Yarder description: The yarder has three operating drums: Slackpulling, main and haulback. The slackpulling line pulls the skidding line out of the carriage. The mainline pulls the turn to the landing. The haulback line acts as a live skyline and also pulls the carriage back to the brush. Tension is maintained in the lines either by an interlock device or by brakes.

Tower and undercarriage description: The undercarriage has either rubber tires or tracks and is equipped with a turntable on which the yarder and tower are mounted. The leaning lattice tower is usually under 50 feet high.

Carriage description: The mechanical grapple carriage is held in place with the haulback line. One mainline acts as a grapple-opening line. The other pulls the carriage to the landing. The grapple closes under its own weight. Power-closing grapples are available. The weight of the grapple holds the jaws open.

Crew size: 2 men; yarder-engineer and spotter

Average production: 150 to 160 pieces per day

System description: A spotter in the brush radios the yarder-engineer instructions on when to lower the grapple and close it. The spotter is also responsible for moving the tailblock which is usually mounted on a crawler tractor.

Operational characteristics: The swing-boom type yarder has three advantages over the fixed-tower type yarder:

1. It is easier to position the grapple over the logs.
2. Hangups are avoided during inhaul by swinging the boom.
3. Logs can be landed and decked to the side of the yarder instead of directly in front.

RUNNING SKYLINE with radio controlled grapple

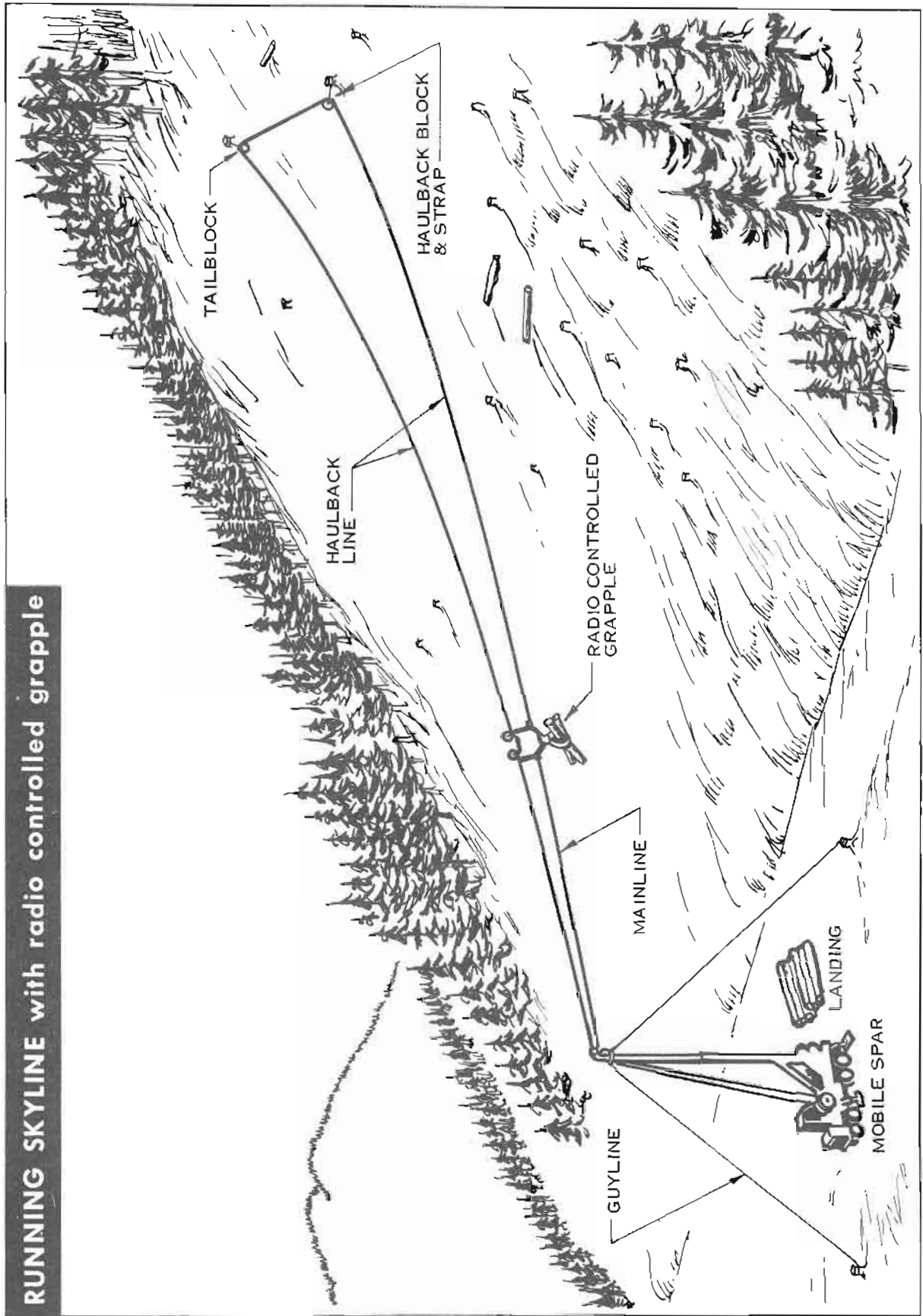
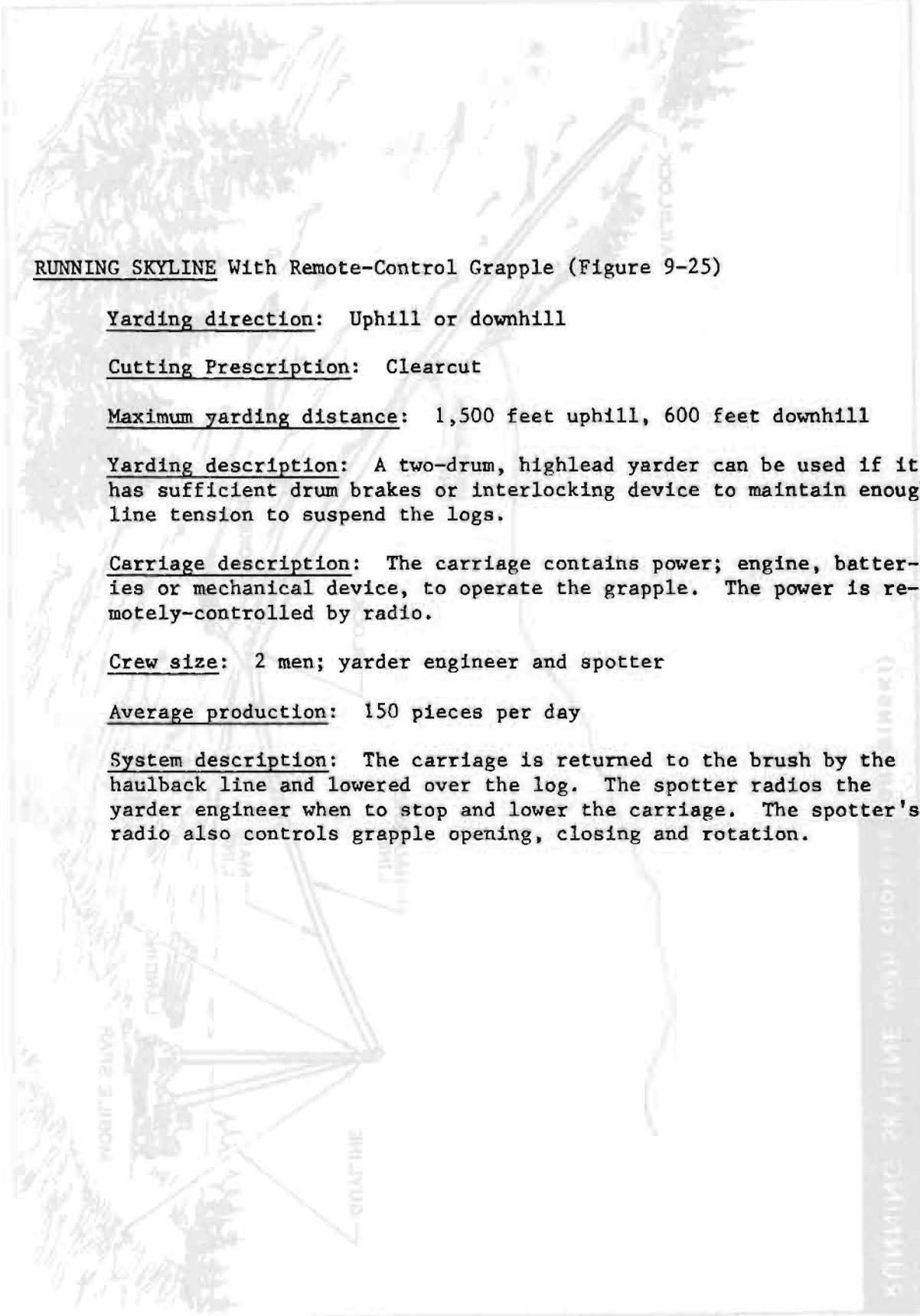

FIGURE 9-25





RUNNING SKYLINE With Remote-Control Grapple (Figure 9-25)

Yarding direction: Uphill or downhill

Cutting Prescription: Clearcut

Maximum yarding distance: 1,500 feet uphill, 600 feet downhill

Yarding description: A two-drum, highlead yarder can be used if it has sufficient drum brakes or interlocking device to maintain enough line tension to suspend the logs.

Carriage description: The carriage contains power; engine, batteries or mechanical device, to operate the grapple. The power is remotely-controlled by radio.

Crew size: 2 men; yarder engineer and spotter

Average production: 150 pieces per day

System description: The carriage is returned to the brush by the haulback line and lowered over the log. The spotter radios the yarder engineer when to stop and lower the carriage. The spotter's radio also controls grapple opening, closing and rotation.

RUNNING SKYLINE with chokers (GRABINSKI)

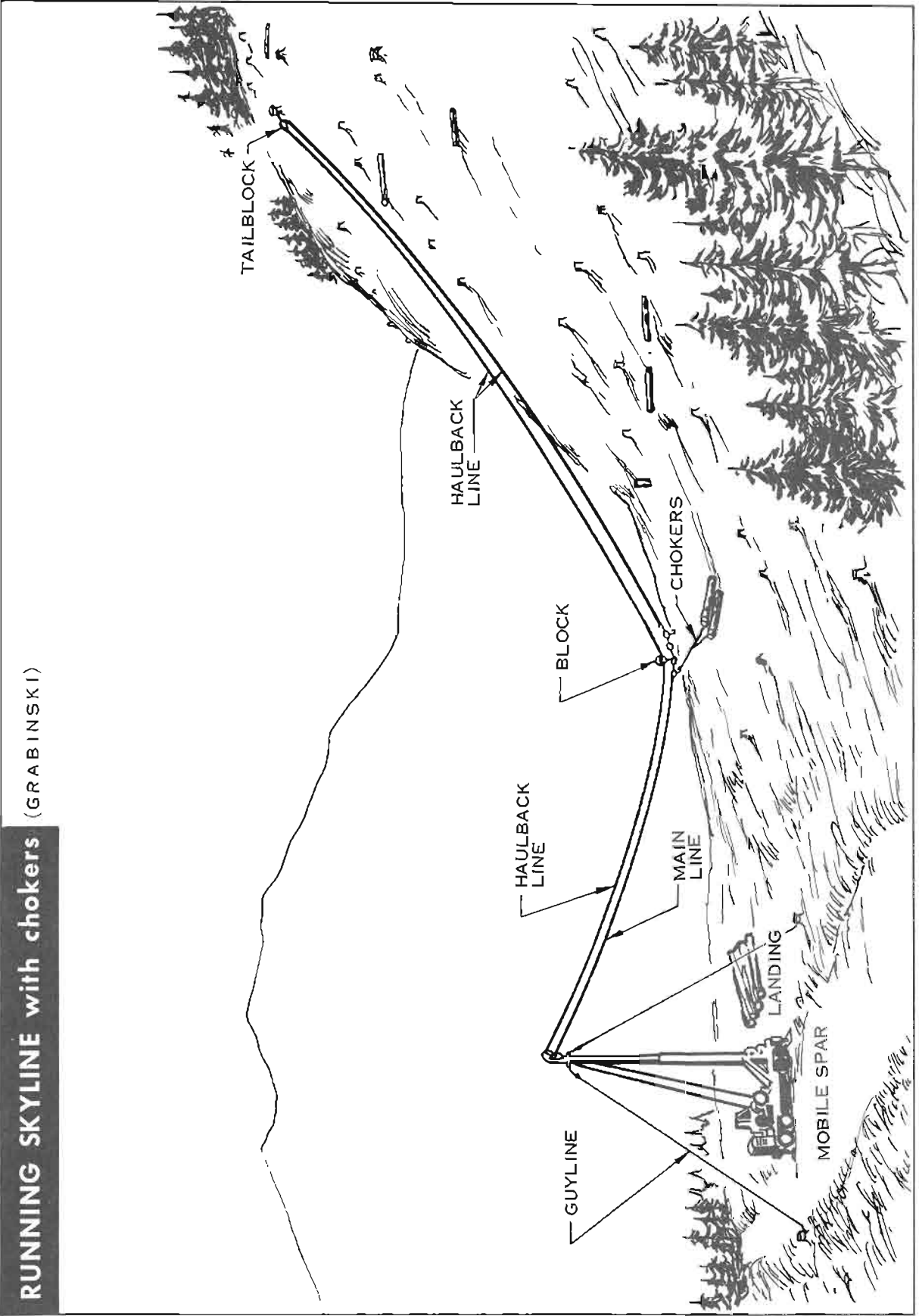
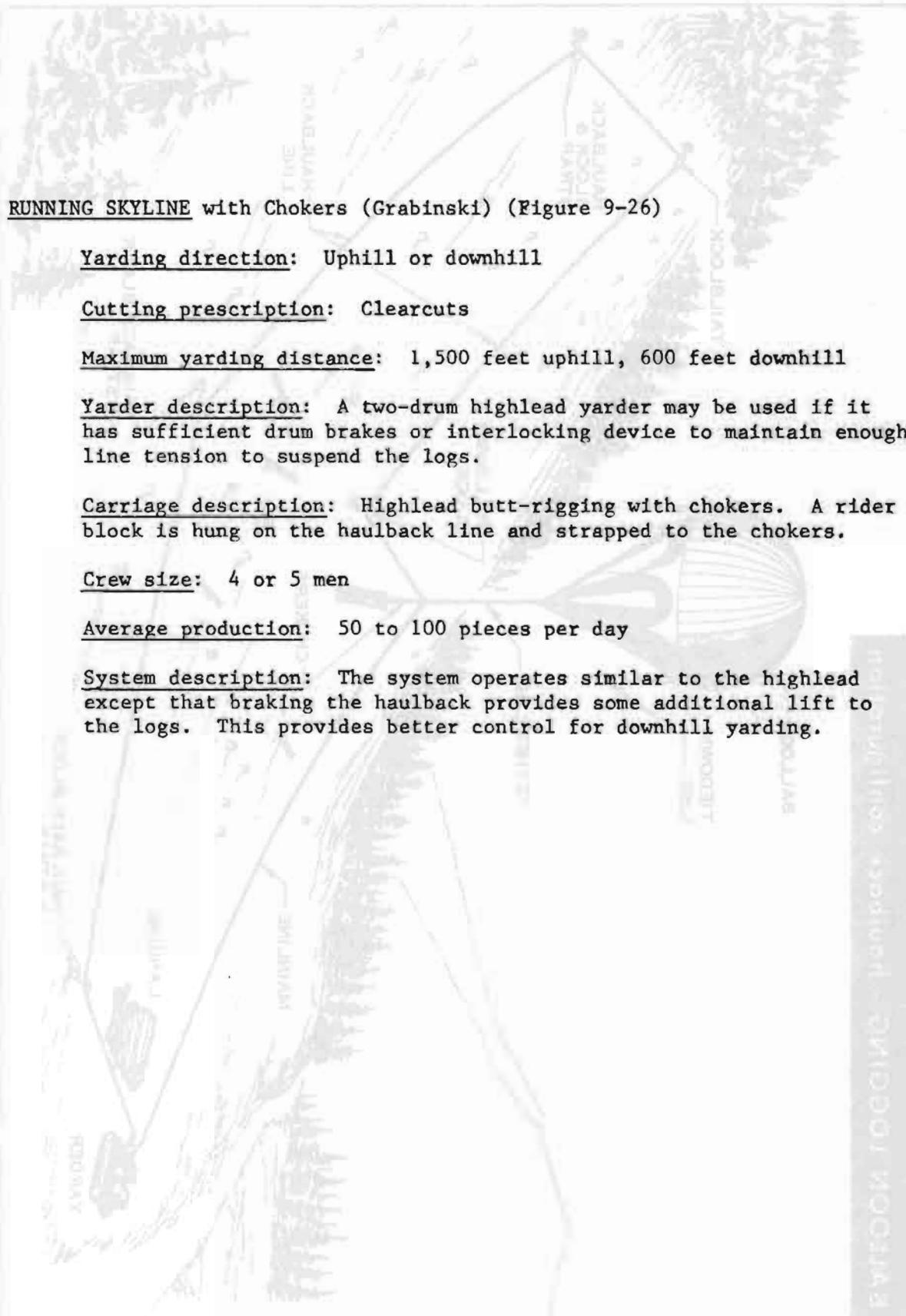

FIGURE 9-26





RUNNING SKYLINE with Chokers (Grabinski) (Figure 9-26)

Yarding direction: Uphill or downhill

Cutting prescription: Clearcuts

Maximum yarding distance: 1,500 feet uphill, 600 feet downhill

Yarder description: A two-drum highlead yarder may be used if it has sufficient drum brakes or interlocking device to maintain enough line tension to suspend the logs.

Carriage description: Highlead butt-rigging with chokers. A rider block is hung on the haulback line and strapped to the chokers.

Crew size: 4 or 5 men

Average production: 50 to 100 pieces per day

System description: The system operates similar to the highlead except that braking the haulback provides some additional lift to the logs. This provides better control for downhill yarding.

BALLOON LOGGING - haulback configuration

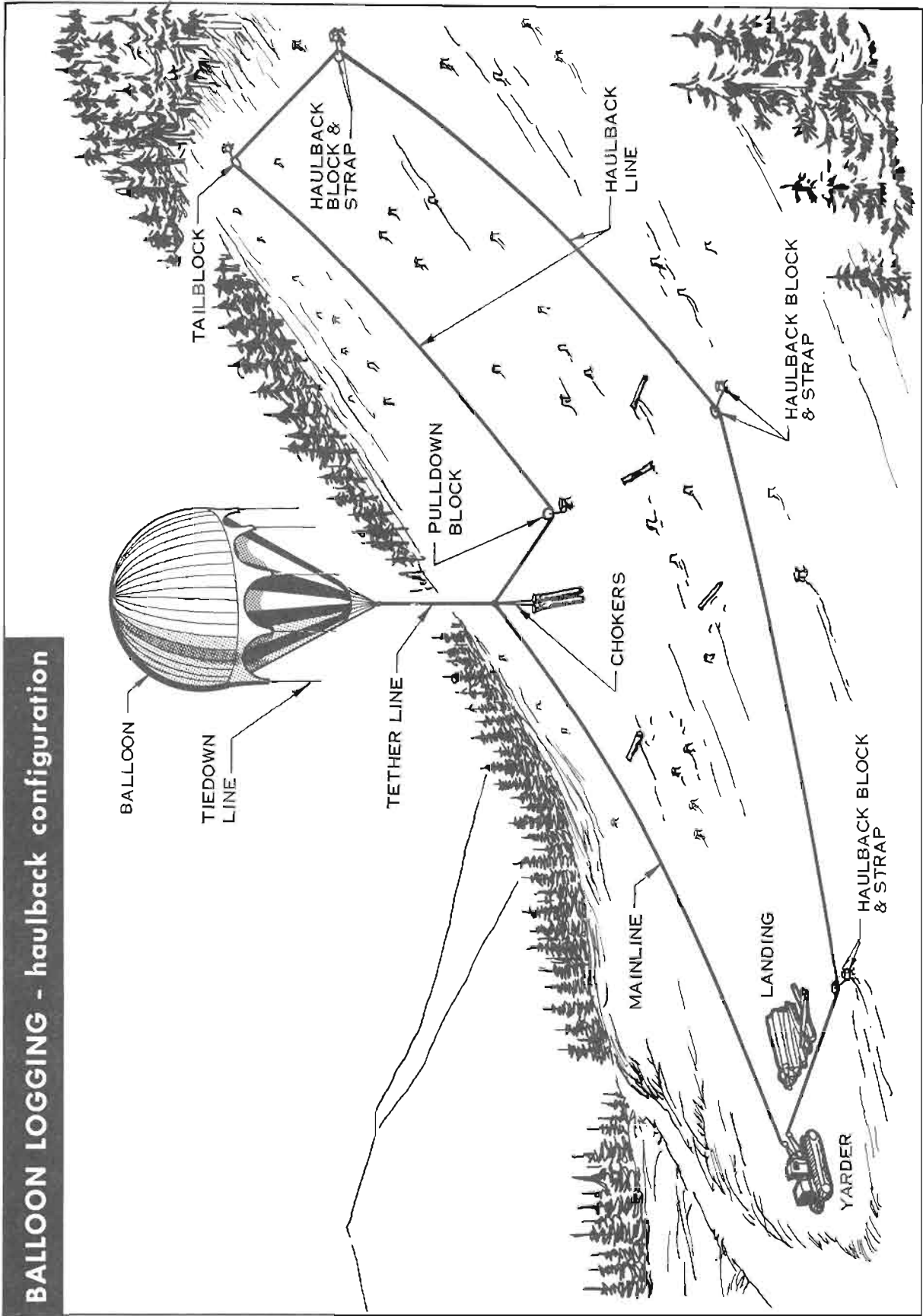

Figure 9-27



BALLOON LOGGING - Haulback Configuration (Figure 9-27)

Yarding direction: Downhill

Cutting prescription: Clearcut and overstory removal

Maximum yarding distance: 4,000 feet

Yarder description: A two-drum interlocking yarder capable of storing 5,500 feet of 1-inch mainline and 7,000 feet of 1-inch haulback line. The yarder is track-mounted and weighs approximately 172,000 pounds.

Balloon description: The fabric is Dacron with a Neoprene lining. It is approximately 105 feet in diameter and holds 530,000 cubic feet of helium. Load capacity is approximately 25,000 pounds.

Crew size: 4 or 5 men

Average production: 100 to 150 pieces per day

System description: The system is rigged in the highlead configuration with a haulback and mainline. The balloon suspends the butt-rigging. Logs are lifted vertical and flown free of the ground. Suited for use on convex slopes.

Operational characteristics: A bedding ground is needed to initially inflate the balloon and to park it during adverse weather. A crawler tractor with special winches is used as a transfer vehicle. Wind and rain or wet snow hamper the balloon's operation.

BALLOON LOGGING - inverted skyline configuration

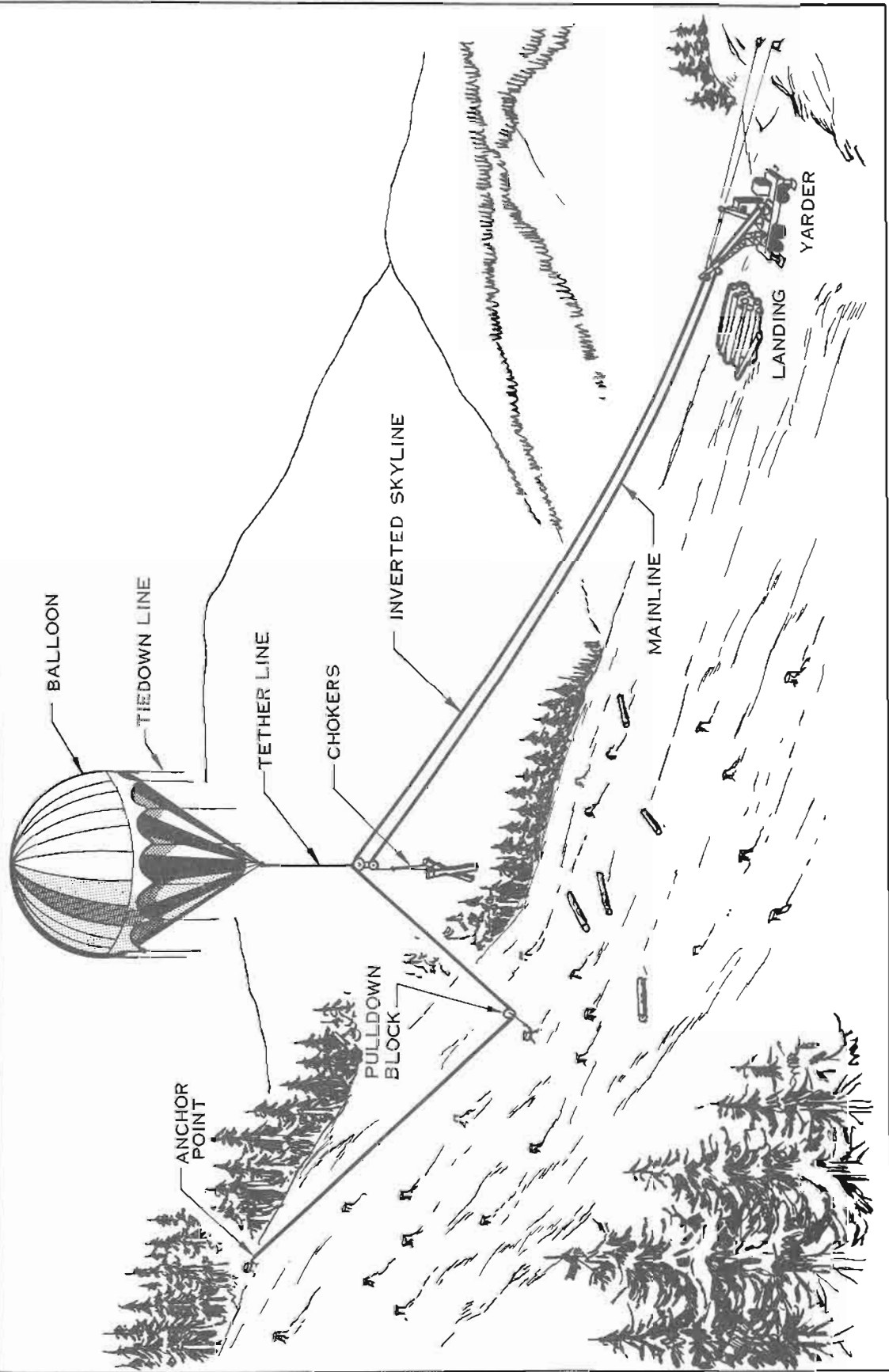

FIGURE 9-28

BALLOON LOGGING - Inverted Skyline Configuration (Figure 9-28)

Yarding direction: Downhill

Cutting prescription: Clearcut

Maximum yarding distance: 4,000 feet

Yarder description: A two-drum interlocking yarder capable of storing 5,500 feet of 1-inch mainline and 7,000 feet of 1-inch haulback line. The yarder is track-mounted and weighs approximately 172,000 pounds.

Balloon description: The fabric is Dacron with a Neoprene lining. It is approximately 105 feet in diameter and holds 530,000 cubic feet of helium. Load capacity is approximately 25,000 pounds.

Carriage description: The block carriage is held under the skyline by the lifting force of the balloon. The tagline to the ground is attached to the bottom of the carriage.

Crew size: 4 or 5 men

Average production: 100 to 150 pieces per day

System description: When the tension is released in the mainline, the carriage runs up the skyline due to the lifting force of the balloon. At the point of loading, the balloon is pulled down by tensioning the skyline until the chokers reach the ground. The logs are lifted by releasing the tension in the skyline. The turn is brought to the landing by pulling in the mainline.

Operational characteristics: This rigging configuration eliminates the haulback line, thus reducing the fire hazard.

SUMMARY OF CABLE SYSTEMS

Cable System	Fig. 9-	Harv. Meth.			Yard. Dist.		Skyline Size (In.)	Carriage Type	Yarder Type
		CC	OR	TH	UP (Ft)	Down			
1. Ground Lead									
a) Shovel Loader	1	x	x	x	300	0	1/2-3/4 ^{5/}	Tongs	Single drum loader, heelboom
b) Jammer w/wood boom	2	x			700	0	1/2-3/4 ^{5/}	Squirrel block & Tongs	Two-drum, truck mounted
c) Mobile Shovel Yarder	3	x			700	0	5/8-1 ^{5/}	Butt rigging	Two-drum, converted loader
d) Highlead	4	x			1,000	600	3/4-1-1/2 ^{5/}	Butt rigging	Two-drum, main & haulback
2. Live Skyline									
a) Mechanical Carr.	5			x	1,000	0	5/8-1	Hydraulic clamp; slackpulled by hand	Two-drum, mobile yarder
b) Shotgun (flyer)	6	x			2,000	2/	3/4-1-1/2	Block	Two-drum, skyline & main
c) Slackline	7	x	3/		2,500	1,000	1-1-1/2	Block	Three-drum, skyline, main & haulback
d) Remote-control Carriage	8	x	x	x	2,000	2/	1-1-1/2	Self-contained radio-controlled	Two or three drums
e) Radio-Controlled Grapple	9	x			2,000	2/	1-1-1/2	Grapple	Two-drum
f) Side Mount	11	x	x	x	1,000	500	1-1-1/8	Slackpulling held by haulback	Four-drum, skyline, main haulback & slackpulling
3. Standing Skyline									
a) North Bend	12	x			2,000	1,500	1-1/8-1-1/2	Block	Three-drum
b) South Bend	13	x			1,500	1,500	1-1/8-1-1/2	Block	Three-drum
c) Tyler	14	x			2,000	1,500	1-1/8-1-1/2	Block	Three drums plus skyline
d) Skidder	15	x	x	x	1,500	1,500	1-1-1/2	Mech. Slackpull.	Four-drum
e) Skyflier	16	x	x		4,000	4,000	1-3/4	Mech. Slackpull.	Three drums plus skyline
f) European	17&18	x	x		2,000	5,000	1-1/4-1-3/4	Wyssen, Baco	Single drum, Sled mounted
g) Long span	19,20							Self-contained	Two-drum plus skyline
	21,22	x	x		5,000	5,000	1-3/8-2	controlled by radio	

Table 9-1

SUMMARY OF CABLE SYSTEMS (Continued)

System	Fig.	Harv. Meth.			Yard. Dist.		Skyline Size (In.)	Carriage Type	Yarder Type
		9-	CC	OR	TH	UP (Ft)			
4. Running Skyline	23	x	x	x	1,000	600	5/8-1 1/8	Mechanical	Three-drum yarder (interlock or Wichita brakes)
a) Slackpulling Carriage					(2,000) ^{4/}	(1,000)			
b) Grapple	24	x			1,000	600	5/8-1 1/8	Grapple	Three-drum yarder (interlock or Wichita brakes)
					(2,000) ^{4/}	(1,000)			
c) Remote Grapple	25	x			1,500	600	3/4-1 1/2	Radio-Controlled Grapple	Two-drum yarder (interlock or Wichita brakes)
d) Grabinski	26	x			1,500	600	3/4-1 1/2	Butt rigging & Rider Block	Two-drum
5. Balloon									
a) Haulback	27	x			0	4,000	1	None	Two-drum interlock yarder
b) Inverted Skyline	28	x			0	4,000	1	Block	Two-drum interlock yarder

- 1/ Maximum yarding distance. The yarding distance will vary with cable capacity of the yarder and topography. External yarding distance is approximately 1/2 to 3/4 of the cable capacity of the yarder.
 - 2/ Can yard downhill with yarder at upper end. Turn must be yarded free of the ground.
 - 3/ This system can operate in a partial cut if a slackpulling carriage is used.
 - 4/ There are two running skyline systems which are capable of yarding 2,000 feet.
 - 5/ This is a ground lead system which utilizes a main line in place of a skyline.
- CC Clearcut.
 OR Overstory removal.
 TH Thinning

Table 9-1 (Cont.)

YARDERS

Highlead (Small 1-1/8" mainline or less)

Edco Portospar with Wildcat Yarder

335-hp Cummins diesel
1,350 feet of 1-1/8" mainline
3,050 feet of 3/4" haulback line
3,000 feet of 3/8" strawline
Line Speeds:
 1,100 ft/min (main drum, half drum)
 2,400 ft/min (haulback, half drum)

Line Pull:
 96,000 pounds (main drum)
75-foot fixed length tower (6-3/4" guys)
Yarder and tower mounted on truck chassis
Weight without lines: 74,600 pounds

Berger Marc I Tower-Yarder

300-hp engine
1,350 feet of 1-1/8" mainline
3,000 feet of 3/4" haulback line
3,500 feet of 3/8" strawline
Line Speeds:
 700 ft/min (main drum, Half drum, low gear)
 1,800 ft/min (haulback drum, half drum, high gear)
Line Pull:
 85,000 pounds (main drum, half drum, low gear)
 17,000 pounds (haulback drum, half drum, high gear)
50-foot fixed length tower (3 guys 660 feet of 7/8")
Undercarriage: D8 tractor
Weight without lines: 78,500 pounds

Berger M-1 Yarder

300-hp engine
1,350 feet of 1-1/8" mainline
3,000 feet of 3/4" haulback line
3,500 feet of 3/8" strawline
Line Speeds:
 160 ft/min (main drum, half full, low gear)
 1,800 ft/min (haulback drum, half fell, high gear)
Line Pulls:
 85,000 pounds (main drum, half full, low gear)
 17,000 pounds (haulback drum half full high gear)
Weight without lines: 21,000 pounds

Skagit BU-70

250-hp engine
1,325 feet of 1-1/8" mainline
3,550 feet of 3/4" haulback line
3,850 feet of 3/8" strawline

Wichita brakes

Optional skidding drum holds 1,500 feet of 7/8" line

This yarder is no longer manufactured.

Skookum K-75

250-350-hp engine

1,250 feet of 1-1/8" mainline

3,250 feet of 3/4" haulback line

3,450 feet of 3/8" strawline

Weight: 28,000 pounds

This yarder is no longer manufactured

Skookum K-105

150-300-hp engine

1,200 feet of 1" mainline

3,000 feet of 3/8" strawline

3,000 feet of 5/8 haulback line

Weight: 17,000 pounds

This yarder is no longer manufactured

Skookum-Tyee K-168

470-hp engine

1,300 feet of 1-1/8" mainline

3,200 feet of 3/4" haulback line

3,450 feet of 3/8" strawline

Line Speeds:

700 ft/min (main drum, half full)

2,000 ft/min (haulback drum, half full)

Line Pull:

65,000 pounds (main drum, half full, stall)

22,000 pounds (haulback drum, half full, stall)

Weight without lines: 35,000 pounds

Regenerative brakes

Truck-mounted undercarriage

Width (overall) 11 feet

75-foot or 90-foot spar

1-1/8" maximum main line

Total weight with yarder and lines: 104,800 pounds

Skagit SJ2-R Mobile Thinning Machine

1,000 feet of 3/4" skyline

1,000 feet of 5/8" skidding line

50-foot tower with two powered guyline drums

360° swing

Rubber tire undercarriage

Weight with lines: 50,000 pounds

Skagit SJ-4RT Mobile Yarder-Loader

840 feet of 3/4" mainline

1,900 feet of 1/2" haulback line

2,090 feet of 5/16" strawline

2 guylines

This yarder is no longer manufactured

Skagit SJ-5R Mobile Yarder-Loader

700 feet of 1" mainline
1,630 feet of 5/8" haulback line
2,500 feet of 5/16" strawline
2 guyline drums
Line Pull:
82,000 pounds (main drum)
16,200 pounds (haulback drum)
Line Speed:
730 ft/min (main drum)
1,960 ft/min (haulback drum)
This yarder is no longer manufactured

SJ-7R Mobile Yarder-Loader

1,000 feet of 1" mainline
2,200 feet of 5/8" haulback line
2,975 feet of 3/8" strawline
Four hydraulic outriggers
This yarder is no longer manufactured

Washington TL-15 Trakloader

900 feet of 1-1/8" mainline
1,700 feet of 5/8" haulback line
5,500 feet of 1" strawline
Line Speeds:
720 ft/min (mainline)
2,400 ft/min (haulback line)

Line Pulls:

98,000 pounds stall pull (mainline)
38,000 pounds stall pull (haulback line)

Washington TL-6 Trakloader

250-hp engine
800 feet of 1" mainline
1,140 feet of 3/4" haulback line
530 feet of 7/16" strawline
Line Speed:
1,230 ft/min (main drum)
1,230 ft/min (haulback drum full)

Line Pulls:

78,000 pounds (main drum, bare)
77,500 pounds (haulback drum, bare)

Width over outside tires: 10'9-3/4", outside tracks, 12'10"

Maximum gradeability: 24%

Weight without lines: 120,000 pounds

Madill 3-400

400-hp engine
1,650 feet of 1-1/8" mainline
3,600 feet of 3/4" haulback line
Mounted on self-propelled, rubber-tired undercarriage with a
75-foot fixed-length spar

Highlead (large, mainline larger than 1-1/8")

Berger L-2 Planet - Lok

450-hp engine
1,700 feet of 1-1/4" mainline
3,840 feet of 1" haulback line
4,500 feet of 7/16" strawline
This yarder is no longer manufactured

Berger M-2 Yarder

425-hp engine
1,750 feet of 1-3/8" mainline
4,000 feet of 7/8" haulback line
4,500 feet of 3/8" strawline
Line Speeds:
180 ft/min (main drum half full, low gear)
1,800 ft/min (haulback drum, half full, high gear)

Line Pulls:

105,000 pounds (main drum, half full, low gear)
14,500 pounds (haulback drum, half full high gear)

Weight of yarder without lines: 32,000 pounds

Optional skidding drum: 2,000 feet of 1" line

Berger Marc IV Tower-Yarder

The M-2 yarder mounted on a D9 tractor frame with a 110-foot telescoping tower and six guylines (360 feet of 1" line)

Total Weight, including lines: 160,000 pounds

Self-propelled

Berger Marc III Tower-Yarder

425-hp engine
1,400 feet of 1-1/4" mainline
4,000 feet of 3/4" haulback line
4,500 feet of 7/16" strawline
Line speeds:
180 ft/min (main drum, half full, low gear)
1,800 ft/min (haulback drum, half full, high gear)

Line Pulls:

110,000 pounds (main drum, half full, low gear)
24,000 pounds (haulback drum, half full, high gear)

90-foot tower (6 1" guys, 360 feet)

D8 undercarriage

Total weight with lines: 118,250 pounds

Berger Marc II

The M-2 yarder mounted on a rubber tire undercarriage with a 110-foot telescoping tower.

Total Weight: 102,000 pounds

Skagit BU-80C

350-hp engine

1,450 feet of 1-1/4" mainline

3,350 feet of 7/8" haulback line

2,750 feet of 7/16" strawline

Line Speeds:

412 ft/min (main drum, half full, 5th gear)

1,527 ft/min (haulback drum, half full, 5th gear)

Line Pulls:

96,400 pounds (main drum, half full, low gear, stall)

27,400 pounds (haulback drum, half full, low gear, stall)

Weight without lines: 25,000 pounds

Wichita brakes

Optional skidding drum holds 1,240 feet of 1" line

Skagit BU-84

450-hp engine

1,450 feet of 1-1/4" mainline

3,550 feet of 7/8" haulback line

3,800 feet of 7/16" strawline

Wichita brakes

Optional skidding drum holds 1,240 feet of 1" line

This yarder is no longer manufactured

Skagit BU-90

575-hp engine

1,350 feet of 1-3/8" mainline

3,580 feet of 7/8" haulback line

3,900 feet of 7/16" strawline

Weight without lines: 32,000 pounds

Skagit BU-90G

525-hp engine

1,650 feet of 1-3/8" mainline

4,000 feet of 7/8" haulback line

7,000 feet of 7/16" strawline

Weight without lines: 30,000 pounds

Designed for tropical logging

Skagit BU-94

450-hp engine

1,350 feet of 1-3/8" mainline

5,205 feet of 7/8" haulback line

3,890 feet of 7/16" strawline

Line Speeds:

401 ft/min (main drum, half full, 5th gear)

1,395 ft/min (Haulback drum, half full, 5th gear)

Line Pulls:

81,700 pounds (main drum, half full, low gear, stall)

32,900 pounds (haulback drum, half full, low gear, stall)

Weight without lines: 35,600 pounds

Wichita brakes

Skagit BU-99II

575-hp engine
1,750 feet of 1-3/8" mainline
4,680 feet of 7/8" haulback line
3,900 feet of 7/16" strawline
Weight without lines: 32,000 pounds

Skagit BU-99C

525-hp engine
2,000 feet of 1-3/8" mainline
5,000 feet of 7/8" haulback line
5,000 feet of 7/16" strawline
Weight without lines: 32,000 pounds
Designed for tropical logging

Skookum-Tyee K-168A

470-hp engine
1,050 feet of 1-1/4" mainline
2,350 feet of 7/8" haulback line
2,550 feet of 7/16" strawline
Line Speeds:
600 ft/min (main drum, half full)
1,800 ft/min (haulback drum, half full)

Line Pulls:

75,000 pounds (main drum, half full, stall)
25,000 pounds (haulback drum, half full, stall)

Weight without lines: 35,000 pounds

Regenerative brakes

Skookum-Tyee K-166

470-hp engine
1,300 feet of 1-3/8" mainline
3,200 feet of 7/8" haulback line
3,400 feet of 7/16" strawline
Line Speeds:
1,730 ft/min (main drum, half full, 5th gear)
3,500 ft/min (haulback drum, half full, 5th gear)

Line Pulls:

100,000 pounds (main drum, half full, low gear, stall)
48,000 pounds (haulback drum, half full, low gear, stall)

Weight without lines: 40,000 pounds

Regenerative brakes

Skookum-Tyee K-114A

450-550-hp engine
1,400 feet of 1-3/8" mainline
3,500 feet of 7/8" haulback line
3,400 feet of 7/16" straw line
Regenerative brakes
Optional skidding drum holds 1,800 feet of 1" line
This yarder is no longer manufactured

Skookum-Tyee K-65A

350-470-hp engine
1,400 feet of 1-3/8" mainline
3,500 feet of 7/8" haulback line
3,400 feet of 7/16" strawline
Regenerative brakes
Optional skidding drum holds 1,800 feet of 1" line
This yarder is no longer manufactured

Skookum K-65

350-450-hp engine
1,400 of 1-1/4" mainline
3,300 feet of 7/8" haulback line
3,400 feet of 7/16" strawline
Weight: 36,000 pounds
This yarder is no longer manufactured

Skookum K-75A

250-350-hp engine
1,250 feet of 1-1/4" mainline
3,200 feet of 3/4" haulback line
3,450 feet of 3/8" strawline
Weight: 30,000 pounds
This yarder is no longer manufactured

Washington 158

335-hp engine
1,470 feet of 1-1/4" mainline
3,600 feet of 1" haulback line
3,900 feet of 7/16" strawline
Interlock
Line Speeds:
 905 ft/min (main drum, half full, 4th gear)
 1,265 ft/min (haulback drum, half full, 4th gear)
Line pull:
 30,500 pounds (main drum, half full, low gear)
 21,900 pounds (haulback drum, half full, low gear)
This yarder is no longer manufactured

Washington 157

320-hp engine
1,500 feet of 1-1/4" mainline
3,400 feet of 7/8" haulback line
3,700 feet of 3/8" strawline
Line Speeds:
 930 ft/min (main drum, half full, high gear)
 2,540 ft/min (haulback drum, half full, high gear)
Line Pull:
 20,600 pounds (main drum, half full, low gear)
 4,950 pounds (haulback drum, half full, low gear)
Weight: 25,000 pounds
This yarder is no longer manufactured

Madill 3-500

300-550-hp engine
1,450 feet of 1-1/4" mainline
3,400 feet of 7/8" haulback line
3,500 feet of 3/8" strawline
Wichita brakes
Line Pull:
 97,000 pounds (main drum, half full)
 35,100 pounds (haulback drum, half full)
Line Speed:
 1,200 ft/min (main drum, half full)
 2,820 ft/min (haulback drum, half full)
Self-propelled model weighs 94,350 pounds with lines.

Madill 3-600

500-hp engine
1,580 feet of 1-1/2" mainline
4,000 feet of 1" haulback line
4,500 feet of 7/16" strawline
Line Speeds:
 1,570 ft/min (main drum, half full, high gear)
 3,340 ft/min (haulback drum, half full, high gear)
Line Pulls:
 121,000 pounds (main drum, half full, low gear, stall)
 57,000 pounds (haulback drum, half full, low gear, stall)
Weight without lines: 54,000 pounds

Lynnwood Porta-Tower 90

Manufactured by Lynnwood Equipment Company
90-foot square spar mounted on a crawler tractor such as a D9, TD-24, or
 an HD-19
1,200 feet of 1-3/8" mainline
3,000 feet of 3/4" haulback line
Equipped with 6 guyline drums
31 feet, overall length on a D9 tractor
Designed for a maximum of 1-3/8" mainline
Total weight: 117,000 pounds

Washington 208

500-hp engine
1,650 feet of 1-3/8" mainline
3,600 feet of 1" haulback line
4,000 feet of 7/16" strawline
Interlock
Line Speeds:
 1,415 ft/min (main drum, half full, 4th gear)
 2,060 ft/min (haulback drum, half full, 4th gear)
Line Pulls:
 34,400 pounds (main drum, half full, low gear)
 23,800 pounds (haulback drum, half full, low gear)
Weight: 35,500 pounds

Washington 207

430-hp engine

1,650 feet of 1-3/8" mainline

3,400 feet of 7/8" haulback line

3,900 feet of 7/16" strawline

Line Speeds:

905 ft/min (main drum, half full, high gear)

2,320 ft/min (haulback drum, half full, high gear)

Line Pulls:

36,600 pounds (main drum, half full, low gear)

7,600 pounds (haulback drum, half full, low gear)

Weight: 28,000 pounds

Slackline

Madill 071 (West Coast Tower)

220-hp engine
1,930 feet of 1" skyline
1,885 feet of 5/8" mainline
4,200 feet of 1/2" haulback line
1,900 feet of 3/8" strawline
Wichita brakes on haulback and main drums
Main line pull: 6,700 pounds
Main line speed: 2,120 ft/min (3rd gear)
49-foot tower
4 guylines
Track undercarriage (Terex C-6)
Weight without lines: 72,780 pounds

Madill 5-500

550-hp engine
1,850 feet of 1-3/8" skyline
2,000 feet of 1-1/8" mainline
4,000 feet of 1" haulback line
4,500 feet of 7/16" strawline (2 strawline drums)
Wichita brakes
Line Speeds:
2,900 ft/min (mainline, high gear)
4,100 ft/min (haulback line, high gear)
Line Pulls:
76,000 pounds (mainline, low gear)
54,000 pounds (haulback line, low gear)

Skagit BU-98

450-hp engine
1,700 feet of 1-1/2" skyline
1,350 feet of 1-3/8" mainline
5,000 feet of 7/8" haulback line
4,000 feet of 7/16" strawline
Line Speeds:
474 ft/min (skyline drum, half full, 5th gear)
460 ft/min (main drum, half full, 5th gear)
1,755 ft/min (haulback drum, half full, 5th gear)
Line Pulls:
78,900 pounds (skyline drum, half full, low gear, stall)
87,600 pounds (main drum, half full, low gear, stall)
32,000 pounds (haulback drum, half full, low gear, stall)
Weight without lines: 51,000 pounds
Wichita brakes on main and haulback drums

Skagit BU-99

635-hp engine

2,420 feet of 1-1/2" skyline

1,780 feet of 1-3/8" mainline

5,410 feet of 7/8" haulback line

7,529 feet of 7/16" strawline

Line Speeds:

857 ft/min (skyline drum, half full, 6th gear)

884 ft/min (main drum, half full, 6th gear)

1,842 ft/min (haulback drum, half full, 6th gear)

Line Pulls:

84,800 pounds (skyline drum, half full, low gear, stall)

85,300 pounds (main drum, half full, low gear, stall)

40,900 pounds (haulback drum, half full, low gear, stall)

Weight without lines: 52,000 pounds

Wichita brakes on main and haulback drums

Washington 208E

500-hp engine

1,650 feet of 1-3/8" skyline

2,000 feet of 1-1/4" mainline

3,600 feet of 1" haulback line

4,000 feet of 7/16" strawline

Line Speeds:

1,392 ft/min (skyline drum, half full, 4th gear)

1,364 ft/min (main drum, half full, 4th gear)

1,950 ft/min (haulback drum, half full, 4th gear)

Line Pulls:

270,000 pounds (skyline drum, empty, low gear, stall)

270,000 pounds (main drum, empty, low gear, stall)

190,000 pounds (haulback drum, empty, low gear, stall)

Weight with self-propelled, 110-foot spar, lines and fuel: 182,200 pounds

Washington 217D

525-hp engine

2,650 feet of 1-1/2" skyline

2,020 feet of 1-3/8" mainline

4,700 feet of 7/8" haulback line

3,900 feet of 7/16" strawline

Line Speeds:

1,056 ft/min (skyline drum, half full, 5th gear)

1,500 ft/min (main drum, half full, 5th gear)

2,274 ft/min (haulback drum, half full, 5th gear)

Line Pulls:

348,900 pounds (skyline drum, empty, low gear, stall)

228,500 pounds (main drum, empty, low gear, stall)

168,000 pounds (haulback drum, empty, low gear, stall)

Weight with 110-foot self-propelled undercarriage with fuel and lines:

212,000 pounds

Skookum-Tyee 114CS

- 460-hp engine
- 1,700 feet of 1-3/8" skyline
- 2,200 feet of 1" mainline
- 4,200 feet of 7/8" haulback line
- 6,300 feet of 7/16" strawline

Line Speeds:

- 1,400 ft/min (skyline drum, half full, 5th gear)
- 1,350 ft/min (mainline drum, half full, 5th gear)
- 4,300 ft/min (haulback drum, half full, 5th gear)

Line Pulls:

- 125,000 pounds (skyline drum, half full, low gear, stall)
- 72,000 pounds (mainline drum, half full, 2nd gear, stall)
- 40,000 pounds (haulback drum, half full low gear, stall)

Skookum-Tyee K-177

- 318-hp engine
- 1,200 feet of 1" skyline
- 1,400 feet of 3/4" mainline
- 3,100 feet of 5/8" haulback line
- 3,000 feet of 3/8" strawline

Line Speeds:

- 2,500 ft/min (skyline drum, half full, 5th gear)
- 2,500 ft/min (main drum, half full, 5th gear)
- 4,600 ft/min (haulback drum, half full, 5th gear)

Line Pulls:

- 61,000 pounds (skyline drum, half full, 1st gear, stall)
- 35,000 pounds (main drum, half full, 2nd gear, stall)
- 33,000 pounds (haulback drum, half full, 1st gear stall)

Weight without lines: 25,000 pounds

Regenerative brakes

Timber Tower

Undercarriage: Timberjack 404 wheel skidder with dual wheels on rear axle

- Yarder: 1,600 feet of 7/8" or 1,250 feet of 1" skyline
 1,700 feet of 5/8" mainline
 2,300 feet of 5/8" haulback line

Tower: 55-foot, one-piece with 4 power guyline drums holding 300 feet of 1" line

Running Skyline

Berger Planet-Lok L-1

300-hp engine
2,200 feet of 7/8" mainline
2,300 feet of 5/8" slackpulling line
4,400 feet of 7/8" haulback line
4,500 feet of 7/16" strawline
Line Speeds:
 425 ft/min (main drum, half full, low gear)
 1,800 ft/min (haulback drum, half full, high gear)
Line Pulls:
 62,000 pounds (main drum, half full, low gear)
 29,000 pounds (haulback drum, half full, high gear)
Yarder weight with line: 42,000 pounds
May be mounted on a Marc I, self-propelled tower

Washington 108 Skylok

315-hp diesel engine
Two mainline drums holding 1,100 feet of 7/8" line each
2,200 feet of 3/4" haulback line
2,300 feet of 3/8" strawline
Line Speeds:
 1,730 ft/min (haulback drum, full)
 1,300 ft/min (main drum, full)
Line Pulls:
 24,700 pounds (haulback drum, empty)
 96,000 pounds (main drum, empty)
2 guyline drums
50-foot swing boom
Weight with lines and fuel: 106,600 pounds
Gradeability: 25%
Crawler or rubber-tired undercarriage

Washington 98 Skylok

180-hp diesel engine
Two mainline drums holding 1,000 feet of 5/8" line each
2,100 feet of 3/4" haulback line
Line Speed: 900 ft/min
45-foot swinging boom
This yarder is no longer manufactured

Washington 78 Skylok

185-hp diesel engine
Two mainline drums holding 1,200 feet of 5/8" line each
2,250 feet of 3/4" haulback line
2,400 feet of 5/16" strawline
Line Speeds:
 1,502 ft/min (haulback drum, full)
 1,350 ft/min (main drum, full)
Line Pulls:
 17,000 pounds (haulback drum, empty)
 52,600 pounds (main drum empty)
2 guyline drums containing 150 feet of 3/4" line each

Weight lines and fuel: 88,500 pounds
37-foot swinging boom
Track width: 11' 2"

Skagit GT-5

320-hp engine
Two mainline drums hold 1,100 feet of 1" line each
2,200 feet of 1" haulback line
2,780 feet of 3/8" strawline
55-foot swinging boom
Wichita water-cooled brakes on all drums
Approximate weight: 153,000 pounds

Skagit GT-4

320-hp engine
Side-by-side mainline drums each holding 1,000 feet of 7/8" line
2,600 feet of 7/8" haulback line
2,700 feet of 7/16" strawline
Line Speeds:
1,691 ft/min (haulback drum, half full, 5th gear)
987 ft/min (main drum, half full, 5th gear)
Line Pulls:
56,300 pounds (haulback drum, half full, low gear, stall)
96,500 pounds (main drums, half full, low gear, stall)
55-foot swing boom
Track undercarriage, 13' 1/2" overall width
Mechanical interlock (air clutches)
Weight with lines: 144,600 pounds

Skagit GT-3 Grapple Yarder

220-hp engine
Two side-by-side mainline drums hold 1,200 feet of 5/8" line each
2,200 feet of 3/4" haulback line
3,200 feet of 3/8" strawline
140 feet of 7/8" guyline
Line Speeds:
1,410 ft/min (main drums, full)
2,275 ft/min (haulback drum, full)
Line Pulls:
71,000 pounds (main drums, empty)
35,700 pounds (haulback drum, empty)
44-foot swinging boom
Track undercarriage - 12'6" overall width
Weight without lines: 95,040 pounds
30% gradeability
Mechanical interlock on haulback and main drums

Madill 6-500

535-hp diesel engine
1,760 feet of 1" mainline
2,300 feet of 7/8" haulback line
1,400 feet of 5/8" tagline

Madill 052

535-hp engine
4,100 feet of 1-1/8" haulback line
2,300 feet of 1-1/8" mainline
2,200 feet of 1" slackpulling line
6,000 feet of 7/16" strawline
90-foot steel tower
Weight: 185,000 pounds

European Yarders

Unimog-Urus 300-2.5

100-hp engine
1,148 feet of 1/2" mainline
2,133 feet of 1/2" haulback line
985 feet of 7/8" skyline
2,297 feet of 3/16" strawline
Mainline Pull: 5,500 pounds average
Tower Height: 28-1/2'
Three Guys: 164 feet of 3/4"
Mounted on Mercedes-Benz truck
Total Weight: 14,630 pounds

Baco SWU 40L

90-hp engine
7,218 feet of 7/16" mainline
Brakes: Air fan
Traction Power: 11,000 pounds
Working Speeds:
 uphill 26 ft/sec.
 downhill 40 ft/sec.
Weight: 4,851 pounds
Sled-mounted

Baco SWU 80L

150-hp engine
6,562 feet of 5/8" mainline
Brakes: Air fan
Traction Power: 17,800 pounds
Working Speeds:
 uphill 26 ft/sec.
 downhill 40 ft/sec.
Weight: 6,615 pounds
Sled-mounted

Baco SWU 125L

320-hp engine
7,218 feet of 7/8" mainline
Brakes: Air fan
Traction Power: 33,400 pounds
Working Speeds:
 uphill 26 ft/sec.
 downhill 40 ft/sec.
Weight: 17,640 pounds

Wyssen W-30

42-hp engine
5,400 feet of 7/16" mainline
Brakes: Air fan and friction
Load Capacity: 4,400 pounds
Weight: 2,700 pounds
Sled-mounted

Wyssen W-30
42-hp engine
5,400 feet of 7/16" mainline
Brakes: Air fan and friction
Load Capacity: 4,400 pounds
Weight: 2,700 pounds
Sled-mounted

Wyssen W-30
80-hp engine
7,200 feet of 7/8" mainline
Brakes: Air fan and friction
Load Capacity: 11,000 pounds
Weight: 4,000 pounds
Sled-mounted

Wyssen W-300
300-hp engine
7,200 feet of 1" mainline
Brakes: Air fan and friction
Load Capacity: 36,400 pounds
Weight: 12,000 pounds
Sled-mounted

Wyssen W-60

53-hp engine
3,100 feet of 5/8" mainline
Brakes: Air fan and friction
Load Capacity: 11,000 pounds
Weight: 3,700 pounds
Sled-mounted

Wyssen W-90

80-hp engine
5,900 feet of 5/8" mainline
Brakes: Air fan and friction
Load Capacity: 11,000 pounds
Weight: 4,000 pounds
Sled-mounted

Wyssen W-200

200-hp engine
5,200 feet of 1" mainline
Brakes: Air fan and friction
Load Capacity: 26,400 pounds
Weight: 15,000 pounds
Sled-mounted

OTHER YARDERS

Manufac.-Model High Lead (2 Drum)	Lines - Size and Length						Yarder				Comments
	Skyline	Mainline	Haulback		Straw		Weight	Length		Width	
	Diam," Lgth'	Diam," Lgth'	Diam," Lgth'	Diam," Lgth'	Diam," Lgth'	Diam," Lgth'	Lbs.	Ft.-In.	Ft., In	Ft., In	
Skagit BU-15		3/4 595	7/16 1,750	5/16 650	5,400	6 10	5 0				
Skagit BU-20		3/4 100	7/16 2,650	1/4 2,950	9,100	7 6	6 0				
Skagit BU-30		1 850	5/8 1,850	3/8 3,000	10,500	9 1	7 2				
Skagit BU-50		1 1,050	5/8 2,250	3/8 3,050	11,800	9 1	7 6				
Skagit BU-75		1-1/8 1,000	5/8 2,700	3/8 3,500	14,500	10 5	7 10				
Skagit BU-85		1-1/8 1,200	5/8 3,450	3/8 3,050	14,500	10 0	7 10				
Skagit BU-100		1-1/4 1,000	3/4 2,300	3/8 3,500	17,300	10 11	8 2				
Skagit BU-125		1-1/4 1,440	3/4 3,000	3/8 3,600	18,260	11 3	8 6				
Skagit BX-130		1-1/4 1,440	3/4 3,000	3/8 3,600	25,000	12 3	8 11				
Skagit BU-135		1-3/8 1,250	7/8 2,500	3/8 3,600	19,800	11 9	8 10				
Skagit BX-140		1-3/8 1,350	7/8 2,500	3/8 3,600	27,000	12 6	9 0				
Skagit BX-200		1-1/2 1,560	7/8 4,000	3/8 4,560	42,000	13 6	10 2				
Skagit BX-300		1-1/2 1,690	1 3,700	7/16 5,000	58,000	17 0	10 7				
Skagit BX-500		1-5/8 1,770	1 4,400	7/16 5,000	67,000	20 6	11 0				
Skagit IJ-80		1-1/4 1,550	7/8 3,160	7/16 4,330	37,500	14 4	12 3				Interlock
Skagit IJ-90		1-3/8 1,560	1 3,000	7/16 4,330	40,000	14 10	12 3				Interlock
Skagit PT-4-Y		1-1/8 1,300	3/4 2,900	5/16 3,200	45,000						

Table 9-2

Manuf. -Model Slackline (3 drum)	Lines - Sizes and Length								Yarder				Comments	
	Skyline		Mainline		Haulback		Straw		Weight	Length		Width		
	Diam"	Lgth'	Diam"	Lgth'	Diam"	Lgth'	Diam"	lgth"	Lbs.	Ft.	In.	Ft.		In.
Skagit BU-70	1-1/8	1,325	7/8	1,500	3/4	3,350	3/8	3,850	18,000	11	0	10	3	Wichita Brakes
Skagit BU-80	1-1/4	1,450	1	1,240	7/8	3,350	7/16	2,750	25,000	12	2	11	0	Wichita Brakes
Skagit BU-90	1-3/8	1,350	1-1/8	1,200	7/8	3,580	7/16	3,250	30,500	13	10	10	6	Wichita Brakes
Skagit BU-95	1-3/8	1,800	1-1/8	1,500	7/8	4,680	1/2	2,980	32,000	13	10	11	2	Wichita Brakes
Skagit BU-97	1-1/2	2,000	1-1/4	1,470	1	3,580	9/16	2,700	34,000	14	0	11	6	Wichita Brakes

Table 9-2
Continued

TOWERS AND UNDERCARRIAGES

Yarders, towers and undercarriages are sold in various combinations. Some manufacturers list the components separately (yarder, tower undercarriage and options) from which a "package" can be made to meet the purchaser's needs. Other manufacturers provide the "package" as an integral piece of equipment. Most provide options of trailer-mounting, self-propelled, rubber-tires, or self-propelled crawler mounted undercarriage.

Towers are offered in lengths ranging from 45 to 120 feet. Some are fixed-length and others telescope. Towers may be standard duty (for highlead) or heavy duty (for skylines). Usually, a seventh or eighth guyline is recommended. Guyline drums are considered part of the tower and the guylines and raising or hoisting lines are generally provided with the tower.

Some of the manufacturers provide the option of an underslung or third fairlead on the tower for use as a shotgun or flyer. A brief description of the towers and undercarriages offered by the equipment manufacturers follows:

The Skookum undercarriage is track-mounted and the spars are solid or fixed-length tubes. The lengths and maximum size line are as follows:

<u>Model</u>	<u>Length</u>	<u>Line Size</u>	<u>Weight</u>
S	90 Feet	1-3/8"	70,000 lbs.
E	75 or 90 feet	1-1/8"	63,300 lbs.
J	60 feet	1"	
M	45 feet	7/8"	

Width outside of tracks is 11 feet

Madill manufactures a 90-foot solid spar that may be mounted on a self-propelled rubber-tired or truck undercarriage. Maximum line size is 1-3/8-inch.

Smith-Berger manufactures the following towers and undercarriages:

Trailer Mounted Teletower 80/90 feet

Tower height: 80 feet or 90 feet (6 guys)

Optional 3rd fairlead for skyline yarding

Maximum line size: 1-1/4"

Guyline drum capacity: 360 feet of 1"

Weights:

Tower 80-90 feet 26,400/27,400 pounds

Trailer 24,000 pounds

M-3 yarder (with 10,000 pounds of lines) 40,000 pounds

Trailer Mounted Teletower 100/110 feet

Wheelbase: 18' 1"

Optional 7th and 8th guyline drums

Optional 3rd fairlead for skyline yarding

Maximum line size: 1-3/8"

Guyline drum capacity: 360 feet of 1"

Weights:

Standard tower with guylines 100/110 feet	42,700/46,500 pounds
Trailer with M-2 Yarder and lines	70,000 pounds
Tower with all options and guylines 100/110 feet	47,700/51,500 pounds

Skagit towers and undercarriages are as follows:

Model	Max. line size (inches)		No. of Guys	Weight HD tower (lbs)*	
	Stand. Duty	Heavy Duty		Trailer mounted	Self-propelled
T-90	1-1/4		6	46,000	60,000
T-100	1-1/4	1-3/8	6	63,240	98,000
T-110	1-3/8	1-1/2	6-8	86,080	104,000
T-120	1-3/8	1-1/2	6-8		

* Weights are without yarder

The weights shown under self-propelled are for rubber-tired undercarriages. Towers may also be mounted on tracks.

The Skagit Mini Tower can be mounted on a truck or trailer. The 50-foot non-telescoping tower has six guyline drums holding 120 feet of 1-1/8-inch line. The maximum line size for the tower is 1 inch.

Washington Iron Works' standard spar is a 110-foot telescoping tube mounted on a rubber-tired, self-propelled undercarriage. Maximum line size is 1-3/8-inch. The spar and undercarriage with eight guylines, fuel and lines, weighs approximately 182,200 pounds.

Gradeability in the self-propelled, rubber-tired carriers is 25% and the minimum turning radius is approximately 50 feet. For dimensions of the tower and undercarriage, consult equipment brochures.

SKYLINE CARRIAGES

A skyline carriage is a wheeled device which rides back and forth on the skyline for yarding. A skyline-crane carriage is the same as a skyline carriage, but it also provides a means for slackpulling and lateral skidding to the carriage.

Skyline carriages fall into two basic classes: Clamping and non-clamping. This basic subdivision is needed to identify which method should be used to determine the load-carrying capability of a skyline.

ClampingNon-Clamping

Rud-O-Matic	Shotgun or Flyer
Western Flyer	Berger Models C-1 thru C-6
RCC-20 Skycar	Slackline
RCC-15 Torpedo	North Bend
RCC-13 Tracer	South Bend
RCC-10 Bullet	Skidder
Hydro	Skyflyer
RCC-24	West Coast
Ross	Wheel
Young HR-300	McAllister Block
Wyssen	Noffsinger
Baco	Running Skyling
	Snapper
	Mechanical Grapple
	Shuttlebug

Skyline carriages may also be classified as grapple, non-slackpulling, and slackpulling.

Grapple: The design of this carriage is similar to some of the mechanical slackpulling carriages in that they must provide a means to open or close the grapple. This can be done with a line from the yarder or by using an engine or power device in the carriage. The grapple carriage cannot yard laterally unless it is sideblocked; therefore, it is often classified as non-slackpulling carriage.

Non-slackpulling: This type of carriage has no means of allowing a skidding line to be contained or pass through it. It may be moved laterally with a dutchman line or by sideblocking. The chokers usually are shackled directly to the carriage.

Slackpulling: This type of carriage can pull slack in the skidding line or have the skidding line pulled through it either by hand or mechanically. The carriage may be further classified as to how the slack is actually pulled:

Slackpulled by hand. In this type of carriage, the mainline passes through the carriage and becomes the skidding line. The carriage, after it is clamped to the skyline, acts as a block through which the mainline is pulled by the man in the brush. A slack-kicker may be used on the yarder to help strip

line from the drum. The carriage is usually manually-clamped.

Slackpulled by yarder. This type of carriage is designed so that the slackpulling line from the yarder pulls the skidding line out of the carriage. The skidding line may be contained on a drum in the carriage, or it may be attached to the mainline from the yarder. The carriage may have a radio-controlled clamp.

Slackpulled by carriage. This type of carriage uses some type of power device in the carriage for pulling slack. The power may be in the form of mechanical springs, hydraulic motors, or diesel or propane-fueled engines. The carriage will clamp to the skyline and is remotely-controlled by radio.

The following table lists the carriages in the above categories. All of the carriages listed rely on either the yarder or on gravity for their moving force. None are self-propelled.

GRAPPLE CARRIAGES

Carriage	Weight (lbs.)	Skyline Size (inches)	Clamps During Lateral Yarding	Haul-back Req'd	Yard. Direct. System					Remarks
					U.hill	D.hill	Live	Stand	Run	
Johnson Y84	2,400	1-1/4		Yes	x	x			x	Power Closing
Johnson Y66	1,550	1		Yes	x	x			x	Power Closing
Mar 303	1,700	3/4 - 1		Yes	x	x			x	
Mar 803	2,000	3/4-1-3/8		Yes	x	x			x	
Snapper	5,000	1-1/4-1-1/2			x	x	x		x	Radio-Controlled Grapple Rotates
Skagit RCC-24	9,000	1-3/8-1-1/2	Radio-Controlled		x	x	x			No longer mafd.
Skagit Grapple	1,200	3/4 - 1		Yes	x	x			x	Shamley Carr.
Washington Shriver	4,200	1-1/4-1-1/2			x	x	x		x	No longer mafd.
Young YD-60	1,550	7/8		Yes	x	x			x	Power Closing
Young YG-80	1,950	1		Yes	x	x			x	Power Closing

Table 9-3

NON-SLACKPULLING CARRIAGES

Carriage	Weight (lbs.)	Skyline Size (inches)	Clamps Dur. Lat. Yard.	Haul- back Req'd	Yard, Direct.		System			Remarks
					Uphill	Downhill	Live	Stand	Run	
Acme Model A	3,100				x	<u>1</u> /	x			Shotgun w/gooseneck
Acme Model B	3,000				x	<u>1</u> /	x			Shotgun
Berger C-5	2,870	1-3/8			x	<u>1</u> /	x			(Drift) Shotgun or Slackline
Forester 100	2,400	1-3/8			x	<u>1</u> /	x			Shotgun
Forester 86	1,800	1			x	<u>1</u> /	x			Shotgun
North Bend	1,500	1½ - 1½		Yes	x				x	
South Bend	2,000	1½ - 1½		Yes	x	x			x	
Skagit Sky Skooter	3,300	1-3/8			x	<u>1</u> /	x			Shotgun, will pass shackle
Skookum GO-16W	3,000	1-3/8			x	<u>1</u> /	x			Shotgun, will pass shackle
Skookum GO-18	2,750	1-3/8			x	<u>1</u> /	x			Shotgun
Skookum SGN-16W	1,950	1½ - 1½		Yes	x	x	x			Slackline, will pass shackle

1/ The shotgun system may be used to snub the turn downhill if the logs can be suspended free of the ground.

Table 9-4

SLACKPULLING CARRIAGES

Carriage	Weight Lbs	Skyline Size (inches)	Clamps During Lateral Yarding	Haul- back Req'd	Yard. Direc.		System			Remarks
					U.hill	D.hill	Live	stand	run	
<u>I Slackpulled by Hand</u>										
Baco	1,000	1-1/2	Mechan. Clamp			x		x		Carriage cycles
McAllister Block	200	5/8-1-1/8	Lays on ground		x			x		
Noffsinger	500	3/4-1-1/8	With strap			x		x		Carriage cycles
Ross	900	5/8-1-1/8	Manually		x			x		Needs slack kicker on yarder
Skagit Wheel	275	3/4-1-1/8	Stop on Skyline		x			x		
Western Flyer BB	1,200	5/8-3/4	Manually		x			x		
Western Flyer HW	1,500	7/8	Manually		x			x		
Western Flyer DG	1,800	1-1-1/8	Manually		x			x		
Wyssen	1,000	1-1/2	Hyd. Clamp.			x			x	Carriage Cycles
<u>II Slackpulled by Yarder</u>										
Baco (Endless line)	3,000	1-1/2	Clamps	Yes	x	x		x		Carriage cycles
Berger C-1	570	1-1/8		Yes	x	x		x		Skidder
Berger C-2	825	1-3/8		Yes	x	x		x		Skidder
Berger C-3	850	7/8		Yes	x	x			x	

Table 9-5

SLACKPULLING CARRIAGES

188

Carriage	Weight Lbs	Skyline Size (inches)	Clamps During Lateral Yarding	Haul- back Re'd	Yard. Direc.		System			Remarks
					U.hill	D.hill	Live	stand	run	
Berger C-4	1,300	1-1/2		Yes	x	x		x		Skidder
Berger C-6	3,000	1-3/8		Yes	x			x		Skidder (Multiple- Use Carriage)
Madill 052	3,800	1-1/8		Yes	x	x			x	Stores 450' of 7/8" skidding line
Pape Shuttle Bug	1,300	7/8		Yes	x	x	x	x	x	Stores 200' of 5/8" skidding line
Wash. Skyflyer	7,000	3/4		Yes	x	x		x		Stores 400' of 3/4" skidding line
West Coast	1,430	1-1-1/8		Yes	x	x	x	x		Stores 235' of 3/4" skidding line
Young YCC-13	450	3/4		Yes	x	x			x	
Young HR-300	3,500	1-1/8-1-1/2	Hydraulic clamp	Yes	x	x	x	x		
<u>III Slackpulled by Carriage</u>										
Rud-O-Matic	1,500	1-1-1/8	Spring clamp	Yes	x			x		Springs in carr. pull slack
Skagit RCC-20 Skycar	9,000	1-3/8-2	Hydraulic clamp	No	x	x	x	x		Radio-cont. diesel engine
" RCC-15 Torpedo	6,900	1-3/8-2	Hydraulic clamp	No	x	x	x	x		Radio-cont. diesel engine
" RCC-15 Tracer	3,200	1-1-1/2	Hydraulic clamp	No	x		x	x		Propane eng. 7/8" skidding line
" RCC-10 Bullet	3,000	1-1-1/2	Hydraulic clamp	No	x		x	x		Propane eng. 3/4" skidding line
" Hydro	2,000	7/8-1-1/4	Hydraulic clamp	No	x		x	x		Hydraulic motor

Table 9-5 (Cont'd)

A brief description of some of the more common carriages follows:

1. Shotgun (Flyer): This type of carriage is built by a number of manufacturers and can also be shop-built. Steelplate ballasts the carriage for gravity return. Four chokers are normally attached to the carriage. The yarder must have a live skyline drum, preferably one that will allow inhaul, raising the skyline at the same time. Lateral capability is restricted to the choker length and is accomplished by moving skyline anchorpoints. Yarding is uphill only (figure 9-6).

2. Slackline: This carriage is a frame which houses one or two wheels and provides attachment points for haulback, mainline and chokers. The carriage must be lowered to the ground each cycle to allow choker setting. Lateral capability is obtained by pulling the carriage to the side with the haulback line (figure 9-7).

3. North Bend: A carriage which acts as an attachment point for the mainline. The mainline passes through a fall block. Haulback and chokers are in turn attached to the fall block. The carriage operates on a standing skyline. Lateral skidding is accomplished by side-blocking (figure 9-12).

4. South Bend: A South Bend is similar to a North Bend except that the mainline passes through a block on the carriage, then through a fall block, and dead-ends on the carriage. South Bend systems are used downhill and the block purchase provides a means of keeping the logs from running ahead of the carriage. (figure 9-13).

5. Ross or Western Flyer: This carriage is used in thinning operations. Yarding is uphill. Skyline must be live. Slackpulling is manual (hand clamp) (figure 9-29).

6. West Coast: This is a slackpulling carriage which consists of three drums on a single axle. The mainline and skidding line are over-wound while the slackpulling line is under-wound. While the haulback holds the carriage in position, the slackpulling line pays out the skidding line (figure 9-30).

7. Young HR-300: This has three drums similar to the West Coast; however, the mainline, haulback and skidding lines are all over-wound. In addition, it has a skyline clamp and a drum brake, one of which is always clamped (figure 9-31).

8. Skidder: One of the oldest skyline carriages. It was used extensively in railroad logging. This carriage usually operates on a standing skyline and requires a main and haulback line. Slackpulling is accomplished with a small line passing through the carriage and fastened to the mainline. By pulling in on this slackpulling line, a segment of mainline passes through the carriage.

9. Rud-O-Matic Slackpulling Carriage: This carriage resembles the skidder but has a spring arrangement in the carriage that operates the slackpulling line. The haulback operates a skyline clamp which holds the carriage in place when slack is pulled in the mainline. The carriage is effective on uphill yarding only (figure 9-32).

10. Wyssen: This carriage has a programmed cycle which is activated by pulling on the main or operating line. During each cycle the carriage clamps to the skyline at the point of loading and landing. Hydraulic and spring tension operates the skyline clamp. Slackpulling is manual.

11. Baco: Same basic function as Wyssen but completely mechanical in operation. Slackpulling is manual.

12. Skyflyer: A carriage with a skidding-line drum which is geared to a drum around which a continuous mainline is wrapped. These mainlines control the skidding-line drum by pulling one in, the other out. This rotates the skidding-line drum causing the skidding line to increase or decrease in length. A yarder with interlocking main and haulback drums is needed for operation (figure 9-33).

13. RCC-20: Radio-controlled carriage. This carriage has a 96-hp diesel engine which is geared to a skidding line drum. The carriage is controlled by radio signal. Radio transmitters are used at the choker setting point and at the landing. This carriage will pass intermediate supports on multi-span skylines.

14. RCC-15: Same as RCC-20, but the carriage will not pass intermediate supports (figure 9-34).

15. RCC-13: Radio-controlled carriage. This carriage contains an air-cooled, 24-hp butane engine which drives a set of tramping drums for pulling slack. Lateral yarding is done with the mainline and yarder power. The carriage clamps to the skyline and operates with uphill yarding only. Carriage outhaul is accomplished by letting the carriage return by gravity (figure 9-35).

16. RCC-10: Bullet. Same as RCC-13 but uses 3/4-inch mainline instead of 7/8-inch.

17. McAllister Block: Resembles two blocks fixed back to back. Utilizes gravity to return the mainline and tongs or chokers.

18. Hydro-Carriage: Functions similar to the RCC-10 but uses hydraulic pressure, rather than an engine, to pull slack.

19. Washington Shriver: A remote-controlled grapple carriage that utilizes springs to open the grapple when the weight is removed from the tongs (figure 9-36).

20. Running Skyline Grapple: The haulback line controls the carriage while the two mainlines operate the grapples. A yarder with an interlock system facilitates the operation (figure 9-37).

ROSS or WESTERN FLYER

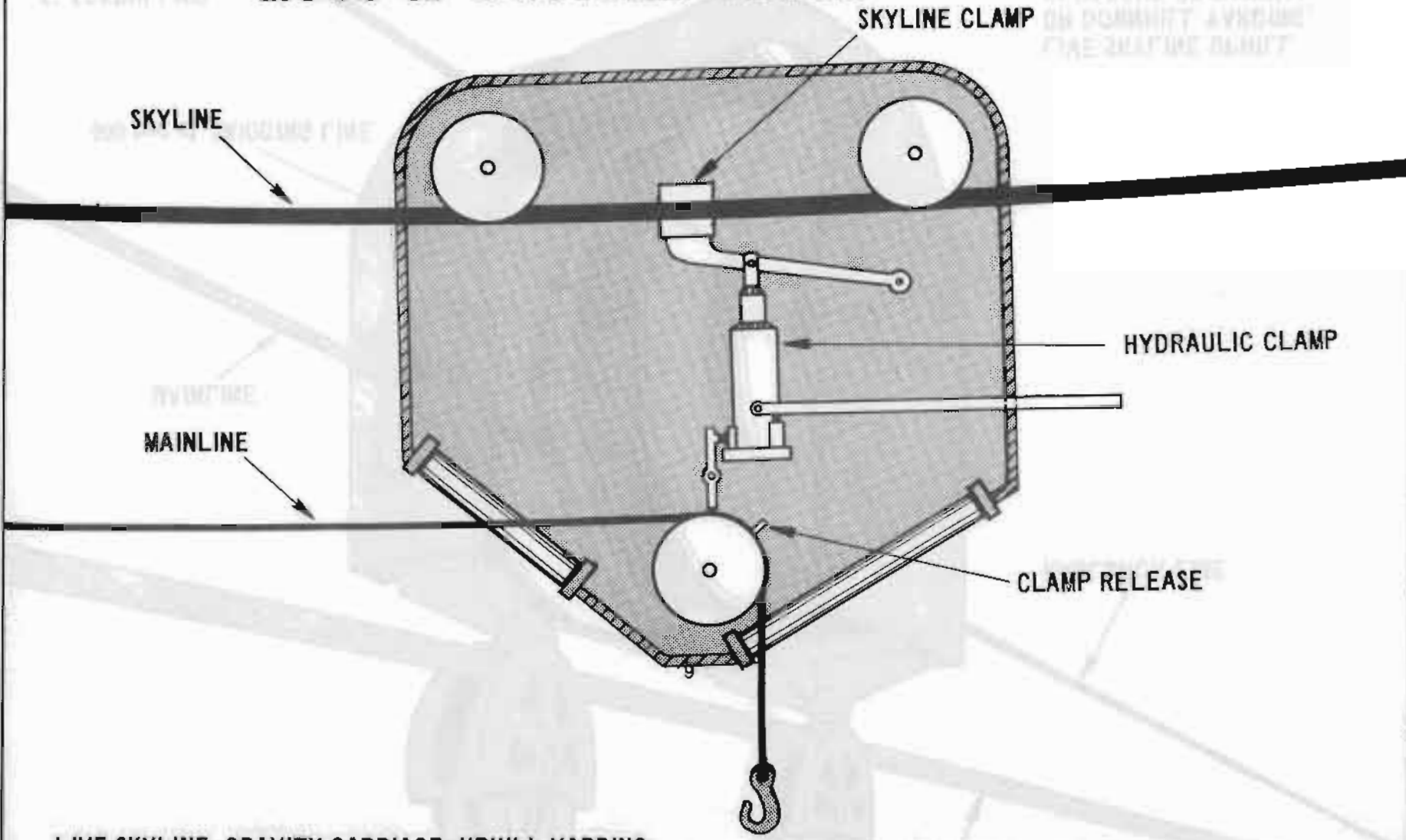

LIVE SKYLINE, GRAVITY CARRIAGE, UPHILL YARDING,
THINNING OR PARTIAL CUTTING.

Figure 9-29

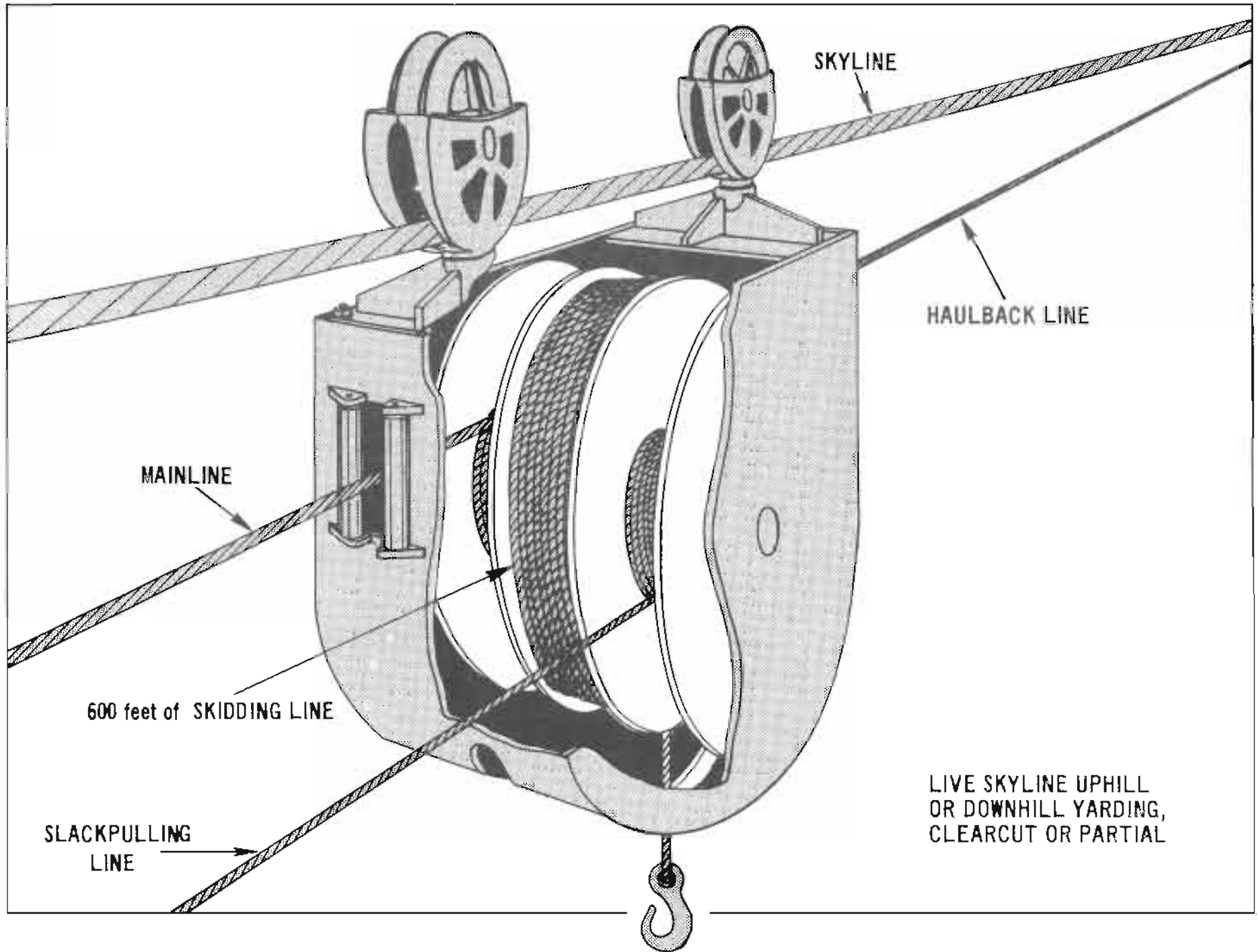

Figure 9-30



YOUNG HR-300

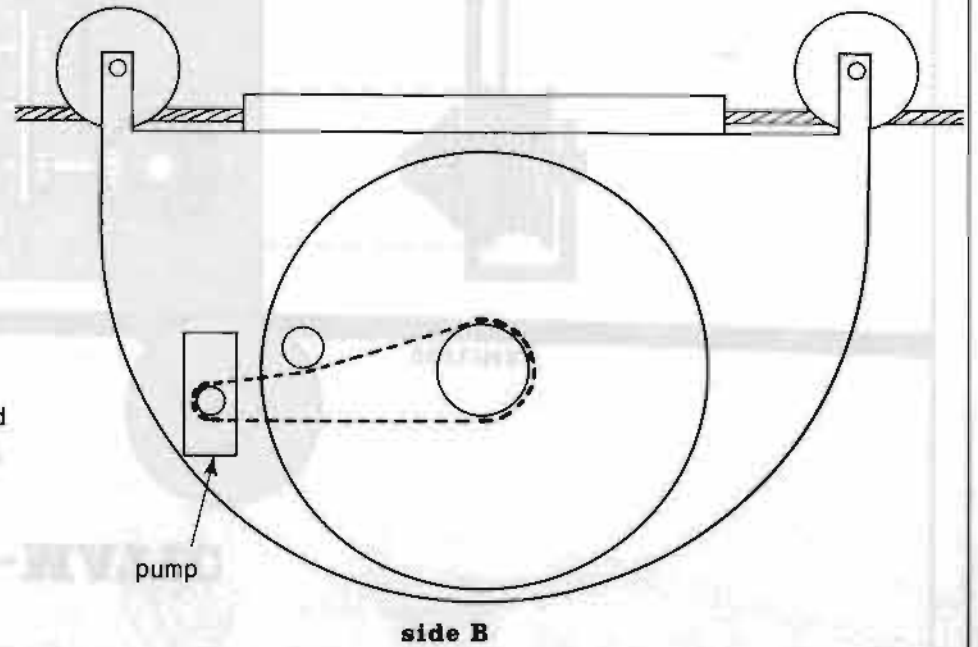
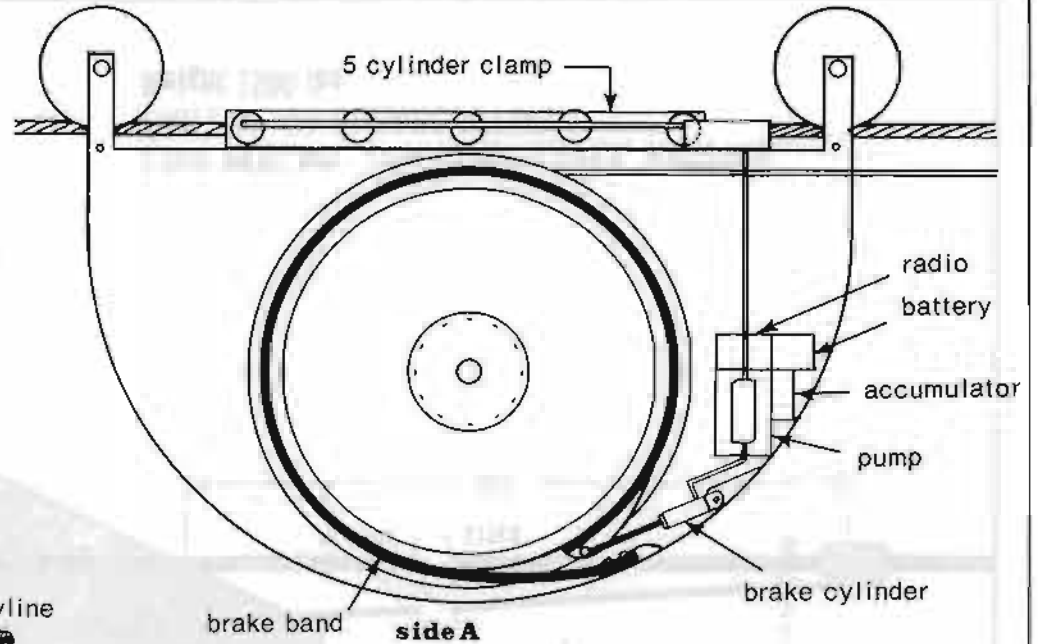
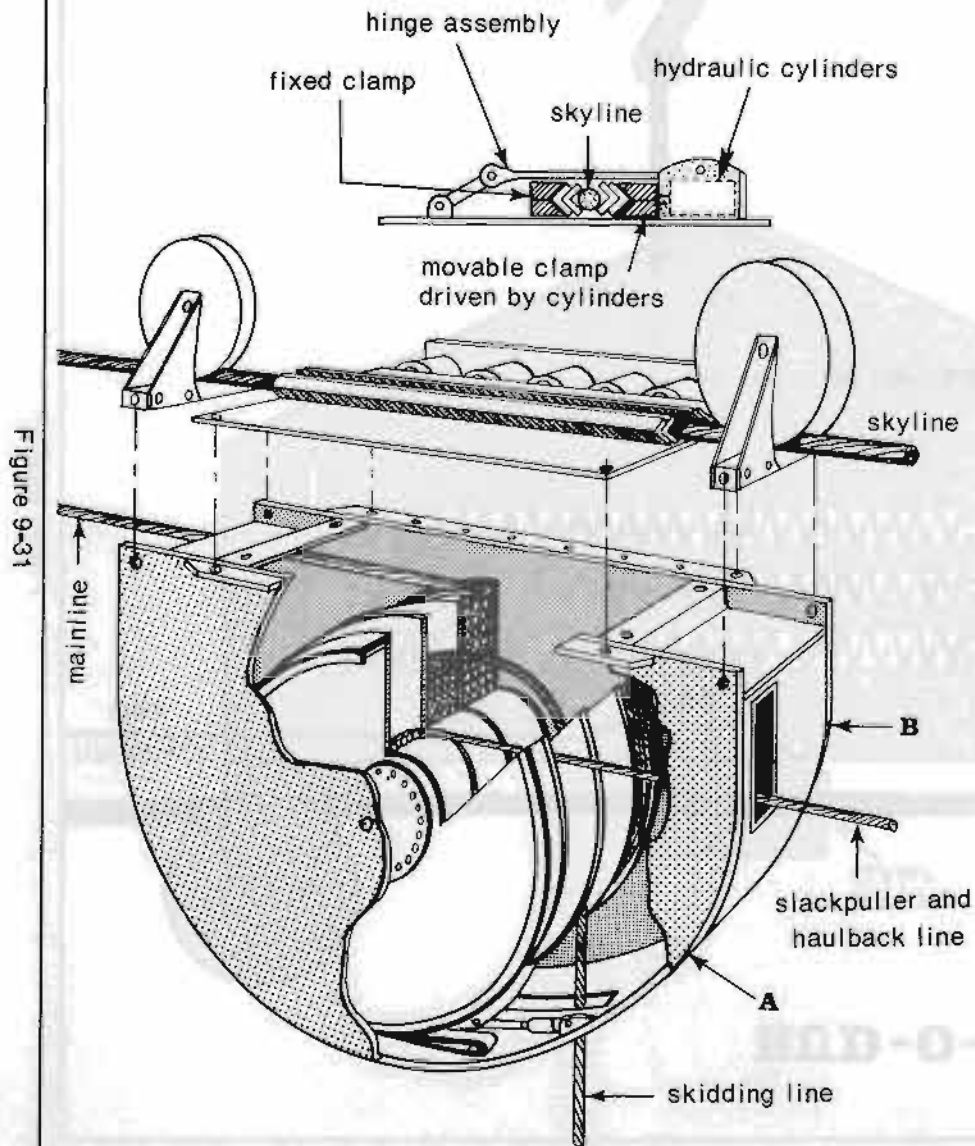
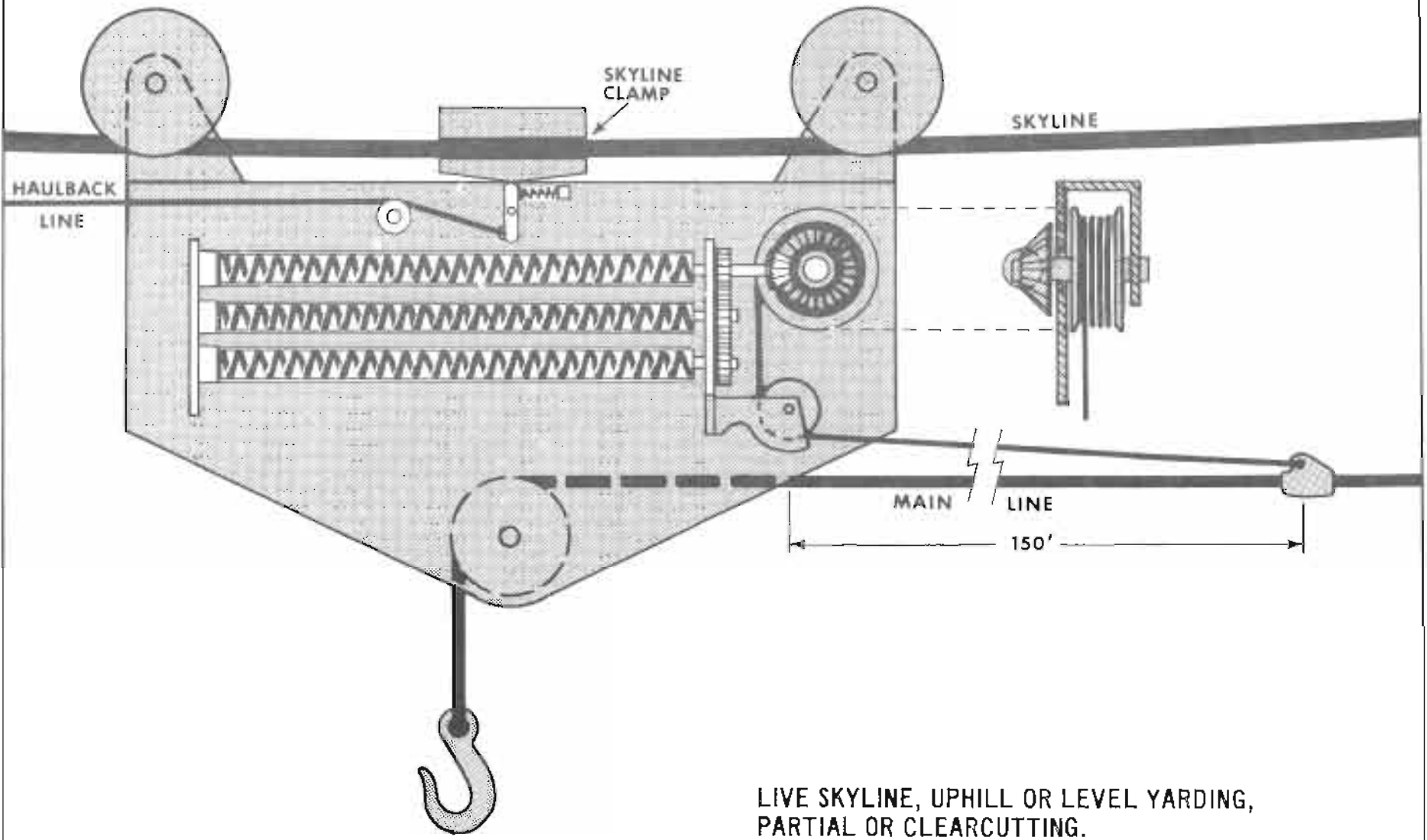

Figure 9-31

RUD-O-MATIC



LIVE SKYLINE, UPHILL OR LEVEL YARDING,
PARTIAL OR CLEARCUTTING.
Weight 1500 lbs.

Figure 9-32

SKYFLYER

Figure 9-33

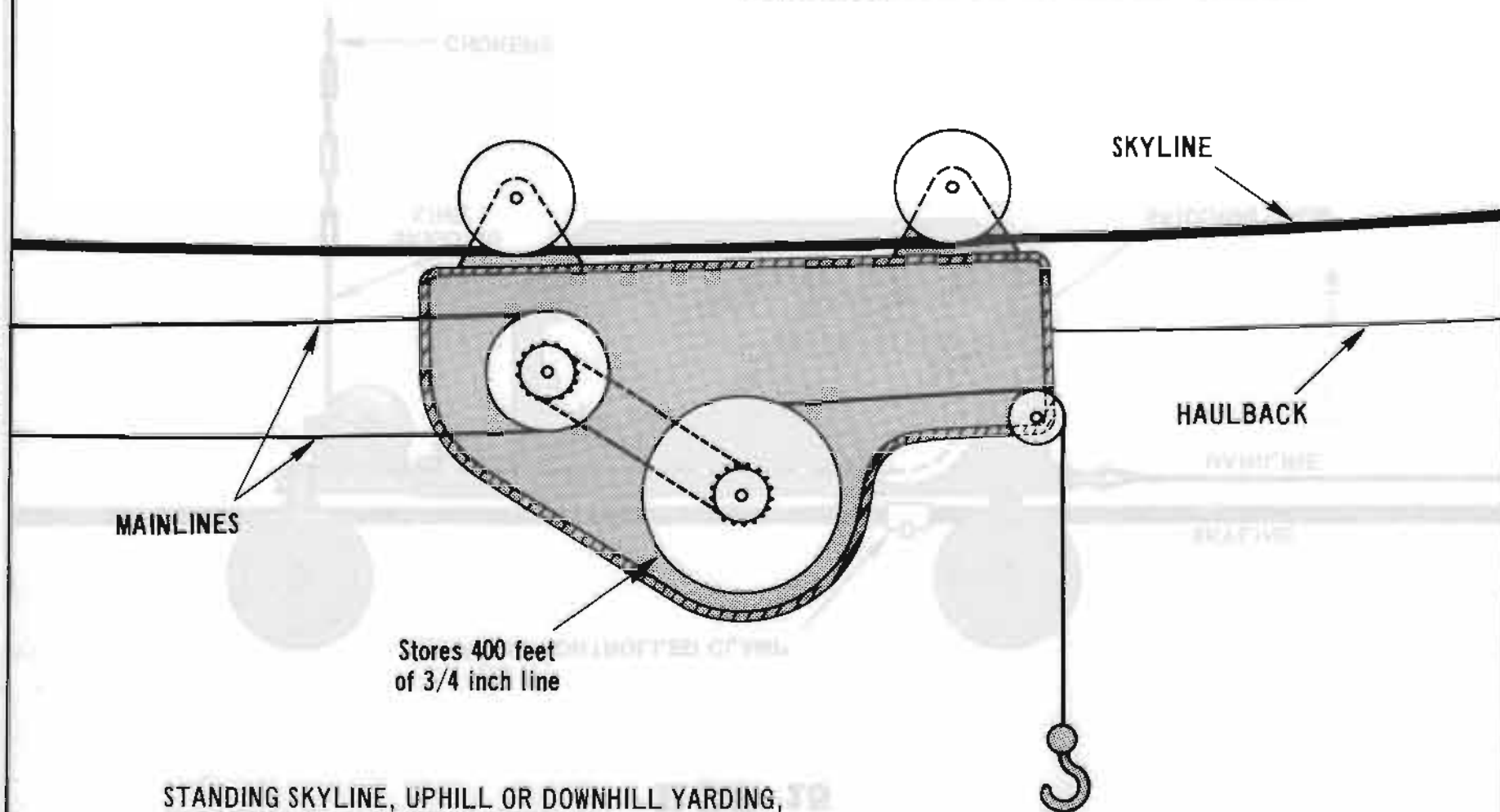

MAINLINES

SKYLINE

HAULBACK

Stores 400 feet
of 3/4 inch line

STANDING SKYLINE, UPHILL OR DOWNHILL YARDING,
CLEARCUT OR OVERSTORY REMOVAL.
Weight 7000 lbs.

RCC-15

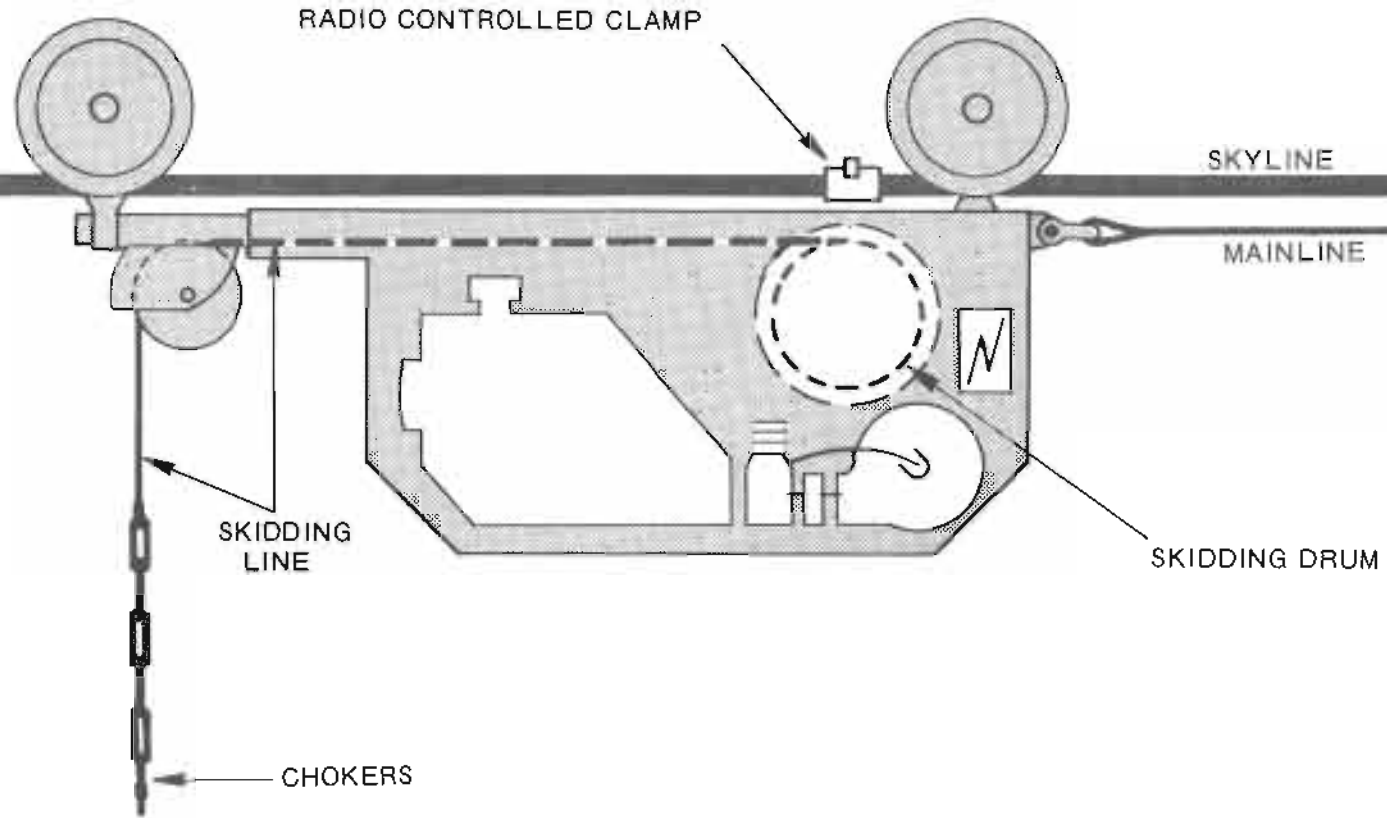

FOR SELECTIVE OR CLEARCUT LOGGING-
UPHILL OR DOWNHILL.

Figure 9-34

RCC - 13

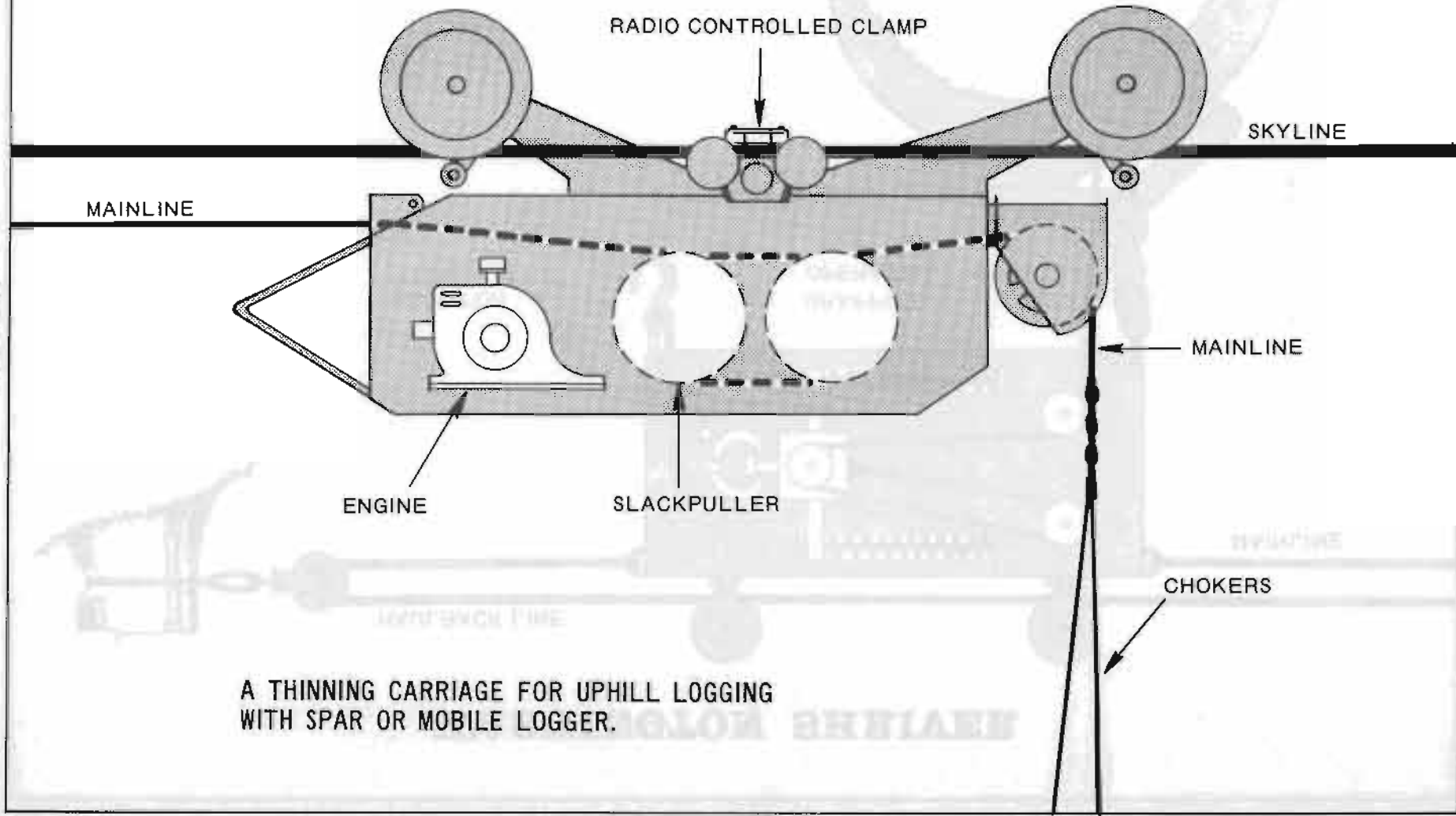

A THINNING CARRIAGE FOR UPHILL LOGGING WITH SPAR OR MOBILE LOGGER.

Figure 9-35

WASHINGTON SHRIVER

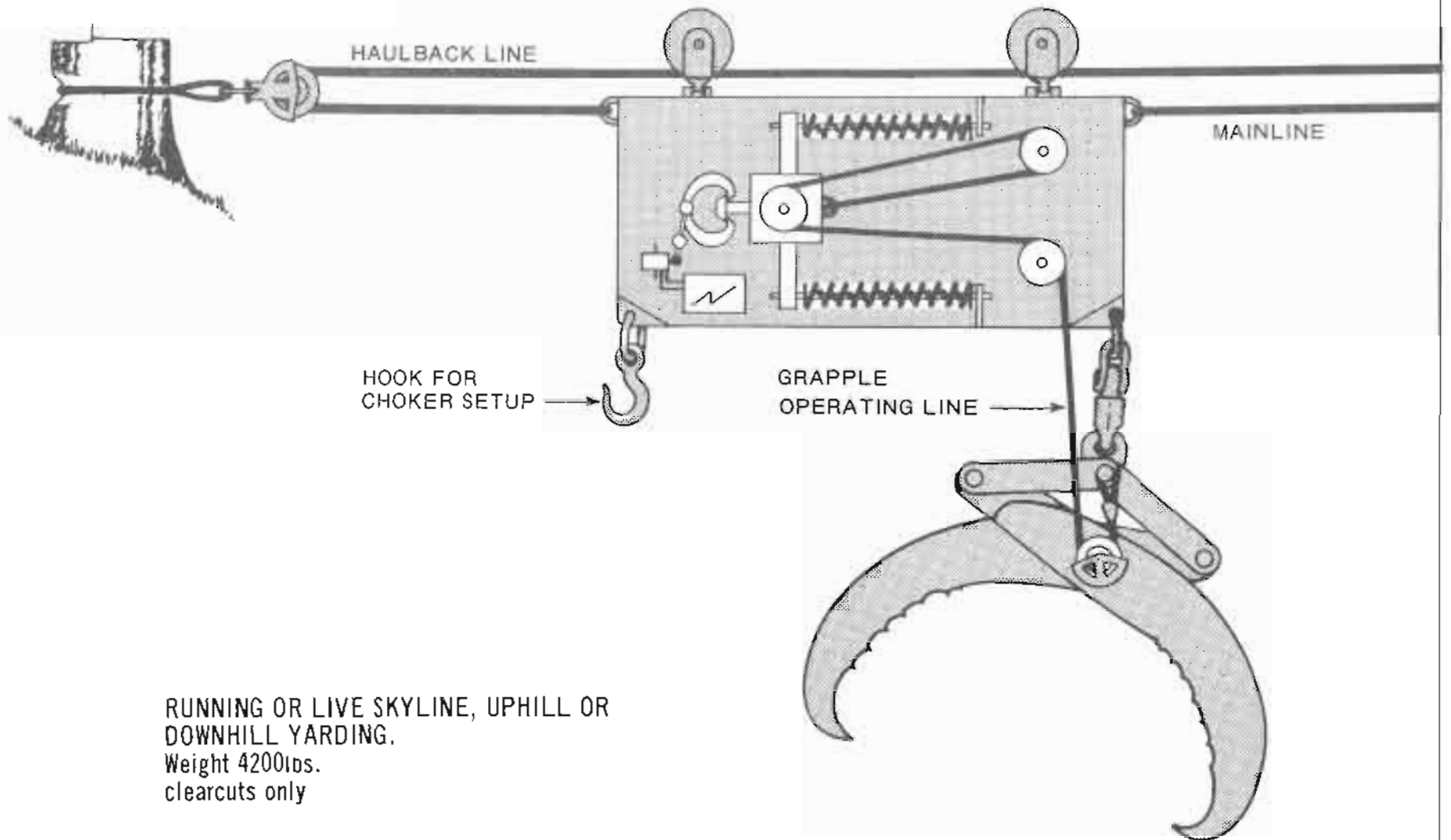
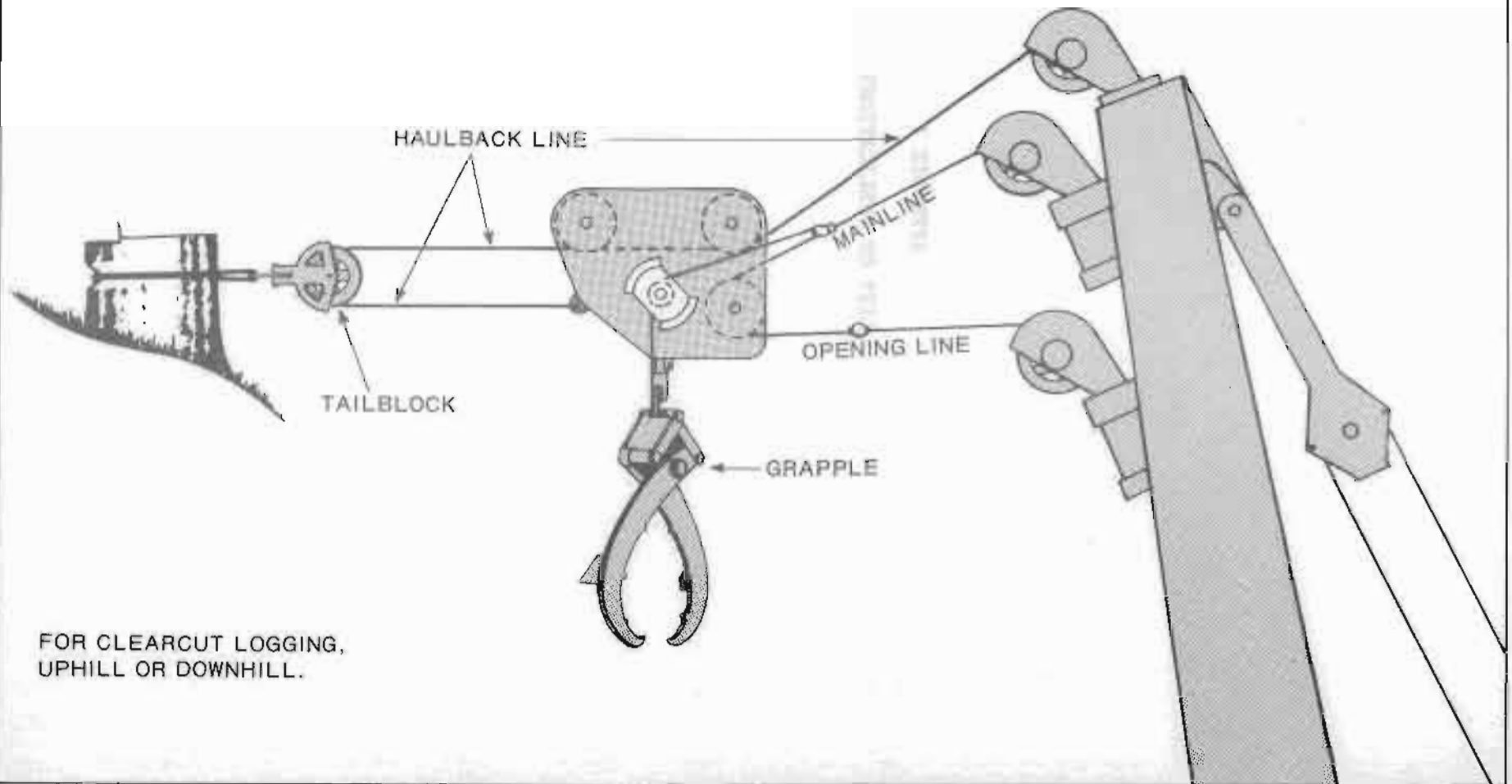

Figure 9-36

RUNNING SKYLINE GRAPPLE CARRIAGE

Figure 9-37



APPENDIX I
LIST OF PUBLICATIONS

FOREST SERVICE RESEARCH PAPERS

PNW-11	An Analysis of Production and Costs in Highlead Yarding	Tennas, Ruth & Berntsen	1955
PNW-23	Highlead Logging Costs and Related to Log Size and Other Variables	Adams	1965
PNW-24	Economic Comparison of ReLogging and Clean Logging in Mature Hemlock	Adams	1965
PNW-25	Economics and Design of a Radio-Controlled Skyline Yarding System	Binkley	1965
PNW-30	Logging Test of a Single-Hull Balloon	Lysons, Binkley Mann	1966
PNW-39	Skyline Tension and Deflection Handbook	Lysons & Mann	1967
PNW-39 (Supp.)	Supplement to "Skyline Tension and Deflection Handbook:	C. Campbell	1970
PNW-44	Logging Residue	Howard	1973
PNW-66	Planning Single-Span Skylines	Binkley & Lysons	1968
PNW-75	Mechanics of Running Skylines	Mann	1969
PNW-110	A Technique for the Solution of Skyline Catenary Equations	Carson & Mann	1970
PNW-115	Logging Residues on Douglas-fir Region Clearcuts--Weights and Volumes	Dell & Ward	1971
PNW-120	An Analysis of Running Skyline Load Patch	Carson & Mann	1971
PNW-138	A Method of Estimating Log Weights	Mann & Lysons	1972
PNW-157	A Computer Program for Determining the Load-Carrying Capability of the Running Skyline	Carson & Studier	1973
PNW	Understanding Interlock Yarders Part 1 - Description	Carson & Jorgensen	1973
	Glossary of Cable Logging Terms		1969
INT-59	Selecting Crawler Skidders by Comparing Relative Operating Costs	Schilling	1969
INT-60	A Technique for Comparing the Costs of Skidding Methods	Schilling	1969

INT-133	Optimum Economic Layout of Forest Harvesting Work Roads	Garter, Garner & Brown	1973
---------	---------------------------------------------------------	------------------------	------

NC-7	Designing Efficient Logging Systems for Northern Hardwoods, Using Equipment Production Capabilities & Costs	Gardner	1966
------	-------------------------------------------------------------------------------------------------------------	---------	------

FOREST SERVICE RESEARCH NOTES

PNW-24	Correction of Average Yarding Distance Factors for Circular Settings	Lysons & Mann	1965
--------	----------------------------------------------------------------------	---------------	------

PNW-42	Compatibility of Balloon Fabrics with Ammonia	Lysons	1966
--------	-----------------------------------------------	--------	------

PNW-55	Soil Surface Conditions Following Skyline Logging	Dyrness	1967
--------	---------------------------------------------------	---------	------

PNW-87	An Operational Test of a Natural-Shaped Logging Balloon	Binkley & Carson	1968
--------	---------------------------------------------------------	------------------	------

PNW-92	An Estimate of the Amount of Road in the Staggered-Setting System of Clearcutting	Silen & Gratkowski	1953
--------	-----------------------------------------------------------------------------------	--------------------	------

PNW-132	Digitalizing Topographic Data for Skyline Design Programs	Carson, Studier & Thomas	1970
---------	-----------------------------------------------------------	--------------------------	------

PNW-136	Preliminary Study of Dynamic Characteristics of Skyline Logging	Carson	1970
---------	-----------------------------------------------------------------	--------	------

PNW-152	Gross Static Lifting Capacity of Logging Balloons	Carson & Peters	1971
---------	---------------------------------------------------	-----------------	------

PNW-153	Running Skyline Design with a Desk-Top Computer/Plotter	Carson, Studier, & Lysons	1971
---------	---------------------------------------------------------	---------------------------	------

PNW-178	Average Yarding Distance on Irregular Shaped Timber Harvest Settings	Peters & Burke	1972
---------	----------------------------------------------------------------------	----------------	------

PNW-182	Soil Surface Conditions Following Balloon Logging	Dyrness	1972
---------	---------------------------------------------------	---------	------

PNW-186	Road and Landing Criteria for Mobile-Crane Yarding Systems	Burke	1972
---------	------------------------------------------------------------	-------	------

GENERAL REFERENCES

Report on an Administrative Study of Skyline Logging (Klamath National Forest)	Stillings & Gerson, USFS	1966
--------------------------------------------------------------------------------	--------------------------	------

Balloon Logging Systems Phase I - Analytical Study	Goodyear Aerospace Corporation	1964
----------------------------------------------------	--------------------------------	------

Balloon Logging Systems Phase II - Logistics Study	Goodyear Aerospace Corporation	1964
Tethered Balloon Handbook (Revised)	Myers, Goodyear Aerospace Corporation	1969
Guidelines for Stream Protection in Logging Operations	Lante, Oregon State Game Commission	1971
Industrial Waste Guide Logging Practices	Federal Water Pollution Control Administration	1970
Oregon State Safety Code, Chapter 16 Logging	Workmans Compensation Board	1969
Safety Standards for Logging Operations, State of Washington	Department of Labor and Industries	1972
Single-Span Skyline Timber Volume Survey	Pacific Northwest Region	1970
Skyline Logging - Symposium Proceedings	Oregon State University	1969
Skyline Logging Symposium: Proceedings	Washington University	1974
Cable Logging in the East: Symposium Proceeding	Virginia Polytechnic Institute	1973
Guides for Controlling Sediment From Secondary Logging Roads	Packer & Christensen U. S. Forest Service	
Guides for Protecting Water Quality	U. S. Forest Service	
Forest Land Uses and Stream Environment: Proceedings		1970
A Computerized System for the Engineering Design of Single-Span Standing Skylines Research Bulletin #848, Purdue University	Perkins, Suddurth & Stark	1969
Computer Analysis of Skyline Cable Systems	Swarthout U. S. Forest Service	1971
Forest Fuels, Prescribed Fire, and Air Quality	Hall, PNW	1972
"Woods Words"	McCulloch, Oregon Historical Society	1958
"Logging and Pulpwood Production" Ronald Press Company, New York	Pearce & Stengel	1972
"Logging-Principles & Practices" John Wiley & Sons, Inc.	Brown	1934

"Logging - Transportation" John Wiley & Sons, Inc.	Brown	1936
Loggers Handbooks	Pacific Logging Congress	
Oregon Logging Congress, Official Proceedings		
Western Conservation Journal	Seattle, Washington	
Forest Industries, Miller Freeman Pub.	San Francisco, California	
Timber Cutting Practices Miller Freeman Pub.	Steve Conway	1968
RIGGING REFERENCES		
Bethlehem Wire Rope	Bethlehem Steel Bethlehem, Pennsylvania	
Handling & Care of Wire Rope	" "	
Splicing Wire Rope	" "	
Wire Rope Handbook	Broderick & Bascom Rope Co. Seattle, Washington	
Riggers Handbook	" "	
Rigging Equipment, Catalog #221-A	Esco Corp., Portland, Oregon	
Wedge Type Ferrules, Catalog #284	" "	
Swage Fittings, Catalog #285	" "	
Skookum Blocks & Rigging, Catalog #SC72	The Skookum, Co. Portland, Oregon	
Tiger Brand Wire Rope Engineering Handbook	U.S. Steel Pittsburg, Pennsylvania	
Blocks & Rigging	Young Corporation Seattle, Washington	
Edwards Guide to Wire Rope Selection	E. H. Edwards Co. Seattle, Washington	
Edwards Wire Rope Data & Tables	" "	
Wire Rope Use & Abuse	" "	
Splicing and Fitting Edwards Wire Rope	" "	

SKYLINE ROAD PROFILE DATA SHEET

Date Name _____ of _____ Sheet _____ of _____

Range District _____ Date _____ Crew _____

Harvest Unit No. _____ Skyline Rd. No. _____

Asphalt or Gravel _____

Sta. No.	Dist. Ft.	Slope	Profile	Lateral	REMARKS: Type & Size of

APPENDIX II
FORMS

SKYLINE ROAD PROFILE DATA SHEET

Sale Name _____ Sheet _____ of _____
 Ranger District _____ Date _____ Crew _____
 Harvest Unit No. _____ Skyline Rd. No. _____
 Azimuth or Bearing _____

Sta. No.	Slope Dist Ft.	Profile Slope ±%	Lateral Slope ±%		REMARKS: Type & Size of Stand, Anchors, Spars, Rock Outcrops, Roads, Streams, etc.
			Lt.	Rt.	

WATER PROOF

SINGLE-SPAN SKYLINE WORKSHEET

Instructions: Refer to "Skyline Tension and Deflection Handbook and Supplement," Research paper PNW-39 1967 and PNW-39 (supp.) 1970.

Unit No. _____

Skyline Road No. _____

DETERMINE FROM SKYLINE PROFILE:

Horizontal span length (one station = 100 feet) _____ stations

Allowable loaded deflection _____ ft. at midspan X 100 _____ percent
 _____ horizontal span

Slope of span _____ ft. difference in vertical elevation X 100 _____ percent
 _____ horizontal span

GIVEN:

Cable: Diameter _____ inches Weight _____ pounds/foot

Breaking strength _____ kips (1 kip = 1,000 pounds)

Factor of safety _____ Safe working load _____ kips

Skyline carriage weight _____ kips Clamped _____ Nonclamping _____

DETERMINE REMAINING CABLE TENSION CAPABILITY:

Safe working load (given) _____ kips

Subtract tension due to cable weight (fig. 11 or table 2):

_____ kips/station/pound/feet x _____ stations x _____ pounds/feet - _____ kips

Remaining cable tension capability _____ kips

DETERMINE GROSS LOAD CAPABILITY:

Remaining tension capability _____ kips

Tension/kip of load* _____ kips/kip _____ kips

Subtract carriage weight _____ kips

Payload capability _____ kips

DETERMINE UNLOADED DEFLECTION:

Calculate load factor:

Remaining cable tension capability _____ kips

Tension due to cable weight _____ kips/sta/lb./ft. x _____ lb./ft. _____ kips

Allowable loaded deflection _____ percent

Subtract deflection change with load removed (figs. 14 to 29) _____ percent

Unloaded deflection _____ percent

DETERMINE UNLOADED TENSION USING UNLOADED DEFLECTION (fig. 11 or table 2):

_____ kips/sta./lb./ft. x _____ stations x _____ pounds/foot _____ kips

* Use figure 12 or table 3 when load is not clamped and is partially supported by a snubbing line. Use figure 13 or table 4 when the load is clamped to the skyline.

MULTISPAN SKYLINE WORKSHEET

Instructions: Refer to "Skyline Tension and Deflection Handbook and Supplement."
Research paper PNW-39 1967 and PNW-39 (supp.) 1970.

Unit No. _____

Skyline Road No. _____

DETERMINE FROM SKYLINE PROFILE:

Span location		Span No. _____
Horizontal span length (one station = 100 feet)		_____ stations
Loaded-midspan deflection	$\frac{\text{_____ ft. at midspan}}{\text{_____ horizontal span}} \times 100$	_____ percent
Slope of span	$\frac{\text{_____ ft. difference in vertical elevation}}{\text{_____ horizontal span}} \times 100$	_____ percent
Vertical distance from top of span to top of skyline		_____ feet

GIVEN:

Cable: Diameter _____ inches	Weight _____ pounds/foot	
Breaking strength _____ kips (1 kip = 1,000 pounds)		
Factor of safety _____	Safe working load _____ kips	
Skyline carriage weight _____ kips	Clamped _____ Nonclamping _____	

DETERMINE REMAINING CABLE TENSION CAPABILITY:

Safe working load (given)	_____ kips
Subtract tension between span and top of skyline:	
Vertical distance _____ ft. x _____ lbs./ft./1,000	- _____ kips
Safe working load at top of span	_____ kips
Subtract tension due to cable weight (fig. 11 or table 2):	
_____ kips/station/pound/feet x _____ stations x _____ pounds/foot	- _____ kips
Remaining cable tension capability	_____ kips

DETERMINE GROSS LOAD CAPABILITY:

Remaining tension capability _____ kips	_____ kips
Tension/kip of load* _____ kips/kip	
Subtract carriage weight	- _____ kips
Payload capability of span	_____ kips

* Use figure 12 or table 3 when load is not clamped and is partially supported by snubbing line. Use figure 13 or table 4 when load is clamped to skyline.

RUNNING SKYLINE WORKSHEET

(Yarder at Upper End)

Instructions: Refer to "Mechanics of Running Skylines," publication by Charles N. Mann, Research Paper PNW-75 1969.

Unit No. _____
 Skyline Road No. _____

DETERMINE FROM SKYLINE PROFILE:

Horizontal span length (one station = 100 feet) _____ stations
 Allowable loaded deflection _____ ft. at midspan X 100 _____ percent
 _____ horizontal span
 Slope of span _____ ft. difference in vertical elevation X 100 _____ percent
 _____ horizontal span

OBTAIN COEFFICIENTS FROM "SKYLINE TENSION AND DEFLECTION HANDBOOK"

Coefficient A (fig. 11 or table 2) _____ kip/sta./lb./ft.
 Coefficient B (fig. 12 or table 3) _____ kip/kip
 Coefficient C (fig. 13 or table 4) _____ kip/kip
 Coefficient D (2 x coeff. C _____ - coeff. B _____) _____ kip/kip

CARRIAGE WEIGHT (1 kip = 1,000 pounds) _____ kips

MAIN LINE ANALYSIS:

Specifications: Diameter _____ inches, Weight _____ pounds/foot
 Breaking strength _____ kips, Factor of safety _____
 Safe working load _____ kips (or maximum yarder line pull)

MAIN LINE CAPABILITY:

Safe working load _____ kips
 Subtract (coeff. A _____ x _____ stations x _____ pounds/foot) - _____ kips
 Remaining payload capability (R.P.C.) _____ kips
 Main line gross capability = $\frac{\text{R.P.C.} \times 2}{\text{Coeff. D}}$ _____ kips
 Subtract carriage weight - _____ kips
 Main line payload capability _____ kips
 (If main and haulback are the same size, this is system capability)

HAULBACK LINE ANALYSIS:

Specifications: Diameter _____ inches, Weight _____ pounds/foot
 Breaking strength _____ kips, Factor of safety _____
 Safe working load _____ kips (or maximum yarder line pull)

HAULBACK LINE CAPABILITY:

Safe working load _____ kips
 Subtract (coeff. A _____ x _____ stations x _____ pounds/foot) - _____ kips
 Remaining payload capability (R.P.C.) _____ kips
 Haulback line gross capability = $\frac{\text{R.P.C.} \times 2}{\text{Coeff. B}}$ _____ kips
 Subtract carriage weight - _____ kips
 Haulback payload capability _____ kips

SYSTEM PAYLOAD CAPABILITY*

* System payload is the lower of the main line or the haulback capability.

RUNNING SKYLINE WORKSHEET

(Yarder at Lower End)

Instructions: Refer to "Mechanics of Running Skylines," publication by Charles N. Mann, Research Paper PNW-75,1969

Unit No. _____

Skyline Road No. _____

DETERMINE FROM SKYLINE PROFILE:

Horizontal span length (one station = 100 feet)	_____ stations
Allowable loaded deflection: _____ ft. at midspan	_____ percent
_____ horizontal span	
Slope of span: _____ ft. difference in vertical elevation	_____ percent
_____ horizontal span	

OBTAIN COEFFICIENTS FROM "SKYLINE TENSION AND DEFLECTION HANDBOOK"

Coefficient A (fig. 11 or table 2)	kip/sta./lb./ft.	_____
Coefficient B (fig. 12 or table 3)		_____ kip/kip
Coefficient C (fig. 13 or table 4)		_____ kip/kip
Coefficient D (2 x coeff. B _____ - coeff. C _____)		_____ kip/kip
<u>CARRIAGE WEIGHT</u> (1 kip = 1,000 pounds)		_____ kips

HAULBACK LINE ANALYSIS:

Specifications: Diameter _____ inches, Weight _____ pounds/foot.
 Breaking strength _____ kips, Factor of safety _____
 Safe working load _____ kips (or maximum yarder line pull)

HAULBACK LINE CAPABILITY:

Safe working load	_____ kips
Subtract (coeff. A _____ x _____ stations x _____ pounds/foot)	- _____ kips
Remaining payload capability (R.P.C.)	_____ kips
Haulback gross capability = $\frac{\text{R.P.C.} \quad \text{_____ kips} \times 2}{\text{Coeff. C} \quad \text{_____}}$	_____ kips
Subtract carriage weight	- _____ kips
Haulback line payload capability (If main and haulback are the same size, this is system capability)	_____ kips

MAIN LINE ANALYSIS:

Specifications: Diameter _____ inches, Weight _____ pounds/foot.
 Breaking strength _____ kips, Factor of safety _____
 Safe working load _____ kips (or maximum yarder line pull)

MAIN LINE CAPABILITY:

Safe working load	_____ kips
Subtract (coeff. A _____ x _____ stations x _____ pounds/foot)	- _____ kips
Remaining payload capability (R.P.C.)	_____ kips
Main line gross capability = $\frac{\text{R.P.C.} \quad \text{_____ kips} \times 2}{\text{Coeff. D} \quad \text{_____}}$	_____ kips
Subtract carriage weight	- _____ kips
Main line payload capability	_____ kips

SYSTEM PAYLOAD CAPABILITY*

_____ kips

* System payload is the lower of the main line or the haulback capability.

Form 450 (Rev. 10-1-70) 450

USDA, FOREST SERVICE

SINGLE - SPAN SKYLINE SUMMARY SHEET

Instructions: Refer to "Supplement to Skyline Tension and Deflection" Handbook
Research Paper PMW-39 (supp.) 1970 by Charles D. Campbell.

District _____

State _____

Initial & Date _____

Height of Tower _____ feet

Skyline Diameter _____ inches

Carriage: weight _____ Kips*
clamping _____
non-clamping _____

(1)	(2)	(3)	(4)	(5)	(6)	(7)	(8)	(9)	(10)	(11)	(12)	(13)	(14)	(15)	(16)
Skyline Unit & Road No.	Uphill or Downhill Yarding	Fan-shaped or Rectangular Setting	Span Length (ft.) (Horizontal)	External Yarding Distance (ft.) (slope dist.)	Tail Spar Height (ft.)	Type of Skyline Anchor (Deadman) (stump, etc.)	Elevation Difference of Span (ft.) (vertical)	Chord Slope of Span (%)	Clearance Minimum on Span (ft.)	Deflection at Midspan (ft.)	Midspan Deflection (%)	Gross Payload From Graph (Kips)	Net Calculated Payload (Kips)	Payload Conversion (#/bd-ft)	

* 1 Kip = 1000 pounds.

Number of road profiles calculated _____ ÷ number of skyline setups needed to yard the area _____ X 100 = _____ % of skyline roads sampled.

State whether the above skyline road profiles were randomly selected _____, or are they the most difficult road profiles on the area to be yarded _____.

Have the above skyline road profiles been field checked? _____



USDA, FOREST SERVICE

SINGLE - SPAN SKYLINE SUMMARY SHEET

Instructions: Refer to "Supplement to Skyline Tension and Deflection" Handbook Research Paper PNM-39 (supp.) 1970 by Charles G. Campbell

District _____

State _____

Initial & Date _____

Height of Tower _____ feet

Skyline Diameter _____ inches

Carriage: weight _____ Rips*
 clamping _____
 non-clamping _____

(1)	(2)	(3)	(4)	(5)	(6)	(7)	(8)	(9)	(10)	(11)	(12)	(13)	(14)	(15)	(16)
Skyline Unit & Road No.	Uphill or Downhill Yarding	Fan-shaped or Rectangular Setting	Span Length (ft.) (horizontal)	External Yarding Distance (ft.) (slope dist.)	Tail Spar Height (ft.)	Type of Skyline Anchor (deadman) (stump, etc)	Elevation Difference of Span (ft.) (vertical)	Chord Slope of Span (%)	Clearance Minimum on Span (ft.)	Deflection at Midspan (ft.)	Midspan Deflection (ft.)	Gross Payload From Graph (Kips)	Net Calculated Payload (Kips)	Payload Conversion (___#/bd.ft)	

* 1 Kip = 1000 pounds

Number of road profiles calculated _____ * number of skyline setups needed to yard the area _____ X 100 = _____ % of skyline roads sampled.

State whether the above skyline road profiles were randomly selected _____, or are they the most difficult road profiles on the area to be yarded _____.

Have the above skyline road profiles been field checked? _____

