

This file was created by scanning the printed publication.  
Errors identified by the software have been corrected;  
however, some errors may remain.



United States  
Department of  
Agriculture

Forest Service

Rocky Mountain  
Forest and Range  
Experiment Station

Mark Collins  
Colorado 80526

General Technical  
Report RM-120



# RIPARIAN ECOSYSTEMS AND THEIR MANAGEMENT: Reconciling Conflicting uses

## First North American Riparian Conference

April 16-18, 1985  
Tucson, Arizona

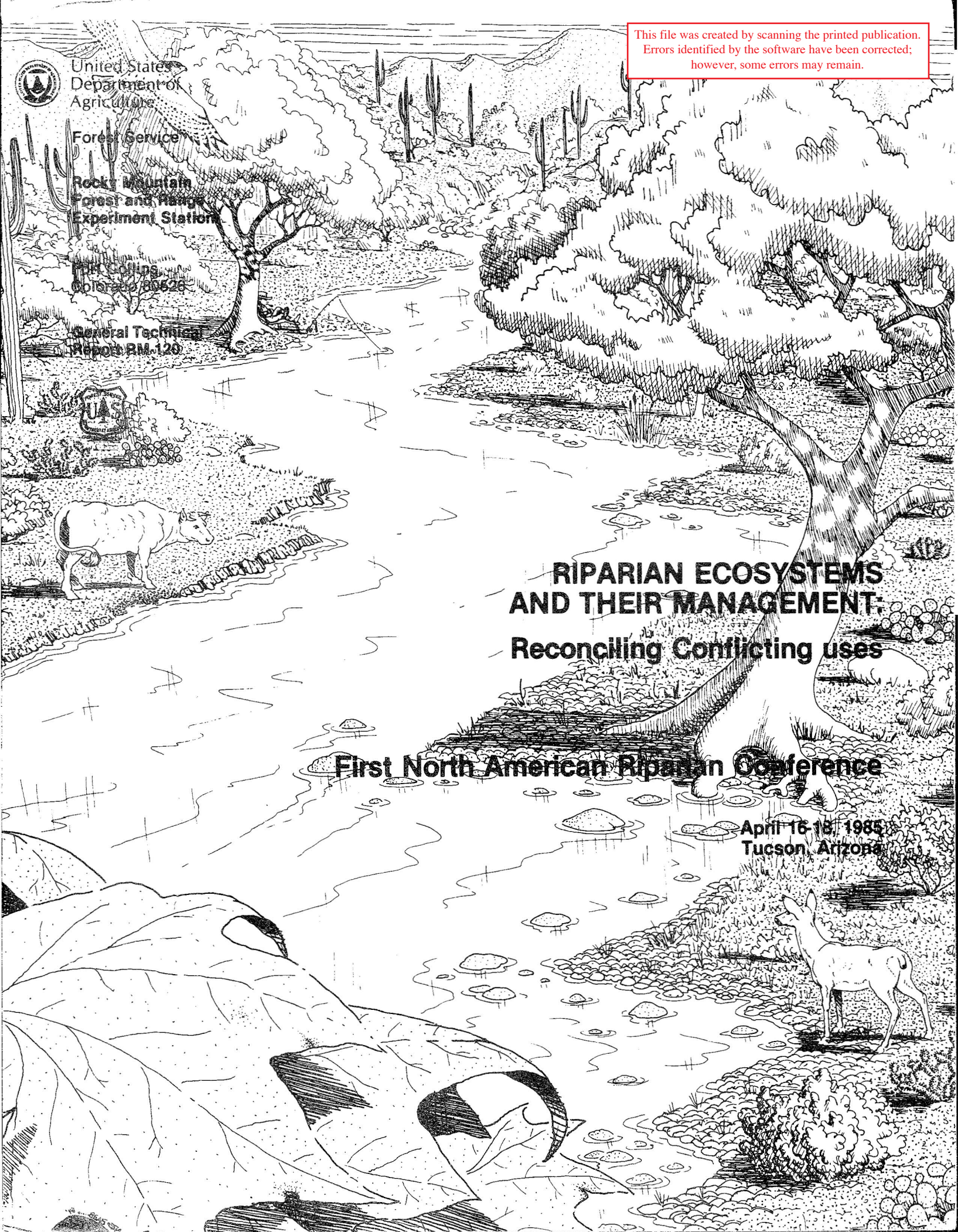

## PREFACE TO THE SECOND PRINTING OF RM-120

The Proceedings of the First North American Riparian Conference were issued by the Rocky Mountain Forest and Range Experiment Station, Fort Collins, Colorado, during the summer of 1985. The conference, held in Tucson on April 16 to 18, 1985, was attended by more than 400 persons from throughout North America at a time when budget problems were devastating for those from the United States as well as Mexico. The popularity of the conference was confirmed by exhaustion of the supply of 3,000 copies of the proceedings by January 1986.

This second printing of 1,000 copies is being issued by the Riparian/Wetlands Committee of the School of Renewable Natural Resources, University of Arizona, in cooperation with the North American Riparian Council. Proceeds from this printing will be used to further the perpetuation of riparian systems through research, conservation education, and their wise use through proper management.

Agencies which cosponsored the April 1985 conference are listed under "Acknowledgements." Agencies listed on the title page furnished funding for the first printing. In addition, the National Park Service, Tennessee Valley Authority, and University of Arizona Centennial Committee provided generous aid for other conference and associated publication costs. The conference was dedicated to Dr. Richard E. Warner, a California riparian ecologist and organizer of the large California riparian conference in 1981, who died at the height of his career in 1984.

The success of this undertaking is due to outstanding assistance from session chairs, listed elsewhere, as well as to the personal interest and help from a number of additional people who assisted with the conference. Those whose assistance during the course of the conference deserves special mention include Frank Gregg, Director, School of Renewable Natural Resources; Raymond H. Thompson, Chairman, University of Arizona Centennial Committee; Robert H. Hamre, Chief, Publications Section, Rocky Mountain Forest and Range Experiment Station; and members of the National Park Service Cooperative National Park Resources Studies Unit/University of Arizona--Douglas K. Duncan, Lupe P. Hendrickson, and Elaine Johnson-Duncan.

This second printing will still not provide a copy of these proceedings for everyone who wishes one. Special care has been taken, however, to provide copies to strategically located libraries throughout North America as well as to various offices of federal and state resource management agencies.

Address further enquiries to R. Roy Johnson, Chairman, North American Riparian Council, 125 Biological Sciences (East), University of Arizona, Tucson, AZ 85721.

## Acknowledgments

Any meeting of this size and scope owes its success to a large number of individuals and organizations. First, we thank the sponsoring organizations (listed on the Title Page) whose financial support and encouragement helped make the conference a reality. The 360 registrants and approximately 100 additional persons who attended selected sessions demonstrated a sizable constituency for enlightened riparian management.

We are especially grateful to those who presided over the many concurrent sessions, or who donated their time on the technical and publications committees. Members of the University of Arizona Student Chapter of the Wildlife Society provided invaluable support both during and before the conference, as did personnel of the National Park Service Cooperative Resources Studies Unit at the University.

Two outstanding individuals, both with advanced degrees in science and law, contributed to the success of the conference--Bruce Babbitt, Governor of Arizona, and Dr. Jon Kusler, Chairman, The Association of State Wetland Managers, Inc. Governor Babbitt took time from a busy schedule to present a conference address demonstrating his understanding of riparian ecosystems both as a scientist and as a politician. Dr. Kusler spent many hours meeting with study groups, contributing both his scientific and legal expertise to aid in the formulation of model draft riparian legislation (see Proceedings Appendix, p. 515) and to address other riparian concerns.

Finally, we thank the speakers at the conference for preparing their papers in camera-ready form to expedite publications of the proceedings. Each contributor is responsible for the accuracy and style of his or her paper. Statements by contributors do not necessarily reflect the policy of the USDA Forest Service or other conference sponsors.

The Riparian/Wetland Committee  
School of Renewable Natural Resources  
The University of Arizona

### SESSION CHAIRS

Ward Brady, Arizona State University  
Steven W. Carothers, SWC Associates  
Virginia Carter, U.S. Geological Survey  
Terry C. Daniel, University of Arizona  
Exequiel Ezcurra, Instituto de Ecologia  
Peter F. Ffolliott, University of Arizona  
Lloyd W. Gay, University of Arizona  
Frank Gregg, University of Arizona  
Charles F. Hutchinson, University of Arizona  
Helen M. Ingram, University of Arizona  
David A. King, University of Arizona

Paul R. Krausman, University of Arizona  
Charles H. Lowe, University of Arizona  
David A. Mouat, Stanford University  
Gary Nabhan, University of Arizona  
David R. Patton, USDA Forest Service  
Dick W. Reeves, University of Arizona  
William W. Shaw, University of Arizona  
Robert C. Szaro, USDA Forest Service  
A. Heaton Underhill, University of Arizona  
L. G. Wilson, University of Arizona  
Ervin H. Zube, University of Arizona

### PARTICIPATING AGENCIES AND ORGANIZATIONS

American Fisheries Society  
American Forestry Association  
American Water Resources Association  
Arizona Game and Fish Department  
Association of State Wetland Managers  
Environmental Research Laboratory  
(Univ. of Arizona)  
Instituto de Ecologia  
Instituto Nacional de  
Investigaciones Forestales  
International Association of Fish  
and Wildlife Agencies  
International Union for the Conservation  
of Nature and Natural Resources  
IX World Forestry Congress (Mexico)

PRONATURA (Mexico)  
Sport Fishing Institute  
Tennessee Valley Authority  
US Corps of Engineers  
US Environmental Protection Agency  
US Geological Survey  
US Man and The Biosphere Program  
USDA Soil Conservation Service  
USDA Forest Service  
USDI Bureau of Land Management  
USDI Bureau of Reclamation  
USDI Fish and Wildlife Service  
USDI National Park Service  
Wildlife Management Institute  
The Wildlife Society

**RIPARIAN ECOSYSTEMS  
AND THEIR MANAGEMENT:  
Reconciling Conflicting uses**

**First North American Riparian Conference**

**April 16-18, 1985  
Tucson, Arizona**

**Technical Coordinators:**

**R. Roy Johnson  
Charles D. Ziebell  
David R. Patton  
Peter F. Ffolliott  
R. H. Hamre**

**Sponsored by:**

**USDA Forest Service  
USDA Soil Conservation Service  
USDI Bureau of Land Management  
USDI Bureau of Reclamation  
USDI Fish and Wildlife Service  
University of Arizona**

**Rocky Mountain Forest and Range Experiment Station  
Forest Service  
U.S. Department of Agriculture**

# Table of Contents

Foreword: Bruce Babbitt, Governor of Arizona . . . . .	viii
THE RIPARIAN CONFERENCE: Plenary Papers	
A Summary of Socio-Economic Presentations at the First North American Conference on Riparian Ecosystems and Their Management. . . . .	1
Philip A. Meyer	
A Summary of Biological and Physical Science Presentations at the First North American Conference on Riparian Ecosystems and Their Management . . . . .	3
David W. Crumpacker	
A Call for Action: Protection of Riparian Habitat in the Arid and Semi-Arid West. . . . .	6
Jon Kusler	
Riparian Ecosystems in Mexico: Current Status and Future Direction . . . . .	9
Miguel Caballero Deloya	
Thinking Laterally: Strategies for Strengthening Institutional Capacity for Integrated Management of Riparian Resources. . . . .	13
C. David Loeks	
American Fisheries Society Position Statement: Strategies for Riparian Area Management. . . . .	21
Gordon N. Haugen	
Riparian Zone Protection by TVA: An Overview of Policies and Programs. . . . .	23
Roosevelt T. Allen and Ronald J. Field	
Position Paper: Activities and Views of the U.S. Fish and Wildlife Service on Riparian Ecosystems. . . . .	27
Michael J. Spear	
PHYSICAL CHARACTERISTICS OF RIPARIAN ECOSYSTEMS	
The Effects of Large Storm Events on Basin-Range Riparian Stream Habitats. . . . .	30
William S. Platts, Karl A. Gebhardt, and William L. Jackson	
Erosional Downcutting in Lower Order Riparian Ecosystems: Have Historical Changes Been Caused by Removal of Beaver?. . . . .	35
Michael Parker, Fred Wood Jr., Bruce H. Smith, and Robert G. Elder	
The Development of Southwestern Riparian Gallery Forests. . . . .	39
Ward Brady, David R. Patton, and Jay Paxson	
Interdependence of Groundwater, Riparian Vegetation, and Streambank Stability: A Case Study. . . . .	44
David F. Groeneveld and Thomas E. Griepentrog	
Physical Characteristics and Pedogenesis of Soils in Riparian Habitats Along the Upper Gila River Basin. . . . .	49
John H. Brock	
Interactions Between Streamside Vegetation and Stream Dynamics. . . . .	54
Burchard Heede	
Emergency Measures for Streambank Stabilization: An Evaluation. . . . .	59
Ronald F. Schultze and Glenn I. Wilcox	

Renovation of a Plains State Stream -- Physical Problem Solving. . . . .	62
Thomas J. Taylor and John S. Barclay	
A Comparison of Riparian Area Ground Data with Large Scale Airphoto Interpretation. . . . .	67
Paul Cuplin, William S. Platts, Osborne Casey, and Roy Masinton	
Riparian Area Inventory and Monitoring Using Large Scale Infrared Photography. . . . .	69
Paul Cuplin	
ECOLOGY OF RIPARIAN ECOSYSTEMS	
Glen Canyon Environmental Studies: An Interagency Effort to Resolve Resource Management Conflicts. . . . .	72
John K. Thomas	
Glen Canyon Dam, Fluctuating Water Levels, and Riparian Breeding Birds: The Need for Management Compromise on the Colorado River in Grand Canyon . . . . .	76
Bryan T. Brown and R. Roy Johnson	
The Effects of Prolonged Flooding on the Riparian Plant Community in Grand Canyon. . . . .	81
Lawrence E. Stevens and Gwendolyn L. Waring	
A Method for Evaluating Streamflow Discharge -- Plant Species Occurrence Patterns on Headwater Streams. . . . .	87
Richard R. Harris, Roland J. Risser, and Carl A. Fox	
A Stream Classification System. . . . .	91
David L. Rosgen	
The Importance of Riparian Habitats for the Conservation of Endangered Mammals in Mexico. . . . .	96
Gerardo Ceballos-G.	
The Linear Interval Method for Determining Habitat Selection of Riparian Wildlife Species. . . . .	101
Kerry M. Christensen	
Significance of Riparian Vegetation to Breeding Birds Across an Altitudinal Cline. . . . .	105
Fritz L. Knopf	
On the Development of Riparian Ecology. . . . .	112
R. Roy Johnson and Charles W. Lowe	
Influence of Agriculture on Waterbird, Wader, and Shorebird Use Along the Lower Colorado River. . . . .	117
Robert D. Ohmart, Bertin W. Anderson, and William C. Hunter	
Managing Riparian Vegetation and Wildlife Along the Colorado River: Synthesis of Data, Predictive Models, and Management. . . . .	123
Bertin W. Anderson and Robert D. Ohmart	
Summer Avian Community Composition of Tamarix Habitats in Three Southwestern Desert Riparian Systems. . . . .	128
William C. Hunter, Bertin W. Anderson, and Robert D. Ohmart	
Revegetating Riparian Trees in Southwestern Floodplains. . . . .	135
Edwin A. Swenson and Charles L. Mullins	
Limits on Regeneration Processes in Southeastern Riverine Wetlands. . . . .	139
R. R. Sharitz and L. C. Lee	
Xeroriparian Systems Used by Desert Mule Deer in Texas and Arizona. . . . .	144
Paul R. Krausman, Kurt R. Rautenstrauch, and Bruce D. Leopold	

Gradient Analysis of a Sonoran Desert Wash. . . . .	150
Peter L. Warren and L. Susan Anderson	
Avian Use of Xeroriparian Ecosystems in the North American Warm Deserts. . . . .	156
R. Roy Johnson and Lois T. Haight	

HYDROLOGY OF RIPARIAN SYSTEMS

Comparison of Three Micrometeorological Methods to Calculate Evapotranspiration in Owens Valley, California. . . . .	161
Lowell F. W. Duell Jr. and Diane M. Nork	
A Field Assessment of Above- and Below-Ground Factors Affecting Phreatophyte Transpiration in the Owens Valley, California. . . . .	166
D. P. Groeneveld, D. L. Grate, P. J. Hubbard, D. S. Munk, P. J. Novak, B. Tillemans, D. C. Warren, and I. Yamashita	
Evapotranspiration From Saltcedar Along the Lower Colorado River. . . . .	171
Lloyd W. Gay	
Classification of Nitrate Uptake by Riparian Forests and Wetlands in an Undisturbed Headwaters Watershed. . . . .	175
Jonathan Rhodes, C. M. Skau, Daniel Greenlee, and David L. Brown	
Aquatic Organic Carbon and Nutrient Fluxes, Water Quality, and Aquatic Productivity in the Atchafalaya Basin, Louisiana. . . . .	180
Victor W. Lambou	
Management of Streamside Zones on Municipal Watersheds. . . . .	187
Edward S. Corbett and James A. Lynch	
Water Resource Conservation by Reducing Phreatophyte Transpiration. . . . .	191
Robert W. Ritzi, Herman Bouwer, and Soroosh Sorooshian	
Methods for Determining Effects of Controlled Dewatering of Shallow Aquifers on Desert Phreatophytes in Owens Valley, California. . . . .	197
Peter D. Dileanis, Farrel A. Pranson, and Stephen K. Sorenson	
Multiple Regression Analysis for Evaluating Non-Point Source Contributions to Water Quality in the Green River, Wyoming. . . . .	201
Timothy E. Fannin, Michael Parker, and Timothy J. Maret	
Increasing Summer Flow in Small Streams Through Management of Riparian Areas and Adjacent Vegetation: A Synthesis. . . . .	206
D. Frederic Stabler	
The Effects of Streamflow Modification on the Development of a Riparian Ecosystem. . . . .	211
Robert C. Szaro and Leonard F. DeBano	

RIPARIAN RESOURCES:

RECREATION

Focused Recreation Use in Riparian Ecosystems: A Taxonomy of User Types. . . . .	216
Jean C. Behrens-Tepper, Joseph T. O'Leary, and Douglas C. Andersen	
The Economic Value of Sportfishing at Lees Ferry, Arizona. . . . .	219
Merton T. Richards and D. Brent Wood	
A Wilderness Riparian Environment: Visitor Satisfaction, Perceptions, Reality, and Management. . . . .	223
Sharon L. Hoover, David A. King, and William J. Matter	

Human Behavior and Recreation Habitats: Conceptual Issues. . . . .	227
Donald R. Field, Martha E. Lee, and Kristen Martinson	
AGRICULTURE	
Riparian Vegetation and Indigenous Southwestern Agriculture: Control of Erosion, Pests, and Microclimate. . . . .	232
Gary Paul Nabhan	
REM: A Model for Riparian Ecosystem Management in Agricultural Watersheds. . . . .	237
Richard Lawrence and Adel Shirmohammadi	
Riparian Vegetation Reduces Stream Bank and Row Crop Flood Damages. . . . .	241
Donald Roseboom and Kenneth Russell	
The Pecan Orchard as a Riparian Ecosystem. . . . .	245
Kenneth J. Kingsley	
Relationships Between the Expansion of Agriculture and the Reduction of Natural Riparian Habitat in the Missouri River Floodplain of Northeast Montana, 1938 - 1982. . . . .	250
Alexander R. Hoar and Michael J. Erwin	
WILDLIFE	
Management Goals and Habitat Structure. . . . .	257
Henry L. Short	
Streamside Management Zones and Wildlife in the Southern Coastal Plain. . . . .	263
James G. Dickson and Jimmy C. Huntley	
Tennessee Valley Authority's Management of Riparian Zones to Benefit Wildlife. . . . .	265
Ronald J. Field and Roosevelt T. Allen	
Responses of Small Mammals to Forest Riparian Perturbations. . . . .	269
Stephen P. Cross	
LIVESTOCK USE	
Channel Response of an Ephemeral Stream in Wyoming to Selected Grazing Treatments. . . . .	276
Ronald E. Siekert, Q. D. Skinner, M. A. Smith, J. L. Dodd, and J. D. Rodgers	
Time of Grazing and Cattle-Induced Damage to Streambanks. . . . .	279
Clayton B. Marlow and Thomas M. Pogacnik	
Livestock Management in the Riparian Ecosystem. . . . .	285
Larry D. Bryant	
Grazing Management Influences on Two Brook Trout Streams in Wyoming. . . . .	290
Wayne A. Hubert, Robert P. Lanka, Thomas A. Wesche, and Fred Stabler	
Livestock Grazing Effects on Southwestern Streams: A Complex Research Problem. . . . .	295
John N. Rinne	
The Use of Cattle as a Management Tool for Wildlife in Shrub-Willow Riparian Systems . . . . .	300
Henry O. Krueger and Stanley H. Anderson	



Above-Ground Biomass Quantities and Livestock Production at Big Sacaton Riparian Areas in Southeastern Arizona. . . . .	305
Jerry R. Cox and Howard L. Morton	

FISHERIES

Trout Habitat, Abundance, and Fishing Opportunities in Fenced vs Unfenced Riparian Habitat Along Sheep Creek, Colorado. . . . .	310
Robert J. Stuber	

The Value of Riparian Zones for Protecting Aquatic Systems: General Concerns and Recent Studies in Maine. . . . .	315
John R. Moring, Greg C. Garman, and Dennis M. Mullen	

The Fish Habitat Management Unit Concept for Streams on National Forests in Alaska. . . . .	320
Dave R. Gibbons	

Importance and Evaluation of Instream and Riparian Cover in Smaller Trout Streams. . . . .	325
Thomas A. Wesche, Chris M. Goertler, and Carrie B. Frye	

Changes 30 Years After Logging in Large Woody Debris, and Its Use by Salmonids. . . . .	329
Mason D. Bryant	

A Method for Assessing the Value of Stream Corridors to Fish and Wildlife Resources. . . . .	335
John C. Garcia	

AMPHIBIANS AND REPTILES

Amphibians and Reptiles in Southwest Riparian Ecosystems. . . . .	339
Charles H. Lowe	

Microhabitats of Lizards in a Southwestern Riparian Community. . . . .	342
K. Bruce Jones and Patricia Conley Glinski	

Herpetofauna in Riparian Habitats Along the Colorado River in Grand Canyon. . . . .	347
Peter L. Warren and Cecil R. Schwalbe	

Herpetofaunal Use of Four Habitats of the Middle Gila River Drainage, Arizona. . . . .	355
Martin D. Jakle and Thomas A. Gatz	

Impact of Grazing on a Riparian Garter Snake. . . . .	359
Robert C. Szaro, Scott C. Belfit, J. Kevin Aitkin, and John N. Rinne	

MULTIPLE-USE PLANNING AND MANAGEMENT

Riparian Management of Coastal Pacific Ecosystems. . . . .	364
Mark T. Anderson	

Water and People: Common Denominators in Riparian Zones. . . . .	369
John C. Buckhouse	

Integration of Riparian Systems Management Strategies Within the Context of Multiple Use Land Management Programs in Southwestern Wyoming. . . . .	371
Donald H. Sweep, J. M. Zilincar, Bruce H. Smith, and Rodd V. Hardy	

Reclamation of Riparian Zones and Water Law: First in Time -- First in Right. . . . .	374
Quentin D. Skinner, Michael A. Smith, Jerrold L. Dodd, and J. Daniel Rodgers	

Impacts of Oil and Gas Development on Riparian Zones in the Overthrust Belt: The Role of Industrial Siting. . . . .	379
Robert G. Elder, and Richard C. Moore	
Evaluating Effects of Management on Riparian Ecosystems. . . . .	384
Martin N. Fogel and Peter F. Ffolliott	
The Boulder Creek Corridor Projects: Riparian Ecosystem Management in an Urban Setting. . . . .	389
David W. Crumpacker	
Using Visitor Perceptions in River Use Planning, 1972 -- 1984. . . . .	393
Kenneth C. Chilman, David Foster, and Alan Everson	
The Site Signature Method of Land Suitability Planning in River Corridors. . . . .	398
David P. Hill	
Strategic Riparian Resource Management in a Metropolitan Setting: The Minnesota Valley Experience. . . . .	403
Tim Kelly	
Research Issues in Riparian Landscape Planning. . . . .	408
Kerry J. Dawson and Gregory E. Sutter	
The Value of Riparian Habitat and Wildlife to the Residents of a Rapidly Urbanizing Community. . . . .	413
S. Black, P. Broadhurst, J. Hightower, and S. Schauman	
LEGAL AND INSTITUTIONAL NEEDS	
Public Values for Riparian Ecosystems: Experimental Results in the West and Implications for the Grand Canyon. . . . .	417
Philip A. Meyer	
Improving Riparian Protection by Linking State Programs. . . . .	421
Michael Mantell, Philip Metzger, and Christine Reid	
Estimating the Economic Value of Recreation Resources: A Legal and Policy Perspective. . . . .	426
Stewart Allen	
Protection of Riparian Lands Through Tax Incentives. . . . .	433
Mike W. Anderson	
Streamside Management Units in the Pacific Northwest. . . . .	435
Gerald W. Swank	
The Use of Third-Party Intervenors in Negotiated Settlements: Lessons From the Past Ten Years. . . . .	439
Verne C. Huser	
An Emerging Riparian Policy in Missouri: Opportunities for Protection, Restoration, and Management. . . . .	443
Joseph P. Bachant and Richard E. Wehnes	
Managing for Multiple Resources in Western Cascades Forest Riparian Areas: An Example. . . . .	448
Jon Vanderheyden	
Dividing the Water: Basic Precepts of Colorado River Water Law. . . . .	453
David L. Wegner	
Resolving a Classic Conflict: Threat to a Riparian Ecosystem in Oklahoma. . . . .	456
John S. Barclay	

RIPARIAN ECOSYSTEMS IN DRYLAND ZONES OF THE WORLD

The Florescence of Arid Lands in Mesopotamia, Elam, and Central Asia:  
 An Historical Perspective. . . . . 463  
 Jeffrey Zauderer

The Use of Riparian Vegetation in Damascus Basin. . . . . 467  
 Mohammad S. Abido

Land Use in the Majjia Valley, Niger, West Africa. . . . . 470  
 Peter F. Ffolliott and Roy L. Jemison

Rio Yaqui Watershed, Northwestern Mexico: Use and Management. . . . . 475  
 Luis Bojorquez, Raymundo Aguirre, and Alfredo Ortega

Effects of Dryland Farming on Navajo Riparian Lands. . . . . 479  
 Jo Ann B. Jayne

Role of Riparian Vegetation in Pakistan. . . . . 482  
 Bashir H. Shah and John L. Thames

POSTER PRESENTATIONS

Annual Phenological Profiles of Plants in and Adjacent to Two Riparian  
 Habitats in Southeast Arizona. . . . . 485  
 Karen R. Adams

Riparian Habitat Restoration and Beavers. . . . . 489  
 Larry L. Apple

Riparian Ecosystems of Alaska. . . . . 491  
 Keith D. Bayha

Patterns of Reproduction in Wright's Sycamore. . . . . 493  
 Jane H. Bock and Carl E. Bock

A Weighted-Means Ordination of Riparian Birds in Southeastern Wyoming. . . . . 495  
 Deborah M. Finch

Transplanting Native Sonoran Desert Plants. . . . . 498  
 George A. Ruffner, Donald A. Fedock, and Steven W. Carothers

Recovery Processes in Southeastern Riverine Wetlands. . . . . 499  
 R. R. Sharitz and L. C. Lee

Structural Anadromous Fishery Habitat Improvement on the Siskiyou  
 National Forest . . . . . 502  
 Bruce D. Sims and Lee D. Johnson

Small Mammal Community Structure in Old Growth and Logged Riparian  
 Habitat. . . . . 505  
 Lee H. Simons

Riparian Area Management in the Pacific Southwest Region of the USDA  
 Forest Service. . . . . 507  
 Ivars J. Steinblums and Andrew A. Leven

Riparian Community Type Classification in the Intermountain Region. . . . . 510  
 Andrew P. Youngblood, Wayne G. Padgett, and Alma H. Winward

Dormant Stub Planting Techniques. . . . . 513  
 John C. York

APPENDIX

Model Riparian Habitat Protection Statute. . . . . 515

Author Index. . . . . 522

## Foreword

It gives one cause to wonder that until fifteen years ago, the term "riparian" was unknown to the majority of people, laymen and scientists alike. This is the word that is used to describe our most valuable and controversial parcels of land, which are known collectively as wetlands. It is as if there was a sudden recognition of the existence of riparian areas and the critical need to study and conserve these unique ecosystems.

The First North American Riparian Conference held in Tucson, Arizona on April 16-18, 1985 was a milestone for the riparian issue. The overlying theme "Riparian Ecosystem and Their Management - Reconciling Conflicting Uses" has brought new dimension to the international wetlands picture. Past research efforts have primarily focused on detailed but single-issued studies of biological or hydrological factors, biotic diversities, flow rates and the like. All these factors contribute to make riparian areas extremely important habitats in any environment, but their value increases significantly when you add in man's demand for these resources. These precedings deal with the complexities and contradictions of preservation and use and set the direction for the future of riparian management.

The reconciliation of the many conflicting uses of riparian ecosystems is the only way to salvage these extremely finite and decreasing habitats. It is not enough to preserve them solely for their natural values, to provide crucial habitat for avian, mammal and aquatic species and to maintain undisturbed areas for associated riparian vegetation to ebb and flourish in response to unmanipulated rivers and watersheds. These same areas are widely sought after for the building of homes, industrial sites and recreational facilities, to hunt, fish and camp in, to convert to farmlands and raise livestock, to store water for irrigation, industries and cities. The goal should be, not total protection or commercial exploitation, but balance the

conservation of riparian systems. It may not be feasible to preserve intact the whole system of which any riparian habitat is a part. Instead, managers must strive to conserve the values of riparian systems by maintaining their vital processes. This would mean preserving many riparian habitats intact, but allowing controlled use in others.

It is estimated that 45 million acres of an original total of 127 million acres of wetlands have been lost to commercial development, agriculture and other uses. Much of the remaining wetlands have been damaged by pollution, timber cutting, land drainage and other activities. The demand for wetland habitats continues to increase as does the subtle degradation of our nation's remaining riparian ecosystems.

As a result of the wealth of research and studies conducted involving riparian ecosystems, managing agencies and the public are more cognizant of the value of wetlands. Building on this awareness, action should follow.

What is needed is the implementation of a comprehensive legislative mandate for the protection, conservation and rehabilitation of riparian ecosystems. Previous efforts have addressed only pieces of the whole. Legislation must include all aspects of riparian systems and address all levels of involvement - federal, state, local and private - to be effective.

The nature of riparian systems means that jurisdictional boundaries are ignored, therefore management decisions for these important resources must include all landowners and address all possible impacts. A focused international program for protective management of riparian systems is a necessity. Our riparian lands are too important a natural resource to ignore.

Bruce Babbitt  
Governor of Arizona

# A Summary of Socio-Economic Presentations at the First North American Conference on Riparian Ecosystems and their Management<sup>1</sup>

Philip A. Meyer<sup>2</sup>

## UNIFYING TRENDS IN RIPARIAN MANAGEMENT

In considering work on riparian systems prior to this conference, and the papers presented at Tucson, two unifying trends are evident. First, as Jon Kusler and Philip Metzger point out, considerable work of a legal and organizational nature has taken place, on behalf of wetlands--primarily in the eastern United States. It is suggested that wetlands may not be riparian in nature, but that the experience gained and precedents obtained in that area will prove useful in developing organization and legislative strategies at federal, state, and local levels to protect riparian habitat. There seemed to be a consensus at the conference that such strategies should be pursued.

While effective organization and legislation will assist riparian scientific concern, it will not replace it. The commitment of riparian scientists to expanding riparian technical enquiry will need to continue, regardless of the relative success of organizational and legislative efforts. Richard E. Warner, with others, has established a standard for persistent commitment and scientific quality that we will need to emulate in that regard.

## THE ROLE OF MAN IN THE RIPARIAN SYSTEM

Focusing more specifically on socio-economic issues concerning riparian systems, one of the open issues during the 1981 Riparian Conference at the University of California, Davis was whether man should be regarded as part of the riparian system, or as a predatory intruder. The tenor of the papers presented at Tucson suggests that the issue is now largely resolved. Undoubtedly, some scientists may hold to the predatory view, but the integration of bio-physical and socio-economic dialogue at this conference seems to clearly indicate that human activities critically affect riparian systems and must be integrated into management and protective strategies. Reference to papers presented concerning the Republic of Mexico and other arid countries, where riparian systems must support a wide range of basic human needs, renders this conclusion even clearer.

---

<sup>1</sup>Paper presented at the First North American Riparian Conference. Tucson, Arizona, April 16-18, 1985

<sup>2</sup>Philip A. Meyer is president, Meyer Resources Inc., Davis, Calif.

## ISSUES OF SOCIO-ECONOMIC ANALYSIS

Four main analytical issues are raised by the socio-economic papers presented. First, virtually every paper reported that the lay public values riparian resources highly, and is seeking practical ways to preserve them. It may not know how to do this, but it wants to try. This is evident in papers presented by Sweep, Buckhouse, Foster, Kelly, and Hightower, and stands in contrast to the sometime scientific view that the public does not care and is, in that sense, the enemy of wise management of riparian systems. Such a result suggests that efforts need to be made to advance technical models that integrate scientific analysis with public concern, and that communicate more while educating less.

Second, it appears that socio-economic analysts working with riparian systems can benefit from the analytical rigor displayed by some of their bio-physical colleagues. The socio-economic papers presented provide a smorgasbord of approaches and analytical models. Some were well specified and rigorous in application, but the majority were rather general and simply reported that results were "interesting" or that "some people liked the approach." It is my impression that many social scientists working with riparian systems can markedly improve the effectiveness of their work by stating analytical objectives more clearly, by controlling their experiments and procedures more rigorously, and by reporting results more regularly. In this way we will be able, in classical experimental fashion, to modify promising approaches for obtaining improved analytical results, discard procedures that fail, and enhance the effectiveness of our scientific tools over time.

Third, and following from the issue just discussed, two general, but quite different, types of objectives seemed observable in the papers presented. To borrow from Verne Huser's field of expertise, effective negotiation requires two critical ingredients: a common perception of what pertinent data say, and appreciation of each party's strengths and failsafe points. One group of socio-economic presenters seemed to assume that strengths and failsafe points were known and agreed to, and targeted "design and mitigation" objectives. The thrust of those papers seemed to be achieving a joint design for riparian systems that was agreeable to all parties. Papers by Anderson on forest practices in Oregon, by Foster on river use in the Ozark Scenic Riverways, by Hill presenting a site signature method, and by Kelly, Dawson, Swank, Vanderheyden, and Huser seem generally to fall in this category.

A second group of papers had a quite different objective. They assumed that the basic strength of

riparian values was not known or agreed to between negotiating/contesting parties, and that establishment of such riparian values and failsafe points was their basic study objective. These analyses required quite different analytical methods and procedures, and were typified by Allen, reporting on an FERC process in Montana, by Barclay, discussing an Oklahoma riparian conflict, and by Meyer, concerning potential undervaluing of riparian systems in the Grand Canyon.

Both objectives are legitimate, but likely require significantly different analytical techniques. Differences in purpose should consequently be made clear by investigators. The study by Hightower appears to address both basic riparian values and issues of mitigative design, and is recommended.

Fourth, retention by Hightower of the riparian system as the primary socio-economic product of concern contrasts with the characteristic by characteristic overlay approach used, for example, by Hill. It is likely that these alternative approaches are appropriate to different riparian circumstances. Again, however, researchers need to consider this issue explicitly, in judging how their analyses should achieve balance between considerations of "the forest" on the one hand, and "the trees" on the other.

Finally, the paper by Jayne was the only one presenting the perspective of America's Indian peoples. With significant riparian resources located within America's Indian reservations, it appears desirable to expand this dialogue at future riparian meetings and conferences.

# A Summary of Biological and Physical Science Presentations at the First North American Conference on Riparian Ecosystems and Their Management<sup>1</sup>

David W. Crumpacker<sup>2</sup>

Among the previous symposia and conferences held on riparian topics, three are especially noteworthy for their comprehensive approach and emphasis on the relationship of ecology to management: the pioneering regional symposium in Tucson, Arizona on "Importance, Preservation and Management of Riparian Habitat" (Johnson and Jones 1977), the first national symposium, "Strategies for Protection and Management of Floodplain Wetlands and other Riparian Ecosystems" (Johnson and McCormick 1978), and the massive regional symposium on "California Riparian Systems: Ecology, Conservation, and Productive Management" (Warner and Hendrix 1984) which was held in Davis, California in 1981. The present conference continues this tradition in a North American context with some additional consideration of riparian ecosystems on other continents. Many topics were discussed this past week. Some will be mentioned here to illustrate current trends in riparian thought, using in most cases the previously mentioned symposia as a basis for comparison.

The trend toward increased emphasis on the socioeconomic aspects of riparian issues, begun at the Davis symposium in 1981, was strengthened. The degree to which riparian ecosystems will eventually be conserved depends ultimately on the importance of their natural qualities to humans rather than to vegetation, wildlife, and livestock. This crucial point was clearly understood and emphasized in a series of papers that have been summarized by Meyer in these proceedings.

Continuing emergence of the riparian concept is an issue of great importance that was highlighted by Kusler in his call for increased emphasis on protection of riparian habitat in the

arid and semiarid west. Both U.S. regional and national perceptions are lacking on the unique values of riparian ecosystems. Many of these systems are not legally wetlands but are equally valuable. The scientific basis for defining riparian ecosystems and describing their resources is reasonably well developed. A challenge to natural scientists now is to aid in transferring this knowledge to federal, state, and local governments, and to private organizations and citizens.

The scientific basis for understanding the processes that take place in riparian ecosystems is less well documented and must continue to be developed. This type of information is essential to predicting and mitigating changes in the structure and function of riparian systems that are expected to occur with or without increased human intervention. An important part of the natural science papers presented during the past week dealt with this topic.

One dramatic example of successful riparian technology transfer concerns the public attitude towards phreatophytes in the southwestern U.S. Emphasis has shifted markedly from the negative opinion of water-loving plants held by numerous public and private development groups prior to the 1970's, and still in evidence at the time of the 1977 Tucson symposium, to an interest in preserving the integrity of western U.S. riparian ecosystems through enlightened multiple-use management. Thus papers were presented in Tucson, 1985 on studies of methods by which, and the degree to which, ground water can be exported from riparian ecosystems without endangering them, and on the need for more accurate determinations of evapotranspiration from riparian systems (e.g., some previous estimates were too high). Taylor and Barclay's paper on stream renovation rather than channelization as a flood control alternative illustrates another positive attitude change with regard to riparian ecosystems, since this approach attempts simultaneously to achieve cost savings conserve wildlife, and maintain an aesthetic natural environment.

---

<sup>1</sup>Paper presented at the First North American Riparian Conference, "Riparian Ecosystems and their Management: Reconciling Conflicting Uses," Tucson, Ariz., April 16-18, 1985.

<sup>2</sup>David W. Crumpacker is a Professor of Environmental, Population and Organismic Biology, University of Colorado, Boulder, Colo.

While the earlier symposia gave considerable attention to the documentation of riparian ecosystem impacts and losses, emphasis shifted in the present conference to consideration of methods by which impacts can be mitigated or avoided. This was especially evident in several reports on effects of livestock grazing. The more anecdotal studies reported at some previous conferences and symposia, often supported only by general observations and photographs, are now being replaced by more carefully designed experiments that are beginning to produce some interesting results. For example, eight years of research on several grazing systems in northeastern Oregon showed a generally rapid enhancement of herbaceous riparian productivity when not more than 70 percent of the herbaceous forage was removed annually. A three-year study in southwestern Montana indicated that time of grazing (in relation to soil moisture) caused much more trampling damage in the riparian zone than did the amount of livestock use. The potential for purposeful use of livestock to create improved riparian conditions (positive impacts) was suggested in two papers, one involving changes in bank morphology of an ephemeral stream in Wyoming and the other dealing with changes in the vegetative structure of shrub-willow habitat in Colorado caused by livestock tunneling. Other livestock use reports included an unusual documentation of the interactive effects between grazing and major storm events on small stream corridors in Utah and Nevada and a description of the use of large scale color infrared photography combined with ground truth to spot problem riparian sites over large rangeland areas.

Recent theoretical discussions of island biogeography (e.g., Soulé and Wilcox 1980, Harris 1984) and the importance of riparian zones to forest wildlife (e.g., Thomas 1979) have created new interest in the potential benefits to terrestrial wildlife of riparian buffer strips left after timber harvest. This was reflected in the discussion of ongoing experiments to evaluate the effects of streamside riparian zones of mixed conifer forests in Oregon and streamside management zones ("stringers") in the pine forests of eastern Texas. The benefits to aquatic systems of riparian buffer strips have been thoroughly described in the past. However, an interesting paper by Heede discussed the positive potential of tree fall from buffer zones on the natural dam building tendencies of mountain streams.

Two types of riparian ecosystems not given much previous attention were emphasized at Tucson in 1985: those adjacent to or otherwise dominated by cropland agriculture and those subject to extreme aridity. The effects of croplands on avian diversity in the riparian areas of the lower Colorado River bordering Arizona and California were discussed by Ohmart et al. with respect to waterbirds, waders, and shorebirds, and an interesting description was given of a large Arizona pecan orchard as a special type of riparian ecosystem. In both

cases it was noted that riparian ecosystems (natural or artificial) can undergo drastic changes in wildlife diversity over a relatively short time due to economic factors associated with cropping systems. Several papers discussed ideas or presented data related to xeroriparian ecosystems, thereby elaborating on a concept developed by Lowe (1961) and Johnson et al. (1984). The extreme importance of these desert riparian habitats to wildlife and the obligate riparian nature of some of their otherwise facultative riparian plant species are interesting features of xeroriparian ecosystems.

There continue to be important gaps in our knowledge of the basic biology of riparian plant species and communities. No trend toward rectification of this problem was detected during the past week, as only a few presentations were given in this area. Interaction of flooding regimes with successional processes of riparian forests in New Mexico and Arizona and with patterns of reproduction in Wright's sycamore (*Platanus wrightii*) in southeastern Arizona were discussed in separate papers. The major factors affecting regeneration of a southeastern U.S. hardwood forest riparian ecosystem (mature cypress-tupelo) were described and the need to consider these factors in management of floodplain water levels was stressed. A preliminary study of the annual phenological profiles of several plant species growing in two riparian habitats of southeastern Arizona was also reported.

Inclusion of an entire conference section on riparian herpetofauna marked an important departure from the three previous symposia mentioned earlier which contained only one paper that featured this topic (Brode and Bury 1984). Lowe's suggestion that Arizona's obligate riparian species of amphibians and reptiles be accorded special status (e.g., "threatened") as soon as possible dramatized the fact that little time remains to save these populations before most of their habitats are seriously modified or lost.

Several reports involving ecological surveys were based on carefully controlled designs and large data sets, thereby indicating the continuing maturation of riparian ecology as a science. Examples of these were the detailed study by Knopf of relationships between riparian and upland bird populations along an extensive altitudinal transect in northeastern Colorado and an investigation by Hunter et al. of avian responses to salt cedar (*Tamarix chinensis*) in three major southwestern U.S. riverine systems. Both studies have important managerial implications, the former with regard to altitude as a factor in determining the value of riparian zones to birds and the latter with respect to the somewhat unpredictable interactions between major riverine ecosystems and specific plant community types in determining use of the latter by avian species.

A trend toward increased efforts to model the structure and function of riparian ecosystems was



evident at the 1985 Tucson conference. This may be partly a result of the development of riparian data bases that make some modeling efforts possible and partly due to the greatly increased access to, and familiarity with, computerized techniques that has occurred in the past five years. However, the orientation of some of these models towards planning and decision making also suggests that riparian scientists are becoming more cognizant of the need to integrate the natural and social aspects of riparian ecosystem management. Examples include the "second generation" of simpler models devised by Ohmart and colleagues that relate wildlife species to vegetative parameters for use in mitigating wildlife impacts through revegetation, Short's description of habitat structure in terms of habitat layers to provide simple riparian habitat impact prediction models, and the watershed modeling of nutrient levels and effects of riparian vegetation on water quality in the southeastern United States. Additional modeling efforts stressing aquatic components of natural systems included an attempt to conceptualize the effects of beavers on lower order streams and a more detailed treatment of instream and riparian cover in the prediction of trout biomass, both in the context of Wyoming streams.

The attempt of the conference to address riparian issues throughout all of North America was modestly successful and it was especially good to have some descriptions of riparian ecosystems in Mexico and Alaska. Discussions of Canadian riparian ecosystems and issues were conspicuously lacking. Perhaps a Second North American Riparian Conference can be held that will include more information on Canadian, Mexican, and Central American riparian topics.

Those of us who attended the First North American Riparian Conference are greatly indebted to its technical coordination committee and especially to Roy Johnson who guided it from inception to successful completion. Besides the accomplishments of the formal program, this conference provided an opportunity for Roy to direct the formation of a "North American Riparian Council." Goals of the council are now being formulated, a charter is being developed, and alliances with other public and private organizations that have riparian interests will be sought. "Extracurricular" activities of this sort, together with the establishment and re-establishment of personal contacts, are always part of a successful conference and may in some instances have more lasting impact than any one of the professional presentations.

#### LITERATURE CITED

- Brode, J.M., and R.B. Bury. 1984. The importance of riparian systems to amphibians and reptiles. p. 30-36. *In* R.E. Warner and K.M. Hendrix (Ed.), California riparian systems: ecology, conservation, and productive management. [Based on proc. of conf. at Davis, Calif., Sept. 17-19, 1981.] 1035 p. Univ. Calif. Press, Berkeley, Calif.
- Harris, L.D. 1984. The fragmented forest - island biogeography theory and the preservation of biotic diversity. 211 p. Univ. Chicago Press, Chicago, Ill.
- Johnson, R.R., S.W. Carothers, and J.M. Simpson. 1984. A riparian classification system. p. 375-382. *In* R.E. Warner and K.M. Hendrix (Ed.), California riparian systems: ecology, conservation, and productive management. [Based on proc. of conf. at Davis, Calif., Sept. 17-19, 1981.] 1035 p. Univ. Calif. Press, Berkeley, Calif.
- Johnson, R.R., and D.A. Jones (Tech. Coord.). 1977. Importance, preservation and management of riparian habitat: a symposium. [Tucson, Ariz., July 9, 1977.] USDA For. Serv. Tech. Rep. RM-43, 217 p. Rocky Mt. For. and Range Exper. Sta., Fort Collins, Colo.
- Johnson, R.R., and J.F. McCormick (Tech. Coord.). 1978. Strategies for protection and management of floodplain wetlands and other riparian ecosystems. [Proc. symp., Callaway Gardens, Ga., Dec. 11-13, 1978.] USDA For. Serv. Gen. Tech. Rep. WO-12, 410 p. USDA For. Serv., Wash., D.C.
- Lowe, C.H., Jr. 1961. Biotic communities in the sub-Mogollon region of the inland southwest. *J. Ariz. Acad. Sci.* 2(1): 40-49.
- Soulé, M.E., and B.A. Wilcox (Ed.). 1980. Conservation biology: an evolutionary - ecological perspective. 395 p. Sinauer Associates, Sunderland, Mass.
- Thomas, J.W. (Tech. Ed.). 1979. Wildlife habitats in managed forests - the Blue Mountains of Oregon and Washington. USDA For. Serv. Agric. Handb. No. 553. USDA For. Serv. in coop. with Wildl. Manage. Inst. and USDI Bur. Land Manage., Wash., D.C.
- Warner, R.E., and K.M. Hendrix (Ed.). 1984. California riparian systems: ecology, conservation, and productive management. [Based on proc. of conf. at Davis, Calif., Sept. 17-19, 1981.] 1035 p. Univ. Calif. Press, Berkeley, Calif.

# A Call for Action: Protection of Riparian Habitat in the Arid and Semi-Arid West<sup>1</sup>

Jon A. Kusler<sup>2</sup>

## INADEQUATE PROTECTION

"Riparian habitat" in the arid and semi-arid West is a vanishing resource equal to or greater in value than the wetlands of the Midwest, East, and South. The fact is that despite a great deal of discussion and the conduct of several national riparian habitat symposia, there has been little protection. Huge acreages continue to be destroyed each year in the 20 states west of the Mississippi due to urbanization, flood control (drainage, levees), diversion of ground and surface waters, agriculture, grazing, acid rain, and other pollution.

The scientific base documenting the wildlife, flood control, water pollution, erosion control, fisheries, and recreational values of riparian habitat has been strengthened in the last five years, yet there are no systematic protection policies or procedures at any level of government:

### Federal

At the federal level, riparian habitat protection policies have been adopted by the Forest Service and BLM. But these policies are only partially implemented. The floodplain management and wetland protection Executive Orders which apply to public land management also protect some riparian habitat but are limited in their coverage. The Section 404 permit program implemented by the U.S. Army Corps of Engineers with E.P.A. and the Fish and Wildlife Service partially applies since permits are required only for discharge into "waters" and adjacent "wetlands." But most of the riparian habitat in the arid West does not meet the strict regulatory test for "wetlands."

Rather than protect riparian habitat, federal construction and subsidy programs have often encouraged its destruction. These include flood control projects and flood insurance subsidies, irrigation and other water projects and subsidies, and agricultural subsidies.

---

<sup>1</sup>Paper presented at the First North American Riparian Conference, Riparian Ecosystems and Their Management: Reconciling Conflicting Uses, April 16-18, 1985, Tucson, Arizona.

<sup>2</sup>Chairman, Association of State Wetland Managers, Chester, Vermont.

### State

At the state level, there are also no overall protection policies. No state east of the Mississippi has adopted a comprehensive wetland or riparian habitat protection program for public or private lands, unlike the coastal states which have all adopted some protection for their coastal wetlands and 11 eastern states which have adopted fresh-water protection statutes. Oregon has taken an important step in protecting riparian habitat by adopting both planning guidelines for riverside lands and a state tax credit program. Six western states have adopted floodplain regulatory laws--California, Montana, Washington, Oklahoma, Nebraska and Colorado--but these are narrowly aimed at reducing flood losses and have no provision for vegetation.

### Local

At the local level, thousands of communities in the West have adopted floodplain zoning laws, but only a handful have incorporated riparian habitat protection provisions. This handful includes communities such as Boulder, Colorado and Sacramento, California.

### Private Landowner

At the private landowner level, some individuals and corporations (e.g., duck clubs) have protected habitat, but this has been accomplished with limited technical assistance and information "on best management practices." Federal and state development-oriented financial incentives have often discouraged protection.

## WHY A LACK OF PROTECTION POLICIES?

The lack of coherent riparian habitat protection policies at any level of government is only partially due to competing land uses. Development and agricultural interests are, of course, powerful. But there are other reasons.

First, most riparian is not considered "wetland." In formulating wetland definitions at the federal level, "riparian habitat" was not included. Wetlands have been defined for the purposes of Section 404, the National Wetland Inventory and National Wetland Classification System, the Wetland Protection Executive Order and most other wetland programs and

initiatives in terms of saturated conditions. Much of the riparian habitat in the East and Northeast qualifies as wetland by this definition. But the majority of riparian habitat in the arid and semi-arid West does not. In dry areas, riparian habitat is "wet" in comparison to adjacent lands, but not wet enough to qualify as wetland (as defined in the East).

Second, legislators, interest groups, and landowners have not received specific enough guidance from the scientists and the land managers with regard to

- specific types of land and vegetation needing protection,
- the reason for protecting these areas,
- the types of uses needing regulation and the standards necessary to achieve such protection.

#### RECOMMENDATIONS

What can be done to strengthen riparian habitat protection?

An Effort Must Be Made to Clear Away the Semantic Clouds

Precision in thinking and terminology is needed. Efforts to convince Congress, eastern scientists, and federal agencies that western riparian habitat is, in fact, "wetland" are likely to fail in light of the recent effort to reach agreement on the definition of wetland for the Wetland Classification System, Section 404 regulations and other purposes. Protection of western riparian habitat should be advocated on its own--as a class of lands similar to and as valuable as wetlands--but not meeting strict wetland definitions. Those interested in protecting riparian habitat should begin with basics: which lands need to be protected and why?

Distinctions Should Be Made Between Major Categories of Riparian Habitat

Riparian habitat throughout the nation shares certain characteristics:

- location on "riparian" lands along streams, rivers, arroyos, ponds, lakes, other water bodies;
- growth of vegetation dependent upon relatively high soil moisture content;
- periodic flooding;
- alluvial or other characteristic soils (some, but not all lands);
- special water-related functions such as erosion control;
- special management needs.

But there are major differences between eastern and western riparian habitat. In the East, riparian habitat is often wet enough to actually qualify as "wetland." Eastern fish and game

management personnel often view stream-side habitat as not as important, from a waterfowl perspective, as classic cattail marshes. Consequently, riparian habitat is not often viewed nationally (in the East, Northeast, Midwest and Northwest) as particularly valuable. In contrast, in the West, riparian habitat is much dryer and does not qualify as wetland although it may play an equally important or more important role (in a relative sense) than eastern wetlands for fisheries, wildlife, pollution control and other wildlife.

A distinction between Eastern and Western riparian habitat protection needs is desirable if protection is ever to be achieved in the Western states.

Protection Efforts Should Focus Upon the Lowest Common Denominator for All Protection Programs--Management Guidelines for Uses Which Threaten Such Lands

Universities, agencies, or interest groups should develop guidelines and handbooks pertaining to agriculture, grazing, flood control, urbanization, and other uses to reduce the impacts of uses and, in some instances, promote the reestablishment of vegetation in denuded areas. Management handbooks should document success stories in protecting and enhancing riparian habitat.

The Riparian Habitat Science Base Should Be Summarized, Gaps in This Base Identified, and a Coherent Research Program Proposed to Fill Those Gaps

Existing studies should be summarized with regard to the state of knowledge pertaining to riparian habitat values and protection needs. The scientific basis for various management practices should also be summarized.

A similar science-assessment effort is now underway by the U.S. Army Corps of Engineers for "wetlands" at the Corps Vicksburg Laboratory which could serve as a model for such an assessment. Once research gaps were identified, a coherent federal, state, and university research program should be proposed to fill the gaps.

Opportunities for Protection Should Be Simultaneously Pursued at All Levels of Government

There will be no magic solution to riparian habitat protection. A partnership effort is needed at all levels of government, building upon existing efforts and with some new initiatives.

Federal.--Improved and more specific federal riparian habitat protection guidelines are needed. Guidelines already in existence in BLM and the Forest Service should be given added specificity. Explicit riparian habitat protection guidelines should also be incorporated into the U.S. Army Corps of

Engineers Section 404 guidelines since habitat is "water of the U.S." although it may not qualify as wetland. Riparian habitat protection guidelines are also needed for federal construction projects and subsidies for agriculture, water projects and flood control. Perhaps Congress should consider termination of subsidies which destroy habitat much as it has done with the Barrier Resources Act for coastal barriers.

State.--State agencies need to develop and incorporate riparian habitat protection guidelines into their public land management policies and into their permitting systems for instream flow. State legislatures also need to adopt new riparian habitat protection laws for the riparian corridor. These might take the form of tax incentives, public acquisition and restoration programs, and regulatory programs. New legislation could be modelled (in part) after similar wetland protection and shoreland corridor zoning laws in the midwest and east. I and the Association of State Wetland Managers are presently drafting a model riparian habitat protection law which may be of some use.

Legislatures also need to provide funding and incentives for mapping, technical assistance and education for local governments and private landowners.

Local.--Local riparian habitat protection planning is needed as part of local land use planning and land use regulatory and management efforts. Protection policies could be implemented through

- upgraded floodplain regulations with riparian habitat protection provisions;
- stream corridor protection ordinances setting forth multipurpose goals and development guidelines; and
- broader zoning, subdivision controls, building codes and other special codes establishing setbacks, tree-cutting and other vegetation removal restrictions, restrictions on filling and grading, and performance standards for uses within riparian habitat areas.

In many urban areas, riparian habitat areas may best be used as "greenways." Restoration as well as control of new development is needed. Private landowners should be given guidance with regard to land management practices.

A Coalition of Interest Groups, States, Researchers and Others Concerned with Riparian Habitat Protection Should be Formed to Help Define Protection Goals, Disseminate Information, and Work for Specific Habitat Protection Legislation

The time is ripe for a coordinated riparian habitat protection effort. The symposium and the National Riparian Habitat Council suggested by Roy Johnson can be an important start. A political-action coalition similar to the one assembled for barrier islands is also needed.

For success, coordinated western state leadership is essential. Without such coordination and a concerted protection effort, large-scale riparian losses will continue. The time for action is now.

(See Proceedings Appendix, p. 515, for the text of the proposed model Riparian Habitat Protection Statute. -- Ed.)

# Riparian Ecosystems in Mexico: Current Status and Future Direction<sup>1</sup>

Miguel Caballero Deloya<sup>2</sup>

---

An increasing population dependent on subsistence agriculture threatens the future of Mexico's extensive riparian ecosystems. If these strategic ecosystems are to survive to provide goods and services for future generations, both the Mexican government and society as a whole must be involved in an effort to: (1) evaluate present conditions, including causes of habitat destruction; and (2) generate specific legislation to establish reforestation programs and protective measures.

---

## INTRODUCTION

Mexico is a nation covered by numerous mountain ranges. The most important are: Western Sierra Madre, Eje Neovolcanico, Eastern Sierra Madre, and Southern Sierra Madre. Many other smaller mountain systems are scattered over the Mexican geography. Several peaks have elevations above 4,000 m (12,000 ft).

Such a wide orographic diversity has favored the existence of abundant riparian ecosystems. According to Tamayo (1962) there are 172 major water courses in Mexico. Half of them (86) flow to the Pacific Ocean. In all of them, an average volume of 375 billion cubic meters of water flow yearly. In addition to the Pacific Ocean, the two other major drainage systems are the Atlantic Ocean and the Interior Basin.

It is worth mentioning that the Mexican national tree, the "ahuehuete" (Taxodium mucronatum) is characteristically the most widespread community component of riparian habitats of subtropical and temperate climates.

Despite their abundance, riparian habitats have received limited attention. Political, financial, and scientific efforts have been directed to those ecosystems which exert the greatest effect on rural community development, those which impact most on agricultural and forage production nationwide, or those which occupy the greatest amount of land.

In the following pages, a brief discussion is presented on the nature and characteristics of the Mexican riparian habitats, the most important problems they face, and what their perspectives are for the coming years.

---

<sup>1</sup>Paper presented at the symposium, Riparian Ecosystems and Their Management: Reconciling Conflicting Uses, April 16-18, 1985, Tucson, Arizona.

<sup>2</sup>Director General, National Institute of Forestry Investigations, Secretary of Agriculture and Water Resources, Mexico City, Mexico.

## TYPES OF MEXICAN RIPARIAN ECOSYSTEMS

The remarkable variation in climate, altitude, and soils, has provided for a notable diversity of riparian habitats in Mexico. For the purposes of this discussion, only three major types are considered: arid-land, high-altitude, and tropical riparian ecosystems.

### Arid-Land Riparian Ecosystems

From a broad perspective, Mexico is an arid nation. The Mexican National Forest Inventory provides an estimate of 67.44 million hectares of arid and semi-arid lands in the country (Subsecretaria Forestal. 1984. p. 13).

In arid regions, riparian ecosystems are usually distinct from other habitats. Rivers and water deposits are mostly seasonal, but water availability in riparian ecosystems is higher. In these conditions, vegetation is more abundant as a response to more favorable growing conditions. Shreve and Wiggins (1964) report for the Gulf of California coastal lands, along the Baja California Peninsula, a denser vegetation on the water courses. Principal species include Prosopis juliflora var. torreyana, Prosopis palmeri; Olneya



Fig. 1.--Amacuzac river, in the dry lands of Guerrero State.

tesota; Cercidium floridum, Hymenoclea pentalepis, and Haplopappus sonorensis, among others.

Coyle and Roberts (1975) include the following species as characteristic of riparian habitats in Baja California: Anemopsis californica, Arundo donax, Platanus racemosa, Juncus sp., Populus fremontii, Salix laevigata, Salix chilensis, Typha sp., Washingtonia filifera, and Washingtonia robusta.

In the Chihuahuan desert, Salix chilensis and some species of the genus Populus are frequent along permanent river courses. Along ephemeral water courses, Schinus molle ("pirul"), Chilopsis longipes ("mimbre"), Celtis pallida ("granjeno"), Prosopis juliflora ("mezquite") and Baccharis glutinosa ("jarilla") are most representative.

#### High-Altitude Riparian Ecosystems

These ecosystems occur along the mountain ranges or in the high interior lands such as the "altiplano" in central Mexico. They are usually found at elevations higher than 6,500 ft. (2,000 m). Some of the common species in these ecosystems are: Baccharis glutinosa, Salix taxifolia, and Taxodium chilensis. Along the river courses in the Chihuahuan Sierras, Acer brachypterum and Platanus wrightii are conspicuous components.

Rzedowski (1978) reports the genera Platanus, Populus, Salix, Acer, Alnus, Carya, and Fraxinus among others in the gallery forests of this type up to an altitudinal limit of 9,186 ft. (2,800 m).

Certain species typical of other types of habitats (usually drier) are frequently found in abundance in riparian habitats. That is the case with Casuarina equisetifolia, Eucalyptus spp., and different species of pines, in the Central High Basin (Altiplano Central).

Many high-altitude riparian ecosystems are located within conifer forests. In the case of conifer stands characterized by low precipitation, firs tend to predominate over pines along the water courses. A typical pine characteristic of those ecosystems is Pinus ayacahuite, a species with great demand for pulp production.

In the northern States of Chihuahua and Durango, Picea chihuahuana behaves as a typical riparian species along the mountain ranges.

#### Tropical Riparian Ecosystems

Tropical regions are characteristically in east and southeast Mexico. Most of them occur in the States of Campeche and Quintana Roo in the Yucatan Peninsula, and southeastern Chiapas, a Guatemalan border State. Other tropical forests can be found along the coastal plains of both the Gulf of Mexico and the Pacific Ocean. The Mexican National Forest Inventory has estimated an area of 13.2 million hectares covered by tropical forests.

The high precipitation characteristic of these regions is responsible for the existence of several important rivers. Those rivers and their tributaries concentrate large numbers of riparian ecosystems. Tropical riparian systems contrast with those of arid and high-altitude regions. The majority of the rivers in tropical Mexico have a continuous water flow throughout the year, even though the amount of flow varies seasonally. This characteristic, plus the fact the tropical habitats occur at low elevations (usually below 500 m) create special conditions that determine the amount and type of vegetation. Some of the most widely distributed species in these types of ecosystems are: Ficus spp. ("amates"), Lonchocarpus hondurensis ("gusano"), Inga spuria ("cuajinicuil"), Pachira aquatica ("zapote"), Pithecellobium arboreum ("coralillo"), Astianthus viminalis, and Guadua aculiata.

Some trees characteristic of temperate and subtropical regions frequently occur in tropical riparian ecosystems. Examples are Salix chinensis ("sauz"), Platanus chiapensis ("tatacuil"), and Taxodium mucronatum ("ahuehuete"), which are present along the riparian lands of the Nepac river, Chiapas.

In subtropical and transitional riparian ecosystems, the following species are characteristic: Populus spp., Alnus arborea, and Platanus spp. Among pine species, Pinus chiapensis is perhaps the most representative in east and southeast Mexico (Guerrero, Chiapas, and Veracruz).

#### IMPORTANCE OF RIPARIAN ECOSYSTEMS

The importance of Mexican riparian ecosystems can be analyzed from three perspectives: provision of goods and services, preservation of endemic vegetation and wildlife, and water regulation and flood control.

##### Provision of Goods and Services

Many riparian ecosystems play a relevant role for the subsistence of rural communities. In arid lands, they provide productive sites in non-irrigated lands for agricultural production. In the dry lands of the States of Hidalgo, Tlaxcala, and Puebla, in central Mexico, numerous small patches of cultivated Agaves and Opuntias can be observed in lands adjacent to dry river courses. Frequently, these lands offer the only alternative for crop production. Where conditions are more favorable, apple and other fruit trees are established.

Riparian sites are commonly appreciated for their scenic and recreational value. "El Contador" national park in Texcoco, State of Mexico, is a typical riparian ecosystem with abundant beautiful "ahuehuetes" (Taxodium mucronatum). The "Barranca de Cupatitzio" park in Uruapan, Michoacan, is another example of the beauty of a riparian ecosystem and its importance to society from a recreational point of view.

Riparian ecosystems also help support rural communities by providing goods which are basically consumed locally and occasionally sold in regional markets. Examples include fuelwood, wildlife, fruits, edible plants, forage, and ornamental plants.

In some regions, riparian habitats are being rapidly transformed to establish new human settlements. The rate of this transformation is greatest in the Central Plateau, where the demographic explosion is the highest in the nation.

#### Preservation of Endemic Vegetation and Wildlife

Because of their unique natural features, riparian ecosystems have favored the existence of endemic plants and animals. Due to the rate of destruction of these habitats, and the narrowness of their natural distribution, some species are now endangered. This is the case of Acer brachypterun in the States of Chihuahua and Sonora, Picea chihuahuana in Chihuahua and Durango, and some species of Platanus in transitional regions. In some regions, riparian ecosystems play an important role for germplasm preservation.

The eagle is an endangered species in most of Mexico. One reason is the destruction of its natural habitat. Another reason is the intense hunting of the species by rural inhabitants.

#### Water Regulation and Flood Control

Even though there is little information available in Mexico, it is clearly recognized that riparian ecosystems are important water flow regulators. Evidently, riparian vegetation plays an important role in this regulation, depending on frequency, timing and intensity of flooding. Much has to be learned however, about the nature of these interactions.

### PROBLEMS AND LIMITATIONS

#### Contamination

Riparian contamination occurs in two ways. The first is the result of industrial residual discharge. This is the typical case with the sugar industry, pulp and paper plants, refineries, breweries, and textile, fertilizer, and chemical plants. In the States of Tabasco, Veracruz, and Tamaulipas, contamination by oil extraction and processing is becoming a major concern. In other regions, contamination by organic effluents (stools) has become a problem. Important rivers, such as the Coatzacoalcos, Blanco, Zahuapan, Atoyac, Lerma, and Panuco, to cite a few, reflect different degrees of pollution by the causes cited above (Urroz, 1973).

In 1973, the sugar industry was the most important organic contaminator of Mexican rivers. This industry generated 34 percent of organic pollutants found in the rivers that year. The chemical industry followed in importance.



Fig. 2.--Contamination by garbage disposal on the Oacapa river, Guerrero State.

Another form of riparian contamination occurs mainly in the most populated region of the country, the Central Plateau, where many river ditches--mainly near urban centers--are used as garbage disposal areas. The Panuco and the Lerma are probably the most contaminated rivers by this and industrial wastes.

#### Unplanned Wildland Conversion to Agricultural and Forage Production

Population growth in Mexico is exerting greater pressure on natural resources. Lands for agricultural and forage production are increasingly demanded. As a consequence of this pressure, the agricultural frontier is growing by destruction of natural habitats, such as forest and riparian lands. This uncontrolled land use conversion is affecting the ecological equilibrium of those sites affected. Silting of rivers and wildlife mortality are some of the negative results.

#### Destruction of Endemic Biota

As previously mentioned, riparian ecosystems in Mexico have been important providers of goods and services, of high value to local communities. The increasing exploitation of some of these goods, most of them provided by endemic flora and fauna, is causing severe damage to the biota. Trees that supply fuelwood and wood for other domestic uses, and species that provide forage have been most affected.

By the same token, wildlife species customarily consumed by humans reflect a dramatic depletion, as do those species that affect domestic animals. In the first group, the white-tailed deer and turkey are probably most affected. The second group includes coyotes and falcons among others.

#### THE FUTURE

Present trends pose serious doubts and concern about the future of Mexican riparian ecosystems. Particularly in areas of denser

population, riparian destruction is most evident. Despite this fact, little information exists on the problem, and apparently no strategy at a national level has been applied in Mexico to solve it.

If Mexican riparian ecosystems are to be preserved for the enjoyment and utilization of future generations, then several urgent tasks should be started. Some of them are listed below.

1) A national survey should be conducted to evaluate present conditions of the most important riparian ecosystems in the nation. Such an evaluation should include not only the level of habitat destruction, but information on agents causing the damage.

2) With the information gathered through the survey, regional policies and actions should be established to preserve or restore endangered and affected ecosystems. These include:

- Specific legislation
- Reforestation programs
- Protective measures (stabilization work, erosion control, etc.)

The challenge, however, is to control the increasing demographic impact, which affects not only riparian ecosystems, but all natural resources. For this purpose, during the present public administration the Secretary of Urban Development and Ecology was created. This agency has a highly important historical responsibility, and will have to face some of the most complex problems that affect the present Mexican society. It should be recognized, however, that no matter

what actions and policies are taken by State organizations, little will be gained to stop natural resource destruction if the total Mexican society is not involved in its conservation. Much effort will have to be devoted by governmental agencies in educating and creating consciousness in the citizenship about the importance and vital role of natural resources in their well being and that of future generations.

#### LITERATURE CITED

- Coyle, J. and N.C. Roberts. 1975. A field guide to the common and interesting plants of Baja California. Nat. Pub. Company. La Jolla, Cal. U.S.A. 206 pp.
- Rzedowski, J. 1978. Vegetacion de Mexico. Edit. Limusa, S.A. 1a. Ed. Mexico.
- Shreve, F. and T.L. Wiggins. 1964. Vegetation and Flora of the Sonoran Desert. Vol.I. Stanford University Press. Stanford, Cal. U.S.A.
- Subsecretaria Forestal. 1984. Mexico Forestal. Cifras 1983. Secretaria de Agricultura y Recursos Hidraulicos. 59 pp. Mexico.
- Tamayo, Jorge L. 1962. Geografia General de Mexico. Inst. Mex. de Invest. Economicas. Tomo II. 2a. Ed. Mexico.
- Urroz, E. 1973. Programa Nacional Contra la Contaminacion del Agua. Proceedings of the First National Meeting of Environmental Contamination Problems. p. 51-54. Mexico.



# Thinking Laterally: Strategies for Strengthening Institutional Capacity for Integrated Management of Riparian Resources<sup>1</sup>

C. David Loeks<sup>2</sup>

---

Abstract.--The primary goal of environmental management is to maintain the capacity of the environment to meet human needs and aspirations. This goal is best achieved when environmental management is both integrated and differentiated. Efforts to manage differentiated environmental resources such as riparian ecosystems are most successful when they are integrated with the management of larger environments which subsume the relevant factors that affect the differentiated resource. General strategies to strengthen institutional capacity to achieve such integration in the management of riparian resources are discussed.

---

## INTRODUCTION

The main argument of this paper can be summarized in five basic points.

1. The impacts of activities associated with human settlement generate the primary source of stress on riparian resources. Managing such impacts are the primary concern of riparian resource management.
2. However, in many cases, the activities which generate the impacts on specific resources can't be managed "on-site". Such impacts are "driven" by social and economic and physical development forces and imperatives which transcend the scope of concern of the specific resource being managed and therefore the institutional responsibilities of its managers.
3. Adequate institutional resources and capabilities are not in place for integrating the management of a specific resource such as a riparian ecosystem with the strategic management of the environment as a whole.
4. The acquisition of the institutional resources and capabilities for more integrated management of the environment as a whole should be a matter of primary concern. Without such capacity, efforts to manage individual components of the environment such as riparian resources are severely limited, and in some cases, doomed to failure.

5. We can do better. In an open, pluralistic society, the strategic generation and dissemination of scientifically based knowledge which clarifies environmental interdependencies in ways in which affect public perception and will to act, is an essential precondition for creating the institutional resources and capabilities required for Integrated Riparian Resource Management (IRRM).

There. I've put my cards on the table. My premises are that IRRM is a good thing, we don't have it, that we would be better off if we did, and that we can and should do better than we are doing.

In summary, the objectives of this paper are threefold. They are: (1) to discuss the need for strengthening institutional capacity for IRRM; (2) to identify some preconditions for achieving the institutional capacity for IRRM and (3) to suggest some strategies for the strengthening of such institutional capacity.

Also, a comment concerning the vantage point from which I speak is in order. My field is urban and regional planning. My intellectual concerns are with the processes of policy and design which clarify the ends to be pursued and the means to be employed in maintaining the capacity of the environment to meet human needs and aspirations. Although my intellectual concerns are as broad as the topics subsumed by the human condition that we are trying to improve, my technical competence is not in physical science. Rather, it is in the coordinated use of policy and design in the context of management to resolve resource allocation conflicts that reflect competing values involved in the use and adaptation of the environment.

---

<sup>1</sup>Paper presented at the First North American Riparian Conference - Riparian Ecosystems and Their Management Tuscon, Ariz. April 16-18, 1985.

<sup>2</sup>Professor and Chairman, Graduate Program in Urban and Regional Planning, VPI & SU, Blacksburg, VA.

My focus is normative. That is, I'm concerned with the development of consensus about the "ought" statements. My ability to do this is totally dependent on the intellectual products of science which focus on the substantive or "is" statements concerning what we have, how it works, how it got that way, and how it is changing and might change in the future. I am not one of those who argue that scientific inquiry should be constrained by pragmatic considerations or that its justification must depend upon a demonstration that it solves human problems. However I will cheerfully confess to the bias that it's perfectly alright if science is used for that purpose. Incidentally, since segments of the scientific community are of different minds on this issue, this is not a viewpoint that I urge upon junior tenure tracking science faculty colleagues in my university. However, because the title of this conference comes right out and uses the word management (gasp!), I am sustained by the assumption that there are enough people in this room who feel that it is ok to do science to solve human problems that we can have a fruitful inter-professional dialog on this subject. In any event, I just want to make it clear that it is not within my professional competence nor my intent to explain how to manage riparian ecosystems. Rather, I wish to discuss how over time we might acquire the institutional capacity to make it possible to manage such systems in more integrated and therefore more effective ways.

THE NEED FOR IRRM

At the risk of sounding pedagogic let's start with some basic definitions of the terms used in the consideration of this topic. First, environment. In its broadest ecological sense it denotes the totality of things, forces or conditions that act upon or influence an organism or a group of organisms. However when we speak of an environment such as that which supports a riparian ecosystem we are of necessity referring to the array of influences on a particular organism or group of organisms. Thus our interest in the environment, although it may have been triggered by objective scientific curiosity, is for our purposes, constrained by the light that it casts on our ability to manage the forces that act upon our influence the biota in that environment.

This brings us to the concept of management. Here I would like to quote from the report of the Hudson Basin Project, a major Rockefeller Foundation supported study on the subject of environmental management which I directed "...management, ... can be defined as the activity - more or less skillful - of controlling or handling something. As a species man is unique to the degree in which he is able to manage his environment. Most environmental management is collective in the sense that it is governed by institutions. In our society we tend to think of institutions in terms of formal organizations, but the term can refer to any well established social arrangement or practice, even if it is not formally embodied in law or in a particular organization.

"...Are institutions part of the environment? Certainly as much or more than the physical environment, they are among the things that act on or influence man. So, too, are the values and attitudes embodied in institutions since these shape our perceptions of the environment in relationship to ourselves. Thus, the environment, any environment, is a dynamically and infinitely complex network of interacting influences both physical and non-physical. Issues that are generally regarded as "environmental" may revolve around questions of economics, ethics, or social policy, as well as around validity of scientific data or concepts about the physical world. Nevertheless, whatever the focus of conflict, environmental issues ultimately tend to involve rights or interests in physical things" (Richardson and Tauber, 1979).

I included the above quote in its entirety because it sets forth in succinct form the philosophical context within which the balance of this discussion will take place. Now let's look at management in more concrete terms. Essentially environmental management is concerned with the processes whereby its capacity to help meet human needs and aspirations is maintained or enhanced. The term management, as used in this paper, consists of the discharge of two primary but interrelated functions. (1) Figuring out what needs to be done and how to do it and (2) doing it. The relationship of these functions to the activities that have to be undertaken to discharge these functions and the fields involved are presented in the following graphic.

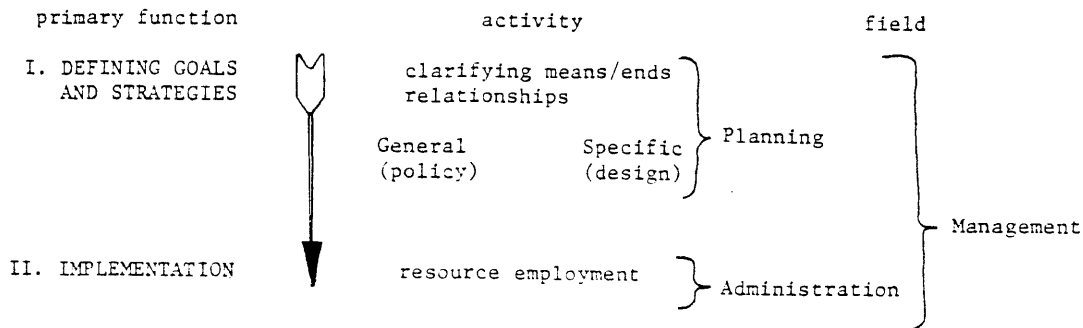

Figure 1.--Management defined

Management can also be understood in terms of the interrelationships of its components, which can be schematically illustrated as follows.

marching orders for administration. Administrative capacities in turn constrain what kind of policies can be adopted and what kind of designs can be executed. In any event, when these three

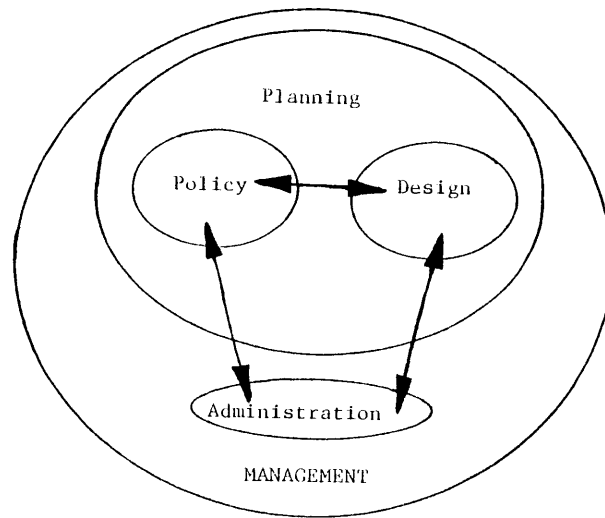
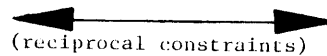

Figure 2.--Management-interrelationships of components



It can be readily seen that the first function, the definition of goals and the strategies required to implement them, is a planning activity. That is, it focuses on clarifying the relationship between means and ends. When means-ends relationships are articulated in general terms we refer to them as policies. By definition, policies are a settled course of action to achieve agreed upon objectives. When we express means-ends relationships in specific and concrete terms we refer to this as design, which is a means of stating in specific, concrete and measurable terms the things that need to be done and the means that are to be employed in doing them.

As noted in figure 2, these elements are interrelated by reciprocal constraints. Policy provides the agenda for design but design in turn tests the implications of policy. Design and policy are simply different species of the same genera of mental activity, namely the specification of the relationships between what needs to be done and how one is to do it. When these two definable activities are linked in an integrated fashion, we are planning. The decisions emerging from the planning effort essentially clarify what is to be done, how it is to be done and, of critical importance, what resources are to be allocated to achieve purposes agreed upon.

Implementation, the second major function of management, is carried out through administration which is defined as the employment and expenditure of resources to achieve and execute defined goals and strategies. Note the reciprocal relationships of these three interdependent components. Policy and design provide the basic

basic activities, policy, design and administration are linked in reciprocally interdependent ways and are discharged in a coordinated fashion, we can say we are managing effectively. That is, we are "controlling or handling something". Under this rubric management is the enveloping concept. It's easier said than done.

#### CRITIQUE

In the light of the concepts discussed above, what critique can be made of our riparian ecosystem management efforts? What conditions are suggested by such a critique which, if brought into play, would enhance our ability to strengthen institutional capacity for IRRM? First, the Cartesian reductionist empiricism which constrains modern science has resulted in most of our knowledge generation efforts being focused on the differentiation of the constituent components of the environment. As the result, comparatively little effort has been put on the integration questions which must be addressed if the environment as an interdependent whole is to be adequately defined and understood as a basis for its management. Now, it can be argued that this state of affairs is understandable and is in fact as it should be at this point in history, in as much as it is necessary to first think "vertically" (that is, in depth) about the constituent components of a complex system before one can think laterally and synthetically about the interrelationships of such components.

However, one cannot describe and explain and understand and manage the whole simply by understanding the properties of the elements which make up that whole. Humpty-Dumpty has been pushed off the wall. Much has been learned about how he works by the meticulous examination and quantification of his fragments. However, it is now past time for all the King's horses and all the King's men to try once more to put poor Humpty together again. The intellectual discipline which is required to do this is integration, that is, "to make whole". It's not a novel idea, really, the field of mathematics coordinates the use of both integration and differentiation as a means of understanding the properties of numbers. We must now learn to use these two thought processes in a more coordinated reciprocally interactive fashion on subjects that do not necessarily succumb to precise empirical measurement and quantification. These essential ideas are illustrated schematically by the following graphic.

Back in the 70's over one hundred and twenty of the best scientific and public policy brains in the country spent three years and three quarters of a million of the Rockefeller Foundation's money examining the interrelationships of the principal environmental issues confronting the 22,000 square mile Hudson River Basin. The bottom line was that they concluded that these individual environmental issues could not in fact be effectively managed because we lacked the fundamental institutional capacity to deal with the interrelationships and interdependencies with other elements in the environment (Richardson, Tauber).

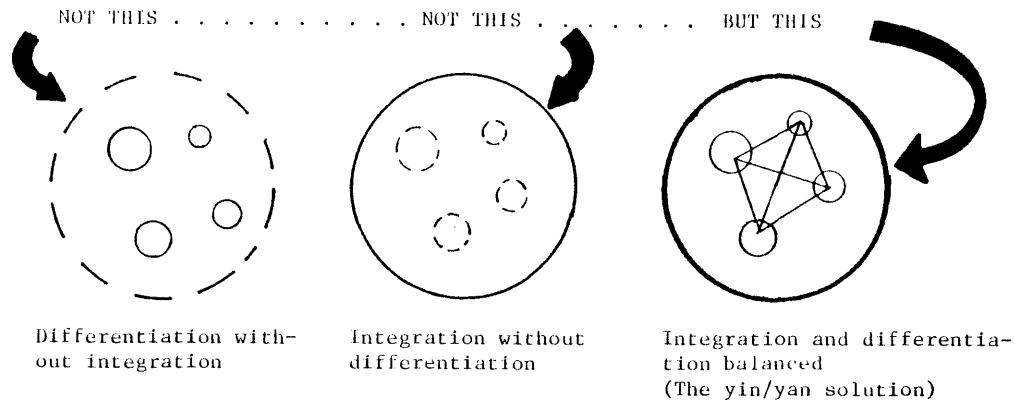

Figure 3.--Essential preconditions for effective environmental management

One does not have to look further than the current headlines for the evidence that validates this analysis. The pollution of the Kesterson National Wildlife Refuge by irrigation precipitated selenium in California provides a dramatic case in point. Few would argue that we did not have the scientific capability of predicting this environmental catastrophe or the technological means to avert it. If in fact knowledgeable people knew better, why was this egregious exercise in macro-environmental ecocide allowed to proceed? It's a complex subject, but it may not be an oversimplification to suggest that we know better than we do because of the fragmented institutional setting in which we make our decisions. Interests with conflicting values in competition for limited environmental resources are pitted in an adversarial process which does not reward compromise. Thus, our resource allocation processes do not have the capacity to effectively balance and resolve such conflicts.

The following matrix, taken from the report of the Hudson Basin project illustrates the degree of environmental interdependency and interaction of a single variable, (water resources) with the other components of the environment. Similar tables can be made for the other nine environmental variables studied. From such analysis one can gain an indication of the scope of the interactions with which integrated environmental management must deal.

On the subject of riparian lands management, Jon Kusler puts it this way "Many Federal, State and local programs now regulate, protect and manage riparian lands. However, these efforts are handicapped by limited geographical scope, narrow objectives, insufficient data and poor coordination" (Kusler).

What then might be considered the essential preconditions for strengthening institutional capacity for IRRM that are suggested by the preceding material? They can be summarized as follows.

POLICY AREAS									
WATER RESOURCES	Land use settlement	Transportation	Environmental systems	Energy systems	Land use/natural resources	Air resources	Biological communities	Health	Leisure
sub areas									
Municipal water supply	↻		↻					↻	↻
Industrial water supply	↻	↻	↻	↻					
Waste disposal	↻		↻	↻	↻	↻	↻	↻	↻
Power	↻		↻	↻		↻	↻	↻	
Irrigation	↻				↻		↻	↻	↻
Transportation		↻			↻		↻		↻
Recreation	↻	↻	↻	↻	↻	↻	↻	↻	↻
Biological systems	↻	↻	↻	↻	↻		↻	↻	↻
Aesthetics	↻	↻			↻		↻	↻	↻
Flood control	↻	↻	↻	↻	↻		↻	↻	↻

- ↻ Indicates Water Resources Sub Area significantly affects Policy Area.
- ↻ Indicates Policy Area significantly affects Water Resources Sub Area.
- ↻↻ Indicates reciprocal relationship.

Figure 4.--Interaction matrix

1. A knowledge base which clearly defines the characteristics and behavior of the resource to be managed as well as the dynamics of the external forces that are acting on the resource in ways which either enhance or diminish its utility.
2. The dissemination of such knowledge in terms which will influence public perception and will to act and thereby build constituencies of support for creating the institutional capacity required for integrated management efforts.

The Hudson Basin Project concluded that "Studies by the broad array of planning agencies serving the basin demonstrate that the area does not, in general, lack the technical capacity to address the myriad environmental management needs confronting it. What is lacking, in many cases, is the public understanding necessary to generate the political motivation and will to address such needs, and the institutional capacity to implement the plans and programs required."

#### STRATEGIES

What strategies which, if pursued over time, would work to achieve the prime objective of improved institutional capacity for IRRM? The Hudson Basin Project participants, (both the integrators and the discriminators) addressed this question for the environment as a whole. Although the conclusions developed are of specific relevance to that region, the process for strengthening environmental decision making which was designed has general application. The first step in the process is to define and articulate the principal environmental needs confronting the region. Ten basic needs were identified as being the most important on the basis of the criteria that these needs appeared to have the highest component of "unfinished business." That is to say there is a greater need for action in these areas compared to other areas where more progress has been made. As such it may be viewed as an initial statement of ten "planks" in a comprehensive "platform" for environmental management at the regional scale. Taken together they provide a good sense of the scope of concerns that such an effort would entail in that region.

Environmental needs in the Hudson Basin Region.

1. Rehabilitate inner city environment and control urban sprawl.
2. Reduce health hazards in the work and home environment.
3. Improve institutional capacity for regional water management.
4. Fill gaps in land use planning and regulation.
5. Moderate solid waste generation and improve disposal techniques.
6. Protect ecologically significant land and water resources.
7. Integrate the planning of transportation modes and land use.
8. Moderate energy demand and augment supply.
9. Strengthen interstate arrangements for air quality management.
10. Optimize public and private investment policies affecting the environment.

The Hudson Basin project concluded that the weakness of environmental decision making lies in the limited capacity of institutions to identify, assess, and manage the consequences of such decisions, and recommended five basic strategies which, if pursued over time, would work to correct such deficiencies.

Strategies for strengthening environmental management.

1. Improve information management.
2. Broaden assessment processes.

3. Increase and strengthen arenas for conflict resolution.
4. Improve the substance and explicitness of policy.
5. Strengthen institutional capacity to formulate and execute policy.

Note that each of these strategies serve as preconditions for the achievement of those which follow. For example, step 5 has been the focus of major efforts at the national, regional and local scale. However the limited success that has been achieved in this strategy area to date can be explained in part by the failures to implement preceding steps.

Simply defined, information management treats the acquisition of information, its organization for use, formatting for storage and retrieval and its communication to affected interests as elements of a continuous and coordinated process which is designed to achieve defined management objectives. Thus, to be effective, information management must have clearly defined goals and priorities. It is suggested that research on riparian resources might be most effective if organized under four basic headings:

1. Basic Inventories ("What do we have?").
2. Systems Dynamics ("How does it work, and how is it changing?").
3. Prediction ("How might it change in the future?").
4. Prescription ("What's needed, and how can we achieve it?").

The overall process proposed by the Hudson Basin project participants is outlined in Fig. 5 below. It is intended to have general relevance to the integrated management of large complex interdependent environments.

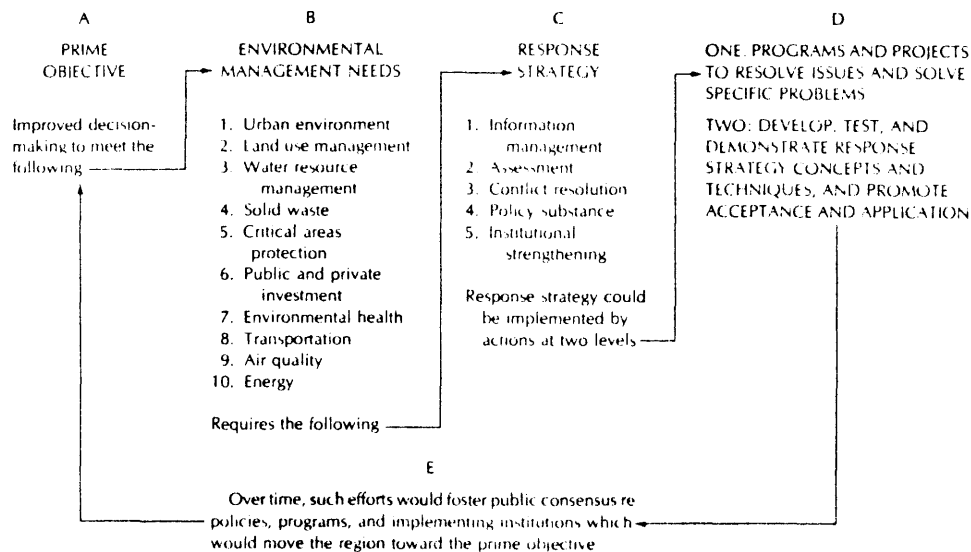

Figure 5.--Outline of a process to strengthen decision-making environmental management in the Hudson Basin region

At the more concrete level, there is a substantial array of environmental management strategies in place that have been designed to direct and control the timing, character and location of human settlement in ways which avert and mitigate man's impact on the natural environment. It would be fruitful to broaden the scope of riparian resource management to specifically consider the potential contribution of these growth management strategies in fostering the achievement of management objectives for various classifications of Riparian habitats. Fig. 6 below suggests a possible format and a general procedure for undertaking such an analysis. Further analysis might involve a broad cross-section of experienced riparian resource managers, land use planners and other policy experts in a form of delphi assessment of the general utility of a broader array of strategies that might be nominated. The choice of the appropriate "strategy mix" in relationship to the management objectives to be pursued in a specific situation is, of course, a matter of judgement that is constrained by the context of that situation. The intent of this suggestion is to move riparian habitat management toward a consideration of a more comprehensive array of management options that may be employed both on site and offsite by a variety of institutions working in the collaborative pursuit of common goals and objectives.

It should be noted that the problem which is the focus of this paper has received considerable attention in recent years. A number of innovative institutional approaches have been designed and put in place in a variety of settings. Such approaches improve society's capacity to guide public and private actions along

environmentally sensitive lines at a geographic scale that is large enough to encompass more of the interactions involved. Examples of such efforts include the New Jersey Pinelands Program, the Greenline Parks proposal of the American Land Resource Association, the Adirondack Park Agency, the Wild and Scenic Rivers Program and Coastal Zone Management. Such efforts can provide a better context for specific environmental management efforts such as riparian resource management. They offer an excellent array of prototypical approaches which deserve further development and application.

More innovation of this kind is clearly called for if the "state of harmony between man and the land" which Aldo Leopold has put forward as the true definition of conservation is to be achieved.

In conclusion it must be said that although the approaches to integrated environmental management outlined in this paper may be difficult to pursue, it is no exaggeration to suggest that our survival may well depend on our success. As Christopher Fry put it:

Thank God our time is now when wrong  
Comes up to face us everywhere,  
Never to leave us till we take  
The longest stride of soul men ever took  
Affairs are now soul size  
The enterprize  
Is exploration into God.  
Where are you making for? I takes  
So many thousand years to wake,  
But will you wake for pity's sake?<sup>3</sup>

Examples of Growth Management Strategies <sup>2</sup>	Riparian Habitat Type Classification <sup>1</sup>			
	Riparian	Hydroriparian	Mesoriparian	Xeroriparian
<ul style="list-style-type: none"> <li>*Public Acquisition               <ul style="list-style-type: none"> <li>-land banking</li> <li>-fee simple acquisition</li> </ul> </li> <li>*Public Improvements               <ul style="list-style-type: none"> <li>-location of facilities to influence growth</li> </ul> </li> <li>*Environmental Controls               <ul style="list-style-type: none"> <li>-critical areas</li> <li>-development of regional impact</li> <li>-pollution controls</li> </ul> </li> <li>*Development Rights Transfer</li> <li>*Restrictive Covenants               <ul style="list-style-type: none"> <li>-deed restrictions</li> <li>-easements</li> </ul> </li> <li>*Zoning</li> <li>*Subdivision Regulations</li> <li>*Tax and Fee Systems               <ul style="list-style-type: none"> <li>-preferential taxation</li> </ul> </li> <li>*Annexation</li> <li>*Capital Programming Process</li> <li>*Comprehensive Plan</li> <li>*Geographic Restraints</li> <li>*Moratoria</li> <li>*Environmental Impact Statement or Assessment</li> <li>*Cost/Benefit Analysis</li> <li>*Land Use Intensity Rating System</li> </ul>				
		Procedure: 1. List alternative management strategies. 2. List alternative management objectives. 3. Assign objectives potentially appropriate for each habit type. 4. Evaluate and rate potential effectiveness of each strategy in implementing each management objective in the context of the habitat types to which it is assigned. 5. Use product of Step 4 as a checklist in evaluating and selecting the mix of management strategies and objectives to be considered for a specific habitat.		

<sup>1</sup>(Johnson, Carothers, Simpson)  
<sup>2</sup>(Urban Land Institute)  
<sup>3</sup>(Anderson, et al.)

Figure 6.--Possible format for assessing potential effectiveness of alternative growth management strategies on riparian resource management.<sup>3</sup>

<sup>3</sup>Christopher Fry: A Sleep of Prisoners.

LITERATURE CITED

- Anderson, Larz T. and Conn, W. David, and Loeks, C. David and Randolph, John R. 1981. Growth Management for Blacksburg's Environmentally Sensitive Areas. Division of Environmental Systems, Virginia Polytechnic Institute and State University, 1981, Blacksburg, VA.
- Johnson, Roy E., Carothers, Steven W. and Simpson, James M. 1981. A Riparian Classification System. Proceedings: California Riparian Systems: A Conference on Their Ecology, Conservation and productive Management. University of California, Davis Sept. 17-19, 1981.
- Kusler, Jon A. 1978. A Challenge in Intergovernmental Cooperation. Proceedings of Symposium on Strategies for Protection and Management of Floodplain Wetlands and Other Riparian Ecosystems. Dec. 11-13, 1978 Callaway Gardens, GA.
- Office of Technology Assessment, U.S. Congress. 1984. Wetlands, Their Use and Regulation, OTA-0-26 March 1984, Washington, D.C.
- Richardson, Ralph W. Jr. and Tauber, Gilbert, (Editors). 1979. The Hudson Basin - Environmental Problems and Institutional Responses Volumes I, II, Report of the Hudson Basin Project Academic Press 1979 N.Y.



# American Fisheries Society Position Statement: Strategies for Riparian Area Management<sup>1</sup>

Gordon N. Haugen<sup>2</sup>

---

Abstract.--A draft of the American Fisheries Society Position Statement for the Management of Riparian Areas is presented.

---

## INTRODUCTION

The American Fisheries Society is actively involved in creating public awareness of the need for healthy riparian areas to sustain productive fishery resources. We have also worked with public agencies and private landowners to bring about improved riparian area management on State, Federal, Provincial, and private lands throughout the United States and Canada. In 1977, as a Society, we met with the Range and Wildlife Societies in Reno, Nevada, to discuss the management of riparian ecosystems and explore strategies for managing these areas to the benefit of fish and wildlife resources.

In 1978, the Western Division established a Riparian Committee which has published a riparian position paper, developed resolutions for Division and National meetings, sponsored symposia, published a best management practices paper, and is in the process of completing a slide tape program on western riparian areas, as well as a paper on the management of large organic debris. The Oregon Chapter was instrumental in shaping legislation in Oregon to give tax credits to private landowners who manage riparian areas to benefit fisheries and wildlife resources. This effort on behalf of the Oregon Chapter has encouraged the Idaho and Montana Chapters to initiate similar legislation. The Western Division has a continuous working relationship with land management agencies--particularly the Forest Service--to bring riparian area management to the forefront.

In 1979, the Western Division sponsored three symposia dealing with riparian area management at their meeting in Kalispell, Montana. Two were of a technical nature, while the third dealt with policy. The policy session brought together the leadership of the major land management agencies throughout the West to present their positions on riparian area management.

This involvement by Chapters and Divisions, has

succeeded in elevating the visibility of riparian area management to a position where there are enough policies written and executive orders passed at the Federal and State levels to bring about aggressive riparian area management to the benefit of dependent resources.

## ISSUE DEFINITION

This year, the American Fisheries Society's Environmental Concern Committee is developing a national policy statement on riparian area management. In our draft statement of policy, we defined riparian areas as geographically delineated areas with distinctive vegetative, fishery, and other resource values comprising both the aquatic and riparian ecosystems, and providing both the structural and nonstructural fisheries habitat components (i.e., streambank vegetation, channel structure, and water quality) required to sustain productive fishery resources.

## CONCERNS

Throughout North America, many streams no longer retain their once-productive characteristics; consequently, they now support reduced fish populations. More than a century of human use and development along streams has brought about many changes. Domestic livestock grazing within riparian areas and its resulting impacts on fisheries habitat throughout North America is well-documented in the literature. Livestock grazing is one of the multiple uses of the riparian area rangelands; however, years of improper grazing is one of the major reasons why so much of North America's public and private riparian area rangelands are in poor condition. Other resources that impact fisheries habitat in riparian areas are timber harvest, mineral and oil exploration, agriculture, urban development, and road construction. The Western Division of the American Fisheries Society addressed these uses in their 1981 and 1984 position publications. If these competing uses are allowed to continue within riparian areas without sufficient management constraints to protect the integrity of riparian habitat, adverse impacts will continue to occur on North America's fisheries resource. Research has shown that degraded riparian area fisheries habitat can be re-established, but social, political, and economic considerations often do not allow this course of action. Today's land and fisheries managers must not only manage existing resources properly, but also must correct past mistakes.

---

<sup>1</sup>Paper presented at the First North American Riparian Conference: Riparian Ecosystems and their Management. -- Reconciling Conflicting Uses, April 16-18, 1985, Tucson, AZ.

<sup>2</sup>Gordon Haugen, Tualatin, OR, is a Past President of the Western Division, American Fisheries Society.

## COURSE OF ACTION

### A. Policy

It is the policy of the American Fisheries Society (AFS) to aggressively foster an increased awareness of riparian area fisheries habitat values and management by State, Federal, Provincial, and local agencies. The AFS supports close coordination and cooperation among these agencies in managing and improving riparian areas on State, Federal, Provincial, and private lands in North America. The AFS strongly urges that all land management agencies declare as a matter of policy that riparian areas be recognized as distinctive habitat, and that they be declared areas of critical environmental concern. The AFS also urges that riparian areas be managed with state-of-the-art management practices, and that management prescriptions be vigorously enforced to protect fisheries and other resource values for the benefit of all users.

Since adequate streamflow is essential to the vegetative communities within the riparian area, the AFS strongly urges that State, Federal, and Provincial agencies legally recognize instream flows as a beneficial public use so that riparian areas can be maintained and protected. These agencies should identify and quantify riparian area resources and instream flows in the development of land and water management plans. The AFS encourages ongoing and future research and management on riparian area habitats relative to livestock grazing, mining, energy exploration and development, water storage, irrigation use, timber harvest, road construction, and other land uses that may affect riparian areas. Scientific studies and inventories can provide the basis for restoration, maintenance, and protection of riparian area fish habitats. Therefore, the AFS strongly recommends that all land managers actively work to determine and implement state-of-the-art management practices for riparian areas.

### B. Action Plan

The AFS will achieve this policy by working with all riparian area users and managers to improve riparian area management. This will, in turn, provide the riparian area fisheries habitat components (i.e., streambank vegetation, channel structure, and water quality) required to maintain self-sustaining productive populations of fish for recreational and commercial users. The following actions will be taken by the AFS to increase the awareness of fisheries habitat management required within riparian areas:

1. Foster cooperative relationships among land management agencies and private landowners responsible for riparian area management throughout North America.

2. Cooperate with public and private land managers in the planning and management of riparian areas to meet State, Federal, and Provincial land management agency mandates.
3. Request that riparian areas receive special consideration as distinct habitats in the planning and management of State, Federal, and Provincial lands.
4. Request that land managers develop best management practices for managing riparian areas, and update these practices as new research and management information becomes available.
5. Work for improved legislative and Congressional appropriations for restoration and rehabilitation of riparian areas on public and private lands.
6. Work towards obtaining a better balance of expertise for assignment to land management advisory boards.
7. Emphasize coordination with the Bureau of Land Management, and State and Provincial divisions that are responsible for the management of riparian areas. Continue to work with the Forest Service to encourage that their riparian area policies and management prescriptions are adhered to.
8. Work towards amending the Federal Land Management Policy Act and the National Forest Management Act to include additional direction on riparian area administration if the present management direction and policies are determined inadequate by Divisions and Chapters in addressing progressive riparian area management.
9. Continue Division and Chapter involvement in achieving State riparian tax incentive legislation.
10. Insist that riparian area management prescriptions are adhered to by State, Federal, and Provincial land management agencies and that they be monitored for effectiveness.

The AFS is dedicated to address these action items to insure that the integrity of riparian areas is maintained in order to enhance and perpetuate the quality and quantity of fisheries resources across North America.

# Riparian Zone Protection by TVA: An Overview of Policies and Programs<sup>1</sup>

Roosevelt T. Allen<sup>2</sup> and Ronald J. Field<sup>3</sup>

---

Abstract.--The Tennessee Valley Authority, since its inception, has promoted the protection and management of the riparian resources of the Tennessee River drainage basin. Current policies, practices, and major programs providing for protection of the riparian environment are described.

---

## INTRODUCTION

As a regionally based Federal natural resources development and conservation agency, the Tennessee Valley Authority, since its inception in 1933, has had a profound influence on the riparian environment of the Tennessee River drainage basin. The impacts of its dam construction activities on the riparian ecosystem of the Tennessee Valley as well as the general ecological effects of stream alteration on the riparian environment are well known. Lesser known is TVA's role in protecting riparian ecosystems.

Protection of the riparian environment is not new for TVA. Under the TVA Act of 1933, the Tennessee Valley Authority has the unique responsibility for fostering on a regional basis the physical, social, and economic development by providing flood control, improving navigation, generating electricity, and by furthering the proper use, conservation, and development of the natural resources of the Tennessee River drainage basin. Although its better known role in power production, navigation, and flood control often overshadows its conservation and natural resources activities, TVA, throughout its history, has had programs designed to either expressly or indirectly protect the riparian ecosystem of the Tennessee River drainage basin. For example, earlier conservation efforts by TVA, such as planting trees and ground covers on more than 350,000 acres, not only complemented TVA's water resources development projects, but the reforestation program not only increases the acreage of riparian forests but by curbing erosions and restoring the Valley's forest also reduced the loss of riparian habitat.

Today, TVA's integrated water control system of 40 dams and reservoirs (36 TVA dams) and with over 8 percent of the total stream miles impounded, the unified development of the Tennessee Valley called for in the TVA Act is virtually completed. Protection of riparian areas created by these projects is an integral part of TVA's mission. For the purpose of this paper the riparian areas include those areas, typically floodplain forests and wetlands, lying adjacent to impounded and free-flowing bodies of water and which are affected by the water body (Darnell, et al., 1976). Riparian zone protection is accomplished through a variety of programs and policies with some overlap between them. These may be classified as (1) land management and administration of Section 26a of the TVA Act; (2) floodplain management; (3) implementation of Federal environmental protection laws, regulations, and Executive Orders; and (4) natural resources development and conservation programs.

## LAND MANAGEMENT AND ADMINISTRATION OF SECTION 26a OF THE TVA ACT

TVA holds title to or interest in 654,000 acres (264,777 ha) of impounded surface, 346,000 acres (140,081 ha) of land and 11,280 miles (18,194 km) of lacustrine and riverine shorelines. In addition, under Section 26a of the TVA Act, TVA approval must be obtained for the construction, operation, or maintenance of any dam, appurtenant works, or other obstruction structure affecting navigation, flood control, or public lands or reservations across, along, or in the Tennessee River or any of its tributaries. TVA has also retained or acquired certain landrights along the shorelines of its reservoirs and use, release, or sale of these rights is frequently needed before shoreline development can proceed.

---

<sup>1</sup>Paper presented at the 1st North American Riparian Conference on Riparian Ecosystems and Their Management-Reconciling Conflicting Uses.

<sup>2</sup>Coordinator (Environmental Matters), Division of Land and Economic Resources, TVA, Knoxville, TN.

<sup>3</sup>Program Manager, Wildlife Resources Program, Division of Land and Economic Resources, TVA, Norris, TN.

TVA makes its reservoir property available for use by others through permits, licenses, sell, conveyance of transfers when it determines that such action will contribute to the achievement of TVA program objectives, or otherwise further the public interest and will not be adverse to the interest of the United States. TVA annually reviews and approves over 1,500 26a requests which may affect riparian habitat. These include boat docks or piers, boat launching ramps, marine rail-ways, driveways, shoreline protection structures, ports, barge facilities, highway and railroad embankment, and commercial recreational facilities. It also reviews and approves about 200 land use requests, ranging from a license for public recrea-tion purposes to the sale of fee title for an industrial park. These types of shoreland uses, for the most part, have little or no effect on riparian habitat. Certain of the uses, however, such as agriculture, barge terminal facilities, and commercial recreation can reduce productivity or severely alter the natural value of riparian lands.

In evaluating projects affecting its shorelands, TVA seeks to further multiple use of its land while minimizing adverse environmental impacts. While TVA's decision to deny or approve a request is not based solely on impact to riparian habitats, its evaluation procedures has direct implication on such areas. Project evaluation is accomplished by:

1. Multidisciplinary review: each request is reviewed by TVA specialists for potential environmental and program impact on current and proposed recreation areas, sensitive or natural areas, wild and scenic rivers or inventoried rivers (Department of Interior, 1980); wetlands; important wetlands and upland wildlife species and habitats; endangered or threatened species populations and their critical habitats; natural landmarks and other sensitive biological features of State and local interests; aquatic resources; air and water quality; flood control; navigation, and archaeological resources. Depending on the nature of the proposal and the kind and magnitude of environmental or program impacts, an environ-mental assessment of environmental impact state-ment may be prepared. The usual product of these reviews, however, is a project summary containing staff findings and appropriate environmental commitments to protect sensitive resources.

In addition to conducting its own evaluation of construction activities in or along the Tennessee River System, TVA and the Corps of Engineers (Corps) for several years have jointly processed permits for activities requiring authorization by both agencies. This cooperative relationship arises from the overlapping regulatory authority of Section 26a of the TVA Act and those of the Corps under Section 10 of the River and Harbor Act of 1899 and Section 404 of the Clean Water Act.

2. Design criteria and operational standards for private water use facilities: construction of private recreational water use facilities on the marginal strip lands,<sup>4</sup> and flowage easement areas<sup>5</sup> must conform to TVA standards and

guidelines. Under recently revised instructions, "the marginal strip may not be used in a way that will block or unduly restrict the general public's use of reservoir shorelands or water and all permissive uses are subject to environmental review and the paramount rights on behalf of the public." Furtherance of that objective is also accomplished by requiring all water-use facilities to be clustered and by stipulating that best management practices be used to control erosion and sedimenta-tion from areas disturbed during the construction of such facilities.

3. Reservoir land-use plans: historically, the shore-lands around TVA's reservoirs have been used to meet a range of regional and local resource deve-lopment needs and to enhance and improve the quality of life in the Valley (TVA, 1981). These TVA-owned shorelands along with adjoining private land have been utilized for the development of State parks, industry, wildlife management, and recreation. For the most part, these uses were in harmony with the environment, but sometimes in conflict.

In 1980, TVA began a new reservoir planning initiative for lands under TVA's control on its 9 major reservoirs. This planning process reflects its multiple use programs and land management responsibilities. Comprehensive reservoir-by-reservoir plans are developed based on information obtained from the public and extensive resource data, such as soil character-istics, location of current developments, forest cover, wetlands, and land use capability. The resulting land use plan is a decisionmaking guide that helps TVA to expedite the handling of land use requests and to better meet its responsi-bilities as a public land management agency. As of today, plans for three reservoirs have been completed and a fourth is under way. Through this process over 97,000 acres of TVA lands have been allocated for specific uses, including wildlife management and wetlands protection.

4. Anti-pollution covenants: certain standard provisions in TVA-issued licenses, leases, easements, and deeds limit or control potential impacts on the riparian zone. For example, TVA incorporates requirements for nonpoint source control measures in its land use agreements and the construction plans approved under 26a.

TVA also has accepted responsibility from the Governor of Tennessee under Section 208 of the Clean Water Act to control nonpoint sources from properties

<sup>4</sup>Shoreline margin of the reservoir situated between abutting private residential property and the waters of TVA reservoirs.

<sup>5</sup>Refers to the lake bottom and/or part of the shoreline margin of a reservoir that is in private ownership, but subject to certain rights acquired by TVA, generally including the right to flood and the right to remove obstructions.

under TVA control in Tennessee. Under this program TVA has developed guidelines for using best management practices (BMP's) in forest harvesting; for control of erosion and sedimentation from land disturbing activities as part of land use easements; and for agricultural activities on TVA lands.

#### FLOODPLAIN MANAGEMENT

Development in the floodplains has resulted in significant losses of riparian ecosystems and their values to wildlife (Brinson et al., 1981). While these losses in the southeastern United States are largely attributable to clearing of bottom land hardwoods and floodplain forests for agriculture uses, urban uses of riparian lands also has contributed to the decline. These latter uses were the impetus behind the development of TVA's floodplain management program. Beginning in 1953, TVA launched a program to "keep people away from floods." This program has four major components: provision of general and detailed information on flooding, technical assistance to local planners and officials, assistance in developing local comprehensive flood damage reduction plans, and limited assistance in implementing portions of these plans where it is felt to be in the public interest (TVA 1983). By working with local communities and local and State planners, TVA has assisted more than 300 communities and over 100 communities have officially adopted floodplain regulations. These efforts on the part of TVA and the many communities have not only reduced flood loss, but limited the loss of and impact on riparian habitats.

#### IMPLEMENTATION OF FEDERAL ENVIRONMENTAL PROTECTION LAWS

As a Federal agency, TVA is required by the National Environmental Policy Act (NEPA), Public Law No. 91-190 (1970), as amended, to incorporate environmental consideration into its decisionmaking. In carrying out this mandate, TVA has developed counterpart regulations which emphasizes an interdisciplinary approach to evaluation of projects that could potentially affect the quality of the human environment. This ensures not only that TVA projects are evaluated for their environmental impact but that projects of others involving TVA action (e.g., 26a approvals, technical or financial assistance, landrights) are also appropriately evaluated. While compliance with NEPA per se does not prohibit or otherwise control TVA's activities which affect riparian habitats, the interdisciplinary review process, coupled with its resource conservation responsibilities, ensures that loss or degradation of riparian habitat is minimized to the extent feasible.

TVA also has developed procedures implementing Executive Order Nos. 11988, Floodplain Management, and 11990, Protection of Wetlands. Consistent with the Executive Orders, TVA makes every effort to avoid long- and short-term impacts associated with the occupancy and modification of floodplains and with the destruction of wetlands. TVA applies this commitment not only to its own activities but

also to direct or indirect support of individual projects or programs as appropriate. One example of the effectiveness of TVA's wetlands protection program is the construction and maintenance of transmission lines. Under current guidelines, clearing of streamside vegetation is discouraged and when clearing becomes necessary only hand equipment is used in order to limit impacts on riparian habitat.

#### DEVELOPMENT AND CONSERVATION OF NATURAL RESOURCES

Because of the importance of riparian lands to wildlife and fish, TVA has always had programs to protect and enhance these resources. One of these programs is addressed more completely in another paper at this symposium by Field and Allen.<sup>6</sup> In addition to these programs, TVA initiated in 1976 the natural heritage project as a means of furthering its resource conservation efforts. This program identifies opportunities to protect and enhance unique or endangered species, unusual or critical ecosystems, and areas having other natural or scenic significance on TVA lands and other lands throughout the Tennessee Valley. This cooperative effort among TVA and public and private organizations has resulted in the identification of 33 significant natural or scenic sites encompassing over 6,500 acres. While these sites are not located entirely in riparian zones, many of them contain some elements of riparian habitats.

Two such areas are Raccoon Creek and North Sauty Waterfowl Refuge. The former area is a cove at Tennessee River Mile 396 which serves as flyway for a bachelor colony of the federally endangered gray bats (Myotis grisescens) that roost in a nearby cave. This area also provides habitat for several plant species, Shoenolirion cragewn (sunnybells) and Ribes curvatum (gooseberry) of special concern in Alabama. The second area, North Sauty Creek, which is located in Jackson County, Alabama, has 1,590 acres of floodplain forest, of which 1,260 acres are classified as wetlands.

In addition to the aforementioned policies and programs, TVA recently adopted a stream modification policy which would have far reaching effects on streams and their associated wetlands. The focus of this policy is stream alteration activities; ie., channelization, structural modification, and renovation, which are known to cause substantial disruption of streamside ecosystems (Brinson et al., 1981). This policy provides in part:

The preservation of these ecosystems and a halt to the continual diminishment of total natural stream values in the Valley and the Nation are important to ensuring a healthful and productive human environment. Therefore, it is TVA policy to avoid further channelization or environmentally degrading structural modification or renovation of applicable water within the Valley or other regions subject to TVA actions except where both significant public benefits are clearly established and environmental damage can be avoided or substantially mitigated.

An example of this policy and TVA's commitment to nonstructural flood control measures is its participation in a project with eight counties in west Tennessee, known as the West Eight County Area Stream Channel Restoration Program (TVA, 1982). Briefly, the program consists of selective removal of silt, sand, gravel plugs, log jams, snags, drift accumulations, beaver dams, brush, downed trees, and other debris from within the channel along certain stream reaches to facilitate natural stream-flow. Since the stream problems are due in part to upland erosions and poor land-use practices, an erosion control program also was initiated. The West Eight Program demonstrates that stream blockage problems can be corrected without sacrificing the beneficial values of riparian habitats.

In conclusion, the TVA Act of 1933, Agency's policies and programs, along with recent environmental legislation provides the basic framework for protection and management of the riparian ecosystem of the Tennessee Valley. Although TVA, as well as others, will continue by necessity to develop within the riparian zone, current policies and practices of the Agency such as land use plans and floodplain management, provide the means to safeguard the riparian ecosystem from significant diminishment of important riparian values.

---

<sup>6</sup>R. J. Field and R. T. Allen. 1985. "Tennessee Valley Authority's Management of Riparian Zones to Benefit Wildlife," presented at the North American Riparian Conference on Riparian Ecosystems and Their Management-Reconciling Conflicting Uses in April 1985.

#### LITERATURE CITED

- Brinson, M. M., B. L. Swift, R. C. Plantico, and J. S. Barclay, 1981. Riparian Ecosystems: Their Ecology and Status. U.S. Fish and Wildlife Service (FWS) BX 5-81/17. Washington, D.C. 154 pp.
- Darnell, R. M., W. E. Pequegnat, B. M. James, F. J. Benson and R. A. Defenbaugh, 1976. Impacts of Construction Activities in Wetlands of the United States. U.S. Environmental Protection Agency, Ecological Research Series, EPA-600/3-76-045, 393 pp.
- Tennessee Valley Authority, 1981. Stream Renovation Program - West Eight County Association of Soil Conservation Districts. Environmental Assessment. 31 pp.
- Tennessee Valley Authority, 1981. Pickwick Reservoir Plan, Volume I, Office of Natural Resources, Knoxville, Tennessee. 57 pp.
- Tennessee Valley Authority, 1983. Floodplain Management: The TVA Experience. Floodplain Management Branch, Office of Economic and Community Development, Knoxville, Tennessee.
- U.S. Department of the Interior, 1980. The River Inventory of the Southeastern United States. Heritage Conservation and Recreation Services, Atlanta, GA. 37 pp.

# Position Paper: Activities and Views of the U.S. Fish and Wildlife Service on Riparian Ecosystems<sup>1</sup>

Michael J. Spear<sup>2</sup>

---

Abstract.--Riparian habitat is vital to the Nation's fish and wildlife resources. Presently, many activities are adversely impacting this important ecosystem. Programs of the U.S. Fish and Wildlife Service that provide protection for riparian zones are discussed. Numerous examples of what is being done to conserve riparian areas are highlighted.

---

## INTRODUCTION

This U.S. Fish and Wildlife Service position paper is an update of the report that was delivered in 1978 at the riparian symposium at Calloway Gardens, Georgia. Since that time, considerable progress has been made in the conservation of this much abused habitat. Despite this progress, there is still much more to be done. We are working on this problem as diligently as our budget and manpower resources allow and continue to treat this important resource as one of our highest priorities. Conferences such as this highlight the fact that riparian areas are a major concern of people nationwide and reinforce the fact that we in the Service are correct in keeping this issue in the forefront of our interest. This sense of the value of riparian habitat is universal among Service biologists regardless of area of expertise or program discipline. Every opportunity is taken to proclaim the value of this habitat, point out threats to its continued existence, and, where practicable, take official action to protect and enhance this valuable resource.

I want to relate a story to you that shows how far we've come in public awareness of riparian issues in the last few years. Recently, a couple of our biologists were doing some field checking of wetlands in southwest New Mexico. They requested trespass rights from a private landowner, showing him on a USGS quadrangle where they wanted to go on his ranch. He described the area as, quote, "That's a riparian area that I keep fenced off from my cattle." When you can find a rancher in an isolated area of New Mexico describing an area as riparian, then we know we are getting this issue some public attention.

As most of you know, riparian ecosystems support some of the most productive and diverse wildlife populations in the United States. However, they are being lost at an alarming rate because of land use changes and water resource development projects. Because of man's attraction to water, whether it be for agricultural or urban development, land use has and will continue to change at the expense of riparian habitat. There are numerous programs that the Service is involved in that are combating this trend, with some notable success.

## CURRENT ACTIVITIES OF THE FISH AND WILDLIFE SERVICE

The Service's role in riparian protection involves three main lines of activity: participation in the environmental planning and regulatory process; direction of research, baseline studies, and inventories; and, where necessary, land acquisition. Fish and Wildlife Service involvement in riparian protection originally stemmed from the agency's responsibilities for protection and management of migratory birds, particularly waterfowl. However, as both public environmental awareness and the Service's own responsibilities have broadened, its programs have reflected concern for the full range of environmental values inherent in protecting riparian ecosystems.

## Participation in Environmental Planning and Regulation

Land acquisition is the most effective process for protection of riparian areas, but even under the most favorable conditions only a minimal amount of land can ever be bought. Other means must be used which leads us to the Service's participation in the environmental planning and regulatory process. The Fish and Wildlife Coordination Act is the primary authority used for our role in environmental planning and the regulatory process. Under the authority of this Act, the Service evaluates the impact of federally funded, permitted, or licensed

---

<sup>1</sup>Paper presented at the Interagency North American Riparian Conference, Riparian Ecosystems and Their Management: Reconciling Conflicting Uses, Tucson, Arizona, April 16-18, 1985.

<sup>2</sup>Michael J. Spear is Regional Director, U.S. Fish and Wildlife Service, Southwest Region, Albuquerque, N.M.

water resource development projects and recommends measures for the mitigation and/or enhancement of fish and wildlife resources in conjunction with proposed projects. This Act allows us to comment and advise on projects that run the gamut from large federally funded projects, such as dams, to small private projects, such as a pier. Even though we have no veto or enforcement power other than on Service-administered lands, our comments are usually taken seriously by the responsible federal agency and, through this medium, riparian areas sometimes can be conserved.

Major gains in such conservation have been achieved through coordinated planning as directed by the Fish and Wildlife Coordination Act for the Regulatory Storage Division of the Bureau of Reclamation's Central Arizona Project. Under the authority of that Act, and in concert with the State of Arizona, the Service developed several mitigation recommendations for approximately 42,000 acres of fish and wildlife habitat impacted by the proposed dam construction or modification on the Salt, Verde, and Agua Fria Rivers. Riparian habitat constituted only a small percentage of actual acres affected, but was recognized as the most valuable of habitats within the project area. As such, it received the highest priority in the planning process. Through the implementation of the Fish and Wildlife Service's Mitigation Policy, we designated areas of riparian habitat which could not be impacted in any way - their value to endangered species and overall ecosystem stability was found to be too high to allow any modification. Remaining riparian areas within the affected river basins were ranked only slightly lower in quality, but were still deemed crucial elements of the terrestrial and aquatic communities. Impacts to those areas required full and in-kind mitigation. For every unit value lost, an equal unit should be replaced. This level of complete mitigation was accepted by the Bureau of Reclamation and included in final project design.

The Central Arizona Project represents only one example of protection of riparian resource values for fish and wildlife through coordinated planning. However, as planners and builders continue to look to the nation's riparian areas for development, continued efforts at accommodation where possible, but protection where necessary, will become major components of this planning. Using the Fish and Wildlife Coordination Act and the Service's Mitigation Policy, we can provide responsible biological bases upon which the values of riparian habitat may be incorporated into project design.

With the advent of the National Environmental Policy Act, the Service now has an advisory role in a wide array of projects that may not directly impact on water resources. For instance, we might comment on a Department of Housing and Urban Development Environmental Impact Statement and suggest ways to lessen secondary impacts of a project on riparian habitat. Our advice would carry certain weight because of the Executive Orders on Protection of Wetlands and Floodplain Management. These Orders direct federal agencies to avoid impacts, either direct or indirect, on

wetlands and floodplains, whenever there is a practicable alternative.

#### Research, Baseline Studies, and Inventories

Our involvement in development of baseline (natural resource) information on riparian areas may be the most important contribution we make for the conservation of this habitat. I can almost hear you all thinking that what usually happens when we gather information on a riparian area is that we give a sum of money to someone to study the area and then the area is developed as if the study didn't exist. In other words, the study may have informed us that there were animals or resource values in a particular area, but we did not have the clout to influence project modifications. That is often the case, but let me give you an example of a study on a proposed U.S. Army Corps of Engineers project that did pay huge dividends. A number of years ago, the Corps came to us and requested information on what impacts their proposed project would have on a riparian area in the Middle Rio Grande. Our Ecological Services Field Office in Albuquerque, New Mexico, performed a preliminary study and delivered a Fish and Wildlife Coordination Act report to the Corps in which it stated, among other things, that more resource information was needed in order to adequately evaluate the problems. The Corps reacted to this report in the most positive way possible. They devoted large resources to the questions we asked and eventually requested assistance from other agencies. A study group was then formed which involved the Service, the Bureau of Reclamation, New Mexico Department of Game and Fish, U.S. Army Corps of Engineers, and the Soil Conservation Service. This study group, after detailed analysis, decided what further data were needed, and more importantly, finally settled on a contractor who could deliver the answers. The contractor performed admirably and was able to deliver data that were used by managers to determine the impacts of the project. For instance, the contractor informed us that of 440 bird species in New Mexico, 62 percent or 277 species were in the study area. The contractor also informed us specifically as to what parts of the riparian habitat were most valuable. The project was then planned and modified by the Corps so that impacts to fish and wildlife resources were substantially lessened.

In another area of pre-development planning, the Service has recently initiated two special projects, one involving bottomland hardwood habitat in Oklahoma, the other riparian habitat in Arizona. In Oklahoma, we are working in 28 counties in the eastern part of the State to determine the status of bottomland hardwood habitat. Based on our recently completed study, we determined that 85 percent of this habitat has been converted to other land use. This study greatly assisted us in raising a red flag on this important, dwindling resource. We are now seriously studying certain tracts of this habitat for acquisition. Additionally, because of what we found in eastern Oklahoma, we are beginning a second study to determine the status of riparian habitat in western Oklahoma.



In Arizona, our Ecological Services Field Office in Phoenix is initiating a cooperative study to inventory riparian habitat in the State. Presently, they are conducting inquiries among other agencies to determine the interest and effort that can be devoted to this important task. Hopefully, a cooperative effort can be conducted that will give us much needed baseline data that we can use for planning.

#### Land Acquisition

As we stated in our 1978 position paper, the Fish and Wildlife Service had at that time about 35 million acres in National Wildlife Refuges and Waterfowl Production areas. The Refuge system now consists of about 90 million acres. Most of the new acreage is in Alaska. Interestingly, in the lower forty-eight states a large number of acres that we have recently purchased have been targeted in riparian areas. For example, the Tensas River National Wildlife Refuge in Louisiana, which is approximately 51,500 acres, is predominantly bottomland hardwood habitat. Panther Swamp National Wildlife Refuge, another recently purchased bottomland hardwood area located in Mississippi, encompasses approximately 20,000 acres. Additionally, the much publicized Atchafalaya River floodplain, which has become one of our most important national resource priorities, is slowly but surely being protected. The Service and the State of Louisiana presently control 50,000 acres with approximately another 10,000 acres proposed for purchase in the near future.

Moving a little closer to home, our Southwest Region (Texas, Oklahoma, Arizona, New Mexico) has been very active in plans for acquisition or protection of bottomland hardwood areas in Texas and Oklahoma. We have identified a number of areas in these two states for protection and hopefully will be able to afford some sort of security to these ecosystems in the near future.

In southeastern Arizona, the San Pedro River and its adjoining riparian habitat have long been identified as being a nationally significant ecosystem. This river is the best remaining example of a major riparian ecosystem in the Southwest still largely unaffected by man. This nationally significant river and its adjoining vegetation provides nesting, migratory, or wintering habitat for at least 20 raptor species and a total of ap-

proximately 210 species of birds. Additionally, a study recorded 78 species of mammals in the grasslands corridor between the riparian woodlands and adjacent mountains. This represents the second-highest mammalian diversity recorded in the world. Significantly, the San Pedro provides a critical link to many species that travel between Mexico and the United States. Unfortunately, this valley is being threatened by extensive clearing of the riparian areas for agricultural, residential, and recreational development. The State, with very active leadership from Governor Babbitt, is analyzing protection strategies for the San Pedro River. The Service is pleased to provide support information for Arizona's effort.

#### THE FUTURE FOR RIPARIAN HABITAT

Increased public awareness is critical to the conservation of our remaining habitat. We must keep public attention on this resource by taking every opportunity to speak out on the issues. This much abused habitat, especially in the West, demands our undivided attention. We must all keep in mind that in our democracy no action is usually taken until we have a concerned citizenry that demands action from its elected officials. A concerted effort by all of us is needed to keep this issue in the forefront of public awareness. Without this involvement, all the studies, symposia, and concern by resource agencies will be for naught. The whole issue of wetlands, which includes riparian habitat, is presently in the limelight and receiving considerable attention. It is incumbent upon all of us to guarantee that this attention continues to prevail, thus insuring the preservation of riparian habitat for future generations to enjoy.

"The last word in ignorance is the man who says of an animal or plant: 'what good is it?' If the land mechanism as a whole is good, then every part is good, whether we understand it or not. If the biota, in the course of aeons, has built something we like but do not understand, then who but a fool would discard seemingly useless parts? To keep every cog and wheel is the first precaution of intelligent tinkering."

Aldo Leopold--A Sand County Almanac

# The Effects of Large Storm Events on Basin-Range Riparian Stream Habitats<sup>1</sup>

William S. Platts, Karl A. Gebhardt, William L. Jackson<sup>2/</sup>

Abstract.--Large storm events had major impacts on stream riparian reaches that had received heavy livestock grazing. One ungrazed rehabilitated stream reach actually improved in habitat condition while the two adjacent grazed stream reaches decreased. Each stream reacted differently to channel erosion, with two streams showing mainly lateral channel movement and the third stream vertical channel movement.

## INTRODUCTION

This report describes habitat changes in three riparian stream systems from 1978 through 1984. This is a valuable period for analyzing environmental fluctuations because broad areas of the Great Basin experienced some of the lowest and highest stream flows on record.

## STUDY AREA

The study streams are in Nevada (Chimney and Cance Creeks) on the northern fringe of the Basin and Range physiographic province and in Utah (Big Creek) on the fringe of the middle Rocky Mountain physiographic province (fig. 1). Historically the watersheds of all three streams have been heavily grazed by livestock. Complete descriptions of study streams can be found in Platts and others (1983b), Platts and Nelson (1983), and Platts and Nelson<sup>3/</sup>.

Few flow data exist for Chimney Creek. However, based on a nearby stream record, peak flows in 1984 were in the range of a 500-year flow event (Siebert personal communication). U.S.

<sup>1/</sup>Paper presented at the North American Riparian Conference, Tucson, Arizona, April 16-18, 1985.  
<sup>2/</sup>William S. Platts is Research Fisheries Biologist, USDA Forest Service, Intermountain Forest and Range Experiment Station, Boise, Idaho. Karl A. Gebhardt is Hydrologist, Bureau of Land Management, Boise, Idaho. William L. Jackson is Hydrologist, Bureau of Land Management, Denver Service Center, Denver, Colorado.

<sup>3/</sup>Platts, W. S., and R. L. Nelson. In press. Stream habitat and fisheries response to livestock grazing and instream improvement structures: Big Creek, Utah. *Journal of Soil and Water Conservation*.

Geological Survey Records<sup>4/</sup> collected on Cance Creek show peak flows of 114 cfs on May 30, 1983, and 127 cfs on May 12, 1984. These flows are approximately 2 to 14 times larger than mean annual discharge peak flows for 1980, 1981, and 1982, which were 60, 9, and 50 cfs, respectively. Flows for Big Creek are not available, but on June 4, 1983, the Bear River that Big Creek empties into, exceeded all past 40-year flow records (Millard and others 1983) at 3630 cfs and was nearly as high in 1984 at 3050 cfs (Harenburg personal communication).

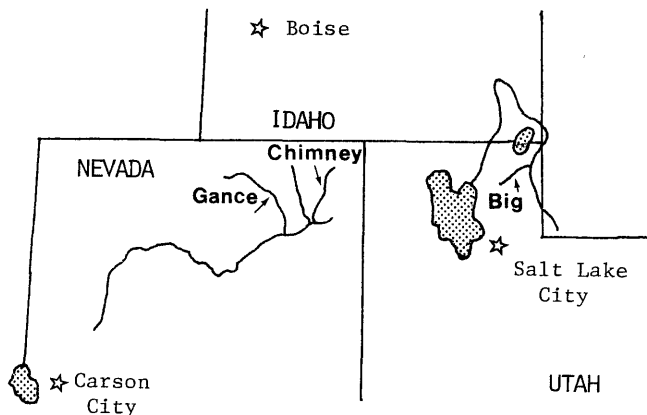

Figure 1.--Study site locations.

<sup>4/</sup>U.S. Geological Survey. 1984. Unpublished water level records. U.S. Geological Survey. Carson City, Nevada.

## METHODS

The basic study design was to randomly select 1,800 ft of stream and subdivide it into 181 transects placed at 10-ft intervals along the stream for location of all data collection. A complete description of the geomorphic, riparian, hydrologic, and fish population methods can be found in Platts and others (1983a), Platts and others (in preparation), and Ray and Megahan (1979).

## RESULTS

### Chimney Creek

Chimney Creek suffered severe floods in 1983 and 1984 that unraveled the streambanks and made many channel changes (figs. 2 and 3). Table 1 shows the reduction of vegetative overhang in 1984, the year of most severe flooding. In 1981 there was little vegetative overhang, but this was during periods of heavy grazing. In 1982 and 1983, vegetative overhang increased because of two successive years without grazing. Grazing was also minimal in 1984, but the heavy bank scouring still reduced the overhang. The flooding increased fine sediments in the channel, but the scouring flushed gravel downstream and replaced it with rubble. The fines probably re-deposited as flood flows receded. The increased substrate embeddedness rating (1 is high, 5 is low) in 1984 reflected the increase of fine sediments. Chimney Creek became wider and deeper (table 1) after the floods of 1983 and 1984, but pool quality and pool-riffle ratio were reduced.

In years past, the Chimney Creek streamside zone was heavily dominated by large aspen trees. Evidence of this aspen forest still exists in the large amount of decomposing aspen logs in the Chimney Creek channel. The aspen population drastically decreased, probably because of a combination of wind blow down, beaver cutting the large mature trees, and heavy cattle grazing

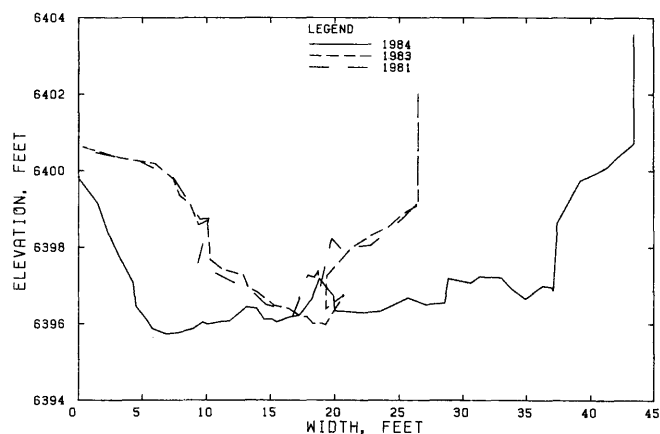
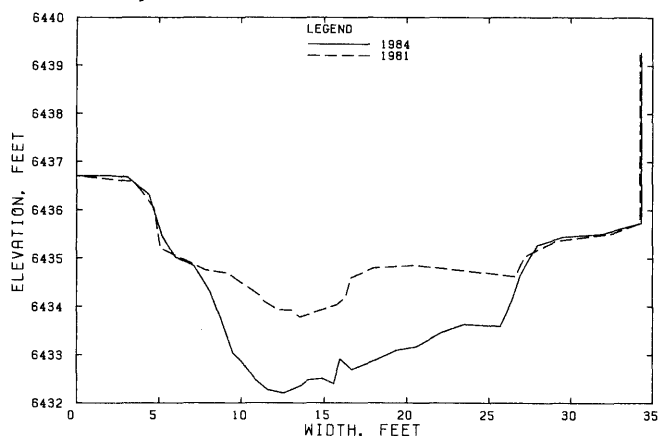

Figure 2.--Chimney Creek channel cross section 31, 1981-84.

Figure 3.--Chimney Creek channel cross section 146, 1981-84.



controlling the annual aspen sprouting and seedlings. The large aspen limbs and logs that held the Chimney Creek channel together decreased in volume and decomposed so that they no longer had the capacity to hold the acquired

Table 1.--Physical environmental means (plus or minus 95% confidence about the mean) for the Gance and Chimney study areas. Vegetative overhang, width, and depth in feet; fine sediments and gravel in percent; embeddedness and pool quality in units; and pool-riffle in ratio.

Variable	1978	1979	1980	1981	1982	1983	1984
<u>Gance</u>							
Vegetation overhang	0.10(.03)	0.13(.04)	0.12(.04)	0.11(.03)	0.30(.06)	0.15(.05)	0.06(.03)
Gravel	81 (4)	70 (3)	71 (4)	76 (3.8)	73 (3.6)	64 (3.6)	58 (4)
Width	5.2 (.3)	5.5 (.2)	6.3 (.3)	6.1 (.3)	6.0 (.3)	6.5 (.3)	7.4 (.3)
<u>Chimney</u>							
Vegetation overhang				0.06(.03)	0.16(.04)	0.11(.05)	0.05(.03)
Fine sediments				8.4 (-)	8.5 (-)	6.7 (-)	17.6 (-)
Gravel				57 (3.5)	48 (4.1)	40 (3.9)	18 (2.5)
Embeddedness				3.2 (.1)	2.7 (.1)	3.1 (.1)	1.7 (.1)
Width				4.7 (.3)	4.6 (.3)	5.5 (.3)	6.9 (.4)
Depth				0.15(.01)	0.17(0.02)	0.19(.01)	0.22(.02)
Pool quality				2.8 (.2)	3.1 (.02)	2.4 (.7)	1.8 (.2)
Pool-riffle ratio				2.7 (-)	2.7 (-)	1.7 (-)	1.0 (-)

Table 2.--Some examples of minimum channel elevations in feet and translocation distances<sup>1/</sup> in feet at four selected stream transects.

Stream	Year						
	1978	1979	1980	1981	1982	1983	1984
<b>Chimney</b>							
Elevation			18		4	35	
Translocation			6394.7		6394.7	6386.8	
Elevation			9		10	31	
Translocation			6395.9		6395.7	6388.3	
<b>Gance</b>							
Elevation	11.2		7.7	8.7	4.3		17.1
Translocation	6520.6		6521.2	6521.3	6521.3		6521.3
Elevation		14.5	13	12.5	10.3		9
Translocation		6505.7	6506.7	6506.2	6505.5		6504.4

<sup>1/</sup> Translocations are distances from the benchmark stake to the point of minimum channel elevation.

Table 3.--Fish biomass estimates in oz/ft<sup>2</sup> (x10<sup>-2</sup>) for Chimney, Gance, and Big Creeks.

Study Area	1978	1979	1980	1981	1982	1983	1984
<b>Chimney Creek, Nevada - Cutthroat trout</b>							
	-	-	-	0.4	0.6	1.1	0.8
<b>Gance Creek, Nevada - Cutthroat trout</b>							
	1.1	1.6	3.2	2.3	1.2	1.1	1.4
<b>Big Creek, Utah - Rainbow trout</b>							
Site 1	-	0.3	0.7	-	-	-	0.2
Site 2	-	0.4	0.3	-	-	-	0.1
Site 3	-	0.5	0.1	-	-	-	0.2

alluvium underlying the channel. Consequently, large floods were capable of scouring valley alluvium materials and causing accelerated erosion of the Chimney Creek streambanks and channel (table 2).

The Humboldt cutthroat trout (*Salmo clarki henshawi*) not only survived the floods, but actually had higher summer populations during the high water years of 1983 and 1984 than during the lower water years of 1981 and 1982 (table 3). Drought conditions, which caused Chimney Creek to flow ephemerally, may cause more severe limiting factors than floods. Now that the Chimney Creek channel is largely modified, it will be interesting to see how cutthroat trout summer in Chimney Creek during the next drought years.

#### Gance Creek

Gance Creek mainly showed vertical change resulting from the major flood events (table 2 and fig. 4). But some cross section profiles (fig. 5 and 6) showed some lateral change. Because of its large vegetative canopy cover and streambank vegetation biomass dominated by trees, the Gance Creek streambanks were more resistant to lateral movement. Had Gance Creek sustained its past control by beaver dams that occurred in the 1950's and 1960's, it would probably have suffered even less from the high flows. The only variables possibly affected by the high flows would have been reduced gravel in the channel (similar to what happened in Chimney Creek), increased stream width primarily because of the higher summer flows, and reduced vegetative overhang.

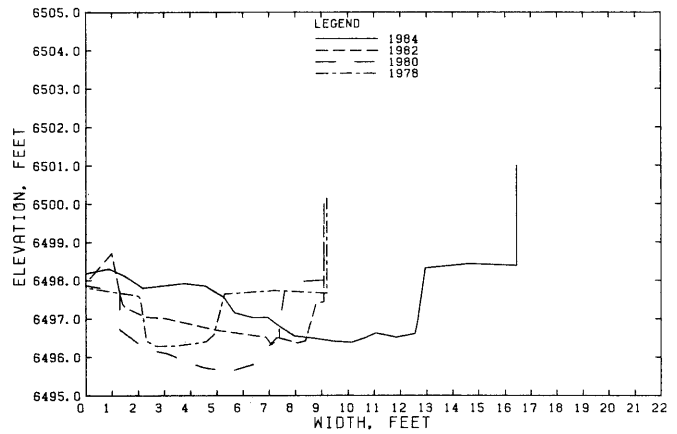

Figure 4.--Gance Creek channel cross section 43, 1978-84.

Figure 5.--Gance Creek channel cross section 89, 1979-84.

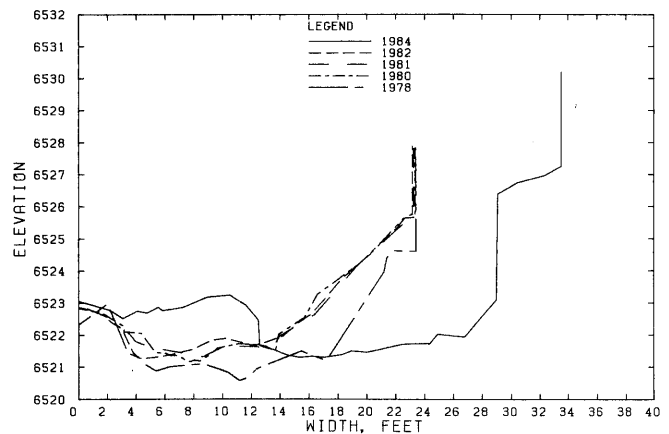
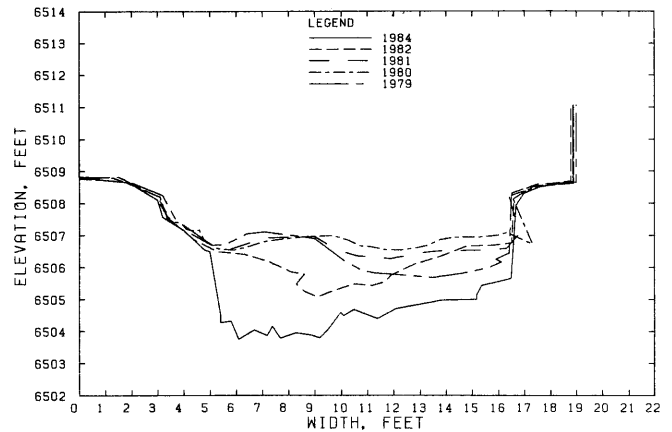

Figure 6.--Gance Creek channel cross section 147, 1978-84.

In Gance Creek the Humboldt cutthroat did best during the drier years of 1980 and 1981. However, the population during the flood years of 1983 and 1984 was quite similar to the lower flow years of 1978 and 1979. Gance Creek has better summer flows than Chimney Creek. Therefore, high flows could have more proportional effect on fish populations.

## Big Creek

The sites on Big Creek are described separately because site 2 has been rested (ungrazed) for a sufficient period (about 10 years) to induce dramatic rehabilitative changes. Stream width increased dramatically--by about 40 percent (table 4)--between 1982 and 1984 (1983 and 1984 were flood years) in the grazed reaches. The improved riparian-bank conditions in the ungrazed site 2 were able to contain the excess streamflow, and only a slight increase in width occurred. In the grazed upstream site 3, extensive lateral movement and redeposition of bedload sediments occurred, whereas in grazed site 1, immediately downstream from the ungrazed site 2, there was extensive bank side cutting but reduced deposition of sediments occurred. This combination may have occurred because large volumes of fine sediments were trapped in the rehabilitated riparian zone of the adjacent upstream ungrazed site.

Table 4.--Physical environmental means (plus or minus confidence interval around the mean) for Big Creek. Habitat type and pool quality in units, bank alteration and fine sediments in percent, stream width and streambank undercut in feet, and streambank angle in degrees.

Variable	1978	1979	1980	1982	1984
<u>Habitat type</u>					
Site 1		12.9(0.8)	10.0(0.8)	14.2(0.6)	6.1( )
Site 2		15.3(0.8)	15.3(0.9)	16.5(0.6)	16.2( )
Site 3		11.8(0.8)	13.5(0.8)	14.7(0.6)	8.8( )
<u>Bank alteration</u>					
Site 1		42(-)	69(-)	59(-)	64(-)
Site 2		16(-)	27(-)	25(-)	23(-)
Site 3		34(-)	63(-)	55(-)	64(-)
<u>Fine sediments</u>					
Site 1	15.5( )	10.3(-)		21.2(-)	
Site 2	49.9(-)	45.1(-)		39.8(-)	
Site 3	48.1(-)	31.1(-)		34.4(-)	
<u>Width</u>					
Site 1		12.5(0.7)	13.3(0.8)	12.5(0.8)	17.9(1.0)
Site 2		11.7(0.7)	12.3(0.8)	11.7(0.8)	14.0(0.9)
Site 3		12.9(0.7)	13.8(0.8)	13.1(0.8)	18.2(1.8)
<u>Pool quality</u>					
Site 1		2.8(0.3)	3.1(0.3)	3.2(0.3)	3.2(0.3)
Site 2		3.6(0.3)	4.5(0.3)	4.1(0.3)	3.7(0.3)
Site 3		3.1(0.3)	3.9(0.3)	3.6(0.3)	3.2(0.4)
<u>Streambank angle</u>					
Site 1		136 (8)	134 (7)	121 (7)	123 (8)
Site 2		113 (8)	104 (7)	103 (7)	75 (8)
Site 3		138 (8)	124 (8)	125 (7)	125 (8)
<u>Streambank undercut</u>					
Site 1		0.08(.05)	0.10(.05)	0.19(.06)	0.19(.06)
Site 2		0.20(.05)	0.22(.05)	0.29(.06)	0.50(.09)
Site 3		0.07(.05)	0.14(.05)	0.18(.06)	0.23(.06)

Streambank angle (the higher the angle the more the bank is outsloped and the less value the bank has to the fishery) only increased slightly in the grazed sites, but they were already in an outsloped condition. In the ungrazed site, bank angle decreased by 27 percent from 1982 to 1984 to a current value of 75°. The large decrease in bank angle also caused a corresponding 72 percent increase in bank undercut, a move toward better salmonid conditions.

The habitat type (a vegetative classification by form) rating decreased dramatically in the grazed sites because of the large increase in newly eroded sediments dominating the streambank structure and the increase in exposed banks created by lateral movement and bank scour. Streambank alteration was much higher after the floods (1983-84) in the grazed sections but did not change much in the ungrazed section, reiterating the ability of the improved

stream-riparian condition in the ungrazed area to resist damage from unusual runoff events.

Heavy recreational fishing pressure effectively reduced trout numbers in site 2 (the livestock enclosure) because of better pool quality. This heavier fishing pressure makes it difficult to evaluate influences on fish populations from recent flooding. It is clear, however, that improved riparian-streambank condition in the ungrazed area has not benefitted the fish population. We believe this is because the large number of instream improvement structures trapped fine sediments, and offsite limiting factors (high water temperatures) from upstream grazed reaches cancel any of the benefits gained (Platts and Nelson<sup>3/7</sup>).

## CONCLUSIONS

Historically, researchers and managers have been interested in the effects from large flood events (Lyons and Beschta 1983; Gregory and Madew 1982). The runoff years of 1983 and 1984 were intensive, resulting in marginal to dramatic changes in riparian stream habitat of the three study streams. Where streamside vegetation was abundant, flood impacts were minimal.

Major mechanisms leading to changes in channel morphology and thus changes in fishery and riparian habitat, are the resistance of material to fluvial entrainment and the physical destruction of streambanks. These two mechanisms can be controlled, to some extent, by the types of land use and management in the riparian stream zone. If streambank vegetation is reduced, the stream usually responds by an adjustment of channel width. Physical destruction of the streambank results in delivery of sediments to the channel. The initial response of channels to these increased sediments is to reduce bedform roughness (Heede 1980; Jackson and Beschta 1984). In most cases this is accomplished by filling pools with sediments. Subsequent adjustments may include changes in width, depth, meander pattern or longitudinal profile. When these adjustments take place, riparian stream habitats suffer, and fish populations usually suffer.

## LITERATURE CITED

- Gregory, K. J., and J. R. Madew. 1982. Land use changes, flood frequency and channel adjustment. In: *Gravel-Bed Rivers*. R.D. Hey, J. C. Bathurst, C.R. Thorne, editors; John Wiley and Sons, N.Y. p 757-781.
- Heede, B. H. 1980. Stream dynamics: an overview for land managers, U.S.D.A. Forest Service, General Technical Report RM-12, Rocky Mountain, Forest and Range Exp. Sta., Ft. Collins, CO. 26 p.

- Jackson, W. L., and R. L. Beschta. 1984. Influences of increased sand delivery on the morphology of sand and gravel channels. *Wat. Res. Bull.* 20(4). p 527-533.
- Lyons, J. K., and R. L. Beschta. 1983. Land use, floods, and channel changes, Upper Middle Fork Willamette River, Oregon (1936-1980). *Water Resources Research*, Vol. 19, No. 2. p 463-471.
- Millard, M. D., G. A. Birdwell, R. B. Garrett, and G. W. Sandburg. *Water Resources Data, Utah, Water Year 1983*. U.S. Geological Survey Report UT-83-1, Salt Lake City, Utah.
- Platts, W. S., W. F. Megahan, and G. W. Minshall. 1983a. Methods for evaluating stream, riparian, and biotic conditions. *USDA Forest Service General Technical Report 183*, 70 p. Intermountain Forest and Range Experiment Station, Ogden, Utah.
- Platts, W. S., and R. L. Nelson. 1983. Population and generic differentiation in the Humboldt cutthroat trout of Gance Creek, Nevada. *Cal-Neva Wildlife Transactions*, p 15-19.
- Platts, W. S., R. L. Nelson, O. Casey, and V. Crispin. 1983b. Riparian-stream-habitat conditions on Tabor Creek, Nevada, under grazed and ungrazed conditions. *Western Proceedings: 63rd annual conference of the Western Association of Fish and Wildlife Agencies*. p 10-14.
- Ray, G. A., and W. F. Megahan. 1979. Measuring cross sections using a sag tape: a generalized procedure. *U.S. Forest Service General Technical Report INT-47*, Intermountain Forest and Range Experiment Station, Ogden, Utah. 12 p.

# Erosional Downtcutting in Lower Order Riparian Ecosystems: Have Historical Changes Been Caused by Removal of Beaver?<sup>1</sup>

Michael Parker<sup>2</sup>, Fred J. Wood, Jr.<sup>2</sup>, Bruce H. Smith<sup>3</sup>, and Robert G. Elder<sup>4</sup>

---

Streams often are described as being in a state of dynamic equilibrium. We hypothesize that, in lower order streams, beaver may be able to resist perturbations to this equilibrium if the perturbations are not too great. After suggesting the thermodynamic and mechanistic bases, we propose a simple model by which the potential of beaver to resist perturbations can be quantified. The model accounts for many common observations, and appears applicable to a variety of management problems.

---

## INTRODUCTION

Geologists often describe a stream as being in a state of dynamic equilibrium. Thus, assuming equilibrium initially, if conditions change the stream either begins to degrade (erode) or aggrade toward a new state. If the shift is toward increased erosion, then in general the capacity of the stream to entrain and transport particles must increase. The reverse must occur for aggradation to begin. Two factors commonly considered as varying to bring about altered conditions are climate and the intensity of grazing. These factors can perturb the equilibrium state in several ways. For example, they can alter the ease with which soil is eroded and increase or decrease the peak discharge occurring in the channel.

In this paper we suggest that an important factor affecting erosion and aggradation is commonly overlooked. Our general hypothesis is that, in lower order streams, the presence or absence of beaver respectively can cause increased aggradation or erosion. As a weak test of the

hypothesis we develop a model quantifying the ability of beaver to resist erosional perturbations.

First, thermodynamic and mechanistic bases for the model are established. Then we develop the model by considering how increasing discharge affects water velocity, and how water at different velocities causes erosion of different sized particles. In a final section we discuss some ways in which the model may be useful in managing erosion and other aspects of riparian ecosystems.

Some of the following discussion is rather simplified. Because at this writing we did not have critical data, we chose this approach purposefully. A portion of the work presented was supported by a grant from the Wyoming Water Research Center.

## A MODEL QUANTIFYING THE ABILITY OF BEAVER TO RESIST EROSIONAL PERTURBATIONS

Consider the following three statements: i) streams and their drainage basins exist in a state of dynamic equilibrium; ii) water moves downhill; iii) entropy increases. Most geomorphologists could agree with the first statement, especially given a chance to define terms and provide one or two explanations and/or qualifications. Literally, statements ii) and iii) are false. For example, water can be pumped upward into storage tanks, and, at least until death, all organisms exemplify localized systems which remain exceedingly organized through time. Thus it is only by putting energy into these systems (e.g., by burning petroleum to run a pump, by photosynthesizing, or by eating a steak) that statements ii) and iii) become false.

---

<sup>1</sup>Paper presented at the First North American Riparian Conference (The University of Arizona, Tucson, AZ, April 16-18, 1985).

<sup>2</sup>Michael Parker and Fred J. Wood, Jr., respectively, are Associate Professor of Zoology and a Graduate Student, University of Wyoming, Laramie, WY.

<sup>3</sup>Bruce H. Smith is District Wildlife Management Biologist and Program Leader, Bureau of Land Management, Rock Springs, WY.

<sup>4</sup>Robert G. Elder is an Environmental Specialist - Aquatic Ecologist, State of Wyoming Industrial Siting Administration, Cheyenne, WY.

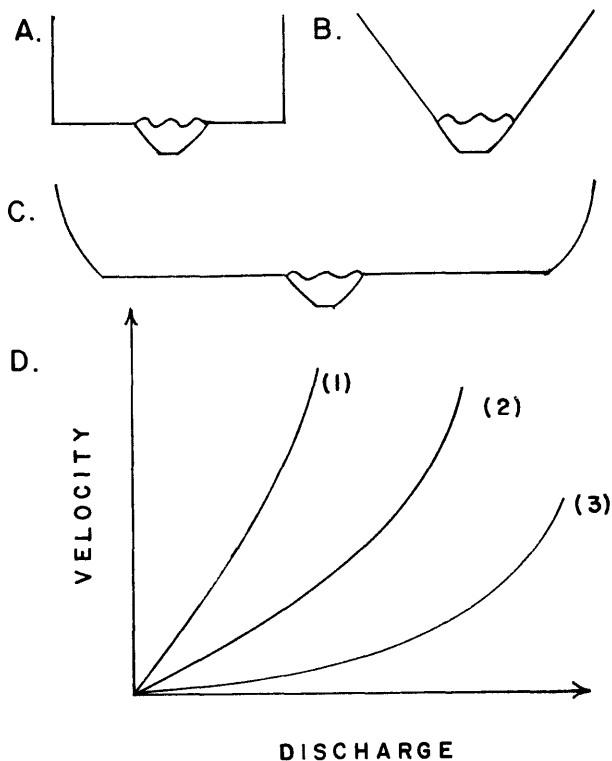

Figure 1. A, B, C: Schematic cross sections of three valleys. D: 1, 2 and 3 illustrate how water velocity varies as discharge increases in valleys, A, B and C.

Ideas in the preceding paragraph are related to riparian ecosystems by our main hypothesis, restated as: in smaller drainages, the activities of beaver can provide resistance to perturbations of the dynamic equilibrium if the perturbation is not too great. The thermodynamic basis for our hypothesis is that energy to resist a shift in equilibrium is provided by beaver and their activity. The beaver dam itself, a continuously renewed, erosionally resistant substrate, represents the mechanistic basis for the hypothesis.

We now develop a model of how beaver can resist erosional perturbations and hence gain, for example, the ability to predict whether a given perturbation is "...too great." First we need to determine what physical factors lead to persistence through time of a beaver dam. Persistence occurs when erosion of the dam-bank unit does not occur, so erosion is a key process to be considered. And, the power of water to erode is a function of velocity, which in turn is a function of slope, width and depth of stream, and bottom roughness. Note also that the velocity over a flooded bank will be affected by amount and type of vegetation (e.g., velocity will be much reduced if dense willow thickets are present).

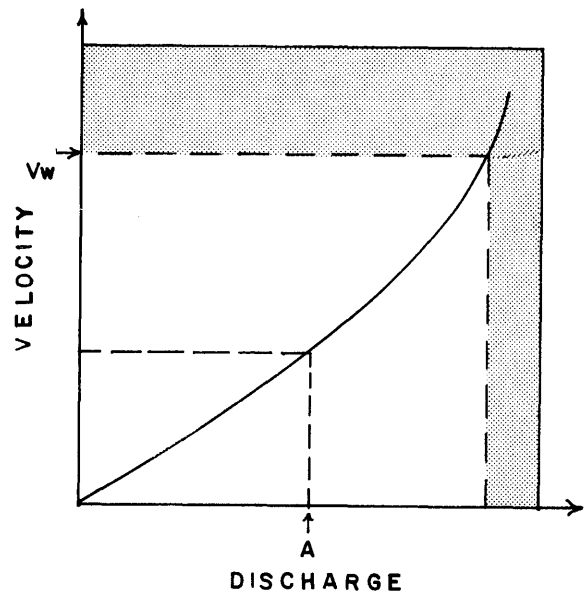

Figure 2. Water velocity as a function of discharge. A dam-bank unit will fail when velocity exceeds a critical threshold, the washout velocity ( $V_w$ ). Hence dam-bank units cannot exist in the shaded area. For a given discharge, vegetation with vertical structure will reduce the velocity of water flowing over banks. See text for explanation of point A.

Assume Manning's equation describes water velocity at a particular site:

$$V = (1.468/n) * R^{2/3} * S^{1/2}$$

where  $n$  = roughness coefficient,  $R$  = hydraulic radius,  $S$  = slope. At any location slope and roughness will not vary, while depth of water will depend on discharge. If  $R$  is approximated by mean depth then i) velocity will be a function of depth, and, because of the relation between depth and discharge, ii) velocity also will be a function of discharge (Fig. 1). A dam-bank unit will be unable to persist (unable to resist erosion) if, on a short-term basis, discharge produces a velocity exceeding a critical threshold, the washout velocity or  $V_w$  (Fig. 2, stippled area).

For a simple, initial quantification of the bank washout velocity ( $V_{wb}$ ) we can use empirical relations between the size of a particle and the water velocity required for its erosion (Fig. 3). There seems to be no equivalent equation to predict the dam washout velocity ( $V_{wd}$ ), but empirical data easily could be collected. Thus we now have a quantitative framework for predicting when a beaver dam should be able to persist through time.



Next, consider bank and dam erosion as independent processes. Vegetation affects the depicted relations for banks in two ways. i) Vegetation with vertical structure (e.g., willow thickets) impedes water movement, decreases velocity, and increases the discharge required to exceed the bank washout velocity. ii) Vegetation without vertical structure will affect velocity little but still protects soil from erosion, and hence again the discharge needed to exceed  $V_{wb}$  increases.

The effect of vertical vegetative structure can be incorporated in our model via  $n$ , the roughness coefficient. We calculate velocity over the bank (e.g., in the willow thicket) separately from that in the channel, and use a markedly different value for the roughness coefficient of the bank. For example, the largest value of  $n$  presented by Barnes (1967) was calculated for a bank with dense standing and downed saplings. Similarly, a way to account for vegetation protecting particles from erosion is by a coefficient analogous to  $K$ , the soil erodibility factor used in soil erosion calculations. In this case the vegetation does not affect our calculation of water velocity, but rather increases the bank washout threshold,  $V_{wb}$ .

Finally, we note how the model can be used to quantify the ability of beaver to resist perturbations which otherwise might cause erosional downcutting. Assume that point A on Figure 2 represents the presently attained maximum annual discharge (or maximum two- or five- or ten-year flood, if those would be more appropriate). The distance between point A and the point where shading begins on the abscissa represents the potential of beaver to resist an erosion-causing perturbation (more realistic treatments will have to consider the effects of altered vegetation). Thus we can measure the potential of beaver to resist changes in erosional equilibrium with the same units employed to measure discharge.

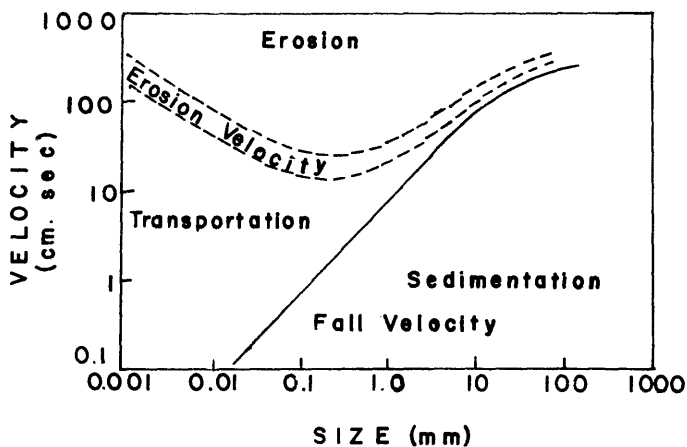

Figure 3. Relation between size of substrate particle and the water velocity required for erosion, transport or sedimentation. Vegetative cover on the bank will increase the velocity needed for erosion to occur. After Hjulstrom (1935).

Note that our simple model accounts for many common observations. Dam-bank units can fail because of dam blow-out ( $V_{wb} > V_{wd}$ ), or by erosion of banks ( $V_{wd} > V_{wb}$ ). Vegetation protects against bank washout. Downcut streams, with narrow channels promoting greater water depth and water velocities during high discharge, are unlikely to support persistent dams. And, because the abscissa could have units of stream order (order is related to discharge), we predict only smaller streams support beaver dams; large rivers have bank-dwelling beaver.

#### SOME APPLICATIONS OF THE MODEL RELATING TO EROSION AND OTHER ASPECTS OF RIPARIAN ECOSYSTEMS

In Wyoming marked changes in riparian zones have occurred over the past century or so. For example, Shute (1981) estimated that over 80 per cent of the badly downcut streams in one area did not exist 100 years ago. In 1905 one had to stoop to pass beneath the bridge over Muddy Creek at Dad, Wyoming (E. Solace, personal communication); at that site today Muddy Creek is in a trench 15 to 20 feet deep. Aerial photos also appear to document marked changes in this creek's riparian zone, especially vegetation, over the relatively short period since 1939. Of course this list is not complete, and many other examples of changed riparian zones exist.

Climate and grazing are two commonly suggested causative factors mentioned in relation to trends in degradation or erosional downcutting of streams. We suggest, for smaller streams, that the presence/absence of beaver also may be important. However, because all these factors involve some common mechanisms, it is not easy to determine if one or several of the three factors caused the changes observed at a specific location. The difficulty in sorting out causes is exacerbated in many places because the introduction of grazing tended to coincide with removal of beaver.

This difficulty in assigning cause may be complicated additionally by several not-so-obvious activities of ranching. For example, fur trapping must have been important in depressing or eliminating populations of beaver in some areas (e.g., Collier 1959). But, for two reasons, in some areas of the arid west the demands of ranching also must have been important in affecting beaver. First, production of hay required diversions of stream water, and beaver actively dammed the diversion ditches (E. Solace, personal communication). Second, while riparian areas supported the most lush and productive vegetation, some of these areas could be little used for grazing. This is because when the soils are saturated with water, cattle venturing onto them become mired and die. And, by keeping water tables high in these meadows, beaver caused the problem. Thus two sources of reduced stock production could be eliminated by the same actions: killing beaver and destroying their dams.

The points we wish to make here are as follows. First, the effects of beaver should be considered when trying to explain a variety of changes in small riparian systems. Second, our model should help to determine whether removing beaver could have played a role in any given (recent) riparian changes. It would be useful, for example, in deciding whether changes brought about by a hydrologic regime altered via climate and/or grazing might have been resisted were beaver present. Only if this was a possibility might it be worth further considering the role of beaver at the site. But, considering the role of beaver in causing riparian changes may make sense of some otherwise puzzling occurrences.

Beaver affect water and riparian zones in several additional ways. For example, the amount of surface water is markedly increased by dams. Lang and Weider (1984) suggest that in West Virginia beaver have altered the structure of forests. The changes in valley bottoms are attributed to ponds and a high water table caused by beaver dams.

Another important aspect of beaver dams, especially in moderately broad valleys, is to decrease peak discharge during a runoff event. This occurs because each dam has some storage capacity as the water level water in the pond increases a few inches during the event. While any one dam stores only a relatively small amount of water in this way, a large number of dams in aggregate can have a great effect.

When increased discharge flows into an area with beaver dams, we observe a major effect of beaver on riparian systems; the flow is spread over a wide linear distance. Thus instead of being a relatively deep but narrow flow, as would occur in a trench, the flow is shallow and wide. This is significant because the velocity of the stream, and hence its ability to erode, is reduced considerably.

Yet another result associated with ponds and high water tables is increased bank and ground storage. This happens because as well as physically keeping the level of water at a higher elevation, dams increase the area of water-land interface. Such increased water-land contact also will occur during periods of flooding, leading to increased storage from storm events. Collier (1959), for example, provides an account of how reintroducing beaver apparently led to greater flows from a drainage during late summer.

Moving from hydrology to water quality, we have found that a beaver dam complex significantly reduces the concentrations of suspended solids, total Kjeldahl nitrogen, and total phosphorus. Because the origin of all these parameters is from non-point sources, beaver may be useful in reducing nutrient and sediment export. However another of our observations emphasizes i) the need to consider the drainage system as a whole, and ii) that while important, beaver are only a part of this system. The beaver complex we studied improved water quality as indicated. But, about a mile downstream from the study area water quality had deteriorated and no effects from the beaver complex were evident. In this mile the stream is somewhat downcut, and there is considerable bank erosion. Hence the mid-basin improvement of water quality would be of little use if the goal was to reduce nutrient export into a lake or reservoir a mile below the beaver area.

Our last point is that many attributes of riparian zones, hydrology, and water quality are significantly and positively affected by the activity of beaver. And, in particular situations it may be feasible to use beaver as part of a larger management strategy directed at achieving a certain goal. The success of this strategy may depend on whether beaver dams can be established. Our model holds the potential for determining, in advance, how far down a drainage it would be feasible to use beaver dams as a management tool.

#### REFERENCES

- Barnes, H.H., Jr. 1967. Roughness characteristics of channels. USGS Water-Supply Paper 1849.
- Collier, E. 1959. Three Against the Wilderness. E.P. Dutton & Co., New York, NY.
- Hjulstrom, F. 1935. Studies of the morphological activity of rivers as illustrated by the River Fyris. Bulletin of the Geological Institute, University of Uppsala 25:221-527.
- Lang, G.E. and R.K. Weider. 1984. The role of beaver in vegetation patterning and development in Sphagnum-dominated wetlands in West Virginia. Bull. Ecological Soc. Amer. 65(2):243.
- Shute, D.A. 1981. Decline of riparian communities in a portion of southwestern Wyoming. Unpublished Report, Wyoming Natural Heritage Program - The Nature Conservancy, Cheyenne, WY 10p.

# The Development of Southwestern Riparian Gallery Forests<sup>1</sup>

Ward Brady, David R. Patton, and Jay Paxson<sup>2</sup>

---

Abstract.--Riparian gallery forests along two rivers in the southwestern United States are described in a developmental continuum ranging from nursery bar to mature forest. Habitats suitable for tree reproduction are recognizable by their position relative to the active water course. These sites are typically located in overflow channels and receive flow only during floods. Flooding and the subsequent aggradation appear to be the major variables for the natural sequence of development within riparian stands.

---

## INTRODUCTION

Importance of the riparian communities for wildlife habitat has been well described in the literature (Bristow 1969, Carothers 1977, Gallizioli 1965, Todd 1972). Other equally important resource values include aesthetics, livestock grazing, recreation, and watershed protection. Better understanding of these communities is important if these values are to be preserved because various use-related pressures such as channelization, phreatophyte control, water impoundment, and grazing threaten to further reduce the extent of these communities.

Literature concerning patterns of temporal and spatial development of riparian communities is limited. Glinski (1977) discussed temporal aspects of riparian regeneration. Other authors have discussed classification systems (Brown 1982, Dick-Peddle and Hubbard 1977, Pase and Layser 1977); wildlife importance (Anderson and Ohmart 1977, Hubbard 1977, Johnson et al. 1977); management systems (Brown et al. 1977, Davis 1977); and grazing impacts (Ames 1977, Platts 1979, Szaro and Pase 1983, Thomas et al. 1979).

This paper reports on studies which were initiated on the structural characteristics of two typical riparian gallery forests in the southwestern United States which led to a hypothesis concerning developmental processes

within the forest. The developmental processes within these forests occur over very long time sequences, therefore an understanding of these processes is difficult to acquire by direct observation. However, by observing the characteristics of stands which are at different stages of development, inferences can be drawn and hypotheses formulated regarding the processes which produce the observed vegetation structure. The objective of this paper is to describe the developmental processes hypothesized to occur in riparian gallery forests of the Southwest.

## Study Areas

Two study areas were selected which were felt to be representative of well-developed riparian gallery forests in the Southwest. The Gila River Bird Habitat Area, (hereafter termed Gila BHA) was 16 km southwest of Cliff, New Mexico. The Winkelman study area was 7 km southeast of Winkelman, Arizona, and was on the San Pedro River. Both sites exhibited a developmental continuum from seedling through mature stands.

The Gila BHA was 1,310 m above sea level with steep adjacent mountains over 1,830 m in elevation. Riparian vegetation was dominated by Fremont cottonwood (*Populus fremontii* Wats.), Goodding willow (*Salix gooddingii* Ball), and Arizona sycamore (*Platanus wrightii* Wats.). Surrounding upland vegetation varied from desert/shrub/grassland type on drier, more level sites to oak-juniper-pinyon woodland on steeper hillsides and in ephemeral drainages. Dominant species included western honey mesquite (*Prosopis juliflora* (Swartz) DC. var. *torreyana* Benson), grama grasses (*Bouteloua* spp.), pinyon pine (*Pinus edulis* Engelm.), one-seed juniper (*Juniperus monosperma* (Engelm. Sarg.), and gray oak (*Quercus griesea* Liebm.). Nomenclature follows Kearney and Peebles (1960).

---

<sup>1</sup>Paper presented at the Riparian Ecosystems and their Management: Reconciling Conflicting Uses Conference. [Tucson, Arizona, April 16-18, 1985]

<sup>2</sup>Ward Brady is Associate Professor of Department of Agriculture, Arizona State University, Tempe, Arizona; David R. Patton is Principal Wildlife Biologist, USDA Forest Service, Arizona State University Campus, Tempe, Arizona; and Jay Paxson is Range Conservationist, USDA Forest Service, Pinetop, Arizona.

The Winkelman study site, in contrast, was 575 m above sea level with a surrounding topography of gently rising alluvial fans which terminated on steep mountain slopes, the highest of which reached 1,375 m. The riparian community was dominated by Fremont cottonwood, Goodding willow, and saltcedar (*Tamarix pentandra* Pall.). Surrounding upland vegetation was typical Upland Sonoran Desert Shrub. Dominant species included foothill paloverde (*Cercidium microphyllum* (Torr.) Rose and Jonst.) and creosotebush (*Larrea tridentata* DC. Coville). Associated species included ocotillo (*Fouquieria splendens* Engelm.) and *Opuntia* species.

Both the Gila and Winkelman study areas were characterized by winter-summer precipitation and spring-fall drought (Kincer 1922, Jurwitz 1953). The summer precipitation was in the form of cyclonic storms. Winter precipitation in particular was highly variable from year to year (Sellers 1960, Sellers and Hill 1974).

#### METHODS

Well-defined perennial stands, lenticular to elliptical in outline, typified the Gila BHA and Winkelman study areas. These stands were discernable by the limits of their canopies. Stands were selected to represent a cross section of stand ages as inferred by Diameter at Breast Height (DBH) measurements. Selected stands were required to be visually homogeneous and of sufficient extent to accommodate a minimum of four appropriately sized sample plots. Seedling stands, having a majority of trees <5 cm DBH were sampled using 1/2 m<sup>2</sup> rectangular plot frames. Mature and sub-mature stands having the majority of overstory individuals >5 cm DBH were sampled using a 10 m x 20 m rectangular plot.

Each stand was sampled along its main axis parallel to the river channel. Placement of the first sample plot was randomly determined, as was the intra-stand distance between sample plots. The following data were recorded: (a) soil type and texture; (b) distance of the stand from the active river course; (c) mean canopy height; (d) overstory canopy cover; (e) all overstory individuals by species; (f) DBH of overstory >5 cm; (g) estimated understory cover by species. Twelve stands were sampled using 72 plots. Stands were categorized based on relative developmental status as: nursery-bar, sub-mature, and mature. Stands 1 through 8 represent the Gila BHA, while stands 9 through 12 represent the Winkelman study area.

#### RESULTS

The youngest stands were described as either seedling nursery-bars (Stands 2 and 6), or sapling nursery-bars (Stands 1, 7, 9, 11, and 12). Seedling nursery-bars were composed of overstory individuals <5 cm DBH. Sapling nursery-bars, on the other hand, included individuals larger and smaller than 5 cm DBH. The mean DBH for individuals >5 cm varied between 8.21 and 9.17 cm (tables 1, 2, and 3).

Table 1.--Composition, density, basal area, and developmental status of selected riparian forest stands

Stand #	Overstory species	Overstory density (#/ha)	Overstory basal area (m <sup>2</sup> /ha)	Regeneration density (#/ha)	Stand type designation
2	Pofr <sup>1</sup>	-0-	-0-	123,077	S-NB <sup>2</sup>
	Sago	-0-	-0-	67,692	
6	Pofr	-0-	-0-	88,000	S-NB
	Sago	-0-	-0-	6,000	
1	Pofr	12,308	80.98	29,231	A-NB
	Sago	4,615	26.73	9,231	
7	Pofr	15,714	61.01	42,857	A-NB
	Sago	-0-	-0-	1,429	
9	Pofr	1,401	8.90	1,977	A-NB
	Sago	329	3.02	329	
	Tape	41	0.08	329	
	Prju	-0-	-0-	206	
11	Pofr	8,000	27.64	118,000	A-NB
	Sago	-0-	-0-	10,000	
	Tape	-0-	-0-	14,000	
12	Pofr	2,965	90.05	10,734	A-NB
	Sago	198	9.28	-0-	
	Tape	-0-	-0-	1,829	
	Sasa	-0-	-0-	99	
	Prju	-0-	-0-	49	
5	Pofr	770	119.26	640	SM
	Sago	110	15.07	100	
	Cere	-0-	-0-	50	
8	Pofr	1,220	216.63	1,480	SM
	Sago	200	16.79	1,030	
	Tape	-0-	-0-	50	
10	Pofr	684	23.59	-0-	SM
	Sago	134	1.35	8	
	Tape	75	0.24	2,634	
	Sasa	-0-	-0-	25	
	Frve	-0-	-0-	50	
	Prju	-0-	-0-	75	
3	Pofr	20	35.41	-0-	M
	Plwr	80	18.80	-0-	
	Sasa	30	2.52	320	
	Frve	90	9.19	-0-	
	Juni	40	0.80	72	
	Cere	-0-	-0-	14,200	
4	Pofr	320	100.66	-0-	M
	Sago	200	15.66	-0-	
	Acne	10	0.83	-0-	

<sup>1</sup> Pofr = *Populus fremontii*  
 Sago = *Salix gooddingii*  
 Tape = *Tamarix pentandra*  
 Prju = *Prosopis juliflora*  
 Sasa = *Sapindus saponaria*  
 Cere = *Celtis reticulata*  
 Frve = *Fraxinus velutina*  
 Plwr = *Platanus wrightii*  
 Juni = *Juniperus* spp.  
 Acne = *Acer negundo*  
<sup>2</sup> S-NB = Seedling nursery-bar stand  
 A-NB = Sapling or adolescent nursery-bar stand  
 SM = Sub-mature stand  
 M = Mature stand

Table 2.--Developmental status and geographic relationship to river course

Stand #	Stand developmental status	Elevation above present river level (m)	Tree canopy height (m)	Estimate <sup>2</sup> of survival (%)	Baccharis glutinosa presence
2	S-NB <sup>1</sup>	0.5	0.9	0.0	yes
6	S-NB	1.4	2.4	0.0	yes
1	A-NB	0.9	4.6	90-95	yes
7	A-NB	1.7	7.6	98	yes
9	A-NB	1.1	7.6	85	yes
11	A-NB	1.1	4.6	95	yes
12	A-NB	2.0	7.0	60	yes
5	A-NB	1.7	22.9	85-90	yes
8	SM	0.9	21.3	95	yes
10	SM	1.1	18.3	95	yes <sup>3</sup>
3	M	1.4	33.5	90-95	no
4	M	2.6	35.1	98	yes

<sup>1</sup> S-NB = seedling nursery-bar stand, A-NB = sapling or adolescent nursery-bar stand, SM = sub-mature stand, and M = mature stand.  
<sup>2</sup> Ocular estimate of stand survival percentage following 100-200 year floods of November-December 1978.  
<sup>3</sup> Dead *Baccharis glutinosa* was observed in stand #3.

Table 3.--Relative density of Fremont cottonwood by diameter classes (%)

Stand #	Stand development status	Diameter classes (%)			
		< 5 cm	5+-20 cm	20+-40 cm	> 40 cm
2	S-NB <sup>1</sup>	100	-0-	-0-	-0-
6	S-NB	100	-0-	-0-	-0-
1	A-NB	69.5	30.5	-0-	-0-
7	A-NB	73.8	26.2	-0-	-0-
9	A-NB	56.6	42.3	1.0	-0-
11	A-NB	94.1	5.9	-0-	-0-
12	A-NB	77.6	22.4	-0-	-0-
5	SM	12.9	52.5	33.6	1.0
8	SM	26.1	44.2	28.1	1.6
10	SM	6.1	55.3	38.6	-0-
3	M	-0-	12.0	48.0	40.0
4	M	-0-	11.5	46.2	42.3

<sup>1</sup> S-NB = seedling nursery-bar stand, A-NB = sapling or adolescent nursery-bar stand, SM = sub-mature stand, M = mature stand.

These stands developed upon bars or shoals composed of fine sediments. Little or no regeneration of Fremont cottonwood took place on other micro-habitats. Nursery-bars exhibited a lenticular to ribbon-like shape. Vegetation was composed of tree seedlings, associated shrub species, forbs, and grasses. The dominant was Fremont cottonwood.

Sub-mature stands (Stands 5, 8, and 10) exhibited reduced regeneration of mesic riparian (as compared with semi-riparian) species, and had larger Fremont cottonwoods ( $\bar{x}$  = 21.1 cm DBH) than nursery-bar stands (tables 1, 2, and 3). Trees within these stands were physically mature; however, the stands represented an intermediate developmental stage. Less regeneration occurred and a greater spectrum of size classes were present. The habitat in which these stands were found was shaded with dry, well-drained, fine-textured substrates.

Mature stands exhibited no regeneration of riparian species (Stands 3, 4), and had the largest Fremont cottonwood individuals (63.8 to 149.3 cm DBH) (table 1). Trees were physically mature, and the stands were approaching the end of developmental sequence. The habitat was similar to the sub-mature, except they were further elevated above the present river channel.

## DISCUSSION

### Nursery-bars

Nursery-bars were located in overflow channels on both study areas. Miller (1970) discussed the formation of these secondary channels within the floor plain. Crescent-shaped bars were formed by the nonuniform accretion of alluvium on the inner side of a stream bend. High flows temporarily turned the alluvial deposit into an island with a secondary channel behind it. Other overflow channels appeared as abandoned meanders or oxbows of

primary channels. The depth of scouring in these oxbows may approach ground water, providing ideal conditions for establishment of hydrophytic species. Because of reduced water velocities, secondary channels often appeared as vegetated furrows, whereas the main streamcourse was kept barren by scouring at times of flood.

As flows in the primary channel increase in volume, these overflow channels also receive increasing flows, however, the relative velocities are reduced by friction of overland flow, reduction in volume, and usually by a reduction in stream gradient. Therefore, the degree of protection to young vegetation which any particular overflow channel provides to an existing nursery depends largely on the vertical and horizontal distance from the main stream which any flood flow must traverse. Major flooding events are potentially destructive because overflow channels provide a natural pathway for water flow.

Another factor which reduced the velocity of water in overflow channels was the presence of vegetation and debris. Seepwillow (*Baccharis glutinosa* Pers.) may be particularly important in this respect. Live seepwillow was observed in 92% of all stands sampled (table 2). Seedlings of seepwillow were found in all nursery-bar stands. The regularity of occurrence of this species suggests the possibility that a nurse-plant relationship may exist between tree seedlings and seepwillow. At least the presence of seepwillow is closely associated with the establishment of stands. Seepwillow averaged 24% of total ground cover in sapling nursery-bars, providing some protection from flooding. Reduced water velocities also results in sediment deposition and possible expansion of the nursery-bar (Miller 1970). Glinski (1977) related a flooding occurrence on Sonoita Creek in Santa Cruz County, Arizona, where only cottonwood and willow growing among stands of seepwillow survived.

### Sub-Mature and Mature Stands

Observations at both study areas suggested that mature to sub-mature stands of cottonwood-willow may result from the coalescing of smaller nursery-bars into a larger stand (fig. 1). The hypothetical mechanism for this coalescing follows: Seepwillow and other riparian shrubs reduce and redirect flow volumes and velocities in and around nursery-bar stands during light or moderate floods. Reduced flow velocities also result in deposition of sediments, which creates additional substrate favorable to establishment of seedlings. When this micro-habitat development coincides with production of viable seed, potential for abundant regeneration is created. If this occurs over a period of several years, numerous nursery-bars become established and grow together appearing as a single macro-stand. Successful stand occurrence, however, depends largely on favorable flood volumes during the developmental period.

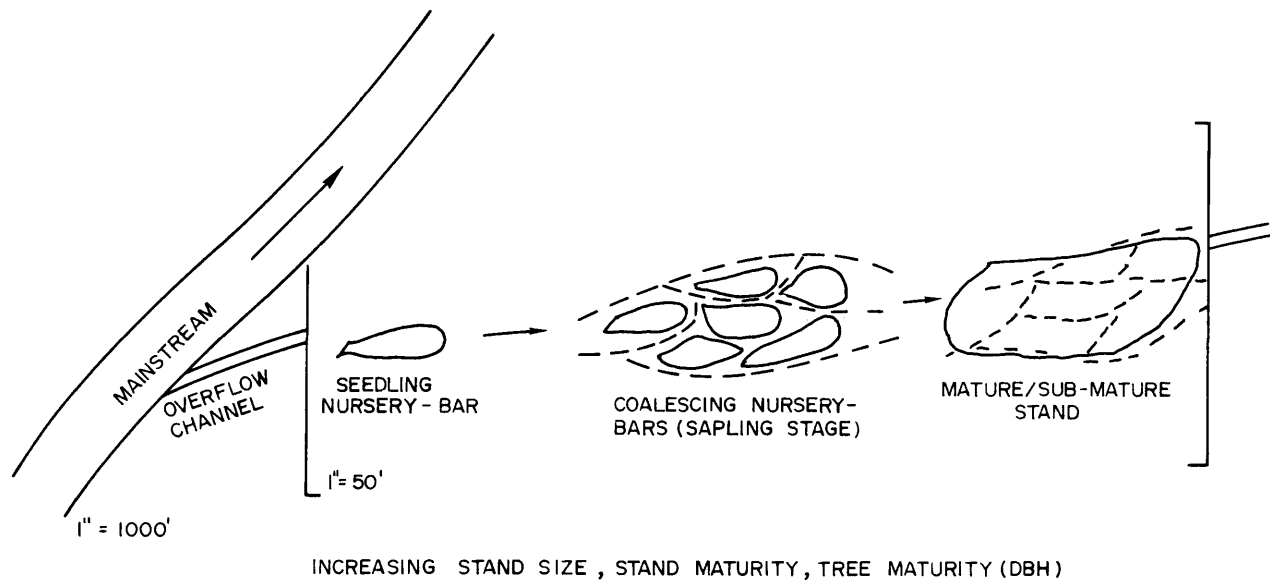

Figure 1.--Riparian development sequence showing coalescing of seedling nursery-bars in an overflow channel into a mature stand.

Age distributions inferred from DBH measurements (table 3) indicated that as stands mature, the habitat became progressively less suitable for regeneration. Little or no regeneration of mesic riparian species takes place in stands which have developed beyond the nursery-bar stage. Shading, aggradation within the stand due to sediment deposition, shifting river patterns, and possibly other factors combine to provide adverse conditions for seedling establishment.

Stands which have developed to the mature or sub-mature stage seem isolated and/or pedestaled. Field observations suggest that both aggradation within and degradation around a particular stand may account for this phenomenon. Wolman and Leopold (1970) reported that natural levees may be formed by sediment being entrapped in streamside vegetation. They also discussed specific examples of aggradation, ranging from several cm to several m which occurred at times of peak flood, calling the phenomenon overbank deposition.

Numerous examples were noted at both study areas where trunks of overstory species appeared buried. Partial excavation of several trees revealed that the main stem of the trunk continued to a greater depth. During periods of high stream flow, suspended sediments were carried into these stands where they are deposited. The process, repeated many times and in sufficient magnitude, may help explain this phenomenon. Examination of cutbanks adjacent to these stands revealed obvious grading and cross-bedding which supports this hypothesis. Stands appeared to be elevated in the study areas 1.5 m or more (in a few cases up to 3 m) above the present river level. Additionally, masses of

driftwood and other debris lodged among the trees further supports the possibility that such hydraulic activity explains the apparent elevation of stands and individuals.

#### SUMMARY

Establishment and development of southwestern riparian gallery forests appears to follow an orderly, well-defined sequence. Starting with the creation of favorable seedbed, stands progress from nursery-bars to senescent individuals as habitat is continually modified. The riverine system plays an important role in the survival and development of these stands. Flooding, when light or moderate, favors establishment and development through deposition of nutrient-rich sediments and increased soil moisture. Successful regeneration cannot be expected on an annual basis, since it depends greatly on a "proper sequence of flooding," i.e., no flood large enough to be catastrophic until any given stand is sufficiently well developed to provide its own protection. Major flooding is catastrophic, regardless of the developmental stage.

#### LITERATURE CITED

- Ames, Charles R. 1977. Wildlife conflicts in riparian management: Grazing. p. 49-51. In Importance, preservation and management of riparian habitat: Proceedings of the symposium, R. Roy Johnson and Dale A. Jones (tech. coords.) USDA Forest Service General Technical Report RM-43, 217 p. Rocky Mountain Forest and Range Experiment Station, Fort Collins, Colo.

- Anderson, Bertin W., and Robert D. Ohmart. 1977. Vegetation structure and bird use in the Lower Colorado River Valley. p. 23-24. In Importance, preservation and management of riparian habitat: Proceedings of the symposium, R. Roy Johnson and Dale A. Jones (tech. coords.) USDA Forest Service General Technical Report RM-43, 217 p. Rocky Mountain Forest and Range Experiment Station, Fort Collins, Colo.
- Bristow, Bud. 1969. Land and water projects investigations, investigation of proposed projects. Arizona Game and Fish Department, Completion Report Project FW-16-R-8, J1, 23-27. Phoenix, Ariz.
- Brown, David E. (ed.) 1982. Biotic communities of the American Southwest-United States and Mexico. 342 p. Desert Plants 4(1-4).
- Brown, David E., Charles H. Lowe, and Janet F. Hausler. 1977. Southwestern riparian communities: Their biotic importance and management in Arizona. p. 201-211. In Importance, preservation and management of riparian habitat: Proceedings of the symposium, R. Roy Johnson and Dale A. Jones (tech. coords.) USDA Forest Service General Technical Report RM-43, 217 p. Rocky Mountain Forest and Range Experiment Station, Fort Collins, Colo.
- Carothers, Steven W. 1977. Importance, preservation, and management of riparian habitats: An overview. p. 2-4. In Importance, preservation and management of riparian habitat: Proceedings of the symposium, R. Roy Johnson and Dale A. Jones (tech. coords.) USDA Forest Service General Technical Report RM-43, 217 p. Rocky Mountain Forest and Range Experiment Station, Fort Collins, Colo.
- Davis, Gary A. 1977. Management alternatives for the riparian habitat in the Southwest. p. 59-67. In Importance, preservation and management of riparian habitat: Proceedings of the symposium, R. Roy Johnson and Dale A. Jones (tech. coords.) USDA Forest Service General Technical Report RM-43, 217 p. Rocky Mountain Forest and Range Experiment Station, Fort Collins, Colo.
- Dick-Peddie, William A., and John P. Hubbard. 1977. Classification of riparian vegetation. p. 85-90. In Importance, preservation and management of riparian habitat: Proceedings of the symposium, R. Roy Johnson and Dale A. Jones (tech. coords.) USDA Forest Service General Technical Report RM-43, 217 p. Rocky Mountain Forest and Range Experiment Station, Fort Collins, Colo.
- Gallizioli, Steve. 1965. Phreatophytes and wildlife. p. 317-319. In Minutes, Phreatophyte Subcommittee Meeting, Pacific Interagency Committee, Vol. 2, Jan. 1960-Dec. 1966.
- Glinski, Richard L. 1977. Regeneration and distribution of sycamore and cottonwood trees along Sonolita Creek, Santa Cruz County, Arizona. p. 116-123. In Importance, preservation and management of riparian habitat: Proceedings of the symposium, R. Roy Johnson and Dale A. Jones (tech. coords.) USDA Forest Service General Technical Report RM-43, 217 p. Rocky Mountain Forest and Range Experiment Station, Fort Collins, Colo.
- Hubbard, John P. 1977. Importance of riparian ecosystems: Biotic considerations. p. 14-18. In Importance, preservation and management of riparian habitat: Proceedings of the symposium, R. Roy Johnson and Dale A. Jones (tech. coords.) USDA Forest Service General Technical Report RM-43, 217 p. Rocky Mountain Forest and Range Experiment Station, Fort Collins, Colo.
- Johnson, R. Roy, Lois T. Haight, and James M. Simpson. 1977. Endangered species vs. endangered habitats: A concept. p. 68-79. In Importance, preservation and management of riparian habitat: Proceedings of the symposium, R. Roy Johnson and Dale A. Jones (tech. coords.) USDA Forest Service General Technical Report RM-43, 217 p. Rocky Mountain Forest and Range Experiment Station, Fort Collins, Colo.
- Jurwitz, L. R. 1953. Arizona's two-season rainfall pattern. Weatherwise 6:96-99.
- Kearney, T. H., and R. H. Peebles. 1960. Arizona flora. 1,085 p. University of California Press, Berkeley.
- Kincer, J. B. 1922. Precipitation and humidity. p. 179. In Atlas of American Agriculture. U.S. Printing Office, Washington, D.C.
- Miller, H. 1970. Methods and results of river terracing. p. 19-35. In Rivers and river terraces, G. H. Dury (ed.). Macmillan and Co., Ltd., London.
- Pase, Charles P., and Earle F. Layser. 1977. Classification of riparian habitat in the Southwest. p. 5-9. In Importance, preservation and management of riparian habitat: Proceedings of the symposium, R. Roy Johnson and Dale A. Jones (tech. coords.) USDA Forest Service General Technical Report RM-43, 217 p. Rocky Mountain Forest and Range Experiment Station, Fort Collins, Colo.
- Platts, William S. 1979. Livestock grazing and riparian/stream ecosystems: An overview. p. 39-45. In Forum-grazing and riparian/stream ecosystems, O. B. Cope, ed. Trout Unlimited, Inc.
- Sellers, W. D., editor. 1960. Arizona climate. University Arizona Institute of Atmospheric Physics. 616 p. University of Arizona Press, Tucson.
- Sellers, W. D., and R. H. Hill. 1974. Arizona climate: 1931-1972. University of Arizona Press, Tucson.
- Szaro, Robert C., and Charles P. Pase. 1983. Short-term changes in a cottonwood-ash-willow association on a grazed and an ungrazed portion of Little Ash Creek in central Arizona. Journal of Range Management 36:382-384.
- Thomas, Jack W., Chris Maser, and John E. Rodrek. 1979. Riparian zones in managed rangelands--their importance to wildlife. p. 21-30. In Forum-grazing and riparian/stream ecosystems, O. B. Cope (ed.). Trout Unlimited, Inc., Denver, Colo.
- Todd, Richard L. 1972. Biological report on a marsh near Tuzigoot National Monument. Arizona Game and Fish Department Special Report W-53-23. 4 p.
- Wolman, M. G., and L. B. Leopold. 1970. Flood plains. p. 166-196. In Rivers and river terraces. Macmillan and Co., Ltd., London.

# Interdependence of Groundwater, Riparian Vegetation, and Streambank Stability: A Case Study<sup>1</sup>

David P. Groeneveld and Thomas E. Griepentrog<sup>2</sup>

---

Abstract. Groundwater is closely coupled with streamflow to maintain water supply to riparian vegetation, particularly where precipitation is seasonal. A case study is presented where Mediterranean climate and groundwater extraction are linked with the decline of riparian vegetation and subsequent severe bank erosion on the Carmel River in Carmel Valley, California.

---

## INTRODUCTION

By their nature, riparian systems require far greater amounts of water than other terrestrial ecosystems. Groundwater is often a critical source of supply to maintain the riparian zone, particularly in climatic regions with seasonal precipitation. The slow drainage by aquifers which intersect streamcourses serves to maintain channel flow during dry periods and to support the plant species which structure the productivity and character of the riparian ecosystem. This balance may be particularly sensitive to alteration. Removal of water from the system below a certain threshold equates to reduced productivity since water stress necessitates stomatal closure and loss of carbon fixation. This is especially so with riparian species since they are adapted to moist habitats and are, as a group, relatively intolerant to drought stress. Repeated or prolonged removal of water from the system, especially during dry periods may therefore induce severe impact to riparian vegetation.

Alluvial valley fill is generally an excellent source of groundwater to supply man's needs where high permeability, storage and rapid recharge from streambed infiltration exist. This is true of the Carmel Valley aquifer which is tapped for supply to regional development and the Monterey Peninsula in particular.

This study documents the link between the groundwater extraction from the Carmel Valley aquifer and the decline of riparian vegetation along a two mile section of the Carmel River. Subsequent severe bank erosion along the impacted

stretch can be explained by loss of root stabilization.

Groundwater development, while necessary for man's activities, should be sensitive to potential impacts and be planned accordingly. The potential for degrading riparian areas and subsequent erosion is widespread in western North America. In addition to the Carmel River, groundwater pumping has been implicated in impacts to riparian systems along the Platte River drainage in Colorado<sup>3</sup>, the Arkansas River in Kansas and Oklahoma<sup>4</sup>, the Owens River drainage in California<sup>5</sup> and the Gila River drainage in Arizona (Judd, et al. 1971).

## PHYSICAL CHARACTERISTICS

The Carmel River drains an area of 255 square miles in the northern Santa Lucia Mountains of California's Coast Range. The watershed extends from a divide elevation of over 5,000 feet to sea level where the river discharges into the Pacific Ocean just south of Monterey Bay.

Physical characteristics distinguish the Carmel River's upper and lower reaches. The upper river and its tributaries flow in steep, narrow, "V" shaped canyons cut into Pre-Tertiary igneous and metamorphic bedrock. In its lower 15 miles, the Carmel River flows through an alluvium-filled basin underlain by Miocene marine shales. The alluvial soils of the Carmel floodplain are typically poorly developed and coarse textured.

---

<sup>3</sup>Glenn L. Crouch. 1982. Personal conversation. U.S. Forest Service, Rocky Mountain Forest and Range Exp. Sta., Fort Collins, Colorado.

<sup>4</sup>Lloyd E. Stullken. 1984. Personal conversation. United States Geological Survey, Garden City, Kansas.

<sup>5</sup>Groeneveld, D.P. and T.E. Griepentrog. 1982. Integrating environment with groundwater extraction. ASCE Preprint 82-026. Paper presented at the ASCE Annual Convention, April 26-30 at Las Vegas, Nevada.

---

<sup>1</sup>Paper presented at the Symposium on Riparian Ecosystems and Their Management, Tucson, Arizona, April 16-18, 1985.

<sup>2</sup>David P. Groeneveld, Plant Ecologist and Consultant, Bishop, California.  
Thomas E. Griepentrog, P.E.,  
Geohydrologist and Consultant, Montrose, Colorado.



The basin receives from 14 to 40 inches of annual precipitation mostly in the January-April period. Seventeen inches per year is the approximate regional average. The Carmel River discharge averages just under 100 c.f.s. on a long-term basis but measured flow has been as high as 8,620 c.f.s. in 1969 to zero flow during late summer of drier years.

#### DOMINANT VEGETATION

Low water retention of the floodplain soils restricts plants in the riparian zone to either xeric or phreatophytic habit due to the long summer dry period. The water loving species are maintained by shallow groundwater and surface water flows from the recharge received during winter and spring precipitation.

Trees dominate the mature riparian forest along the Carmel River. Although the composition of the riparian forest varies highly with location, within the more pristine stands it is composed of approximately 60 percent red willow (*Salix laevigata*), black cottonwood (*Populus trichocarpa*), 30 percent and 10 percent California sycamore (*Platanus racemosa*) and white alder (*Alnus rhombifolia*) combined.

Two distinct zones of riparian vegetation cover and health can be viewed along the lower twelve miles of the Carmel River. The lowermost four miles inland from the ocean is overgrown with nearly continuous red willow crowns where encroachment has narrowed the riparian forest to a strip lining the riverbank.

The next linear eight miles upstream have markedly reduced riparian cover (Fig. 1). The bank between clumps of the remaining riparian tree species is sparsely vegetated with weedy perennials, annual grasses and xeric shrub species. The denuded riverbanks here show conspicuous erosion. A 2.2 mile portion of this zone was chosen for detailed study of vegetation history.

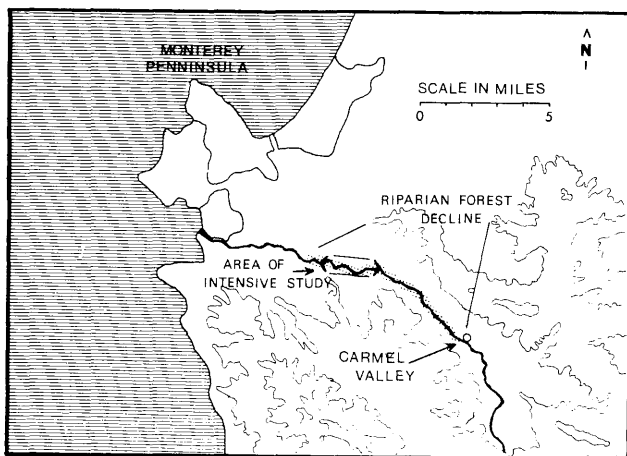

Figure 1.--The lower Carmel River Region. Contour intervals are 1,000 feet.

#### Riparian Forest Changes Through Time

The two zones of riparian cover observed during field survey is strikingly evident on recent (1980) air photographs. By contrast, an analysis of pre-1960 air photographs indicated that the river supported a continuous cover of riparian forest. A series of six photograph sets of suitable quality were assembled to document the change of riparian vegetation through time; black and white United States Soil Conservation Service (1956, 1966, 1971 and 1974), United States Forest Service color (1978) and color infrared obtained from a private source (1980).

Plant cover observed on the air photographs were mapped onto a base prepared from the U.S.G.S. Seaside 7.5 minute quadrangle enlarged to 1:6,000. A zoom transfer scope outfitted with optics for correcting distortion enabled keying the coartypes into correct position and scale by referring map features to the ground images on the air photographs.

Vegetation mapping categories were kept simple to accommodate the range in detail observable on the widely different scale, contrast and quality of each photo set. Three coartype categories were keyed to layers of vegetation greater and less than ten feet in height, and unvegetated river alluvium. Canopy height was inferred by cross-referencing eave height on one story houses adjacent to the floodplain using an eight power mirror stereoscope to accentuate three dimensional depth of field. The streambed was differentiated from the annual grass meadow cover by texture and tone on the black and white film and by color on the color infrared and color photo sets.

The mature riparian trees are all taller than ten feet. Therefore, within the floodplain, the map category for tree cover accurately represents the riparian forest. Field checking eliminated trees that were planted and maintained by man.

The time series of maps shown on Figure 2 documents the thinning of the riparian forest readily observable on the photographs. Loss of riparian forest cover over the 24 year period is visible initially in the upstream section toward the right of the 1966 map. Gradually the forest cover lessens in the remaining sections of the study area until, by 1978, the riparian forest cover is discontinuous with much of the remaining vegetation surviving at some distance from the channel margins. In 1980, the riparian cover is reduced even further and the river channel has widened dramatically, particularly in the downstream sections.

Following further analysis, tree pathogens, fire and encroachment by man were ruled out as possible causal agents for the decline of the riparian forest. The decrease of riparian trees coincides with the gradual development of the Monterey Peninsula and the wells to export groundwater to meet the increasing demand. The well field extracts water from the river alluvium within the zone of vegetation impact noted both in the field and on the air photographs. The operating wells in the vegetation study area are indicated on Figure 2 in the sequence of development and use.

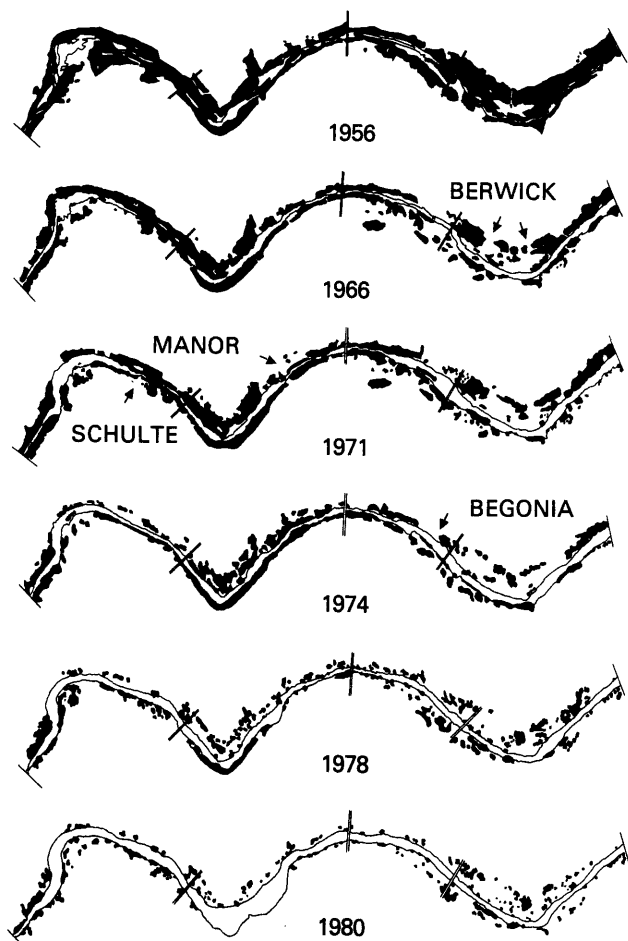

Figure 2.--Time series maps of the study area with the riparian forest indicated. The study area is divided into 4 sections according to the location of high capacity export wells.

#### GROUNDWATER HYDROLOGY AND PLANT RESPONSES

A water budget assessment of the study area was made for the study area which included quantifying gains and losses to the system. Recharge to the study area comes directly from precipitation on the valley floor, runoff from the bordering valley sides and tributaries, deep percolation from surface irrigation and septic systems, agriculture return flow, down-valley groundwater flow through the alluvium and in the river channel. Disposition occurs via evaporation, transpiration, consumptive domestic uses, outflow of the Carmel River, downgradient drainage through the alluvial aquifer and from pumping for export.

Based upon conservative estimates, the water budget indicated that local consumptive use as an annual total was only about eight percent of the aquifer capacity and was spread throughout the year. By contrast, pumping for export was seen to demand a large proportion of the aquifer capacity. The down valley groundwater flow and infiltration from the channel flow, when available, tend to recharge the basin at a rate slower than pump extractions. This recharge somewhat buffers the draw-

down in the system so the drawdown from pumping tends to be greatest during late summer and fall. The five foot isocontour of groundwater drawdown from the spring high levels to an October low are plotted on Figure 3. These zones of influence encircle the export wells and correspond well with the zones of riparian vegetation decline on Figure 2.

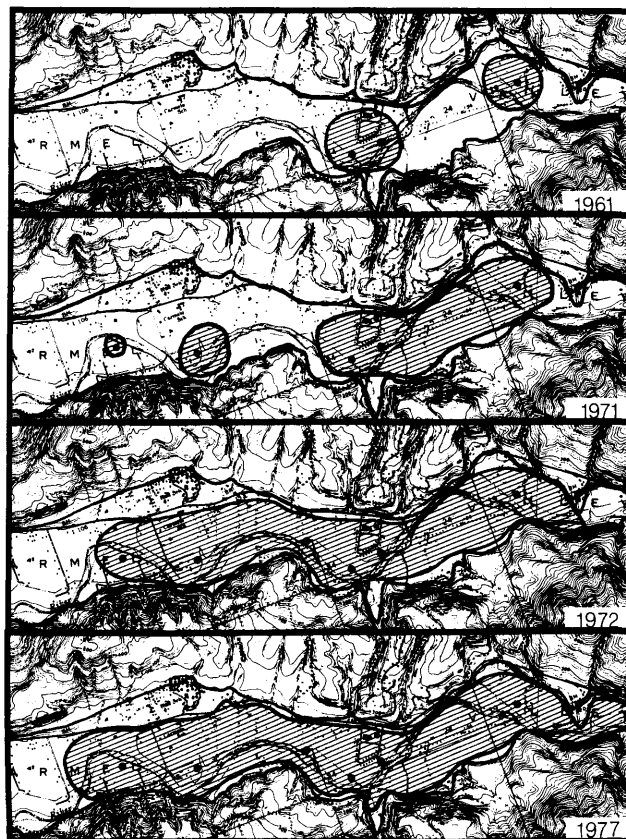

Figure 3.--Zones of influence in October for four select years. The 5 foot isocontour of drawdown from the spring high is the zone boundary. The limits of the valley fill are indicated.

#### Riparian Water Requirements

Young and Blaney (1942) measured water consumption by willow in Santa Ana, California to be about 56 inches during the period from June through September. It is reasonable to assume that willow and other riparian vegetation within the slightly more humid Carmel Valley would transpire at least 30 inches per year through the same period. The average June through September precipitation is less than one inch<sup>6</sup> confirming that willows and other riparian vegetation are groundwater dependent.

<sup>6</sup>United States Weather Bureau Records. Carmel Valley, California.

## Tree Roots and Declining Water Tables

An implied question is posed by the hydrologic analysis: can the roots of riparian phreatophytes follow a retreating water table? To answer this question, soil pits were dug around the base of red willow (*S. laevigata*) in the study area during late summer. The roots of the red willow were found only to a depth delimiting the bed elevation of the adjacent dry channel. These roots were quite fragile and spongy due to the presence of cortical air spaces.

Cortical air spaces called aerenchyma, are characteristic of many wetland species. The air spaces arise by lysis within parenchymal tissue and have been found to improve oxygenation to root tips. (Coutts and Armstrong, 1978), (Kawase and Whitmoyer, 1980). This morphologic adaptation, however, probably reduces the penetrating power of the root tips because the induced sponginess reduces both the axial rigidity and radial anchorage cited by Barley and Greacen (1967) as necessary for efficient soil penetration by roots.

Black cottonwood roots in the vicinity of the willow test pits were undercut and washed free from the bank. These roots showed the same pattern of truncation at about the elevation of the adjacent channel noted for the red willow.

The reason that the observed willow and cottonwood root systems had not adapted to follow the rapid water table retreat may be due to soils of the floodplain. The floodplain substrate is very coarse and retains only small amounts of water after drainage. This restricts contact of matrix water films after complete drainage from pumping. The gradient necessary for inducing deeper rooting is therefore probably broken during rapid water table decline. Poplars, of which the black cottonwood is a member, have been observed by Hoffman (1966, as cited by Kramer and Kozlowski, 1979) to achieve five centimeters per day growth rates. Such rates are, of course, moderated by soil impedance and the timing required for redifferentiating root buds from aerenchymatous tissue to roots more suited for exploring the soil.

## Sequence of Events

Each of the covertype maps shown in Fig. 2 was fitted with a clear template delimiting a riparian corridor along the river. The study area was divided into sections conforming to the location of high capacity wells designated from down to upstream; Schulte, Manor, Berwick and Begonia. A dot planimeter was used to obtain three replications of the area of the riparian forest and unvegetated river alluvium covertypes. These values were averaged to yield data documenting the temporal relationship of riparian vegetation decline, increased channel erosion and pumping<sup>7</sup> plotted on Figure 4.

<sup>7</sup>Pump production records obtained from the California-American Water Company.

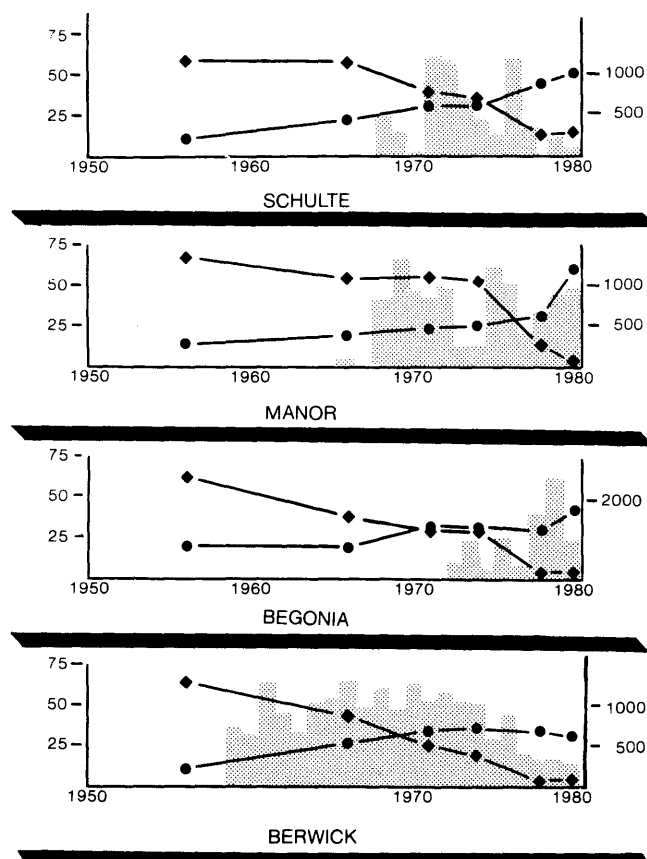

Figure 4.--Percent cover by riparian forest (diamonds) and unvegetated river channel (circles) versus pumping in acre feet from wells in each section.

## PUMPING, VEGETATION DECLINE AND CHANNEL EROSION

Kondolf (1983) analyzed the geomorphology of the Carmel River system to determine the cause and effect relationship for the massive streambank erosion by measuring such parameters as river sinuosity, bed load, gradient and channel configuration in relation to influencing factors such as historic fires in the catchment basin, streambed mining, construction of dams upstream and the timing and rate of river flows. Kondolf concluded that although "some bank erosion is natural in most fluvial systems ... natural, random process is inadequate to explain the massive bank erosion experienced along the Carmel River in 1978. This erosion must be regarded as out of the ordinary in that it occurred during years unremarkable for high flows." After lengthy examination of the physical system, Kondolf concluded that the bank erosion was coupled with groundwater pumping through dieoff of riparian vegetation.

Streambank stabilization by vegetation results from the reinforcing nature of the plant roots. This mechanism is documented in the literature and though limited discussion will be made here, the reader is urged to see Smith (1976), Seibert (1968), Ziemer (1981) and Gray and Leiser (1982) for more background. In summary, streambank stabilization by roots results from increased tensile and shear

strength of the bank soil mass and through armor-  
ing provided by roots as they wash free from the  
substrate. These mechanisms were obviously lack-  
ing for the readily erodable bank material within  
the impact area.

The most severe erosion of streambanks on the  
Carmel River occurred within the study area. A  
time series of photographs taken from the Schulte  
Road Bridge looking upstream document the process  
of bank erosion following loss of stabilizing  
plant growth (Figures 5, 6 and 7). The photo  
point can be located on the maps of Figure 2 as  
the double line between the Schulte and Manor sec-  
tions of the river. The 1976 photograph was taken  
in late fall 1976 and shows dead cottonwoods and  
willows lining the approximately 60 foot wide  
channel. The 1978 photograph captures the same  
scene following spring high water flows which  
equate to a ten year recurrence interval (Kondolf,  
1983). Note that the toe of the bank has been  
eroded back about 30 feet from the channel margin  
position visible in 1976. According to photogram-  
metry of the 1978 air photograph set, the erosion  
due to this flow resulted in an ultimate channel  
width of about 150 feet within the field of view  
of the photograph. A photograph following spring  
high water flows in 1982 illustrates the same  
scene but with aggradation of the margins to form  
a channel over 400 feet wide. This erosion  
occurred following two five year recurrence inter-  
val flows in the intervening four year period.



<sup>8</sup>Ed Lee. 1982. Photographs of the Carmel  
River. Board of Directors, Monterey Peninsula  
Water Management District.



Figures 5, 6 and 7.--1976<sup>8</sup>, 1978<sup>8</sup> and 1982 photo-  
graphs of the Carmel River Channel. The  
arrow indicates a reference point.

#### LITERATURE CITED

- Barley, K.P., and E.L. Greacen. 1967. Mechanical  
resistance as a soil factor influencing the  
growth of roots and underground shoots.  
*Advances in Agronomy*, 19:1-43.
- Coutts, M. P. and W. Armstrong. 1978. Role of  
oxygen transport in the tolerance of trees  
to waterlogging. *In* M. G. R. Cannell and  
F. T. Last (eds.) *Tree physiology and yield  
improvement*. Academic Press, New York.
- Gray, D.H. and A. Leiser. 1982. Biotechnical  
slope protection and erosion control. Van  
Nostrand Reinhold, N.Y. 271 pp.
- Judd, B. Ira, James M. Laughlin, Herbert R.  
Guenther and Royal Handegarde. 1971. The  
lethal decline of mesquite on the Casa Grande  
National Monument. *Great Basin Naturalist*.  
31:153-159.
- Kawase, Makoto and Robert E. Whitmoyer. 1980.  
Aerenchyma development in waterlogged plants.  
*Amer. J. Bot.* 67:18-22.
- Kondolf, C.M. 1982. Recent channel instability  
and historic channel changes of the Carmel  
River, Monterey County, California. M.S.  
Thesis. University of California at Santa  
Cruz. 112 pp.
- Kramer, P.J., and T.T. Kozlowski. 1979. Physio-  
logy of woody plants. Academic Press, New  
York, N.Y. 809 pp.
- Seibert, P. 1968. Importance of natural vegeta-  
tion for the protection of the banks of  
streams, rivers and canals. *In* *Freshwater  
Studies, Nature and Environmental Series*.  
Council of Europe, Strassbourg. 3:35-64.
- Smith, D.G. 1976. Effect of vegetation on  
anastomosed channels of a glacier meltwater  
river. *GSA Bull.* 87: 857-860.
- Young, Arthur A. and Blaney, Harry F. 1942.  
Use of water by native vegetation. *Calif.*  
*Dep. Public Works Div. Water Resour.* 50:  
150 pp.
- Ziemer, R.R. 1981. Roots and stability of  
forested slopes. *In* *Erosion and sediment  
transport in Pacific Rim steeplands*. IAHS  
Pub. No. 132: 343-361.

# Physical Characteristics and Pedogenesis of Soils in Riparian Habitats Along the Upper Gila River Basin<sup>1</sup>

John H. Brock<sup>2</sup>

---

Abstract.--Knowledge of soils in southwest riparian habitats is minimal. Soil profiles in the riparian zone on the Gila and San Francisco Rivers were studied. The soils that support trees can be classified as Torrifuvents or on the more stable sites as Haplustolls. Coarse textures and low water holding capacity are dominant characteristics.

---

## INTRODUCTION

Riparian communities of the southwest are dominated by tall broadleaf woody plants which affect the microclimates of adjacent aquatic habitats while providing cover, nesting sites and food items for many desert animals. Since the early 1800's riparian habitats along river systems of the arid southwest have undergone significant biological, physical and hydrologic changes, primarily from increased human activity (Carothers 1977). Although riparian areas represent less than four percent of the lands in the western United States, they are of great importance in arid land ecosystem functions, particularly as wildlife habitats. The importance of riparian communities as wildlife habitat has been well described in the literature (Todd 1972, and Carothers 1977).

Study of riparian zones has previously focused on the organisms that occupy the narrow habitats. As research intensified, it became evident that little was known about the soil supporting the vegetation that characterizes the riparian zone. Very limited literature exists on riparian soils except that reported by Martin and Fletcher (1943) and recently completed work by Medina (1985). This paper will present information concerning soils in the riparian habitat of the upper Gila River Basin. Classification of the soil, its physical characteristics and its pedogenesis will be discussed.

---

<sup>1</sup> Paper presented at the Symposium on Riparian Ecosystems and their Management: Reconciling Conflict Uses. [Tucson, Arizona, April 16-18, 1985]

<sup>2</sup> John H. Brock is Associate Professor of Agriculture, Arizona State University, Tempe, Arizona.

## RELATED LITERATURE

Riparian communities fit in the wetland classification under riverine systems (Cowardin 1982). One attribute of this wetland system, according to a Fish and Wildlife Service definition, is "the substrate is nonsoil and is saturated with water or covered by shallow water at some time during the growing season" (Cowardin 1982). The "nonsoil" of such riverine systems would be placed into the order Entisols since soil horization does not exist in streambed materials and because pedogenetic processes are slower than transport activities (Soil Survey Staff 1975).

Soils of arid and semi-arid regions typically exhibit limited pedogenesis, especially along drainages. Western (1972) advocated that soil texture, degree of depositional stratification and effective soil depth be given major consideration for describing such soils. Using the depositional approach, defining vertical variability of texture as closely as possible would be accentuated since stratification may alter water movement and root penetration and emerge as a dominant soil characteristic. Under the soil classification system used by Western (1972) these type of soils would be placed into the sedosols category.

Very limited literature exists for the southwest riparian zone soils. Martin and Fletcher (1943) described soil great groups that included drainages on Mount Graham in southeastern Arizona but not soils specifically within the drainages. The most detailed work available on riparian soils in the southwest was recently completed from research initiated in 1981 (Medina 1985). The riparian soils were on upland watersheds near Fort Bayard in western New Mexico. The taxonomic subgroup units identified for those drainages included: Mollic Ustifluvents, Aquic Ustifluvents, Aquic

Haplustolls and Cumulic Haplustolls (Medina 1985).

Soils along the drainages of the upper Gila River Basin (Eastern Arizona and Western New Mexico) that support mature woody riparian species were surveyed as a complex of Ellicott and Paymasters series (USDA Soil Survey 1983). These soils at the subgroup level are Ustic Torrifluvents (Ellicott) and Cumulic Haplustolls (Paymaster). Both soils are subject to summer flooding with the flood event being rarer for the Haplustolls. The soil material in the most active part of the streambed was designated in the soil survey report as riverwash.

#### METHODS

The study area included six research sites. Two were on the San Francisco River in Eastern Arizona and four were on the Gila River in Western New Mexico. The San Francisco River sites were 8 and 24 km, respectively, upstream (northeast) from Clifton, Arizona. The four New Mexico sites were located from south to north along the Gila river as follows: (a) 0.8 km north of the bridge near Red Rock, (b) 12 km south of U.S. Highway 180 near the U.S. Forest Service Bird Management area, (c) 11 km north of the towns of Cliff and Gila near Mogollon Creek and (d) 19 km upstream from Cliff and Gila in the vicinity of Turkey Creek. This study area also included a well defined mesquite bosque.

The flood plains are mixed alluvium derived from granite, rhyolite and conglomerate (USDA Soil Survey, 1983). Average annual precipitation is approximately 35 cm and the growing season is 150 to 180 days. Mean annual soil temperature and air temperature are approximately the same at 14°C (USDA Soil Survey 1983). Slopes range from zero to three percent and elevation ranges from 1200 to 1900 m.

At each of the six sites a soil profile in a stand of mature trees, including the mesquite bosque, was examined. The exposed profiles were approximately one meter in width to a depth of two meters. The profiles were separated into soil layers based on color differences or appreciable changes in texture or structure. The thickness of the soil layers was measured and duplicate samples from each layer were returned to the laboratory for further analysis as needed to classify soils.

Normally, to estimate soil texture, soils are sieved to 2 mm to determine sand, silt and clay content. However, riparian soils may contain a large volume of coarse fragments and the standard procedure would not give an accurate representation of texture. Alexander (1981) described a technique to estimate the coarse soil fraction that employs a combination of visual estimates of volumes and weighing.

Coarse materials were sorted to three size classes (rock > 7.5 cm, cobbles from 7.5 cm to 2 cm and gravel from 2.0 cm to 2 mm) (fig. 1). The larger two classes were visually estimated from a known total volume. Gravel content was determined by sieving and weighing. The material that passed the 2 mm sieve was separated into sand, silt and clay sized particles in the laboratory using the hydrometer method.

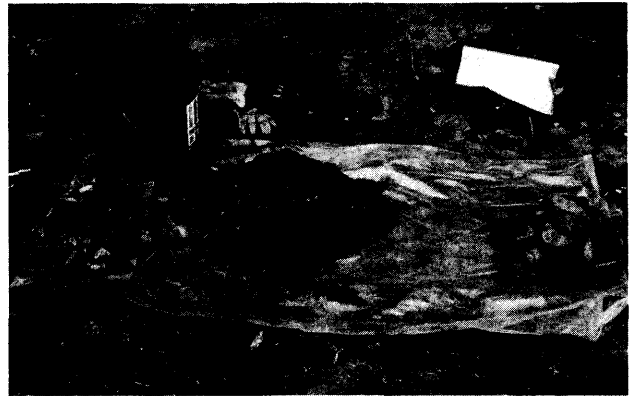

Figure 1.--Coarse fragments are common in riparian soils. Sample is of riverwash material near Red Rock, New Mexico.

Since coarse soils rapidly transport water, a water movement laboratory study for soils of the riparian habitat was conducted. Large graduated cylinders (1000 ml) were filled with 35 cm of soil material leaving approximately 5 cm of space for the addition of water. Three cylinders were filled with fine sands (less than 0.42 mm in size), three with coarse sands (1 to 2 mm in size) and three with coarse unsieved riverwash material. Two hundred milliliters of water was added to each cylinder and the rate of water movement over thirty minutes was measured by following the wetted front.

Water movement rates and water storage capacity in coarse soils is an important factor to relate availability of water to riparian plants. Water retention capacity was determined for the mature forest and riverwash soil materials. The saturation point was found by wetting samples to super saturation with the superfluous water drained by gravity. Soil-water retention was also determined at moisture tension levels of -0.03 (field capacity), -0.1, -0.25, -0.75 and -1.5 (wilting point) MPa of tension using a pressure plate apparatus. Percent soil-water retention capacity was determined gravimetrically.

#### RESULTS AND DISCUSSION

Three soils were identified in the riparian zone. Two soils were located in the proximity of perennial woody vegetation and the other was the raw material of the flood plain. Of the

seven soil profiles examined in the vicinity of mature woody perennials, four were classified to the greatgroup Torrifuvents and three were placed in the Haplustolls great group. The third soil was riverwash.

#### Soil Profile Descriptions

The Torrifuvent soil was further classified to the Ustic subgroup. A profile description of the Ustic Torrifuvents from the site located 11 km upstream from Cliff and Gila, New Mexico is contained in table 1. The deep, well-drained Torrifuvents have a sandy surface that averaged 42.5 cm in depth. The number of soil strata present was directly related to depositional patterns as may be expected from Western's (1972) paper and ranged from three to seven. The separation of the layers was based primarily on textural differences resulting from the energy of water that had transported the alluvial material. Thin lenses of fine textured material such as loams or silt loams were present in some of the pedons. The mean soil depth of the Torrifuvents was 174 cm.

The placement of the soils into the Ustic Torrifuvents subgroup agrees well with the soil survey of western Grant County, New Mexico (USDA Soil Survey 1983). The soils are in the great group Torrifuvents because they have a mean annual soil temperature of approximately 14°C but may also lack water within the top 50 cm for more than 90 consecutive days during the year. They are in the subgroup Ustic because they do have moisture available for plant growth during favorable growth periods, primarily in the spring and early summer. The Haplustolls were classified to the subgroup Fluventic. A typical pedon of a Fluventic Haplustoll is given in table 2 from the site approximately 19 kilometers above the towns of Cliff and Gila. The profile description is for the deep, well drained soils that form in more stable alluvium. The Haplustolls surface had a mean depth of 30 cm.

Unlike the soil survey information that placed the Haplustolls along the water courses in the Cumulic subgroup, the Haplustolls examined in this study did not have a thick enough epipedon (more than 50 cm) to be placed in that category. Alluvial deposition was evident in the surface soil material. As a result, the subgroup classification for the Haplustolls along these reaches of riparian habitats was the Fluventic extragrade.

The third soil material identified was confined to the most active part of the flood plain. Unlike the Ustic Torrifuvents and the Fluventic Haplustolls it lacked any signs of pedogenesis. The material is unconsolidated, very coarse and contains raw parent materials best referred to as riverwash. While riverwash may be considered by some to be only soil parent material, it is the seedbed for many of the

Table 1.--Profile description for a typical Ustic Torrifuvent on the upper Gila River Basin.

Horizon Designation	Description
C 1	0-66 cm, 10 YR 5/2 grayish brown (dry), fine sand, 10 YR 3/3 dark grayish brown (wet); single grain, loose; numerous roots, abrupt boundary, bedding planes.
C 2	66-142 cm, 10 YR 5/2 grayish brown (dry), cobbly sand, 10 YR 3/2 dark grayish brown (wet); single grain, loose.
C 3	142-167 cm, 10 YR 5/2 grayish brown (dry), coarse sand, 10 YR 3/2 dark grayish brown (wet). Abrupt boundary to rounded cobbles.

Table 2.--Profile description for a typical Fluventic Haplustoll on the upper Gila River Basin.

Horizon Designation	Description
A 1	0-53 cm, 10 YR 4/2 dark grayish brown (dry), very fine sand, 10 YR 2/2 very dark brown (wet); weak crumbly, very friable; worm casts in upper 5 cm, common macropores, few fine roots; weakly effervescent; gradual boundary.
C 1	53-107 cm, 10YR 5/2 grayish brown (dry), fine sandy loam, 10 YR 2/2 very dark brown (wet); weak subangular blocky, very friable; few laminar planes; coarse roots, neutral; gradual boundary.
C 2	107-213 cm, 10 YR 5/3 brown (dry), very fine sand, 10 YR 3/3 dark brown (wet); single grain, loose; coarse roots, few cobbles; abrupt contact with large rounded cobbles.

woody riparian species. These riparian seedbeds are at present commonly referred to as nursery bars by Brady et al. (1985) and Brock<sup>3</sup>. Riverwash would be in the suborder Fluvents. No profile description will be attempted in this paper since there was no stratification; however, the physical characteristics of the riverwash material will be presented.

#### Physical Characteristics of Riparian Soils

The coarse textural nature of soils in riparian areas provides unique qualities compared to finer soils. The riparian soils of the southwest are characterized by large fragments. The Haplustolls contained 10% coarse fragments (> 2mm) by weight, the Torrifuvents had 23% coarse material and the riverwash contained approximately 63%. Of the 63% coarse fragments in the riverwash, the portions of rocks, cobbles and gravel was 14, 16 and 33% respectively of the total volume. The remaining 37% of "fine" material in proportion to the

<sup>3</sup>Brock, J. H. 1984. Some autecological studies on regeneration and maintenance of selected riparian plant species. Unpublished report. Arizona State University, Division of Agriculture, Tempe, Arizona. 166 p.

whole soil was 33% fine sand, 2% silt and 2% clay. Riverwash material, excluding the coarse fragments, was 84% sand, 9% silt and 7% clay.

The coarse fragment content of the more developed soils ranged from 0 to 55 percent. The mean amount of coarse fragments was 16.5% for the Torrifuvents and Haplustolls. Textural analyses of the Torrifuvents and Haplustolls for the fine portion of the soils are presented in table 3. As might be expected, both soils have a dominance of sand in the surface. The evidence of pedogenesis in the Haplustoll is seen best by examining the texture of the subsurface soil. While sand was the dominant textural fraction, the increase in silt and clay in the Haplustolls was evident.

Water readily moves through coarse soils. The rapidity of water movement through the riparian soil material was greater than expected. Laboratory tests resulted in water movement rates of 0.9, 1.4 and 2.4 cm/minute for fine sand, coarse sands and cobbly sand materials, respectively. While riparian soils may rapidly absorb water they release water freely as well. Water retention percentages were determined for the Torrifuvents, Haplustolls and riverwash materials. Water holding capacity, at saturation, averaged 45.6% across all soils and was highest for Haplustolls and lowest in the riverwash (table 4). Water retention capacity decreased rapidly with even small increases in pressure that forces water from the soil matrix. Haplustolls maintained higher water holding capacity which corresponded to the finer textures. At higher tensions, water retention capacities were slightly lower in the riverwash material. At wilting point (-1.5 MPa), all soils had less than 7% water content.

Table 3.--Textural analyses for percent sand, silt and clay fractions Ustic Torrifuvents and Fluventic Haplustolls in surface and subsurface soils in the riparian zone of the upper Gila River Basin.

Textural Fraction (%)	Torrifuvents		Haplustolls	
	Surface	Subsurface	Surface	Subsurface
Sand	71.4	83.9	64.5	56.4
Silt	20.4	9.6	13.2	26.3
Clay	8.2	6.6	13.2	17.3

Table 4.--Water retention capacity for three riparian zone soils found in the Upper Gila River Basin.

Soil	Water Retention Capacity (%) at Water Tensions (-MPa)					
	Saturated	-0.03	-0.10	-0.25	-0.75	-1.5
Torrifuvents	48.3	15.7	9.5	7.4	6.8	6.5
Haplustolls	52.6	18.1	22.0 <sup>1</sup>	8.8	8.6	6.9
Riverwash	36.1	12.0	6.8	4.8	4.9	3.3

<sup>1</sup>Mean in -0.10 (MPa) column is significantly different at p = 0.05.

Soil longevity in active water courses, especially in the southwest, strongly influences the degree of pedogenesis. In the arid or semi-arid southwest, soils along water courses are more a result of geomorphology resulting from stream flows. This concept is supported by the paper of Western (1972) that dealt with soils of arid streams. Brady et al. (1985) described the development of riparian vegetation stands from initial establishment to maturity. Soils continue to deepen by aggradation and, with good vegetative protection, stabilize against the geomorphic forces.

The degree of pedogenesis in riparian soils is directly tied to stability of the substrate and magnitude of streamflow events. The dynamics of the soil forming-stability process in the Gila River Basin was demonstrated in October 1983. On the San Francisco River of the upper Gila basin, major areas of Ustic Torrifuvents were changed to riverwash by flooding (fig. 2). At this site, (24 km upstream from Clifton, Arizona) a depth of approximately 1.5 to 2.0 m of stable soil was moved from an area approximately 50 m in width. Flooding is the major factor influencing the nature of riparian soils in the southwest United States from a pedogenic viewpoint and is the force that largely determines their physical properties.

## CONCLUSION

Pedogenesis of soils in riparian habitats of the southwest, given adequate soil anchorage and aggradation of fine sediments is from the Entisols to the Mollisols order. The major factor determining the characteristics of the soils is the energy of streamflow. In general, riparian soils are geomorphically very young and coarsely textured. As a result, they readily transmit water and have a low water retention capacity. The primary management criteria of riparian soils as a growth media for woody riparian species would be a dependable soil-water supply.

## ACKNOWLEDGEMENTS

This research was conducted under an Interpersonal Agreement (IPA) with the author and the Rocky Mountain Forest and Range Experiment Station, USDA Forest Service. Funding was through the Bureau of Reclamation, USDI, Boulder City, Nevada. Chris Brock was instrumental in aiding initial soil profile sampling. Charmaine Tso and Julie Sturgeon deserve recognition for their assistance in collecting and summarizing water retention capacity data.





Figure 2.--Soil stability in a riparian habitat as influenced by high storm flow. Twenty-four kilometers upstream from Clifton, Arizona. Left photograph date is August 1983. Right photograph is of the same site in November 1983 following flooding.

#### LITERATURE CITED

- Alexander, E. B. 1981. Volume estimates of coarse fragments in soils: A combination of visual and weighing procedures. *Journal of Soil and Water Conservation*. 36:360-361.
- Brady, W. W., D. R. Patton, and J. Paxson. 1985. The development of southwestern riparian gallery forests. In *Symposium of Riparian Ecosystems and their Management: Reconciling Conflicting Uses*. [Tucson, Arizona, April 16-18, 1985].
- Carothers, S. W. 1977. Importance, preservation and management of riparian habitats: An Overview. In: *Importance, Preservation and Management of Riparian Habitat: A Symposium*. USDA Forest Service. General Technical Report. RM-43. p. 2-4.
- Cowardin, L. M. 1982. Wetlands and deepwater habitats: A new classification. *Journal of Soil and Water Conservation*. 37: 83-85.
- Martin, W. P., and J. E. Fletcher. 1943. Great soil groups on Mount Graham. University of Arizona Agricultural Experiment Station. Technical Bulletin. 99: 87-153.
- Medina, A. L. 1985. Riparian plant communities and soils of the Fort Baryard Watershed in Southwestern New Mexico (In Press). Southwest Association of Naturalists.
- Soil Survey Staff. 1975. *Soil Taxonomy*. U.S. Department of Agriculture. Soil Conservation Service. Agriculture Handbook No. 436. 754 p.
- Todd, R. L. 1972. Biological report on a marsh near Tuzigoot National Monument. Arizona Game and Fish Department Special Report w-53-23. 4p.
- U.S. Department of Agriculture 1983. Soil survey of Grant County, New Mexico, Central and Southern parts. U.S. Department of Agriculture, Soil Conservation Service and New Mexico Agricultural Experiment Station. 216 p.
- Western, S. 1972. The classification of arid zone soils. I. An approach to the classification of arid zone soils using depositional features. *Journal of Soil Science*. 23: 266-277.

# Interactions Between Streamside Vegetation and Stream Dynamics<sup>1</sup>

Burchard H. Heede<sup>2</sup>

---

**Abstract.**--Interrelationships between vegetation and hydrologic processes in riparian ecosystems must be considered by managers before they attempt to alter these natural systems. A 5-year experiment demonstrated that logs that fall across the channel from streamside forests dissipate flow energy, maintain channel stability, decrease bedload movement, and increase water quality.

---

## INTRODUCTION

We are beginning to understand more about natural systems, their dependency on other systems, and how these systems develop. This is an important step forward from simply evaluating static, present-day appearances. Our approaches must be based on the knowledge that natural systems are dynamic, and interact with each other. Long-term trends must be recognized if we are to evaluate the state of a system. The trends will demonstrate the brevity of a present condition, a transitional stage within evolution of a system, whether it is physical or biological.

This paper will focus on the inter-relationship between vegetation and stream systems by analyzing stream hydraulics--not only in terms of water, sediment, and geomorphology, as classically performed in the past, but also in terms of vegetation, specifically riparian and streamside ecosystems. In a 5-year study, I tested my hypothesis that log steps formed by downed trees take the place of gravel bars, and thereby reduce bedload movement. Log steps and gravel bars represent adjustments toward dynamic equilibrium. Significantly, the small mountain stream studied was never touched by management activity.

## PAST WORK

An aspect of southwestern riparian ecosystems that has received much recent attention is the influence of stream dynamics on

---

<sup>1</sup> Paper presented at the Symposium, Riparian Ecosystems and Their Management: Reconciling Conflicting Uses, [April 16-18, 1985, Tucson, Arizona].

<sup>2</sup> Burchard H. Heede is Research Hydrologist, USDA Forest Service, Arizona State University Campus, Tempe, Arizona.

the evolution of plant communities (Reichenbacher 1984). This recognition focused on the current morphology of streams, such as terraces, floodplains, and inside and outside banks of meanders (Irvine and West 1979, White 1979), but not on the long-term evolutionary processes of streams and riparian ecosystems and their interactions. The investigators, trained in the biological disciplines, did not concern themselves with the influences of plant communities on the physical system of streams. This aspect was pursued by hydrologists. Heede (1972 a,b) demonstrated that debris from streamside forests influenced the hydraulic geometry of two mountain streams by adding stream processes toward attainment of dynamic equilibrium. Swanson and Lienkaemper (1978) found the combination of forest clearcutting and large debris removal from western Oregon streams may lead to channel downcutting. Keller and Swanson (1979) stated that large organic debris may either cause or prevent channel erosion, thus influencing channel form and fluvial processes.

Examining present-day processes in the context of terrestrial evolution, Heede (in press) explained the interactions between natural systems. He showed that natural systems evolve slowly but consistently toward harmony within and between the systems.

## DYNAMIC EQUILIBRIUM WITHIN AND BETWEEN SYSTEMS

Due to the dynamic nature of systems, change is the rule and steady state does not exist. Changes can be caused by endogeneous or exogeneous developments. Endogeneous factors originate from within the systems. Examples are: channel instability caused by "normal" flow discharges that, by erosion over time, expose a weak geologic formation (soft shales, for example); and disruptions in a plant community caused by normal plant succession. On the other hand, exogeneous factors originate from events occurring outside the system--earthquakes, excessive rainfalls, or climate changes.

Endogeneous and exogeneous factors both can initiate adjustment processes directed at regaining or attaining dynamic equilibrium, also called quasi-equilibrium. This is not a true equilibrium condition, but one that allows rapid movement toward a new equilibrium after a disturbance. Severe disturbance of the system may lead to a total loss of equilibrium for a long time.

Adjustment processes not only aim at dynamic equilibrium within the system, but also between systems (Heede, in press). Thus, if one system is undergoing drastic changes, another interacting system will be affected and may also be forced to adjust. This has important implications for land management, as will be demonstrated in this report.

#### THE STUDY STREAM

West Willow Creek is a first-order stream located in a mixed conifer forest of the Arizona White Mountains at an elevation of about 2,700 m. Streamside vegetation consists of mixed conifers, but annual and perennial herbaceous vegetation occupies small flood plains, moist banks, and bars. The stream was classed quasi-ephemeral (Heede 1976) because it runs almost perennially. During the last 20 years of record, it had a dry channel only 2% of the time. ("Dryness" was defined as a period of more than 6 consecutive dry days).

Characteristic of many small streams of high mountain areas, West Willow Creek, with a

potential gradient of 6.2%, has an oversteepened profile. Large bed gravel and occasional bedrock protrusions prevent excessive erosion rates at higher discharges. Furthermore, trees and large branches falling across the channel are eventually incorporated into the hydraulic geometry by forming log steps, or small dams (fig. 1). At the waterfalls over the steps, flow energies are dissipated. Upstream from the steps, flow velocities are reduced due to tailwater formation. Once sediment accumulates above the log steps, the deposit gradients will be lower than those of the original bed, also reducing velocities.

When log steps fail due to rotting, or wash out during exceptional events, a large supply of downed timber is available to take their place, although not necessarily at the same location. This was shown in two streams about 4 km from West Willow Creek, where windfalls, about twice the number of failing log steps, were already suspended above the streambed (Heede, 1975).

Where trees are not available, transverse gravel bars form by bedload movement. These span the channel from bank to bank, and form small dams (fig. 2), much like the log steps. Gravel bars also reduce flow energy and accumulate sediment.

There is an inverse relationship between numbers of log steps and gravel bars (Heede 1976). With large timber supplies, fewer gravel bars form, because more log steps become established. Furthermore, there is a strong inverse relationship between the spacing of these



Figure 1.--Upstream view of a log step.

bed structures and the channel gradient; spacing decreases with increasing gradient. These relationships demonstrate a dynamic process toward adjustment of the channel slope gradient. The bed structures transform the potential (original) steep gradient into a stepped profile that dissipates energy and results in lower flow velocities.

The streamside forest not only supplies logs and limbs to channel and banks, but also large amounts of small organic material. This material plays an important role in soil development on banks and stable bars, demonstrated by invasion of herbaceous riparian communities that also aid channel stability. In contrast, the locations without plant cover had raw ground surfaces and exhibited surface erosion.

#### METHODS

All log steps were removed from West Willow Creek, amounting to an average of 17.1 steps per 100 m of channel. Logs were removed with great care to cause as little channel disturbance as possible. In addition to the steps, all forest debris was removed from channel, banks, and areas adjacent to the banks. This debris consisted mainly of windfalls suspended over the streambed, limbs, and failed log steps. Debris was removed periodically to assure a log-free channel. All debris was deposited outside the channel and away from the banks.

The amount of debris produced by the forest was indicated by a survey in a nearby stream,



Figure 2.--Upstream view of a gravel bar (between the two arrows).

surrounded by a comparable virgin forest at similar elevation. It yielded an average of 47 tons per hectare of forest debris larger than 7.5 cm in diameter. This is important for soil development and maintenance of high infiltration rates that decrease overland flow and erosion on channel banks. The sampling, which included the stream channel and strips of 4.5 m width adjacent to the channel banks, was based on established forest fuel inventory sampling procedures (Brown 1974).

Stream profile, locations of the former log steps, and shapes of channel cross sections, the latter spaced about 30 m apart, were measured in field surveys. Five years later, the surveys were repeated.

#### RESULTS

If my hypothesis was correct that gravel bars do not form where sufficient amounts of downed timber are available (Heede 1981), gravel bars must form if log steps are eliminated. Five years after log steps were eliminated, 74% of the steps were replaced by gravel bars. Relatively fast adjustment processes were at work.

One would expect severe changes to the channel in the vicinity of the removed steps because scarps were formed by the sediment deposits behind the former log steps. On the average, these scarps were 10 to 20 cm above the bed and thus created small waterfalls. Apparently, the small heights of the scarps were responsible that only 8% of all log removals led to knickpoints that advanced upstream. The remainder were stabilized by gravel bars or transformed into smooth gradient transitions. Gravel bars either took the place of the former log steps, providing a rock-armored waterfall, or sediment depositions upstream from the newly created gravel bars buried the scarps.

The temporary loss of gradient control by removal of the log steps, which made up 61% of all bed structures (gravel bars and log steps), led to an average 6.2% increase in channel cross section. This increase was caused by the advancing knickpoints that undercut the banks, destroyed the bank toes, causing bank sloughing and destruction of the herbaceous riparian vegetation.

Because the stream and forest systems were unmanaged before and during the study (except for log step removal), the adjustment processes toward gradient control were natural actions free from human influence.

#### DISCUSSION

The replacement of most removed log steps by gravel bars within a period of 5 years supports my hypothesis that fallen logs can prevent bar formations (Heede 1981). The importance of this lies in the fact that gravel bars are built by bedload movement. Logs, incorporated into the

hydraulic geometry, are channel controls that maintain the local base level given by the elevation of the log step crest. Thus excessive bedload movement is prevented. If the log step (control) rots or is eliminated, the accumulated sediment upstream from it may be set in motion. Due to sorting processes during sediment transport, larger gravels can create transverse bars by anchoring the individual rocks to each other and to the channel side slopes.

Since the bed material consists of many particle sizes, fine materials, held in place by larger ones, are also set in motion during bedload transport. The fines go into suspension and are carried into downstream reaches as suspended load. Bedload movement therefore not only impairs the stream reach where this movement takes place but also, by decreasing water quality, large segments of the stream system.

Because 39% of all structures were gravel bars, which were not disturbed, some controls were left in the stream after log step removal. Possibly, new gravel bars began to form rather quickly. Hence, damage to banks and herbaceous vegetation was not excessive, with a 6.2% change in the average channel cross section. However, bank sloughing not only removed the riparian vegetation and top soil, but also exposed the surfaces to raindrop impact and increased erosion. These processes proceeded until channel controls were reestablished by gravel bars, and sediment accumulated again, leading to bank toe protection and reinvasion of riparian vegetation.

Obviously, gravel of sufficiently large size (weight) must have been available for the formation of gravel bars. Otherwise, when log steps were removed, other adjustments would have taken place to offset the channel gradient increase. Adjustment processes can be ranked in terms of relative time and energy expenditures required for the attainment of a new dynamic equilibrium (Heede 1980). Ordered from small to large energy requirements, the processes involve changes in: bed form, bed armor, width, pattern (alignment), and longitudinal profile.

Typically, the study stream, having an oversteepened profile, originally adjusted its bed form (gravel bars and incorporation of log steps). If gravel is not available in sufficient size and/or volume, not only gravel bars but also armor may not form. In addition, narrow valley bottoms may preclude channel widening or alignment changes (meanders). Hence, the only available adjustment would be in longitudinal profile. Lowering of the channel gradient would require bed degradation, the process with the most energy expenditure.

Channel cutting (degradation) was reported by Swanson and Lienkaemper (1978) for streams draining the sandstone region of the California Coast Range (little gravel), after removal of large organic debris. Obviously, channel degradation has more severe impacts on riparian communities than does bedload movement and formation of new gravel bars.

## CONCLUSION

The experiment demonstrated that even the removal of dead and dying trees, much less the entire forest, bordering small mountain streams may initiate intense stream adjustment processes. These processes would continue until a new equilibrium within the stream and between stream and riparian ecosystem could be established. The primary impact would be increased bedload and suspended load transports, thereby causing decreased water quality and deterioration of riparian ecosystems. Because forest and stream systems interact, if we destroy one, the others will also be thrown out of dynamic equilibrium.

In contrast, maintenance of streamside forests in their natural condition, which includes dead and dying trees, will also maintain stream stability and healthy riparian ecosystems. Effective land management must recognize this interdependency.

## LITERATURE CITED

- Brown, James K. 1974. Handbook for inventorying downed woody material. USDA Forest Service General Technical Report INT-16, 24 p. Intermountain Forest and Range Experiment Station, Ogden, Utah.
- Heede, Burchard H. 1972a. Flow and channel characteristics of two high mountain streams. USDA Forest Service Research Paper RM-96, 12 p. Rocky Mountain Forest and Range Experiment Station, Fort Collins, Colo.
- Heede, Burchard H. 1972b. Influence of a forest on the hydraulic geometry of two mountain streams. *Water Resources Bulletin* 8(3):523-530.
- Heede, Burchard H. 1975. Mountain watersheds and dynamic equilibrium. p. 407-420. *Proceedings Watershed Symposium, ASCE, Irrigation and Drainage Division*, [Logan, Utah, August 11-13, 1975].
- Heede, Burchard H. 1976. Equilibrium condition and sediment transport in an ephemeral mountain stream. In: *Hydrology and Water Resources in Arizona and the Southwest. Proceedings 1976 Meetings Arizona Section, American Water Resources Association and Hydrology Section, Arizona Academy of Science* [Tucson, Arizona, April 29-May 1]. 6:97-102.
- Heede, Burchard H. 1981. Dynamics of selected mountain streams in the western United States of America. *Zeitschrift für Geomorphologie, N.F.* 25(1):17-32.
- Heede, Burchard H. (In press). The evolution of salmonid stream systems. *Proceedings, Wild Trout III*, [Yellowstone National Park, September 24-25, 1984]. Trout Unlimited, Denver, Colo.
- Irvine, F. R., and N. E. West. 1979. Riparian tree species distribution and succession along the lower Escalante River, Utah. *Southwest Naturalist* 24:331-346.
- Keller, Edward A., and Frederick J. Swanson. 1979. Effects of large organic material on

channel form and fluvial processes. *Earth Surface Processes and Landforms* 4:361-380.

Reichenbacher, Frank W. 1984. Ecology and evolution of southwestern riparian plant communities. *Desert Plants* 6(1):15-23.

Swanson, F. J., and G. W. Lienkaemper. 1978. Physical consequences of large organic

debris in Pacific Northwest streams. USDA Forest Service General Technical Report PNW-69, 12 p. Pacific Northwest Forest and Range Experiment Station, Portland, Ore.

White, P. S. 1979. Pattern, process, and natural disturbance in vegetation. *Botanical Review* 45:229-299.

# Emergency Measures for Streambank Stabilization: An Evaluation<sup>1</sup>

Ronald F. Schultze<sup>2</sup>  
and  
Glenn I. Wilcox<sup>3</sup>

---

Abstract,--Severe storms of 1978 through 1983 caused considerable damage to streams in California. The Soil Conservation Service used several mechanical and revegetation techniques to stabilize streambanks and re-establish riparian vegetation. Results of evaluations made on 29 projects are discussed and recommendations made to improve success.

---

## INTRODUCTION

After going through two of the driest years on record (1975-1976), California was hit several years in a row with severe storms. In 1978, 1979, 1980 and 1982, stream channels and debris basins were filled with debris and sediment, grade stabilization structures were damaged or washed out, highways and bridges were washed out, and severe erosion occurred on levees and streambanks.

To safeguard lives and property, the Soil Conservation Service (SCS) may be requested by sponsors to undertake emergency measures to retard runoff and reduce soil erosion and sedimentation. Emergency Watershed Protection funds were requested by the SCS on April 25, 1978 (see 7CFR624 for program administration rules). Through this program the Soil Conservation Service may provide technical and financial assistance to local sponsors whenever fire, flood, or other natural disaster causes serious damage in a watershed. In stream work, the project is designed to return the channel to its original capacity and to stabilize the bank. Therefore, most of the streambank stabilization projects are small and designed to protect only severely eroding spots. If unprotected, there could be damage to adjoining property or accumulation of sediment downstream. The sediment reduces stream channel capacity and can cause the stream to overflow its banks endangering life and property.

When the Soil Conservation Service began to work on the Emergency Watershed Protection program in 1978, SCS had never attempted such a program on such a large scale. The Soil Conservation Service examined 1,100 sites in 13 southern California counties. From

these, 316 projects qualified for assistance and were completed. Debris and sediment was removed from 131 miles of clogged stream channels and 38 debris basins, over 100 miles of streambanks and 325 miles of levees were repaired. One hundred sixty-three grade stabilization structures were repaired and 149 were constructed. Some of this work would not be eligible under current program criteria.

In 1979, 1980 and 1982, California was again hit by heavy winter storms. Fifty-five additional projects were completed in those years. From 1978 through 1982, a total of 371 projects were completed costing about \$62.6 million. Estimated benefits from the work amounted to \$1.5 billion. This includes value of land and improvements that had a potential of being damaged in the future from moderate storms.

In the 1978 program, very little revegetation work was done in southern California, but in San Luis Obispo and Monterey Counties, considerable revegetation was done. In the following years revegetation was nearly always included and it is now required on all stabilization projects. Many of the jobs were streambank stabilization projects, designed to stabilize banks or levees that were severely eroded and unstable as a result of flooding. Structural measures usually included bank shaping, gabions, concrete sacks and rock riprap or pipe and wire revetment. Revegetation work was done using various grasses, legumes, shrubs and trees. Numerous methods were used; many were successful and some were not so successful. Except for a couple of projects that included irrigation, maintenance was not required on any of the vegetative plantings.

Having a large number of projects in which revegetation was an important component provided an excellent opportunity to evaluate the emergency approach to riparian revegetation. Information from the evaluation is being used to improve specifications for future streambank stabilization and riparian revegetation work.

---

<sup>1</sup>Paper presented at the North American Riparian conference. (The University of Arizona, Tucson, April 15-19, 1985).

<sup>2</sup>Ronald F. Schultze is State Biologist, Soil Conservation Service, Davis, Calif., and

<sup>3</sup>Glenn I. Wilcox is Area Biologist, Soil Conservation Service, Salinas, Calif.

## EVALUATION

In 1983, an evaluation was conducted of revegetation work done on 29 projects in California's central coast area (SCS Area 5). Nine of the projects included seeding of only herbaceous vegetation. Twenty projects included herbaceous and woody vegetation. Plant species used in the revegetation work are listed in Table 1. Some projects had only one species planted, usually either barley or 'Blando' brome. One project included barley, three shrub and two tree species. The most common planting combination was 'Blando' brome and willow. Incidentally, 'Blando' brome and 'Zorro' annual fescue are two plants developed by the SCS Plant Materials Center at Lockford, California, for their superior performance in erosion control plantings.

Table 1. Plants used in revegetation work.

Common Name	Scientific Name	Number of Projects
Annual ryegrass	Lolium multiflorum	1
Barley	Hordeum vulgare	7
'Blando' brome	Bromus mollis	23
Creeping red fescue	Festuca rubra	1
'Zorro' annual fescue	Vulpia myuros	1
Rose clover	Trifolium hirtum	6
Mule fat	Baccharis viminea	1
Elderberry	Sambucus sp.	1
Willow	Salix spp.	18
Cottonwood	Populus fremontii	2
Saltcedar	Tamarix pentandra	1
Athel	Tamarix aphylla	1
Desert saltbush	Atriplex polycarpa	1
Fourwing saltbush	Atriplex canescens	1
Quailbush	Atriplex lentiformis	1

Of the 29 projects, 22 were one acre or less in size. The largest project was on about four miles of stream with 42 acres revegetated.

California's mediterranean climate produces high winter stream flows and very low summer flows; some creeks, however, have a perennial low flow, while others are intermittent with no flows in the summer. These flow characteristics influence selection of measures suitable for streambank stabilization work at a given site. In the areas selected for this evaluation there were four types of structural measures with which riparian revegetation was compatible. They included bank shaping only and bank shaping or levee construction coupled with other measures, such as pipe and wire revetments, rock filled gabion (wire) baskets and rock riprap. Concrete, concrete sacks and grouted rock are much less compatible with revegetation. The following is a brief description of revegetation methods used in the four types of projects.

Bank shaping only--Bank shaping without other structural measures was used in four projects. Two of the projects involved land slips that filled streams, and the two others involved removal of stream sediment. These projects were seeded with herbaceous plants, such as 'Blando' brome (6 lbs/ac) or barley (120 lbs/ac), fertilized with 16-20-0 fertilizer (500 lbs/ac), and

mulched with straw (2 tons/ac) after sediment and debris were removed from the streambed and the banks reshaped.

Pipe and wire revetment--Five projects used pipe and wire revetment. Pipe and wire revetment was usually placed parallel to the toe of a levee or shaped bank, with cross fences tied into the bank at intervals along the length of the project. Woody cuttings were usually planted at three feet centers along the toe of the bank behind the pipe and wire revetment. A few projects had additional cuttings planted on the streamside of the pipe and wire. Cuttings were usually inserted into soil using a steel bar or water jet. The water jet is a piece of steel pipe attached to a hose and water source. Water is controlled with a spigot at the top of the pipe. As the water is turned on, the pipe is pushed into the ground. The woody cutting is inserted alongside the water jet. As the jet is pulled out it washes soil around the cutting and eliminates air pockets. This method also waters the cutting as it is planted. The upper slopes of the banks and levees were usually seeded with herbaceous plants. In one project the upper slopes and top of levees were direct seeded with three species of Atriplex, each at 12 lbs/ac, in addition to barley.

Gabions--Gabions are wire baskets that are filled with rock. Two types of gabion structures were used. One type, used to protect vertical banks, consisted of baskets that were three feet wide, by three feet high and six feet long; the other type, for slope protection, consisted of 'blanket' baskets, one foot thick. Three projects were the vertical type. With these, vegetation could only be planted in the streambed outside the toe of the structure or above the structure where there was suitable soil, but little water. Six projects had the blanket type. A steel bar had to be pushed through the rock and into the soil before woody cuttings could be inserted. In the gabion blanket projects woody cuttings were usually planted with three or four rows (3 or 6 feet spacing) up the slope. An additional three or four rows were planted out from the gabion toe into the streambed, often in sandy material.

Rock riprap--Rock riprap was used on ten projects. Riprap is a layer of large rock (maximum diameter ranged from two feet to three feet) placed on a shaped slope (usually 2:1). One of two methods was used for planting woody cuttings. The first, and most difficult, was done after the rock was laid. A steel bar or water jet was inserted through the rock and into the soil. The cutting was then inserted through the rock. The second method was to plant cuttings in the shaped bank and then place rock on top of the cuttings. Where filter fabric was used under the rock, the cutting had to be inserted through the filter fabric. Two or three rows of cuttings were planted up the slope. One project had streambed material (mostly coarse sand) placed on top and in front of the rock riprap with willow cuttings planted in that material. The upper two rows were planted through the rock riprap. Except for these upper two rows all the other cuttings and sand were washed away by subsequent stream flows.



Since bank stabilization projects are to provide protection and stabilize severely eroding spots on streams, part of the evaluation was to determine if the structural and vegetative measures achieved this purpose. We were pleased to find that structural measures on 24 projects achieved their purpose with only minor damage even though there were severe storms following their installation. Five projects had significant damage caused by subsequent storms. Two of these projects were on land slips. These slips were treated by removing sediment and debris from the stream, shaping the lower banks and revegetating. They continued to be unstable. Three projects that were comprised of pipe and wire revetment and vegetated with herbaceous and woody vegetation were severely damaged by subsequent storms.

The vegetation on 14 projects became established and did a good job. Vegetation on eight projects had only fair establishment. Vegetation planted on seven projects had poor establishment or completely failed.

In most cases, herbaceous plantings performed as expected. In riparian revegetation work there are advantages to using barley. It provides good first-year cover for erosion control and, after it dies, provides some structural support for the soil. Barley does not reseed itself; in this more stable environment, therefore, native and naturalized plants can re-invade the site without competition from an introduced species.

In most areas, willows continue to be the plant of choice because they are usually locally available, easily established, provide more stability to the site than many other woody plants, and grow rapidly. Another plant that grows in a somewhat drier zone than willow and that has features similar to willow is mule fat. This plant was mistaken for willow and planted on a couple of sites. It has done well and can be found along many California streams.

The key element to most projects was stabilization of the site. Even though in some cases the plants failed, the sites were stabilized and provided suitable areas for revegetation by volunteer plants. In addition, where planted vegetation did well, especially willows, there was a buildup of sediment in the site and numerous invading plant species were becoming established.

From our evaluation there seemed to be several reasons for failure or poor success of plantings. Heavy rainfall and runoff before plants become established were probably the leading causes. Some plants such as willow were planted in unstable sandy streambed material and were washed out by heavy runoff before they had a chance to become established. Some plantings, including some willow and some cottonwood plantings, were too low in the streambed and were drowned out. Some willow cuttings were planted through gabion baskets perpendicular to stream flow and were broken off by high stream velocities. Some willow cuttings were planted under a layer of riprap that was too deep (probably greater than three feet) and they couldn't grow up through it. Woody plantings on some high droughty sites, such as levees built from riverbed materials (sand and gravel), did not get proper watering and dried up.

Eroding streambanks that are treated with pipe and wire revetments, gabion blankets or loose rock riprap will often naturally revegetate. Based on our evaluation, however, we strongly recommend that herbaceous and woody plantings be included with these kinds of structural measures. Plantings give the planner a choice of vegetation to achieve a desired purpose rather than relying on chance from natural revegetation. Revegetation is usually much more rapid with plantings. Wildlife and aesthetic values return to the site more rapidly.

#### RECOMMENDATIONS

The evaluation was done, primarily to determine if revegetation measures accomplished their purpose and the reasons for success or failure. Nearly all the projects provided adequate protection for severely eroding and unstable streambank sites. Once structural measures have been installed, there can be a natural influx of volunteer vegetation. However, the healing process, quality of restored wildlife habitat, and establishment of a more aesthetically pleasing site can be speeded up by revegetation work.

The following recommendations may be useful in designing future projects that combine structural and vegetative measures for streambank restoration:

1. Willow cuttings can best be planted under rock riprap that is three feet or less thick. They can be planted through filter fabric under the rock.
2. Don't plant woody cuttings where they will be submerged for prolonged periods.
3. Willow or similar cuttings can be planted through gabion blankets (1 foot thick) if at least two feet length of cutting is inserted into soil below the gabion blanket. Slope the cuttings slightly downstream.
4. Planting woody cuttings in pipe and wire revetment will work well.
5. Planting multiple rows of cuttings up the bank slope will allow those in most suitable locations to become established.
6. Don't plant into streambed beyond toe of the bank if streambed is unstable sand and gravel.
7. Some narrow channels may become choked with willow - but this would likely occur naturally - therefore, maintenance may be necessary on some sites to ensure desired stream capacity.
8. Locally available native woody plants, such as willows, mule fat and cottonwood, can usually be found that are suitable for the revegetation work.
9. Success of plantings in somewhat droughty sites can be significantly improved by irrigation through the first year.
10. The water jet method of planting woody cuttings seems to be the best method of installation.

# Renovation of a Plains State Stream — Physical Problem Solving<sup>1</sup>

Thomas J. Taylor<sup>2</sup>

John S. Barclay<sup>3</sup>

---

Abstract.--Quantifiable methods do not exist to assess hydraulic effects of stream renovation. To obtain such methods, channel obstructions were modeled from field data. These models were used to show changes in flood stages resulting from obstruction removal. This simulation may provide an approach for resource planners to predict flood water control without costly stream channelization.

---

## INTRODUCTION

Recent years have brought an alternative approach called renovation to flood control and stream improvement projects. Renovation typically includes removal of channel blockages, selective snagging, revegetation of eroding banks, and minor dredging. Renovation is designed to improve drainage capabilities at a fraction of the cost of other channel modification techniques while retaining the biological and aesthetic integrity of the stream system. This approach contrasts sharply with traditional stream modification philosophy because it seeks to minimize adverse impacts to fish and wildlife resources (Simpson et al. 1982), channel instabilities (Nunnally 1978), and high construction and maintenance costs (Council on Environmental Quality 1973, Nunnally and Keller 1979, McConnell et al. 1980).

Renovation planning and assessment of the effectiveness of hydraulic improvements often have been subjective (Herbkersman undated, McConnell and Zerfoss unpublished, Stream Renovation Guidelines Committee 1982). As a result, water resource planners and decision-makers may be finding renovation procedures difficult to apply and evaluate. Planners likely will opt for channelization (McConnell and Zerfoss unpublished).

We have developed a quantified procedure for planning renovation and for simulating the

---

<sup>1</sup>Paper presented at the North American Riparian Ecosystems Management Conference (Tucson, Arizona, April 16-18, 1985).

<sup>2</sup>Thomas J. Taylor is Graduate Research Assistant in the Department of Zoology, Oklahoma State University, Stillwater, Okla.

<sup>3</sup>John S. Barclay is Associate Professor in the Department of Zoology, Oklahoma State University, Stillwater, Okla.

effectiveness of the subsequent changes. It is hoped that these procedures will make renovation a more viable stream improvement approach.

## STUDY AREA

The study was conducted on the Deep Fork branch of the North Canadian River between river miles 159.33 and 180.96. The reach is located in eastern Lincoln County, Oklahoma and drains nearly half of the 272 sq km Deep Fork watershed.

Herbaceous communities on this portion of the watershed are transitional between the tallgrass and midgrass prairies (Penfound 1967). Post oak-blackjack oak predominate in the uplands (Rice and Penfound 1959) while bottomland forests are dominated by American elm (Ulmus americana), hackberry (Celtis occidentalis) and green ash (Fraxinus pennsylvanica) (Rice 1965). Agricultural development of the floodplain followed original dredging of the river (ca 1912-1923). Consequently, much--and in many locations all--of the riparian forest has been cleared for bermuda grass (Cynodon dactylon) pastures and crops that include wheat (Triticum sp.), alfalfa (Medicago sativa) and grain sorghum (Sorghum vulgare) (U.S. Fish and Wildlife Service 1979).

However, since 1940, agricultural activities in the floodplain have been hampered by floodplain inundation that currently lasts for 8 to 10 months annually. This inundation has resulted from the loss of channel capacity caused by watershed soil erosion, a lack of stream maintenance, and ongoing disposal of riparian timber into the channel. The study area centers around the largest logjam which blocks a continuous 1.6 km of the former channel. This logjam is part of the originally dredged reach now ineffective for almost 11 km. Circumventing this reach since the early 1980's is the current channel which has relocated to an old meander in agricultural land 300 m north.

Additional isolated blockages are located throughout the study area.

For purposes of this report, we have divided the channel into three main subreaches (Fig. 1) that include the following: 1) subreach I, rechannelized periodically from 1974 to the present; 2) subreach II, originally channelized (ca 1912) but currently obstructed, and circumvented by a meander channel; and 3) subreach III, also channelized around 1912 but currently unobstructed.

## METHODS

### Field Inspection

Air and ground reconnaissance were used to evaluate channel obstructions. Air reconnaissance followed the general techniques suggested by George Palmiter (Herbkersman undated). Present channel location, general obstruction classes (Stream Renovation Guidelines Committee 1982), the location of discrete channel blockages and their relative sizes were plotted on a series of U. S. Geological Survey (USGS) 7 1/2 minute quadrangle maps (scale = 1:24,000). A blockage was defined as any organic or inorganic materials which spanned or filled the channel. Blockages typically cause water to pond or be diverted into the floodplain (Stream Renovation Guidelines Committee 1982).

The most critical aspect of field observations was conducted on the ground. Low flows and extensive blockages forced foot travel to replace canoeing as the primary mode of ground inspection. To verify aerial observations, randomly selected sample sites (between two and three sites per river mile) on the Deep Fork were visited. Total sample sites equalled 40. At each site two 100 m transects were set up; one parallel and one perpendicular (i.e. a riparian transect) to the channel. Each transect was divided into 4-25 m segments and the following information was determined for each segment. A Manning's roughness coefficient,  $n$ , was assigned based on Chow (1959) and Barnes

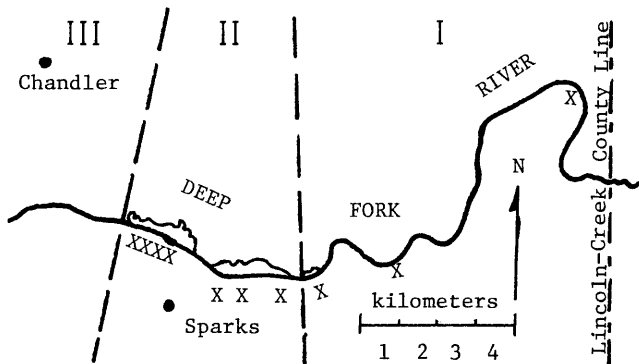

Figure 1.--Eastern Lincoln County Oklahoma showing subreach divisions for the Deep Fork River renovation study. Blocked (X) portions of the original dredge channel currently are bypassed by a new meander channel.

(1967). In the channel transect, bank slope was classified as less than 1, 1, 2, 3, 4, or greater than 4; depth was estimated to within 0.5 m; and width was measured with a 100 m tape. Each blockage was measured for its general dimensions which included length, width, and height.

### Modeling and Computer Simulation

Water surface profiles were determined for the Deep Fork River and floodplain within the study area. Profiles were simulated for pre-renovation or blocked conditions and post-renovation or unblocked conditions. The profiles then were compared. Development of profiles was facilitated by the HEC-2 computer software package made available through the U. S. Army Corps of Engineers (COE), Davis, California. The HEC-2 program computes water surface profiles iteratively by the standard step method for streams with slopes less than 1:10.

Baseline data of floodplain topography was collected from USGS photogrammetry of 1973 and adapted to include floodplain cross section data (COE Tulsa District, Tulsa, Oklahoma). The COE also provided the necessary flood discharge values associated with the local 2-, 5-, and 10-year frequency floods.

Considerable changes in stream conditions have occurred since 1973, when cross section data was compiled for the Deep Fork River. Buildup of channel debris, relocation of the main channel, and downstream channelization by private landowners resulted in the need for modifying a portion of the previous data. Data from 15 of the 19 original channel cross sections provided by the COE were modified based on field observations.

Channel dimensions and roughness coefficients determined in the field were derived for each 100 m transect by averaging the values assigned for each of the 4-25 m segments. The final values were replaced over appropriate COE data. Roughness coefficients resulting from the riparian transects were used to define overbank conditions and were assumed to represent both left and right overbanks. To adequately describe channel blockages, additional cross sections were developed by interpolation (Fig. 2) following procedures used by the COE (1982).

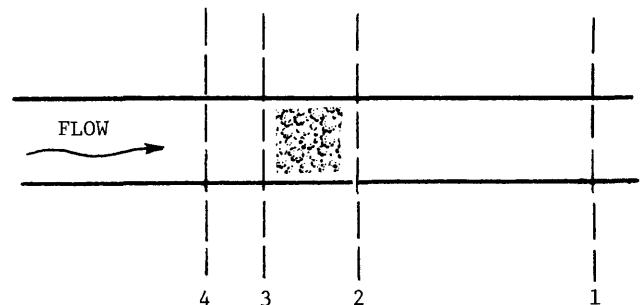

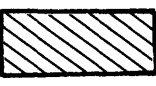
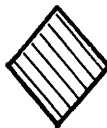



Figure 2.--An aerial view of the Deep Fork River demonstrating the placement of interpolated cross sections used to hydraulically define a channel blockage.

RESULTS

Table 1.--Values used for hydraulic coefficients associated with pre- and postrenovation channel obstruction conditions on the Deep Fork River, Lincoln County Oklahoma (Values derived from Chow 1959, U. S. Army Corps of Engineers 1982, and Shields and Nunnally 1984)

Blockage Model (aerial view)	Coefficients		
	Manning's Roughness (n) <sup>1</sup>	Contraction (K <sub>C</sub> )	Expansion (K <sub>e</sub> )
(Prerenovation)			
	.15	.4	.8
	.15	.4	.8
	.15	.3	.8
	.15	.2	.8
(Postrenovation)			
blockage removed	.04	.1 <sup>2</sup>	.3 <sup>2</sup>

<sup>1</sup>Manning's roughness coefficient assumes typical logjam surface roughness.

<sup>2</sup>These values represent averages used in U. S. Army Corps of Engineers water surface profile calculations.

For simplicity, blockages were assumed to be one of four general geometric shapes (table 1). Because ground sampling did not locate all blockages identified during the aerial reconnaissance, representative blockages were simulated at appropriate channel locations. Figure 3 illustrates a cross sectional view of a typical channel blockage. Values for roughness coefficients as well as contraction and expansion coefficients were assigned to reflect energy losses due to a blockage (table 1).

After the current floodplain and channel conditions were modeled, water surface profiles were generated for 2-, 5-, and 10-year frequency events. These profiles then were compared to those associated with the same events given that blockages were removed and all necessary coefficients were adjusted (table 1).

The amount of blockage in each subreach of the study varied substantially. The amount of debris in subreach I totalled 550 cu m as compared to 71133 cu m in subreach II. This debris comprised approximately 0.03 and 16 percent, respectively, of the total original channel volume in each subreach. The influence of recent drainage and clearing by private landowners in subreach I is evident from the relatively small amount of debris found there.

Changes in flood stages or water surface elevations (WSEL) between pre- and postrenovation conditions (table 2) indicated that the most notable WSEL changes were correlated with the most extensive blockage removal. Prerenovation versus postrenovation WSEL were projected to differ by tenths of a centimeter in subreach I and tenths of a meter in subreach II. This magnitude of difference was expected as increased area became available for water conveyance upon removal of the larger blockage in subreach II. However, overall WSEL changes were less than 0.2 m between pre- and postrenovation conditions. The limited effect of channel renovation observed is attributable to the fact that the old channel now lies within the wide overbank area and becomes relatively insignificant for calculation of total flood conveyance.

Field observations revealed that additional loss of capacity in the obstructed channel is related to considerable sediment deposition. Therefore, this condition would require sediment removal as well as removal of blockages in order to reestablish the former channel.

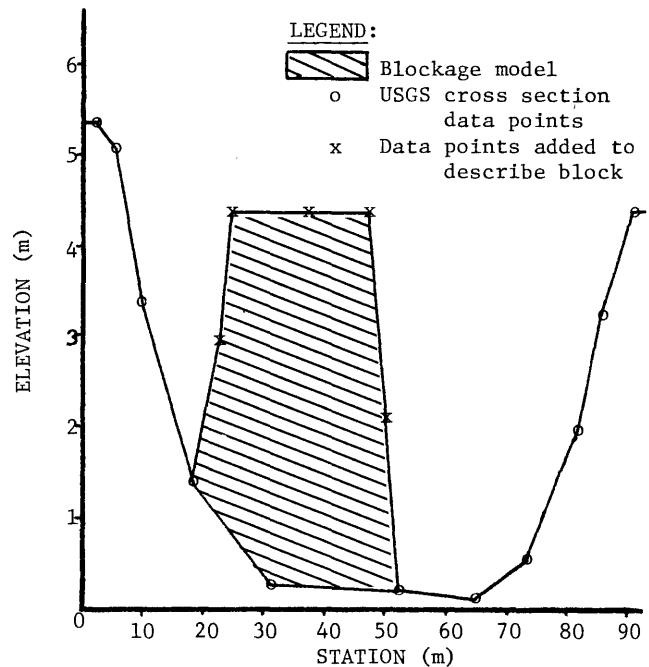

Figure 3.--A representative stream cross section at a blockage site in the Deep Fork River, Lincoln County Oklahoma.

Table 2.--Projected flood stage reductions resulting from simulated partial renovation (blockage removal) of the Deep Fork River channel, Lincoln County Oklahoma.

Average Frequency Storm	Subreach	Channel Condition	Water Surface Elevation (m)
2-year (261 m <sup>3</sup> /s)	I	Prerenovation	241.735
		Postrenovation (reduction:)	<u>241.729</u> .006
	II	Prerenovation	245.433
		Postrenovation (reduction:)	<u>245.385</u> .048
5-year (566 m <sup>3</sup> /s)	I	Prerenovation	242.365
		Postrenovation (reduction:)	<u>242.362</u> .003
	II	Prerenovation	246.317
		Postrenovation (reduction:)	<u>246.219</u> .098
10-year (793 m <sup>3</sup> /s)	I	Prerenovation	242.844
		Postrenovation (reduction:)	<u>242.841</u> .003
	II	Prerenovation	246.798
		Postrenovation (reduction:)	<u>246.679</u> .119

Renovation would increase the reductions in flood stage at higher discharge values, but the effect would become proportionally smaller between the 5- and 10-year frequency floods. The small 2-year frequency flood crest would be reduced by 4.8 cm in subreach II and would be confined almost within the existing channel banks. The increased flood stage of a 5-year frequency storm would be decreased by 9.8 cm. A 10-year flood would overtop the blockages, thus, suggesting that blockage removal is less effective as a flood stage reduction tool for larger storm events.

#### DISCUSSION

Field measurements and available baseline hydraulic information were shown to be useful for modeling of channel obstructions. Although significant flood stage reduction was not obtained from this simulation of a Deep Fork River renovation project, the methodology may have application in floodplains which contain major blockages in the primary channel.

The study demonstrated that quantification of the hydraulic effects of stream obstructions is possible. Such quantification once obtained would provide a clearer perception of flow problems and a better grasp of problem solving strategies. One possible application would be to determine which blockages when removed would provide the greatest immediate improvement in drainage and/or most likely would reduce flood hazards to life or property.

Simulation of renovation further indicated that channel improvement, in addition to blockage removal, probably would be necessary in this study area. In some locations, field data showed channel capacity reduced by more than 50% from sediment deposition and, in these areas, sediment removal would be required. Depending on objectives established in a renovation project, simulation of the sediment removal from those problem sites could indicate where limited resources could be expanded to obtain the greatest return.

Because portions of the Deep Fork River were originally straightened and deepened, it could be desirable to emulate the strategy being examined for the Kissimmee River in Florida. Backfilling of the channelized canal and restoration of the original meanders is being considered to overcome channel capacity problems (Pope 1977). The HEC-2 program would allow the planner to simulate the effects upon channel capacity resulting from adding original or even newly established meanders.

Models allow us to make predictions of the effects of channel improvements. Accurate prediction in designing stream renovation projects is critical to avoid further destruction of our natural waterways. Accurate prediction also is important to allow us to incorporate environmental considerations with planning for stream improvements and larger flood control channel projects (Pope 1977, McConnell 1979, Anonymous 1980, Shields and Palermo 1982, Shields and Nunnally 1984).

Our study was designed to determine if channel renovation, specifically blockage removal, could be substituted for channelization to help solve flood flow problems in the Deep Fork River. The study revealed that certain refinements would improve the predictability obtained from the model. Therefore, the following refinements are needed:

- 1) Determine the effect of using precise rather than representative field data for blockages when generating water surface profiles. Often there are social, financial or environmental constraints associated with each approach.
- 2) Determine whether more detailed and extensive field data or simpler average values for parameters such as roughness give significantly different outcomes in flood profile calculations.
- 3) Test the model for blockage removal on streams where blockages are a principal problem for drainage and stream flow.

#### CONCLUSION

This study was designed to allow us to model the effect of removing channel blockages on flood stage reduction. The model revealed that removal of blockages on the Deep Fork River resulted in only slightly reduced flood stages, and that additional renovation would be required to reestablish obstructed portions of the original channel. The methodology would appear to have

important application in streams where blockages are the main impediment to flood water drainage. Testing the blockage model discussed here on other stream data would prove useful.

#### ACKNOWLEDGMENTS

We wish to recognize the professional and financial support provided by the OSU University Center for Water Research and Department of Zoology as well as the Oklahoma Cooperative Fish and Wildlife Research Unit. Other individuals, too numerous to mention, contributed their thoughts, revisions and editing skills to this effort. Above all, the continual encouragement and patience shown by Mr. Donald Spurrier, P. E., of OSU Engineering Extension made this paper possible.

#### LITERATURE CITED

- Anonymous. 1980. Stream renovation: A necessary management practice for "208" programs. Wildlife Management Institute. (5 p.).
- Barnes, H. H. 1967. Roughness characteristics of natural channels. U. S. Geological Survey Water Supply Paper No. 1849. Washington, D. C.
- Chesemore, D. L. 1975. Ecology of fox and gray squirrels (*Sciurus niger* and *Sciurus carolinensis*) in Oklahoma. Ph.D. dissertation, Okla. State Univ., Stillwater. 348 p.
- Chow, Ven-Te. 1959. Open-channel hydraulics. McGraw-Hill, New York. 680 p.
- Council on Environmental Quality. 1973. Report on channel modifications, volume I, U. S. Gov. Printing Office, Washington, D. C. 394 p.
- Herbkersman, C. N. (n.d.) A guide to the George Palmiter river restoration techniques. Institute of Environmental Sciences, Miami University, Oxford, OH. 52 p.
- McConnell, C. A. and L. F. Zerfoss. Unpublished. Need for compromise in stream debris management. Paper presented to American Fisheries Society Annual Conference. Hilton Head, South Carolina, September 25, 1983. Available from: authors on request. 6+ p.
- Nunnally, N. R. 1978. Stream renovation: An alternative to channelization. Environmental Management 2(5):403-411.
- Nunnally, N. R. and E. Keller. 1979. Use of fluvial processes to minimize adverse effects of stream channelization. Rep. No. 144, Water Resour. Res. Inst., Univ. of North Carolina, Raleigh. 115 p.
- Penfound, W. T. 1967. A physiognomic classification of vegetation in coterminous United States. Bot. Rev. 33:289-326.
- Pope, M. 1977. Restoring the Kissimmee--when nature works best. Conservation News 42(11):3-5.
- Rice, E. L. 1965. Bottomland forests of north-central Oklahoma. Ecology 46(5):708-714.
- Rice, E. L. and W. T. Penfound. 1959. The upland forests of Oklahoma. Ecology 40(4):593-608.
- Shields, F. D., Jr. and M. R. Palermo. 1982. Assessment of environmental considerations in the design and construction of waterway projects. Tech. Rep. E-82-8, U. S. Army Engineer Waterways Experiment Station, Vicksburg, MS. 214 p.
- U. S. Army Corps of Engineers. 1982. HEC-2 water surface profiles user's manual. The Hydrologic Engineering Center, Davis, California. 39 p. with appendices.

# A Comparison of Riparian Area Ground Data with Large Scale Airphoto Interpretation<sup>1</sup>

Paul Cuplin<sup>2</sup>, William S. Platts<sup>3</sup>, Osborne Casey<sup>4</sup>, and Roy Masinton<sup>5</sup>

---

**Abstract:** A study site on Tabor Creek in northeast Nevada has been monitored by ground data collection each year since 1979. Airphotos of the study site were acquired in large scale (1:2,000 color) infrared 9- x 9-inch format during July 1984. Ground data and airphoto interpretation are compared.

---

## INTRODUCTION

Tabor Creek in Elko County, northwest Nevada, has been monitored both within and outside of fenced enclosures to show changes in riparian vegetation and stream characteristics that are related to various grazing systems that have been tested.

Tabor Creek is characterized by narrow riparian zones. Vegetation is a mesophytic type that includes shrubs such as willow, wild rose, and rabbit-brush; and grass-like sedges and rushes that are of limited value to livestock. Cattle prefer riparian vegetation to upland vegetation. This preference causes altered stream channels and vegetational changes (Platts and Nelson 1983).

Rest-rotation and other grazing systems are being tested. None of the systems tested were clearly effective in assisting in the rehabilitation of riparian vegetation. One strategy that is obviously useful is complete rest (Platts and Nelson 1983).

## GROUND DATA COLLECTION

Ground data collected were categorized into (1) geomorphic/aquatic, (2) riparian/streamside, and (3) hydrologic and biological.

Two variables, stream profile and stream gradient (items 17 and 18), can be measured by using a Kelsh plotter. All of the variables indicated with an asterisk (items 3, 10, 12, 13, 14, and 16) can be measured or interpreted with large scale 1:2,000 color infrared airphotos.

### Geomorphic/aquatic

1. Substrate materials
2. Substrate embeddedness
- \*3. Stream width and depth
4. Bank-stream contact water depth
5. Pool width, quality, and feature
6. Riffle width
7. Streambank angle
8. Streambank undercut
9. Fisheries environment quality rating
- \*10. Canopy cover
11. Light intensity

### Riparian/Streamside

- \*12. Streamside habitat type
- \*13. Streambank stability
- \*14. Overhanging vegetation
15. Vegetation use (ocular and herbage meter)
- \*16. Streambank alteration (natural and artificial)

---

<sup>1</sup>Paper presented at the Riparian Ecosystems and Their Management Symposium. [April 16-18, 1985, Tucson, Arizona].

<sup>2</sup>Paul Cuplin is a Fishery Biologist with the Bureau of Land Management, Denver, Colorado.

<sup>3</sup>William S. Platts is a Fishery Biologist with the U.S. Forest Service, Boise, Idaho.

<sup>4</sup>Osborne Casey is a Fishery Biologist with the Bureau of Land Management, Reno, Nevada.

<sup>5</sup>Roy Masinton is a Fishery Biologist with the Bureau of Land Management, Elko, Nevada.

Hydrologic and biological

17. Stream profile
18. Stream gradient
19. Stream velocity
20. Fish species composition, number, and biomass

In addition to the variables indicated above, ground cover of trees, shrubs, and herbaceous vegetation; bare soil; riparian area acreage; and structure can be determined.

CONCLUSIONS

Ground data collection and large scale CIR airphoto interpretation provide a combined data

base with more information than either method would provide separately.

Airphotos can be used for monitoring change. The technique is to visually compare baseline airphotos with airphotos taken about five years later. If obvious changes are apparent, sample areas can be delineated and compared. If significant changes have occurred, field data collection will help determine the cause of change.

LITERATURE CITED

- Platts, William S., and Rodger Loren Nelson. 1983. Livestock-Fishery interaction studies, Tabor Creek, Nevada. USDA Forest Service, Intermountain Forest and Range Experiment Station. 73 pp. Boise, Idaho.



# Riparian Area Inventory and Monitoring Using Large Scale Color Infrared Photography<sup>1</sup>

Paul Cuplin<sup>2</sup>

---

Abstract.--Variables that can be photointerpreted from large scale color infrared airphotos with ground data and used to monitor change in stream/riparian areas are stream width; floodplain width; stream channel stability; stream bank stability; stream shade; ground cover of trees, shrubs, and herbaceous vegetation; bare soil; riparian area and width; and density and structure of large trees and shrubs.

---

## INTRODUCTION

Remote sensing is the collection and analysis of information about lands and resources, using a device not in physical contact with the lands or resources. Remote sensing includes techniques such as analysis of satellite, Side Looking Airborne Radar, thermal infrared scanning data; and the interpretation of aerial photography.

The size and shape of riparian areas can often be determined from satellite digital analysis or interpretation of small-scale airphotos. However, large-scale airphotos at scales ranging from 1:1,000 to 1:4,800 are needed to interpret detailed information on streams and riparian vegetation. The 1:1,000 scale is preferred for ease of photo interpretation and good resolution. It is difficult to obtain stereo coverage at 1:1,000 scale due to 9- x 9-inch film recycling speed and safe low-level aircraft altitude. The compromise scale of 1:2,000 is acceptable and obtainable.

Color infrared photographs are especially valuable for vegetation analysis. Color tones, along with shape, size, pattern, shadow, and texture, are used to identify individual tree and shrub species in riparian areas.

Types of riparian vegetation information that can be collected on the ground are vegetation type and subtype; width of riparian vegetation zone; species composition of shrubs, trees, grasses, and forbs; bare soil; plant density by species; condition class; plant reproduction; upward, downward, or stable trend; tree and shrub structure; and potential natural vegetation community.

Photo interpretation of large-scale airphotos combined with ground truthing produces a smaller list of riparian vegetation information that can be determined. These variables are as follows: vegetation type and subtype; width of riparian vegetation zone; riparian area acreage; structure of trees and shrubs; percent ground cover of trees, shrubs, and herbaceous vegetation; percent bare soil; and density of large shrubs and trees.

Stream variables that can be measured from the airphotos are stream width, stream channel stability, streambank stability, floodplain width, and stream shade.

Subtle changes in riparian vegetation are difficult to detect on airphotos. Conversely, catastrophic changes due to flooding can be easily monitored, and the amount of riparian area lost can be readily calculated.

The method used to detect change in the stream/riparian area is to visually compare the baseline and monitoring airphotos. If changes are apparent, a sample site that appears in both airphotos is selected and key variables measured to determine the amount of change that has occurred.

## APPLICATION OF LARGE-SCALE AIRPHOTOS FOR INVENTORY AND MONITORING

Ground sampling or familiarity with the riparian vegetation photographed is essential for accurate photo interpretation. Vegetation transects and tree, shrub circular characterization plots are transferable in general terms to large-scale airphotos. Trees, and some shrubs, can be readily identified by species; grasses and forbs cannot be identified by species unless a photo scale of 1:100 to 1:300 is used. See table 1 for variables that can be identified on a scale of 1:2,000.

---

<sup>1</sup>Paper presented at the Riparian Ecosystems and Their Management Symposium, [Tucson, Arizona, April 16-18, 1985].

<sup>2</sup>Paul Cuplin is a Fishery Biologist, Bureau of Land Management, Denver, Colorado.

Table 1.--Variables that may be photo interpreted from 1:2,000 scale color infrared airphotos combined with on-the-ground data collection.

<u>Variable</u>	<u>Photo Interpretation</u>
Vegetation Type and Subtype	Yes
Riparian Area Width and Acreage	Yes
Plant Species Composition	
Trees	Yes
Shrubs	Yes, some shrubs such as willow and baccharis
Grasses	No
Forbs	No
Ground Cover	
% Trees	Yes
% Shrubs	Yes
% Herbaceous Vegetation	Yes
% Bare Soil	Yes
Density	Yes, large trees and some shrubs such as cottonwood and willow
Reproduction	Yes, young trees and shrubs but not seedlings
Condition Class	No
Trend	Yes, as related to change in the amount of ground cover and bare soil
Potential Structure	No
Streambank Shade	Yes
Stream Width	Yes, height of trees and shrubs
Floodplain Width	Yes
Streambank Stability	Yes
Streambed Silt	Yes
Stream Channel Stability	Yes

#### BASELINE

Original large-scale airphotos of a riparian area provide an overview of existing conditions in terms of the readily interpreted variables. Subsequent airphotos over time provide the means of detecting change in these variables. Subtle change due to the lack of or above normal precipitation may not be evident as compared to the catastrophic change caused by a 100-year flood.

The most easily detected changes in a riparian area would be a reduction in foliar cover and an increase in bare soil. These changes may be obvious upon inspection of the baseline (original) photo compared with the monitoring photo taken five to ten years later. The cause of the change may be answered only by on-the-ground inspection; thus the photos offer the opportunity to monitor change but not the cause.

#### GROUND DATA COLLECTION

Select ground data sites that are accessible and representative of the riparian vegetation and stream conditions. One site per 1- to 3-mile stream segment may be sufficient for airphoto interpretation. If there are significant differences in a stream segment, additional data collection sites should be established.

#### ON-SITE DATA COLLECTION

- . Take color print 35-mm photographs of the stream/riparian area (upstream, across stream, and downstream) at the site where the airphoto target is placed.
- . Collect stream inventory of 1/10 mile of stream segment.
- . Determine the dominant and subdominant herbaceous vegetation, shrubs, and trees, and the percent bare soil.
- . Take additional field notes that may assist in photo interpretation.

#### ACQUISITION OF LARGE-SCALE LARGE-FORMAT (9- x 9-INCH) AERIAL PHOTOGRAPHS

The 9- x 9-inch format is easy to work with, and most photo interpretation can be accomplished with a minimum of equipment. The 9- x 9-inch photos are identified by date, fiducial marks, agency, photo scale, state symbols, roll number, and exposure number. Photos can be easily filed, and extra prints can be ordered as needed for field use.

A 9- x 9-inch format photo covers approximately 52 acres, or 2,250,000 square feet, at a scale of 1:2,000. At this scale, riparian zones on first, second, and third order streams are easily photographed with a good margin of the adjacent upland.

Assistance on airphoto acquisition should be sought from a remote sensing coordinator. The publication "Aerial Photography Specifications," June 1983, BLM, is available from the Branch of Remote Sensing (D-442), Denver Service Center, BLM. This publication provides detailed specifications for acquiring aerial photographs via contract.

Provide the photographer with a USGS quad map that shows the beginning and end of each stream/riparian area to be photographed. Delineate flight lines on the maps to indicate to the photographer the direction of airplane travel and the midpoint and width of each flight line according to the photo scale that has been requested.

#### SUGGESTED STREAM/RIPARIAN INVENTORY AND MONITORING PROCEDURES USING LARGE-SCALE COLOR INFRARED AIRPHOTOS AND GROUND DATA

##### Baseline Inventory

- . Identify the stream/riparian segment.
- . Describe existing conditions for the stream/riparian segment.
- . Identify resource needs and concerns.

##### Area Management

- . Describe the management for the area.
- . Identify the objectives and management goals for the area.
- . Identify improvement goals and the changes, such as increasing the amount of ground cover, narrowing stream width, or increasing the number of trees and shrubs, that can be measured.

##### Variables

Variables that can be used to easily detect changes are as follows:

- . Ground cover--An increase or decrease in ground cover of trees, shrubs, and herbaceous vegetation, and in bare soil can be detected by visual observation of large-scale airphotos.
- . Stream width--Changes in stream width can be easily measured on large-scale airphotos. These changes are an early indicator of improving or degrading stream conditions. Stream width increases under heavy livestock grazing and narrows during the recovery period of no livestock grazing.
- . Channel and bank stability--Stream channel and streambank stability can be readily interpreted from large scale airphotos.
- . Size of riparian area--Riparian area width and acreage can be readily measured on large-scale airphotos.

##### Sample Size

The sample size used to determine change should be large enough to represent the area and the changes that have occurred. Select a representative site that can be identified on both baseline and monitoring airphotos.

##### Accuracy

Determine the accuracy required to assess a variable to assure that the correct variable is being assessed and that changes are the result of management and not the result of natural variation caused by precipitation or other influences.

##### Results

If results are uncertain, select other comparative areas for analysis. From the changes detected in photo interpretation, determine if management objectives were achieved.

##### CONCLUSIONS

The use of large-scale color infrared airphotos for inventory and monitoring riparian areas is best applied at a scale of 1:2,000 in 9- x 9-inch format.

Airphotos that were taken from a small bubble type helicopter while using a handheld 35-mm camera have application to small projects. However, if several miles of stream/riparian area are to be photographed, it can best be done by an airphoto contractor with a 9- x 9-inch mapping camera.

Variables that can be photointerpreted from large-scale color infrared airphotos with ground truth and that can be used to detect change in the stream/riparian area are stream width; floodplain width; stream channel stability; stream bank stability; stream shade; ground cover of trees, shrubs, and herbaceous vegetation; bare soil; riparian area and width; and density and structure of large trees and shrubs.

##### LITERATURE CITED

U.S. Department of Interior, Bureau of Land Management. 1983. Aerial Photography Specifications. BLM Denver Service Center. Denver, CO. 15pp.

# Glen Canyon Environmental Studies: An Interagency Effort to Resolve Resource Management Conflicts<sup>1</sup>

John R. Thomas<sup>2</sup>

---

Abstract.--The Glen Canyon Environmental Studies are a cooperative effort between four federal and state agencies to quantify the effects of Glen Canyon Dam operations on natural and recreational resources in Glen and Grand Canyons and to develop mitigation strategies for demonstrated impacts.

---

## INTRODUCTION

The history of modern man's utilization of the Colorado River is one of controversy. As development of the arid Southwest progressed, the Colorado River was looked upon as the salvation of water hungry enterprises. Laws, regulations, and agreements were developed to allocate the waters of the Colorado River, effect flood control and irrigation, and generate power. Often projects which were designed to serve one entity were viewed by other parties as detrimental to their interest. In 1982, a proposal by the Bureau of Reclamation (BR) to increase the power generation capacity of Glen Canyon Dam through generator uprating (BR 1982a) resulted in conflict over the priority given power generation versus environmental concerns. The Glen Canyon Environmental Studies (GCES) were initiated to facilitate resolution of this conflict through detailed evaluation of the impact of dam operations on instream resources below Glen Canyon Dam. This paper will discuss the GCES and the agencies involved.

The purpose of the GCES is to quantify the impacts of existing flow regimes and the increase of maximum release capacity through uprating to 33,100 cfs. If the GCES demonstrate that current operations have a detrimental impact on downstream resources then recommendations for alternative operating criteria will be made. These recommendations will be evaluated through an environmental impact statement process.

1

Paper presented at the First North American Riparian Conference, Tucson, Arizona, April 16-18, 1985.

2

Resources Management Specialist, Grand Canyon National Park, Arizona.

The GCES are being conducted as a cooperative interagency effort by agencies with management responsibilities for the Colorado River in Glen and Grand Canyons. This cooperative effort is notable as management goals and policies of the participating agencies can be, and frequently are, in disagreement. The involved agencies and their mandates are:

BR, to construct and operate water development and flood control projects,

National Park Service (NPS), to perpetuate natural processes and provide visitor use opportunities within the national parks,

Arizona Game and Fish Department (AGFD), to manage terrestrial and aquatic wildlife resources within Arizona for consumptive and nonconsumptive use, and

U.S. Fish and Wildlife Service (USFWS), to preserve migratory and endangered wildlife on federal lands.

On one hand is BR, an agency with a clear development mandate. On the other is NPS, USFWS, and AGFD, agencies with preservation or conservation mandates. That these two groups would have conflicting goals regarding the management of a common resource is almost inevitable.

## Generator Uprate Proposal

A major aspect of BR's mission at Glen Canyon Dam is the generation of electrical power. The original Glen Canyon generators were not capable of utilizing the full capacity of the penstocks and turbines. Increasing generator capacity, or uprating, would allow a maximum output from the power plant of 1,336 megawatts, an increase of 168 MW (BR 1982a). The uprate would result in the potential for a 1600 cubic feet per second (cfs) in-

crease in the maximum water discharge through the powerplant (31,500 to 33,100 cfs).

In February 1982, a draft environmental assessment for uprating the Glen Canyon generators was issued by BR (BR 1982a). The assessment met with substantial comment and concern from Grand Canyon interest groups, including government agencies with management responsibilities below the dam. These groups perceived a potential for exacerbation of ongoing impacts associated with dam operations as a result of increased maximum discharge and higher fluctuations. Comment on the assessment centered on two major points: 1) BR did not have a data base which could accurately describe impacts of uprating on downstream resources and 2) the assessment did not address impacts of existing Glen Canyon Dam operations exclusive of uprating (BR 1982b).

After release of the draft assessment, the involved agencies participated in extensive dialogue regarding the implications of the uprate and impacts of existing operations. A final environmental assessment was released in December 1982 with a Finding of No Significant Impact for generator uprating (BR 1982b). BR made a commitment in the final assessment to 1) determine how present operations impact the total riverine environment in Grand Canyon and to 2) undertake an analysis of alternative operating criteria to determine if feasible alternatives exist which will address concerns over existing operations. This commitment was to be met through a cooperative effort between BR, NPS, and USFWS with participation of other Federal and non-Federal agencies. The GCES are the foundation of this effort.

#### INFLUENCE OF GLEN CANYON DAM

The GCES are not addressing pristine systems. The resources of concern have been dramatically influenced by the dam and its operation. After completion of Glen Canyon Dam in 1963, drastic changes occurred in the physical and biological nature of the Colorado River in Glen and Grand Canyons. Historically, flow of the Colorado River ranged from 700 cfs in December 1924 to 127,000 cfs in July of 1927 (Carothers and Johnson 1983). Power plant discharges can now range from 1000 cfs to 31,500 cfs. Water temperature fluctuated seasonally from over 70 degrees F in the summer months, to less than 40 degrees F during winter. Water released through the power plant is now consistently 46 degrees F due to the location of penstock intakes below the thermocline of Lake Powell. Prior to the dam, sediment discharge through Grand

Canyon averaged 140 million tons annually with extremes ranging from 50 to 500 million tons. Upper basin sediments are now trapped in Lake Powell. As a result of these major habitat changes three of eight native fish species in Grand Canyon have been extirpated (Carothers and Johnson 1983).

Before completion of Glen Canyon Dam, spring floods scoured the river channel and reworked alluvial deposits. These floods no longer occur and as a result extensive riparian ecosystems have developed along the river at the new post-dam high waterline (Carothers and Johnson 1983). Vegetation established at the old pre-dam high waterline may be senescent as the watering and reproduction resulting from pre-dam floods no longer occurs.

Without floods, there is no mechanism to deposit sediment above the river stage associated with maximum power plant discharge. Erosion has resulted in a net loss of sand bar deposits in some areas in Grand Canyon (Brian and Thomas 1984). The continuation of this process will result in the loss of river runner campsites and substrate supporting Colorado River riparian ecosystems

Releases through the dam are controlled by electrical power demand and downstream water delivery commitments. Peaking power demands create a daily river tide. The resulting fluctuating flow pattern can result in low flows which are unpassable for river runners and have a yet to be determined impact on aquatic ecosystems.

In 1983, Lake Powell was not able to contain the spring runoff. It was necessary to bypass the power plant with releases through the spillways. Discharge ranged from 38,000 cfs to over 90,000 cfs during June, July, and August 1983 (personal communication, BR). Alluvial deposits were altered and riparian vegetation was impacted to varying degrees.

#### RESEARCH PROJECTS

The GCES are not directed at a single resource, but rather, the riverine environment as a whole. The study addresses this holistic approach through four sub-studies; Sediment Transport and Hydrology, Terrestrial and Aquatic Biology, Recreation, and Dam Operations. BR is the lead agency and is providing the majority of funding. BR staff fill the Project Manager and Sub-team leader positions. NPS, AGFD, and USFWS personnel are involved in the sub-teams which reflect their agencies' interests and expertise; Sediment Transport- NPS, Biology- NPS and AGFD, and USFWS, and

Recreation- NPS and BR.

The objective of the Sediment Transport studies is to describe the relationship between magnitude and fluctuation of discharge and the erosion, movement, and deposition of alluvial sediments. The first task is to model the relationship between channel erosion/deposition and various discharge patterns. To gather data necessary for modeling, sediment transport and discharge sampling stations have been established at five locations within the canyon and on three main Colorado River tributaries. Channel bottom surveys using side-scan sonar, acoustic-velocity profiler, and fathometer have been employed to quantify the volume of sediment in storage in the channel bed. Sand bar studies will investigate the susceptibility of beaches and banks to erosion under various discharge regimes. Sediment transport modeling will be integrated with sand bar research to predict sand bar longevity resulting from various flow regimes. Sediment transport and hydrology research is being conducted by BR, U.S. Geological Survey, and NPS.

Results of the sediment transport research will be pivotal for the recreation and biology studies. Accurate prediction of the influence of dam operations on recreation and biological resources requires that sediment transport relationships are well understood. The majority of river runners use sand bars for campsites, hence, the fate of these deposits is a major recreation issue. The species composition, densities, and spatial extent of terrestrial and aquatic communities are to a large degree determined by the substrates available. The future character of riparian and aquatic substrates is directly tied to erosion rates.

Aquatic biology research will evaluate management practices and elements of the post-dam Colorado River ecosystem which are both important to the fishery and influenced by dam operations. The research is being conducted primarily by AGFD. Aquatic research findings will be integrated with sediment transport study predictions regarding changes in substrate, velocity, and river stage as a function of specific flow regimes. The impact of dam operations on aquatic habitat and lower trophic level organisms will form the basis for evaluating effects on reproduction, development, distribution, and relative densities of native and exotic fishes. Research is divided into five main projects:

1. The importance of mainstream habitats for native and exotic fish species and the impact of fluctuating flows on those habitats.

2. The importance of tributaries for native and exotic species.

3. The effects of fluctuating flows on the life history of the alga Cladophora glomerata.

4. The effects of fluctuating flows on the life history of Gammarus lacustris and fish utilization of this amphipod.

5. The importance of stocking versus natural reproduction for the trout fishery.

The aims of the terrestrial biology research are to quantify the effects of dam operations on riparian vegetative community succession, herpetofauna and avifauna habitat; and to quantify impacts of the 1983 floods on riparian communities. Terrestrial biology research is being conducted by NPS, BR, and AGFD.

Riparian vegetation community substrate mapping based on 1960, 1973, 1980, and 1984 photography is being employed to evaluate succession and colonization trends. Habitat requirements for herpetofauna and avifauna including vegetation and substrate characteristics are being determined. The direct effects of fluctuating flows and floods on avifauna and herpetofauna are also being assessed. Impacts of the 1983 floods on new riparian zone vegetation are being quantified through comparison of pre-flood data sets with post-flood data. The effects of 1983 floods on old high waterline vegetation will be determined by measuring post-flood growth and reproduction rates and comparing this data to evidence of growth and reproduction in the post-dam/pre-flood era. This analysis will indicate if it is possible to perpetuate this habitat via periodic spills releases. Avifauna and herpetofauna density and diversity data are being gathered in both the old and new riparian zones.

Terrestrial biology research will determine the best case future scenario for the extent of riparian vegetation based on the direction and rate of succession and availability of substrates for colonization, effects of flow regimes including floods on the species composition and structure of these communities, and effect of changes in vegetation on avifauna and herpetofauna populations. Sediment transport research will predict the extent of available substrates under various flow regimes. These analyses will allow prediction of the future status of riparian ecosystem conditions under various flow regimes. If preservation of one habitat, old or new zone, requires the sacrifice of the other, then information on the relative importance of each in terms of flora and fauna density

and diversity will be available.

Areas of concern in recreation are the effect of flows on safety, on number of river runner contacts, and the ability of river runners to experience those aspects of Grand Canyon which they value, such as side canyon hikes and sand beaches for camping. The safety issue will be addressed through analysis of the correlation between accidents and flow levels. The Wilderness Use Simulation Model (Shechter and Lucas 1978) has been modified to define contact levels as a function of launch schedules. The relationship of contacts to flow will be determined by modifying the model to allow the incorporation of flow rates in the calculation of contact levels. A contingent valuation method study will be used to determine the relative value to the river runner of flow sensitive attributes of the Grand Canyon river experience.

The Operations study will define the legal and administrative constraints on Glen Canyon Dam operating criteria. The limits on mitigating strategies will be determined through this analysis.

The final project report will compile all of the component studies and describe impacts to downstream resources resulting from various flow regimes. Glen Canyon Dam operational strategies which mitigate impacts will be identified. If, as is probable, certain regimes favor one resource, including power generation, over another then the real nature of cooperation between the involved agencies will be exhibited. The recommendations for alternative operating criteria will result from a process of negotiation and compromise. If significant impacts are identified, an environmental impact statement process will be initiated.

this process will be based on the research findings and alternative operational strategies of the GCES.

If in decisions following the GCES, environmental concerns are considered on an comparable basis with power generation then a major precedent in Colorado River politics and management will have been established. This precedent will not diminish future conflicts, but will ensure a more even treatment for all resource values.

#### LITERATURE CITED

- Brian, J. N. and J. R. Thomas. 1984. 1983 Colorado River beach campsite inventory. Unpubl. report, Grand Canyon National Park, Arizona.
- Bureau of Reclamation. 1982 a. Draft environmental assessment for Glen Canyon powerplant uprating. Upper Colorado Region, Salt Lake City, Utah.
- Bureau of Reclamation. 1982 b. Finding of no significant impact for Glen Canyon powerplant uprating. Upper Colorado Region, Salt Lake City, Utah.
- Carothers, S.W. and R.R. Johnson. 1983. Status of the Colorado River ecosystem in Grand Canyon National Park and Glen Canyon National Recreation Area. in Proceedings of the 1981 Symposium on Aquatic Resources Management of the Colorado River Ecosystem, Utah State University, Logan, Utah.
- Shechter, M. and R.C. Lucas. 1978. Simulation of recreational use for parks and wilderness management. Resources for the Future, Inc. Johns Hopkins University Press. Baltimore, Maryland.

# Glen Canyon Dam, Fluctuating Water Levels, and Riparian Breeding Birds: The Need for Management Compromise on the Colorado River in Grand Canyon<sup>1</sup>

Bryan T. Brown<sup>2</sup> and R. Roy Johnson<sup>2</sup>

Abstract.--Large water releases from Glen Canyon Dam in May and June are harmful to riparian breeding birds along the Colorado River in Grand Canyon. Nest inundation can be avoided by releasing surplus water at times other than the breeding season. Habitat loss is the most serious long-term threat to riparian birds.

## INTRODUCTION

The completion of Glen Canyon Dam in 1963 signalled a temporary end to floods which swept down the Colorado River through Grand Canyon. Annual pre-dam floods averaging 86,000 cubic feet per second (cfs) would scour the riverbanks of virtually all riparian vegetation except for a narrow band of riparian scrubland above the old high water mark. Floods of up to 120,000 cfs would occur once every ten years before the dam, with the largest known pre-dam flow being 300,000 cfs (Turner and Karpiscak 1980).

Controlled water releases from Glen Canyon Dam greatly reduced the maximum annual flows in the river. Maximum annual flows averaged 31,000 cfs during the period 1963 to 1979 (fig. 1). This allowed a new band of woody riparian habitat to develop in the pre-dam scour zone where only ephemeral and annual plants had previously occurred (Turner and Karpiscak 1980). The old-high-water-zone (OHWZ) vegetation which existed under the pre-dam water regime consisted primarily of mesquite (*Prosopis glandulosa*), catclaw acacia (*Acacia greggii*), and netleaf hackberry (*Celtis reticulata*). Below the OHWZ was the new-high-water-zone (NHWZ), a dense scrubland of rapidly-developing salt cedar (*Tamarix chinensis*), *Baccharis* spp., arrowweed (*Tessaria sericea*), and willow (*Salix* spp.) (Carothers and Aitchison 1976).

Riparian birds quickly colonized the NHWZ, with some species even expanding their ranges upriver to take advantage of the new habitat (Brown et al. 1983). By the early 1970s, the NHWZ

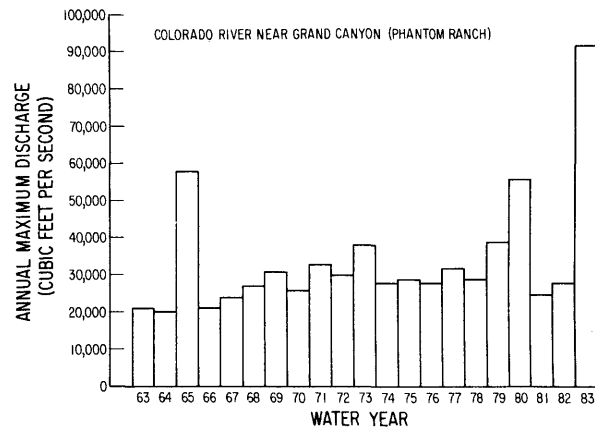

Figure 1. Annual maximum discharge of the Colorado River in Grand Canyon, 1963 to 1983.

habitats probably exceeded OHWZ habitats in avian diversity and equalled or exceeded them in avian density; by the early 1980s this was definitely the case (Brown and Johnson, ms. in prep.). From the short-term perspective of twenty years, the dam has clearly been a benefit to riparian breeding birds. The increase in riparian habitat and associated avian densities has also been, in effect, mitigation for riparian habitat and bird populations lost when Glen Canyon was inundated by Lake Powell. The new riparian habitat in Grand Canyon National Park is the most substantial increase in riparian habitat acreage in the Southwest within the last several decades (Johnson 1978).

Lake Powell reached maximum pool elevation in 1979-80. The filling of the lake coincided with several years of above average snowfall and runoff in the Colorado River drainage, resulting in larger than expected inflow to Lake Powell. These large inflows made necessary the release of large amounts of water through the spillways of Glen Canyon Dam. River flows reached 50,000 cfs during

<sup>1</sup>Paper presented at the North American Riparian Conference, Tucson, Arizona, April 16-18, 1985.

<sup>2</sup>Ecologist and Senior Research Scientist, respectively, Cooperative National Park Resources Studies Unit, University of Arizona, Tucson 85721.



the first spillway release of June 1980; a spectacular spillway release in June 1983 reached over 93,000 cfs (fig. 1), inundating much of the NHWZ and eroding away a substantial portion of NHWZ vegetation (personal observation). Floods had returned to the Grand Canyon section of the Colorado River.

The purpose of this study is to document the effects of high water releases on obligate riparian breeding birds along the Colorado River in Grand Canyon. The June 1983 high water release will be used as a primary example of these effects. The specific objectives are: 1) quantify nest loss through inundation by various release levels; 2) document avian density changes resulting from the high water release; and 3) predict the future of riparian birds under the new flow regime. Obligate riparian breeding birds were the target organisms chosen for study since they are limited to riparian areas, making them more sensitive to riparian habitat manipulations and more in need of attention from management (Johnson et al. 1977). Information on the long-term effects of high water releases on riparian birds will be useful in making decisions about the long-term management goals for both the dam and the river.

## METHODS

### Study Area

The study area consists of the Colorado River corridor in Grand Canyon National Park between Lees Ferry and Diamond Creek, a distance of 225 miles. Areas of primary study included Cardenas Creek, Fern Glen Canyon, Lava Falls, Whitmore Wash, Parashant Wash, and Granite Park. A number of secondary sites, ranging in size from less than 1 ha to approximately 5 ha, were also examined.

### Procedures

Data on nest location and nest height were gathered in April, May, and June of 1982. Nests were located by coordinated, systematic searches of the vegetation, after which nests were mapped and marked nearby for relocation. Call counts of conspicuous species of obligate riparian birds were made after the methods of Bull (1981), in which singing males were counted during an 18-day, oar-powered float through the study area. Call count data was gathered at all times of day, resulting in an index to population density. The presence of eggs or young was recorded for nesting chronology analysis.

All of the study sites were visited from June 7 to 24, 1983, to determine if or to what extent the known nests of riparian birds were inundated by the high water. Nests were relocated and the water depth at or below the nest recorded to the nearest 0.1 m. Amounts of water released and river level values are from the U.S. Geological Survey gauging station at Phantom Ranch, 104 miles downstream from the dam, or from the U.S. Bureau of Reclamation at Page, Arizona. Water releases

from the dam and river level values were generally equivalent during June 1983, as the river quickly stabilized following the few fluctuations.

It was possible to extrapolate back to the approximate cfs level at which a specific nest was inundated by using known values of nest height, depth of water at the nest, and river flow figures. Subtracting the depth to which a nest was inundated from the gauge height reading for the previous day would yield this information. For example, a certain nest at Parashant Wash was 1.24 m below the surface of the river on June 21, at river flows of 62,000 cfs (Phantom Ranch gauge height of 6.94 m)(USGS unpublished data). The nest appears to have been initially inundated at flows corresponding to gauge heights of 5.70 m (6.94 minus 1.24), or 41,170 cfs (USGS unpublished data). The gauge height at Phantom Ranch, however, is not equivalent to river height at Parashant Wash, causing the initial inundation estimate to be slightly inaccurate. The inundation figures which have been extrapolated with this method are only accurate to within a range of plus or minus 2,500 cfs. A rise to the 93,000 cfs range was assumed to have caused a 0.5 m rise over those water levels measured at 62,000 cfs (the level at which most data was gathered). The actual rise at the Phantom Ranch gauge for the increase was 0.9 m, resulting in inundation figures at 93,000 cfs which are somewhat conservative.

Obligate riparian birds which are considered here are Willow Flycatcher (Empidonax traillii), Bell's Vireo (Vireo bellii), Yellow Warbler (Dendroica petechia), Common Yellowthroat (Geothlypis trichas), Yellow-breasted Chat (Icteria virens), Blue Grosbeak (Guiraca caerulea), Hooded Oriole (Icterus cucullatus), Northern Oriole (I. galbula), and Indigo Bunting (Passerina cyanea). Marsh Wren (Cistothorus palustris) and Summer Tanager (Piranga rubra) may also nest rarely and locally in the river corridor, but no nests of these species were located.

### Site Selection

Data collection was designed so that the sample of nests found was a representative sample of the nest site preferences of each species. To ensure this representative sample, each habitat type was sampled in direct proportion to its relative occurrence. Since NHWZ habitats comprised approximately 75% of the total vegetation present along the river, 75% of the sample time was spent searching for nests in the NHWZ. Accordingly, 25% of the total sampling time was spent searching OHWZ habitats.

## RESULTS AND DISCUSSION

### Nest Inundation

Interim results indicate that normal flows of up to 31,000 cfs do not endanger the nests of

obligate riparian birds, as it is only the higher flows which cause nest inundation. Bell's Vireo, Common Yellowthroat, and Yellow-breasted Chat are the three species of obligate riparian birds which were known to experience nest loss through inundation during the June 1983 high water release (table 1). This is primarily due to their nest placement preferences: these species nest both low to the ground and close to the water (Brown and Johnson, ms. in prep.).

Table 1. Nest inundation at 62,000 cfs during the high water of June 1983. Sample size (N) follows names.

Species	Nests Inundated	
	No.	%
Willow Flycatcher(2)	0	0
Bell's Vireo(75)	45	60
Yellow Warbler(2)	0	0
Common Yellowthroat(1)	1	100
Yellow-breasted Chat(19)	2	11
Blue Grosbeak(0)*	-	-
Hooded Oriole(2)	0	0
Northern Oriole(1)	0	0
Indigo Bunting(1)	0	0

\*No nests of this species were under observation at this time.

The high percentage of yellowthroat nests known to have been inundated is not just a result of the small sample size for this species (N=1, or less than 5% of the known population). Yellowthroat nest inundation began to occur at lower release levels than for vireo or chat nests, largely due to yellowthroat nest placement just above the surface of the ground or water in low-lying areas. The only known yellowthroat nest was extrapolated to have been inundated by releases of 36,000 cfs. Based on later work and a larger sample size, the height of this nest above water was found to be near the mean for this species, strongly indicating that the majority (ca. 90%) of yellowthroat nests were inundated by the initial rise to the 40,000 cfs level. This would identify Common Yellowthroat as the species most susceptible to significant nest loss through inundation.

The percentage of vireo nests inundated by various release levels is indicated in figure 2. Vireo nests began to be inundated at river flows of 41,000 cfs, but the largest number of nests inundated per 1,000 cfs rise was in the 49,000 to 62,000 cfs range. The percentage of chat nests lost to various release levels is illustrated in figure 3. Some chat nests were inundated by releases as low as 36,000 cfs, although only a small percentage of chat nests were lost to flows of 62,000 cfs or less.

The initial rise to 62,000 cfs in mid-June coincided exactly with the peak of nesting for yellowthroats and chats. Bell's Vireo nesting had

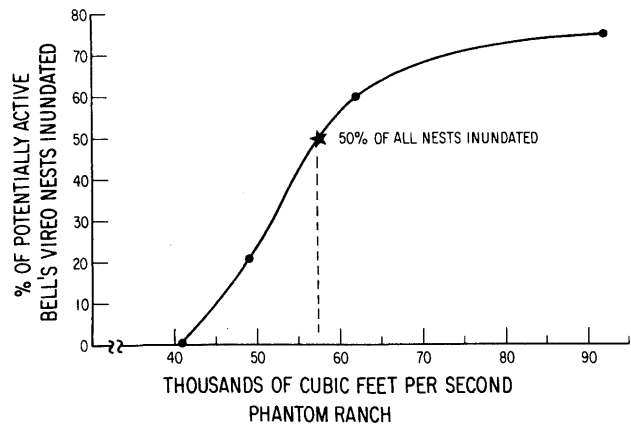

Figure 2. Percent of Bell's Vireo nests inundated at various release levels, June 1983.

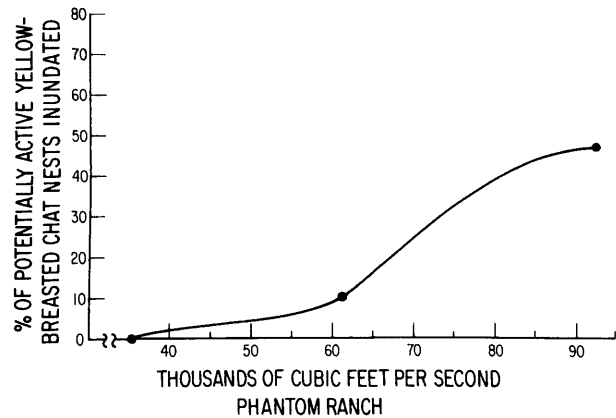

Figure 3. Percent of Yellow-breasted Chat nests inundated by various release levels, June 1983.

just passed its peak at that time (Brown and Johnson, ms. in prep.). At levels of 62,000 cfs, 100% of yellowthroat nests and 11% of chat nests were inundated (table 1); 100% of these were active (eggs or young present) at the time. The timing of the high water release was at the worst possible time for these two species. Sixty percent of the vireo nests were inundated by the same flows, but only 46% of these nests were active. By multiplying percent inundated by percent active (.60 x .46), it is apparent that only 28% of the active vireo nests were lost. If the initial rise to 62,000 cfs had occurred a short time earlier, a much higher percentage of active vireo nests would have been lost.

Vireos, yellowthroats, and chats all have the capability to renest if their nest is destroyed prior to the end of the breeding season. However, the persistence of high water into August reduced the possibilities of renesting.

## Avian Density Changes

Bell's Vireo is the only obligate riparian bird showing a marked decline in numbers (32% from 1982-84) after the June 1983 high water (table 2). However, it is normal for population densities of riparian birds in the Southwest to fluctuate in response to annual variations in precipitation, weather, and other factors. Avian densities along the Verde River of Arizona have been shown to vary by as much as 50% over a 2-year period, presumably due to environmental variations of this sort (Carothers and Johnson 1973).

Table 2. Densities of selected riparian birds between Lees Ferry and Diamond Creek, 1976 to 1985.

Species	No. singing males heard			
	1976*	1982	1983	1984
Willow Flycatcher	1	2	4	4
Bell's Vireo	67	135	70**	92
Yellow Warbler	17	32	39	33
Common Yellowthroat	8	-	-	21
Yellow-breasted Chat	18	46	53	65

\*Average absolute density from Carothers and Aitchison (1976).

\*\*Inaccurate census due to poor weather.

The Bell's Vireo decline was independent of a simultaneous decline in other species (with the possible exception of Common Yellowthroat, for which density data is unavailable). It is hard to overlook the substantial reduction in NHWZ habitats which accompanied the high water, together with a simultaneous loss of 28% of active vireo nests, and the effect this would have on vireo populations the following year. The Grand Canyon vireo population is at the northern limit of its range in Arizona and is somewhat geographically isolated from main population centers, resulting in a population more susceptible to local perturbations due to limited immigration. For these reasons, the vireo population decrease from 1982 to 1984 must be seen largely as a result of the June 1983 high water event.

### CONCLUSIONS AND MANAGEMENT IMPLICATIONS

The release of large amounts of water from Glen Canyon Dam can have significant negative effects on downstream riparian breeding birds. Nest inundation begins to occur at flows of ca. 36,000 cfs and nest losses of 50% or more for Bell's Vireo and Common Yellowthroat begin to occur at flows from 40,000 cfs to 62,000 cfs.

Releases above 36,000 cfs should be avoided during May and June, although this is unfortunately the exact time at which the peak runoff into Lake Powell occurs and the need arises to release surplus water. Nest inundation can be avoided by releasing surplus water at times other than the peak of the breeding season whenever the possibility of surplus water in May and June is

foreseen. Adequate flood storage could be maintained in Lake Powell by lowering the reservoir level prior to the peak runoff, a compromise that may occasionally be necessary to prevent widespread nest loss to downstream birds.

The nest loss and subsequent vireo population decline resulting from the June 1983 high water release is a relatively short-term effect from which bird populations can be expected to naturally recover. However, a series of repetitive high water releases would result in long-term instability for the obligate riparian bird community, a situation which would reduce avian density and diversity.

The rate of sediment loss from the river is the most important long-term question regarding the future of riparian birds downstream from Glen Canyon Dam. The dam traps sediment behind it, and the clear water released downstream may pick up and transport sediment out of the river corridor. Sediment loss would eventually result in a loss of riparian vegetation through erosion, a process which caused substantial losses of NHWZ vegetation during the June 1983 high water release. It is essential to understand the effect of dam operations on sediment transport, in order to predict the influence this might have on riparian vegetation and the birdlife associated with it. Studies in progress by the U.S. Geological Survey should quantify the rates of erosion and sediment loss associated with specific flow regimes, but it will be 1987 before this data is available.

A worst-case scenario of future sediment loss would be the nearly total loss of NHWZ habitats. Seven of the nine species of obligate riparian birds along the river are limited primarily to the NHWZ (Brown and Johnson, ms. in prep.). The NHWZ also hosts the great majority (from 50-90%, depending on the species) of the populations of obligate riparian birds in the entire Grand Canyon region (Brown and Johnson, ms. in prep.). For this reason, the complete or partial loss of NHWZ habitats would have a disproportionately negative impact on their regional well-being.

The future of obligate riparian birds along the Colorado River will be largely determined by those who manage Glen Canyon Dam. It is the responsibility of these managers to strike an acceptable compromise that will satisfy both hydroelectric power generation and flood storage needs as well as maintain the diversity of the riparian bird community in Grand Canyon.

### ACKNOWLEDGMENTS

J.R. Thomas and D.L. Wegner made valuable comments on the manuscript. This study was funded by the Bureau of Reclamation and the National Park Service.

### LITERATURE CITED

Brown, B.T., S.W. Carothers, and R.R. Johnson. 1983. Breeding range expansion of Bell's

- Vireo in Grand Canyon, Arizona. Condor 85:499-500.
- Brown, B.T., and R.R. Johnson. In preparation. The effect of fluctuating water levels from Glen Canyon Dam on riparian breeding birds along the Colorado River in Grand Canyon National Park. Final project report, USDI Bureau of Reclamation, Upper Colorado Region.
- Bull, E.L. 1981. Indirect estimates of abundance of birds. Studies in Avian Biology 6:76-80.
- Carothers, S.W., and S.W. Aitchison (Eds.). 1976. An ecological survey of the riparian zone of the Colorado River between Lees Ferry and Grand Wash Cliffs. Colorado River Tech. Rpt. No. 10, Grand Canyon National Park, Arizona. 251 pp.
- Carothers, S.W., and R.R. Johnson. 1973. A summary of the 1972 Verde Valley breeding bird survey. Completion Rpt. FW 16-12, Arizona Game and Fish Dept., Phoenix.
- Johnson, R.R. 1978. The Lower Colorado River: a western system. USDA For. Serv. Gen. Tech. Rpt. WO-12:41-55.
- Johnson, R.R., L.T. Haight, and J.M. Simpson. 1977. Endangered species vs. endangered habitats: a concept. USDA For. Serv. Gen. Tech. Rpt. RM-43:68-79.
- Turner, R.M., and M.M. Karpiscak. 1980. Recent vegetation changes along the Colorado River between Glen Canyon Dam and Lake Mead, Arizona. U.S. Geol. Survey Prof. Pap. 1132, U.S. Govt. Print. Off., Washington, D.C. 125 pp.

# The Effects of Prolonged Flooding on the Riparian Plant Community in Grand Canyon<sup>1</sup>

Lawrence E. Stevens and Gwendolyn L. Waring<sup>2</sup>

---

Abstract. Flood-induced removal, drowning, and estimated total mortality levels of perennial riparian plants were high, with significant differences between species following flooding of the Colorado River corridor downstream from Glen Canyon Dam in 1983-1984. Proximity to the river (duration of inundation), substrate type, and plant height (age) were correlated with mortality. Differential mortality and colonization by seedlings may result in riparian plant community change in this system.

---

## INTRODUCTION

Flooding is the most ubiquitous form of disturbance in riparian ecosystems. In unregulated streams it limits riparian plant community development (Campbell and Green 1968), while reduced flooding in dam-controlled streams permits plant life to colonize streambanks (Turner and Karpiscak 1980), creating ecologically and recreationally valuable riparian habitat (Johnson and Jones 1977). Flooding events subsequent to discharge regulation alter riparian plant community structure through damage and mortality of streamside plants.

Numerous factors influence flood-related plant mortality. Mortality varies with plant age and between species, and inundation resistance increases with plant age (Hosner 1958; Horton et al. 1960; Warren and Turner 1975; Kozlowski 1984). Prolonged flooding negatively affects leaf, shoot, cambial and root growth and morphology, and successful seedling establishment varies widely between plant species following flooding (Kozlowski 1984). Abiotic factors that influence mortality include water temperature, oxygen

depletion and other changes in inundated soils (Ponnampertuma 1984), duration and stage of flooding and turbidity (reduced light intensity).

Recent flooding events in the Colorado River corridor downstream from Glen Canyon Dam provided an opportunity to study the effects of flooding on riparian vegetation in a dam-controlled system. On 29 June, 1983 discharge from Glen Canyon Dam reached 2,621m<sup>3</sup>/sec in the Colorado River corridor in Grand Canyon, and flows remained at twice the normal level through 1984. The flood peak was the largest to pass through Grand Canyon in the post-dam (post-1963) era of regulated discharge, and the event exerted significant impacts on the riparian plant community there.

To determine the impact of this flooding event on the riparian plant community in the Colorado River corridor in Grand Canyon, we posed the following questions: 1) Do all riparian plant species respond to flooding in a similar fashion in this system? 2) Do floodstage, reach type, substrate type, distance from Glen Canyon Dam, stem density, and stem height influence flood-induced plant mortality? 3) How do different plant growth and reproductive strategies (e.g. sexual versus clonal strategies) affect survival and recovery? 4) Can flood-induced colonization compensate for differential mortality of adult plants? 5) Lastly, did riparian plant community composition change as a result of the flooding event? We present preliminary results of our findings in this paper.

---

<sup>1</sup>Paper presented at the symposium on riparian ecosystems and their management. [University of Arizona, Tucson, April 16-18, 1985].

<sup>2</sup>Lawrence E. Stevens and Gwendolyn L. Waring are graduate students in the Department of Biology at Northern Arizona University, Flagstaff, Arizona.

## METHODS

To answer these questions we collected data from several sources. River-based surveys of the riparian corridor in 1983 and 1984 provided three data sets on removal of plants by scouring flood waters: 1) the presence and condition of plants under observation since 1980 was determined in 1984 following the final subsidence of flows  $>700\text{m}^3/\text{sec}$ ; 2) three reaches were censused by counting all shrubs and trees in 1982 and 1984, between miles 60-61, miles 166.5-179.5 (for Prosopis only), and miles 196.5-198.0; and 3) nine 10m x 30-40m study sites, each situated with its long axis parallel to the river and less than 5m from the  $700\text{m}^3/\text{sec}$  stage were censused. These study sites were located between miles 43 and 170 (downstream from Lees Ferry) and were sampled for plant density and species composition in 1982 and 1984.

Information gathered from all sources included plant species, height, and condition, with distinct clumps considered as single individuals. The proximity of plants to the river (a measure of the period of inundation) was determined by dividing the total inundated area into three floodzones, all of which lay in Carothers et al. (1979) Zones 3 and 4<sup>3</sup>. Floodzone A =  $570\text{m}^3/\text{sec}$  to  $1,130\text{m}^3/\text{sec}$ ; Floodzone B =  $1,130\text{m}^3/\text{sec}$  to  $1,700\text{m}^3/\text{sec}$ ; and Floodzone C =  $1,700\text{m}^3/\text{sec}$  to  $2,400\text{m}^3/\text{sec}$ . Reach type categories included eddy, straight, riffle, or rapid settings. Substrate types included silt, sand, mixed sand and cobble, cobble, and bedrock. Distance downstream from Glen Canyon Dam was noted. Because virtually all of the post-dam riparian vegetation occurred below the  $1,700\text{m}^3/\text{sec}$  stage, data on plants larger than the seedling sizes from the floodzones A and B were pooled for analysis of removal.  $X^2$  analyses with the Yates correction for continuity (Brower and Zar 1977) were used to determine if removal was significant for each species.

<sup>3</sup>Carothers et al. (1979) described several parallel zones of post-dam riparian vegetation along the Colorado River in Grand Canyon. Below the desert talus slope vegetation (Zone 1), a pre-dam belt of Prosopis glandulosa, Acacia greggii and some Tamarix chinensis (Zone 2) grew down to the  $3,100\text{m}^3/\text{sec}$  water line (our estimate). Zone 3 (between the  $3,100\text{m}^3/\text{sec}$  and  $1,700\text{m}^3/\text{sec}$  stages) was only sparsely vegetated. Their Zone 4 ( $1,700\text{m}^3/\text{sec}$  to the water line) consisted of Tamarix, Salix, four species of Baccharis, Tessaria and other obligate riparian species (sensu Johnson and Lowe, this volume).

Mortality due to drowning of all perennial riparian species was measured on 47 transects in 1984. Transect sites were selected in the four reach types throughout the river corridor. Each transect was 30m in length and extended to the top of Floodzone C. The number and heights of live and dead plants (including seedlings) of each species were measured in each floodzone of each transect, and transect width was measured. The unflooded zone above the  $2,400\text{m}^3/\text{sec}$  line was not an appropriate control against which to compare flooded plants because growing conditions and sources of mortality were different there. Data were analyzed using  $X^2$  statistics, multiple linear regression and analyses of variance.

To evaluate the change in community structure resulting from this flooding event, we calculated Stander's community similarity index (Sullivan, 1975):

$$\text{SIMI} = \frac{\sum_i p_{ij} p_{in}}{\sqrt{\sum_i p_{ij}^2} \sqrt{\sum_i p_{in}^2}}$$

where  $p_{ij}$  and  $p_{in}$  are the proportions of species  $i$  in samples  $j$  and  $n$ , respectively. This statistic varies from 0 for entirely dissimilar communities to 1.0 for identical communities. We also calculated  $J'$  (Pielou 1977), a measure of the evenness of species' distributions which varies from 0 for highly uneven communities to 1.0 for communities with equal abundances of all species.

## RESULTS

### Discharge Data

The 1983-1984 flooding event was a prolonged, elevated discharge of cold, clear, well-oxygenated water. Minimum average current speed in straight reaches exceeded 3.0m/sec during the 1983 flood peak. Discharge data from Glen Canyon Dam (measured at the U.S. Geological Survey gauging station at Lees Ferry, Arizona) for this flood are presented in table 1.

Table 1: Discharge data from Glen Canyon Dam during the 1983-1984 flooding event, as measured at the U. S. Geological gauging station at Lees Ferry, Arizona<sup>4</sup>.

PERIOD	MEAN DISCHARGE ( $\text{m}^3/\text{sec}$ )	NUMBER OF DAYS OF HIGH DISCHARGE ( $\text{m}^3/\text{sec}$ )				MAXIMUM ANNUAL FLOW ( $\text{m}^3/\text{sec}$ )
		$>700$	$>1,130$	$>1,700$	$>2,260$	
1 October, 1982 to 30 September, 1983 (1982 Water Year)	683.7	147	56	35	8	2,603.6
1 October, 1983 to 30 September, 1984 (1983 Water Year)	750.0	99	64	0	0	1,282.0

<sup>4</sup>Mean discharge from 1963 to 1974 =  $359.8\text{m}^3/\text{sec}$ ; mean annual maximum flow =  $789.5\text{m}^3/\text{sec}$ . (Howard and Dolan, 1981).

## Plant Mortality Prior to 1983

In general, all plant species encountered in floodzones A and B were growing vigorously in 1982, with mortality levels less than 2%. Low density stands revealed pre-flood stem mortality levels; for example, mortality levels for Tamarix, Prosopis, and Baccharis species were 1.9% (n= 494), 2.2% (n=45), and 0.0% (n=448), respectively. Relatively high proportions of dead stems were encountered only in dense stands of Tamarix (38.6% to 44.0%, n=3 stands), Salix exigua (0.94% to 27.4%, mean=7.4% for 6 stands), and Tessaria (50.8%, n=1). We avoided using data from dense stands in our analyses.

### Flood-induced Plant Mortality

The percent mortality due to removal, drowning, and total estimated mortality of each common riparian plant species are presented in Table 2. Data were pooled for eddy and straight reaches in floodzones A and B in which most of the riparian corridor vegetation occurs. Estimates of total mortality are based on combined removal and drowning mortalities. Where removal data were not available (i.e. for less common species), removal was considered to be 0; therefore, the total mortality estimates are conservative.

Table 2: Percent removal, percent of remaining plants drowned, estimated total percent mortality, and seedling density/m<sup>2</sup> of common perennial plant species in the 700m<sup>2</sup>/sec to 1,700m<sup>2</sup>/sec riparian floodzone in the Colorado River in Grand Canyon.

SPECIES	PERCENT REMOVAL (n)	PERCENT DROWNED (n)	ESTIMATED TOTAL PERCENT MORTALITY	SEEDLING DENSITY/m <sup>2</sup>
<b>Deep Tap Roots</b>				
<u>Tamarix chinensis</u>	30.4 (4344)	20.7 (1981)	44.8	0.491
<u>Prosopis glandulosa</u>	0.9 (108)*	49.1 (118)	49.6	0.001
<u>Acacia greggii</u>	16.7 (35)*	37.6 (198)*	48.0	0.003
<u>Salix gooddingii</u>	0.0 (13)*	0.0 (13)*	0.0*	0.000
<b>Clonal, Shallow Roots</b>				
<u>Salix exigua</u> (ramet)	88.8 (12890)	6.7 (874)*	89.6	0.002 s
<u>Salix exigua</u> (clone)	6.8 (44)	0.0 (41)*	6.8*	---
<u>Tessaria sericea</u> (ramet)	74.7 (313)	11.8 (5285)	77.6	0.083 s
<u>Tessaria sericea</u> (clone)	23.1 (13)	18.2 (11)*	33.3	---
<u>Aster spinosus</u>	---	11.7 (922)	11.7	0.017
<u>Phragmites communis</u> (clone)	31.4 (20)	---	31.4*	0.000
<u>Typha</u> sp. (clone)	88.9 (11)	---	88.9	0.000
<u>Scirpus</u> sp. (clone)	100.0 (3)	---	100.0	0.000
<b>Shallow Roots</b>				
<u>Baccharis salicifolia</u> + <u>emoryi</u>	85.7 (567)	77.4 (565)	96.8	0.008
<u>Baccharis sarothroides</u>	52.1 (1010)	55.2 (721)	76.6	0.004
<u>Baccharis sergilloides</u>	---	63.6 (33)	63.6	0.000
<u>Brickellia longifolia</u>	---	75.7 (399)	75.7	0.015
<u>Aplopappus acradenius</u>	---	72.8 (184)	72.8	0.005
<u>Gutierrezia</u> spp.	---	30.2 (630)	30.2	0.006
Other mesic-adapted species	---	15.8 (76)*	15.8*	---
Other xeric-adapted species	---	42.9 (308)	42.9	---
MEAN TOTAL	51.8 (19358)	34.1 (12348)	59.2	0.643

Percent removal, drowning and total mortality values are significant within species

at p<0.005 (df=1) unless otherwise indicated.

\* -- p values not statistically significant (p > 0.05, df=1) for pre- versus post-flood counts.

s -- new shoots, not seedlings.

Levels of removal by scouring were significant within most species at p<0.005 and df=1; however, numbers of Phragmites communis genets, Salix gooddingii, Prosopis, and Acacia were not statistically different before and after 1983. Susceptibility to removal varied greatly between species. Three of the four species with deep tap roots suffered lower rates of removal than did shallow-rooted species. Removal data for Tamarix indicate that removal occurred at a significantly greater rate in Floodzone A (p<0.005, df=2). Because Tamarix is extremely well anchored, the trend of higher levels of removal at lower floodstages is probably valid for the other plant species as well. Clonal Phragmites, Salix exigua and Tessaria suffered high levels of areal loss of ramets, but because flooding rarely removed all of a clone's ramets, genet (total clone) mortality levels were low, ranging from 6.8% for Salix exigua to 31.4% for Phragmites. Clonal macrophytes, such as Scirpus and Typha, that occupied the river's edge prior to 1983, suffered removal rates of 88.9% to 100%.

Prior to 1983, large riverside beaches in eddy settings were usually occupied by Salix exigua, Tessaria, Tamarix and Baccharis, other perennials, herbs, and grasses. All plants on 12 of 15 such beaches were scoured away, and one of the three remaining beaches was left with only one Salix stem. The two remaining beaches lay on the inside of river meanders and were somewhat protected from substrate erosion. Excavations on four of five previously vegetated beaches revealed no root structure to at least 1.5m depth, and changes in sediment texture and bedding indicate that beach surface sediments were scoured and totally replaced in many instances. In several cases, the morphology of beaches redeposited by subsiding floodwaters was remarkably similar to that prior to the flood.

### Mortality due to Drowning

Rates of mortality due to drowning varied significantly between species (p<0.001, df=13,737) and within most species. All species except Acacia, Salix exigua ramets, and pooled miscellaneous species showed a significant decrease in density due to drowning (p<0.005, df=1 for each species). Salix exigua (6.7% mortality), Tamarix (20.7%), and several other riparian species were relatively tolerant of inundation, while Prosopis (49.1%), Baccharis spp. (55.2% to 77.4%), Aplopappus acradenius (72.8%) and Brickellia (75.7%) were intolerant

of inundation stress. Three of the four species with deep tap roots suffered relatively low levels of drowning mortality. Nearly all xeric-adapted species that had colonized post-dam beaches from the surrounding desert were intolerant of flooding. Desert Compositae, such as Dyssodia pentachaeta, Gutierrezia sarothrae, G. microcarpa, Aplopappus spinosus, Encelia farinosa, and Peucephyllum schottii suffered moderate to high levels of mortality, as did Ephedra spp., Larrea and various cacti species.

#### Mortality due to Burial

Mortality due to burial by newly deposited beach sediments could not be distinguished from drowning with these data; however, plant species were observed to respond differentially to this source of mortality. Many Tamarix plants that had been all but completely buried produced new shoots and appeared to be surviving in 1984. A Salix exigua clone at Mile 122.1R that had been buried in 1983 and then re-exposed in 1984, produced vigorous new growth. No Baccharis sarothroides plants that had been buried in 1983 were alive in 1984.

#### Factors Influencing Mortality due to Drowning

Transect data were used to assess the influence of plant density, plant height, distance from Glen Canyon Dam, reach type, floodstage (period of inundation), and substrate type on levels of mortality due to drowning. Analyses of variance showed that the latter two factors were significantly correlated with mortality due to drowning. Drowning was strongly correlated with floodstage for all species and locations ( $p < 0.001$ ,  $df = 2,748$ ), with 49.4% of all plants drowned in Floodzone A, 26.2% drowned in Floodzone B, and 17.7% drowned in Floodzone C. Range tests showed that mortality was significantly different in each of the three floodzones. Data for Tamarix by itself also showed that mortality attributed to drowning was strongly correlated with floodstage ( $p < 0.005$ ,  $df = 2,168$ ).

Drowning mortality varied significantly between the five substrate types ( $p < 0.01$ ,  $df = 3,747$ ), with lowest mortality on bedrock substrates (23.2%), moderate mortality in silt, sand, and sand-cobble mixed substrates (30.6% to 31.2%), and highest mortality on cobble substrates (53.8%). Range tests showed that cobble substrates were significantly different from the other

substrates. Substrate type and reach type (a measure of relative current velocity) are intercorrelated in this system: for example, sand or cobble substrates occur in eddy or riffle reaches, respectively. Two-way analysis of variance using factors of substrate type and reach type showed that drowning mortality decreased in sand substrates as current velocity increased, but mortality increased with velocity in cobble substrates.

Two-way analysis of variance of the mortality due to drowning of all species was also run for floodstage and substrate types. This analysis showed the highest levels of mortality (68.4%) occurred in cobble substrates in Floodstage A. This trend is further corroborated with data from cobble islands near miles 53 and 73, which had mean removal rates of 52.3% for Tamarix and 100% for Baccharis spp., and 93.7% mortality of remaining stems.

Analysis of variance showed that mortality due to drowning was negatively correlated with Tamarix plant height ( $R^2 = .236$ ,  $p < .001$ ,  $df = 9,220$ ). The percent variation in Tamarix mortality explained by reach type, floodstage, substrate, stem density, and distance from Glen Canyon Dam was greatest in plants 3m or more in height ( $R^2 = 41.2\%$ ,  $p < 0.004$ ,  $df = 8,40$ ) and  $R^2$  values decreased with plant height.

#### Colonization

Colonization is believed to be directly related to flooding events in this system (Hayden unpublished 1976). Following flooding in 1980, mean seedling densities of mixed species reached  $2,921/m^2$  ( $n = 6$ ) on previously uncolonized beaches. In September, 1983 dense Tamarix seedling beds were observed beneath the canopies of both the Tamarix study sites that had been inundated by floodwaters. This was the first colonization at these sites in 5 years of observation. Seedling densities ranged from  $4.5/m^2$  to  $330/m^2$ , with the higher germination taking place on a silt bed that had been deposited by tributary flooding. No Tamarix seedlings have ever been observed to germinate beneath the canopy of the Tamarix stand that was not inundated in 1983.

Analysis of transect data revealed that colonization effort was unequal between species (table 2). Tamarix seedlings were more than 5 times more abundant than any other species; however, subsequent mortality of Tamarix seedlings is expected to be extreme. At a density of  $0.003/m^2$ , Acacia seedlings



were three times as abundant as Prosopis seedlings and have relatively high survivorship. All clonal plant species showed a vigorous production of new shoots. Rapid recolonization of beaches was observed in Salix exigua, Tessaria, Phragmites, and Aster spinosus. Gutierrezia spp. and Dyssodia seedlings were the only talus slope species to recolonize the post-flood beaches in abundance, and recruitment may compensate for the loss of adult plants in these two species. Agave utahensis seedling density was significantly higher in Floodzone B than in other zones at some sites in Marble Canyon, and this species demonstrated a rapid and extensive colonization response to flooding.

#### Changes in Community Similarity

When adjusted for removal, pre- to post-flood plant community similarity decreased (SIMI=0.862), and evenness of species composition decreased slightly ( $J'$  pre-flood = 0.792 and  $J'$  post-flood = 0.761). By combining seedling data with adult plant data and recalculating these indices (assuming complete survivorship of seedlings), the maximum possible change in community structure resulting from this flooding event was estimated. The community similarity and  $J'$  values decreased dramatically (SIMI = 0.567;  $J'$  = 0.471), with the community more strongly dominated by Tamarix. Other community similarity and diversity statistics were calculated and agreed with these results.

#### DISCUSSION

The results presented above show that virtually all riparian plant species along the Colorado River in Grand Canyon are highly susceptible to flooding stress; however, between-species mortality rates are strongly differential. Shallow-rooted Baccharis spp. (Gary 1963), Brickellia longifolia, and Aplopappus acradenius, suffered higher levels of drowning than did species with deep tap-roots, such as Salix gooddingii, Tamarix chinensis (Gary 1963), Acacia greggii, and Prosopis glandulosa. Despite high levels of areal loss among several common clonal species (i.e. Phragmites communis, Salix exigua, and Tessaria sericea), a few ramets of most clones persisted, and overall clonal mortality rates were low. Xeric-adapted plant species, such as Ephedra spp., various cacti, Larrea tridentata, and Encelia farinosa, that had colonized riparian beaches from the surrounding desert were generally intolerant of inundation.

Floodstage, substrate type, and reach type were abiotic factors that correlated with mortality due to drowning, and the highest levels of mortality occurred in Floodzone A. The value of these factors in explaining drowning mortality was improved by excluding smaller height classes in the Tamarix data set. Distance downstream from Glen Canyon Dam and plant density were unimportant in explaining observed mortality.

Disturbance by flooding is a mechanism of community change in this system. It is evident from the results presented above that the 1983 flooding event served as a "weeding" event that decreased overall plant densities by scouring, drowning, and perhaps burial. Flooding decreased a small population of yellow Mimulus cardinalis at Mile 31.8R, but did not result in a large-scale loss of species from this system. Flooding did cause a range expansion of one species: Corispermum nitidum, was rare in the riparian zone prior to 1983 but became common on beaches throughout the river corridor in 1983 and 1984.

The immediate change in riparian plant community similarity was moderate as a result of this flooding event; however, long-term changes may have been initiated through promotion of colonization. For example, Acacia seedlings were previously rare compared to Prosopis, but now outnumber Prosopis seedlings on beaches and have a high survivorship. While recruitment of seedling colonists is not expected to be complete in this system, 80.0% of all plants encountered in the flood zone in 1984 were seedlings and it is apparent that this flooding event resulted in a "juvenescence" of the riparian plant community.

The riparian zone of the Colorado River was created with discharge regulation by Glen Canyon Dam; however, it is an ecologically and recreationally valuable naturalized riparian habitat (Carothers et al. 1979). Appropriate management of discharge in this system should include consideration of the potential effects of flood duration and stage on substrate erosion, differential mortality of adult plants, recruitment phenology and seedling survivorship, and the effect of flooding on riparian plant community structure and dynamics. It is relevant to note that floodstage was the abiotic factor most closely correlated with mortality by drowning, and is closely correlated with removal of Tamarix and other species. Such considerations are of obvious importance if the life of this riparian ecosystem is to be prolonged.

## ACKNOWLEDGMENTS

This research was supported by the Bureau of Reclamation/ National Park Service cooperative impact study of Glen Canyon Dam. We wish to acknowledge the support provided by David Wegner, John Thomas, and R. Roy Johnson. Valuable criticism on this manuscript was provided by Graydon Bell, Peter W. Price, and Christopher Sacchi of Northern Arizona University.

## LITERATURE CITED

- Brower, J.E. and J.H. Zar. 1977. Field and laboratory methods for general ecology. 194 p. W.C. Brown Co., Dubuque, Iowa.
- Campbell, C.J. and W. Green. 1968. Perpetual succession of stream channel vegetation in a semi-arid region. J. Ariz. Acad. Sci. 5: 86-98.
- Carothers, S.W., S.W. Aitchison, and R.R. Johnson. 1979. Natural resources, white water recreation and river management alternatives on the Colorado River, Grand Canyon National Park, Arizona. In R.M. Linn, ed. Proc. of the first conference on scientific research in the National Parks, I: 253-260.
- Gary, H.L. 1963. Root distribution of five-stamen tamarisk, seepwillow and arrowweed. Forest Sci. 9: 311-314.
- Hayden, B. 1976. The dynamics of an exotic on a man-altered system: Tamarix in the Grand Canyon. Unpublished National Park Service Report, 8 p. Grand Canyon, Ariz.
- Horton, J.J., F.C. Mounts, and J.M. Kraft. 1960. Seed germination and seedling establishment of phreatophyte species. Fort Collins, Colorado Forest Service Station Paper No. 48, 29 p. Rocky Mountain Forest and Range Experiment Station, Fort Collins, Colo.
- Hosner, J.F. 1958. The effects of complete inundation upon the seedlings of six bottomland tree species. Ecology 39: 371-373.
- Howard, A. and R. Dolan. 1981. Geomorphology of the Colorado River in the Grand Canyon. J. Geol. 89: 269-298.
- Johnson, R.R. and D.A. Jones. 1977. Importance, preservation and management of riparian habitat: a symposium. [Tucson, Ariz., July 9, 1977] USDA Forest Service Gen. Tech. Rept. RM-43. Tucson, 218 p. Rocky Mountain Forest and Range Experiment Station, Fort Collins, Colo.
- Kozlowski, T.T. 1984. Responses of woody plants to flooding, p. 129-164. In T.T. Kozlowski, ed. Flooding and plant growth. 356 p. Academic Press, Orlando, Fla.
- Pielou, E.C. 1977. Mathematical Ecology. 385 p. John Wiley & Sons. New York, NY.
- Ponnamperuma, E.N. 1984. Effects of flooding on soils. p. 10-45. In T.T. Kozlowski, ed. Flooding and plant growth. 356 p. Academic Press, Orlando, Fla.
- Sullivan, M.J. 1975. Diatom communities from a Delaware salt marsh. J. Phycology 11: 384-390.
- Turner, R. M. and M.M. Karpiscak. 1980. Recent vegetation changes along the Colorado River between Glen Canyon Dam and Lake Mead, Arizona. 125 p. U.S. Geol. Survey Professional Paper 1132. U.S. Government Printing Office, Washington, D.C.
- Warren, D.K. and R.M. Turner. 1975. Saltcedar (Tamarix chinensis) seed production, seedling establishment and response to inundation. J. Ariz. Acad. Sci. 10(3): 135-144.

# A Method for Evaluating Streamflow Discharge— Plant Species Occurrence Patterns on Headwater Streams<sup>1</sup>

Richard R. Harris, Roland J. Risser and Carl A. Fox<sup>2</sup>

---

Abstract.--On headwater streams proposed or developed for hydroelectric projects, hydrologic simulation modeling (Instream Flow Incremental Method) can be used in conjunction with vegetation sampling to assist in the evaluation of instream flow requirements for riparian plant species. Field studies on the western and eastern slopes of the Sierra Nevada have been undertaken to test the method and have shown promising results.

---

## INTRODUCTION

The objective of this research was to develop a procedure for sampling and analyzing riparian vegetation occurrence along headwater streams. Such a procedure is needed for determining vegetation instream flow requirements on streams proposed for or developed as hydroelectric projects.

Studies in other regions suggest that the positions of plants on riverine floodplains are related to the frequency, intensity, and duration of flooding (Bell 1980; Hack and Goodlet 1960; Hupp 1982). When natural flooding characteristics are changed due to streamflow diversions, species may be affected differently, depending on their positions on stream floodplains.

Fisheries biologists have recognized the need for assessing the instream flow requirements of resident fish life. The Instream Flow Incremental Method (IFIM) (Trihey and Wegner 1981) in conjunction with the IFG-4 computer model (Milhous et al. 1984), meets this need and also provides the requisite physical and hydrologic data for evaluating plant species distributions in response to streamflow. To

procure vegetation data for analysis, a sampling method was devised for collecting information on species' distributions along IFIM transects (hereafter referred to as "belt transect sampling"). Two streams in the Sierra Nevada have been sampled to test the procedure.

## METHODS

### Study Site Location

Three reaches on the North Fork Kings River (NFKR) located on the west slope of the Sierra Nevada, California, were sampled during the summer of 1984. Three additional reaches on Bishop Creek on the east slope of the Sierra Nevada were sampled during the fall 1984. The NFKR is essentially an unregulated stream within the reaches sampled and it experiences periodic overbank flooding. Bishop Creek is regulated by dams and hydroelectric diversions which eliminate most flood peaks.

### Field Sampling

IFIM transects are placed in areas representing "characteristic" fish habitat conditions in a reach (Trihey and Wegner 1981). Topography along each transect is measured at small intervals (< 1 meter) using an engineer's transit and stadia rod. Streamflow measurements are made along the transect during three flows; usually the lowest and highest possible, and at intermediate discharge levels. The objective is to collect data for each transect to allow computerized calculations of roughness, velocity, and water surface elevations for discharges of various magnitudes. Simulation modeling establishes the elevation of the water across each transect at various streamflows. The method is further described in Trihey and Wegner (1981) and Milhous et al. (1984).

---

<sup>1</sup>Paper presented at the North American Riparian Conference. [Tucson, Arizona, April 16-18, 1985].

<sup>2</sup>Richard R. Harris is Assistant Professor of Plant and Earth Sciences, University of Wisconsin, River Falls, WI; Roland J. Risser is Biologist, Pacific Gas and Electric Company, San Ramon, CA; Carl A. Fox is Senior Research Scientist, Southern California Edison Company, Rosemead, CA.

Belt transect sampling over established IFIM transects was performed after floodplain topography had been surveyed. The rooted location of all plants on the floodplain was recorded within a belt 3 meters wide centered on the IFIM transect line. Plant positions were recorded as the cumulative distance from the starting point of the transect to the nearest 0.1 meter. These data established the position of each plant with respect to distance from the stream, elevation above the stream, and simulated discharge level.

On NFKR, only data on plant positions were collected. The sampling procedure was modified at Bishop Creek to collect auxiliary data on light (percent canopy closure over plants), rooting substrate, channel geometry and groundwater influence.

#### Analysis Procedures

To analyze species' distributions across all transects, the position of each plant was calculated as the proportional horizontal distance from the thalweg (lowest point of the stream channel bottom) to the end of the half-transect on which the plant occurs. Using multiple analysis of variance, each species distribution above and horizontally away from the thalweg was compared to that of all other species. The frequency distribution of each species by simulated discharge class was also evaluated.

Kolmogorov-Smirnov two sample tests (Sokal and Rohlf 1981) were used for the latter analysis under the null hypothesis of no significant differences between the species. Differences were considered significant at  $p < 0.01$ . The procedure for statistical analysis of environmental data from Bishop Creek (other than streamflow) has not yet been defined. Interested readers should contact the senior author for further information.

## RESULTS

### NFKR

Vegetation data were collected along 22 IFIM transects at NFKR. Occurrence patterns of the 12 most frequently encountered riparian species were analyzed. Statistical analysis confirmed three types of riparian plant distributions in relation to stream discharge on NFKR:

1. Species flooded infrequently, only at high discharge, and with a short duration. Rhododendron occidentale<sup>3</sup>, Fraxinus latifolia and Alnus rhombifolia represented this condition.

2. Species flooded at relatively low discharge, frequently and/or for a long duration. Juncus nevadensis, Carex spp. and Helenium Bigelovii represented this condition.
3. Species flooded at intermediate discharges or those whose bimodal distribution causes them to be flooded at both extremes. Six of the 12 species analyzed represented this condition.

The work at NFKR indicated that each of three different flooding environments had a characteristic complement of plant species. Within these environments, the effects of other environmental conditions on plant occurrence could not be evaluated because relevant data were not available at time of the analysis.

### Bishop Creek

A total of 60 IFIM transects were sampled on Bishop Creek. Analysis of plant species-discharge relationships indicated no differentiation of species by simulated discharge class. This may be a consequence of the fact that the modeled discharges were all within the channel banks and that plants dependent on streamflow were aggregated near the banks. Plants rooted at greater distances could not be directly affected by streamflow because no overbank discharges were modeled and none appeared to occur on this controlled stream.

These results led to an exploratory analysis of the data to determine the effects of other environmental factors on species' occurrence patterns. Although this analysis has not been completed, preliminary results indicate that some species were associated with specific environmental conditions. For example, Rosa woodsii and Populus tremuloides appear to be associated with incised channels. Artemisia tridentata, a dry land species, did not occur on transects where groundwater influence was evident. Other species appeared to be associated with specific light or substrate conditions.

To fully evaluate species' responses to environmental conditions at Bishop Creek, a multivariate analysis will be undertaken in the next phase of this research. For the present, it is tentatively concluded that within a specific zone of flooding effects or on controlled streams, plant species may differentiate along environmental gradients other than those associated with flooding.

## DISCUSSION

Alterations in instream flow often result from hydroelectric development. The effects of these alterations on riparian vegetation may be manifested in terms of changes in the distributions and characteristics of plant

<sup>3</sup> Nomenclature follows Munz (1975)

species on the floodplain. A study of existing diversions on headwater streams of the western Sierra Nevada disclosed two different general responses to diversion (Harris and Risser in preparation). Some streams were observed to have increased riparian species cover, apparently due to reduced destructive effects of flooding. Other streams were observed to have decreased riparian species cover, presumably due to induced soil moisture stress. Utilization of IFIM data allows an analysis of the directional response of plant species which may improve our understanding of overall vegetation effects.

The distribution of riparian plants can be interpreted as species' responses to ecological conditions within the floodplain. If it is assumed that flooding is the dominant controlling variable on unregulated streams, species most tolerant to flooding will be found in relatively high abundance in lower discharge classes. Areas closer to the thalweg are often too disturbed by flooding for most plants to survive in abundance (Menges and Waller in press; Harris 1985). Since lower discharges occur more frequently, these plants are flooded more often and for a relatively greater proportion of the year. These species may be adversely affected if streamflow is reduced in such a way that they are no longer flooded according to existing conditions. Their abundance may decline as a result of moisture stress, reduced reproductive potential, or invasion by more competitive species.

Some species are most frequently found in locations where flooding occurs only at higher discharges. These species appear the least tolerant of flooding. If streamflow is reduced, these species may increase in abundance by occupying formerly unfavorable habitats.

Species which have indistinct distributions in relation to discharge may be relatively insensitive, or may have equal sensitivity to flooding effects. Intermediate locations where these plants are located are subject to greater variability in both frequency and duration of flooding than either adjacent zone. Within the intermediate zone, rising and falling water levels result in constantly changing conditions for plant establishment. This may help explain the fact that intermediate locations have a greater number of plant species. Annually, as flooding flows occur, conditions within a given stream reach may change, creating optimal conditions for a different complement of species.

The effects of light, substrate, and root stratification may affect these generalizations. On controlled streams or within a specific zone of flooding effects, species may differentiate on the basis of light, substrate or other factors. Interactions among factors and compensatory mechanisms may exist and may affect responses of species to increases or decreases in streamflow. In future testing of this method these relationships will be studied more fully.

For impact assessment on streams proposed for diversion, two levels of vegetation data are required: 1) General habitat conditions need to be described (e.g. vegetation characteristics, substrate, gradient). This type of data may be obtained through extensive, rapid survey techniques. 2) Plant distribution vis-a-vis topography and discharge should be analyzed. Belt transect sampling is suitable for collection of this type of information.

An integrated instream resource inventory method would include both techniques. Rapid survey techniques could be used to generally characterize the riparian vegetation on a stream. Only vegetation data would be collected. Collection of topographic data could be reduced to classification of floodplain cross sections to allow later correlation with IFIM modeling results.

Belt transects should be situated to ensure sampling of the range of vegetation conditions found on streams. If properly located, the belt transects are adequate for evaluating occurrence patterns, density, and species diversity. The results can be used to predict impacts for the streamside vegetation as a whole.

#### ACKNOWLEDGMENTS

Dr. Robert F. Holland and Virginia Dains collected the field data used for this study. David Hanson, EA Engineering, Science, and Technology, Inc. and Thomas Lambert, Pacific Gas and Electric Company (PG&E) assisted in the interpretation of IFIM hydrologic modeling. Phillip Dunn, Jones & Stokes Associates, provided information on IFIM field techniques. Jordan Lang and JoAnne Sorenson (Jones & Stokes Associates) and Michael Fry (PG&E) provided helpful comments on drafts of the manuscript.

This research was financially supported by Pacific Gas and Electric Company and Southern California Edison Company.

#### LITERATURE CITED

- Bell, D. T. 1980. Gradient trends in the streamside forest of central Illinois. *Bulletin Torrey Botanical Club* 107:172-180.
- Hack, J. T., and J. C. Goodlet. 1960. *Geomorphology and forest ecology of a mountain region in the central Appalachians*. 66 p. U.S. Geological Survey Professional Paper 347.
- Harris, R. R. 1985. Relationships between fluvial geomorphology and vegetation on Cottonwood Creek, Tehama and Shasta Counties, California. Ph.D Dissertation. 329 p. University of California, Berkeley, CA.

- Harris, R. R. and R. J. Risser. In preparation. Characteristics of riparian vegetation at existing and proposed hydroelectric diversions in the western Sierra Nevada, California.
- Hupp, C. F. 1982. Stream-grade variation and riparian forest ecology along Passage Creek, Virginia. Bulletin Torrey Botanical Club 109:488-499.
- Menges, E. S. and D. M. Waller. In press. Plant strategies in relation to elevation and light in floodplain herbs. American Naturalist.
- Milhous, R. T., D. L. Wegner, and T. Waddle. 1984. Users guide to the physical habitat simulation system. Instream Flow Information Paper 11. U.S. Fish and Wildlife Service. FWS/OBS-81/43 (Revised).
- Munz, P. A., and D. D. Keck. 1975. A California flora and supplement. University of California Press, Berkeley, CA.
- Sokal, R. R., and F. J. Rohlf. 1981. Biometry. Second Edition. 776 p. W. H. Freeman and Company, New York, N.Y.
- Trihey, E. W., D. L. Wegner. 1981. Field data collection procedures for use with the physical habitat simulation system of the Instream Flow Group. U.S. Fish and Wildlife Service, Cooperative Instream Flow Service Group. 151 p. Fort Collins, CO

# A Stream Classification System<sup>1</sup>

DAVID L. ROSGEN<sup>2</sup>

---

Abstract.--A stream classification system is presented which categorizes various stream types by morphological characteristics. Delineation criteria are stream gradient, sinuosity, width/depth ratio, channel materials, entrenchment, confinement, and soil/landform features. Applications include riparian management guidelines, fisheries habitat interpretations, hydraulic geometry and sediment transport relationships.

---

## INTRODUCTION

It has long been a goal for individuals working with rivers to define and understand the processes which influence the pattern and character of river systems. Their differences as well as their similarities under diverse settings pose a real challenge for study. One consistent axiom associated with rivers is that what initially appears complex is even more so under further investigation.

Obviously, over-simplification of such complex systems may appear presumptuous. However, the need to categorize river systems by channel morphology is apparent for the following reasons: 1) the need to predict a river's behavior from its appearance; 2) the need to extrapolate specific data collected on a given river reach to another of similar character and; 3) the need to provide a consistent and reproducible frame of reference for those working with river systems.

## Stream Classification

The effort to classify streams is not new. Davis (1899) first divided rivers into three stages; youthful, mature, and old age. Thornbury (1969) developed a system based on stream development in various valley types. Patterns were described as antecedent, superposed, consequent, and subsequent. The delineative criteria of these early classification systems required qualitative geomorphic interpretations creating delineative inconsistencies.

Straight, meandering, and braided patterns were described by Leopold and Wolman (1957). Lane (1957) developed quantitative slope-discharge relationships for braided, intermediate, and meandering streams. Khan (1971) similarly related sinuosity, slope, and channel pattern for sand bed channels.

One of the more popular classification schemes was developed by Schumm (1963). Delineation is based on channel stability (stable, eroding, or depositing) and mode of sediment transport (mixed load, suspended load, and bedload). Applications of this procedure have been used on Canadian Rivers by Mollard (1973). Other classification schemes have been developed by Melton (1935), Matthes (1956), Galay et al. (1973), and Kellerhals et al. (1972). A descriptive classification was also developed by Culbertson et al., (1967) which utilized depositional features, vegetation, braiding patterns, sinuosity, meander scrolls, bank heights, levee formations, and floodplain types.

With certain limitations most of these classification systems met the objectives of their design. However, the requirement for more detailed, reproducible, quantitative applications in wildland hydrology led to the development of the classification system presented here.

## Stream Classification Criteria

The purpose of this classification scheme is to categorize natural stream channels on the basis of measurable morphological features. Thus, consistent and reproducible descriptions and interpretations can be readily obtained over a wide range of hydrophysiographic regimes.

There are many observable stream channel features governed by the laws of physics which operate to form the morphology of the present day channel. Stream morphology and related channel patterns are directly influenced by eight major variables including width, depth, velocity,

---

<sup>1</sup>Paper presented at the symposium, Riparian Ecosystems and Their Management: Reconciling Conflicting Uses, April 16-18, Tucson, Arizona.

<sup>2</sup>Hydrologist, U.S. Forest Service, Fort Collins, Colo.

discharge, slope, roughness of channel materials sediment load and sediment size (Leopold et al. 1964). A change in any one of these variables sets up a series of concurrent changes in the others, resulting in altered channel patterns. Since stream morphology is a result of an integrative process of mutually adjusting variables, those most directly measurable have been incorporated into the delineative criteria for stream types. Selection of the delineative criteria for stream classification was developed from detailed analysis of hundreds of streams over many hydrophysiographic regions and from portions of existing classification schemes.

The stream type classification is summarized in detail in Table 1 and includes the following criteria; channel gradient (measured as energy slope of the water surface); sinuosity (ratio of channel length to valley length); width/depth ratio (width at bankful stage divided by bankful depth); dominant particle size of bed and bank materials; entrenchment of channel and confinement of channel in valley; and landform features, soil erodibility, and stability.

Estuarine streams are also classified utilizing a system developed by Fisher et al. (1969). This classification scheme describes delta types on the basis of deltaic sequences. Four major types are identified; high-constructive lobate; high constructive elongate; high-destructive, tide dominated; and high-destructive, wave dominated deltas (Table 2).

Streams incised in a mixture of glacial ice and inorganic debris are also classified (Table 2).

Data from glacial and estuarine stream types are limited. Therefore, detailed channel morphology needs field verification for further description.

Table 2.--Estuarine and Glacial Stream Types.

Estuarine Streams (Deltas)

- E1. High Constructive - Lobate shaped deltas with a wide, well defined delta plain and numerous distributary channels.
- E2. High Constructive - Elongate deltas with a narrow delta plain with lateral distributary channels.
- E3. High Destructive - Tide dominated deltas.
- E4. High Destructive - Wave dominated deltas.

Glacial Streams

- G1. Streams incised in glacial ice with mixture of tills involving coarse textured materials including small boulders, cobble, gravels, sands, and some silt.
- G2. Streams incised in glacial ice with materials of silts, clays, and some sands. Typical of glacio-lacustrine deposits.

Table 1.-- Criteria for Stream Types.

STREAM TYPE	GRADIENT	SINUOSITY	W/D RATIO	DOMINANT PARTICLE SIZE OF CHANNEL MATERIALS	CHANNEL ENTRENCHMENT- VALLEY CONFINEMENT	LANDFORM FEATURE - SOILS/STABILITY
A1	4-10	1.0-1.1	10 or less	Bedrock.	Very deep/very well confined.	Deeply incised bedrock drainageway w/ steep side slopes and/or vertical rock walls.
A1-a	10 +	(Criteria	same as	A1)		
A2	4-10	1.1-1.2	10 or less	Large & small boulders w/mixed cobble.	Same	Steep side slopes w/predominantly stable materials.
A2-a	10 +	(Criteria	same as	A2)		
A3	4-10	1.1-1.3	10 or less	Small boulders, cobble, coarse gravel.	Same	Steep, depositional features w/predominantly coarse textured soils. Debris avalanche is the predominant erosional process. Stream adjacent slopes are rejuvenated with extensive exposed mineral soil.
A3-a	10 +	(Criteria	same as	A3)		
A4	4-10	1.2-1.4	10 or less	Predominantly gravel, sand, and some silts.	Same	Steep side slopes w/mixture of either depositional landforms with fine textured soils such as glaciofluvial or glaciolacustrine deposits or highly erodable residual soils such as grussic granite, etc. Slump-earthflow and debris avalanche are dominant erosional processes. Stream adjacent slopes are rejuvenated.
A4-a	10 +	(Criteria	same as	A4)		
A5	4-10	1.2-1.4	10 or less	Silt and/or clay bed and bank materials.	Same	Moderate to steep side slopes. Fine textured cohesive soils, slump-earthflow erosional processes dominate.
A5-a	10 +	(Criteria	same as	A5)		



STREAM TYPE	GRADIENT %	SINUOSITY	W/D RATIO	DOMINANT PARTICLE SIZE OF CHANNEL MATERIALS	CHANNEL ENTRENCHMENT-VALLEY CONFINEMENT	LANDFORM FEATURE - SOILS/STABILITY
B1-1	1.5-4.0	1.3-1.9	10 or greater ( $\bar{X}$ :15)	Bedrock bed, banks, cobble, gravel, some sand.	Shallow entrenchment. Moderate confinement.	Bedrock controlled channel with coarse textured depositional bank materials.
B1	2.5-4.0 ( $\bar{X}$ :3.5)	1.2-1.3	5-15 ( $\bar{X}$ :10)	Predominantly small boulders, very large cobble.	Moderately entrenched/well confined.	Moderately stable, coarse textured resistant soil materials. Some coarse river terraces.
B2	1.5-2.5 ( $\bar{X}$ :2.0)	1.3-1.5	8-20 ( $\bar{X}$ :14)	Large cobble mixed w/ small boulders & coarse gravel.	Mod. entrenched/Mod. confined.	Coarse textured, alluvial terraces with stable, moderately steep, side slopes.
B3	1.5-4.0 ( $\bar{X}$ :2.5)	1.3-1.7	8-20 ( $\bar{X}$ :12)	Cobble bed w/ mixture of gravel & sand - some small boulders.	Mod. entrenched/well confined.	Glacial outwash terraces and/or rejuvenated slopes. Unstable, moderate to steep slopes. Unconsolidated, coarse textured unstable banks. Depositional landforms.
B4	1.5-4.0 ( $\bar{X}$ :2.0)	1.5-1.7	8-20 ( $\bar{X}$ :10)	Very coarse gravel w/ cobble mixed sand and finer material.	Deeply entrenched/well confined.	Relatively fine river terraces. Unconsolidated coarse to fine depositional material. Steep side slopes. Highly unstable banks.
B5	1.5-4.0 ( $\bar{X}$ :2.5)	1.5-2.0	8-25 ( $\bar{X}$ :15)	Silt/clay.	Same	Cohesive fine textured soils. Slump-earthflow erosional processes.
C1-1	1.5 or less ( $\bar{X}$ :1.0)	1.5-2.5	10 or greater ( $\bar{X}$ :30)	Bedrock bed, gravel, sand, or finer banks.	Shallow entrenchment, poorly confined.	Bedrock controlled channel with depositional fine grained bank material.
C1	1.2-1.5 ( $\bar{X}$ :1.3)	1.5-2.0	10 or greater ( $\bar{X}$ :18)	Cobble bed with mixture of small boulders and coarse gravel.	Mod. entrenched/Mod. confined.	Predominantly coarse textured, stable high alluvial terraces.
C2	0.3-1.0 ( $\bar{X}$ :0.6)	1.3-1.5	15-30 ( $\bar{X}$ :20)	Large cobble bed w/ mixture of small boulders & coarse gravel.	Mod. entrenched/well confined.	Overfit channel, deeply incised in coarse alluvial terraces and/or depositional features.
C3	0.5-1.0 ( $\bar{X}$ :0.8)	1.8-2.4	10 or greater ( $\bar{X}$ :22)	Gravel bed w/mixture of small cobble & sand.	Mod. entrenched/slight confined.	Predominantly moderate to fine textured multiple low river terraces. Unstable banks, unconsolidated, noncohesive soils.
C4	0.1-0.5 ( $\bar{X}$ :0.3)	2.5 +	5 or greater ( $\bar{X}$ :25)	Sand bed w/mixtures of gravel & silt (no bed armor).	Mod. entrenched/slight confined.	Predominantly fine textured, alluvium with low flood terraces.
C5	0.1 or less ( $\bar{X}$ :.05)	2.5 +	5 or greater ( $\bar{X}$ :10)	Silt/clay w/mixtures of medium to fine sands (no bed armor).	Mod. entrenched/slight confined.	Low, fine textured alluvial terraces. delta deposits, lacustrine, loess or other fine textured soils. Predominantly cohesive soils.
C6	0.1 or less ( $\bar{X}$ :.05)	2.5 +	3 or greater ( $\bar{X}$ :5)	Sand bed w/mixture of silt & some gravel.	Deep entrenched/slight confined.	Same as C4 except has more resistant banks.
D1	1.5 or greater ( $\bar{X}$ :2.5)	N/A Braided	N/A	Cobble Bed w/mixture of coarse gravel & sand & small boulders.	Slight entrenched/no confinement.	Glacial outwash, coarse depositional material, highly erodable. Excess sediment supply of coarse size material.
D2	1.5 or less ( $\bar{X}$ :1.0)	N/A Braided	N/A	Sand bed w/mixture of small to medium gravel & silts.	Slight entrenched/no confinement.	Fine textured depositional soils, very erodable - excess of fine textured sediment.

### Stream Sub-type Classification

Observations have indicated that over time major stream types can be altered in their pattern and associated response and feedback mechanisms by various influences. These influences can change specific factors of

fisheries habitat, sediment supply, channel stability, etc. These influences have been grouped into a series of physical characteristics used to delineate stream sub-types (Table 3). The stream sub-type criteria are: 1) riparian vegetation; 2) Organic debris and/or channel blockages, 3) stream size (width), 4) flow regimen

Table 3.--Stream Sub-type Criteria

<p style="text-align: center;">ORGANIC DEBRIS/Channel Blockages (in Active Channel)</p> <p>D-1 None</p> <p>D-2 Infrequent debris, what's present consists of small, floatable organic debris.</p> <p>D-3 Moderate frequency, mixture of small to medium size debris affects less than 10% of active channel area.</p> <p>D-4 Numerous debris mixture of medium to large sizes - affecting up to 30% of the area of the active channel.</p> <p>D-5 Debris dams of predominantly large material affecting over 30% to 50% the channel area and often occupying the total width of the active channel.</p> <p>D-6 Extensive, large debris dams either continuous or influencing over 50% of channel area. Forces water onto flood plain even with moderate flows. Generally presents a fish migration blockage.</p> <p>D-7 Beaver dams. Few and/or infrequent. Spacing allows for normal streamflow conditions between dams.</p> <p>D-8 Beaver dams - Frequent. Back water occurs between dams - stream flow velocities reduced between dams.</p> <p>D-9 Beaver dams - abandoned where numerous dams have filled in with sediment and are causing channel adjustments of lateral migration, evulsion, and degradation etc.</p> <p>D-10 Man made structures - diversion dams, low dams, controlled by-pass channels, baffled bed configuration with gabions, etc.</p>	<p style="text-align: center;">RIPARIAN VEGETATION</p> <p>V1 - Rock</p> <p>V2 - Bare soil, little to no-vegetative cover</p> <p>V3 - Annuals, forbs</p> <p>V4 - Grass - perennial bunch grasses</p> <p>V5 - Grass - sod formers</p> <p>V6 - Low brush species</p> <p>V7 - High brush species</p> <p>V8 - Coniferous trees</p> <p>V9 - Deciduous trees</p> <p>V10 - Wetlands</p> <p style="margin-left: 40px;">a. bog b. fen c. marsh</p> <p>Note: Combinations of grass and brush understories with a coniferous overstory can be designated by combining sub type numbers, i.e., (V4,7,8.)</p> <p>Subscript letters may be used to identify specific vegetative associations, speciation, habitat types, or riparian types based on level of detail required by stream type user.</p>
<p style="text-align: center;">STREAM SIZE (S)</p> <p>S-1 Bankfull width less than 1 foot.</p> <p>S-2 Bankfull width 1-5.</p> <p>S-3 Bankfull width 5-15.</p> <p>S-4 Bankfull width 15-30.</p> <p>S-5 Bankfull width 30-50.</p> <p>S-6 Bankfull width 50-75.</p> <p>S-7 Bankfull width 75-100.</p> <p>S-8 Bankfull width 100-150.</p> <p>S-9 Bankfull width 150-250.</p> <p>S-10 Bankfull width 250-350.</p> <p>S-11 Bankfull width 350-500.</p> <p>S-12 Bankfull width 500-1000.</p> <p>S-13 Bankfull width 1000+.</p>	<p style="text-align: center;">FLOW REGIMEN</p> <p><u>General Category</u></p> <p>E. - Ephemeral stream channels - flows only in response to precipitation.</p> <p>S. - Subterranean stream channel - flows parallel to and near the surface for various seasons - a sub-surface flow which follows the stream channel bed.</p> <p>I. - Intermittent stream channel - one which flows only seasonally, or sporadically. Surface sources involve springs, snow melt, artificial controls, etc.</p> <p>P. - Perennial stream channels. Surface water persists year long.</p> <p><u>Specific Category</u></p> <ol style="list-style-type: none"> <li>1. Seasonal variation in streamflow dominated primarily by snowmelt runoff.</li> <li>2. Seasonal variation in streamflow dominated primarily by stormflow runoff.</li> <li>3. Uniform stage and associated streamflow due to spring fed condition, backwater etc.</li> <li>4. Stream flow regulated by glacial melt.</li> <li>5. Regulated stream flow due to diversions, dam release, dewatering, etc.</li> </ol>
<p style="text-align: center;">DEPOSITIONAL FEATURES (BARS)</p> <p>B-1 Point Bars</p> <p>B-2 Point Bars with Few Mid Channel Bars</p> <p>B-3 Many Mid Channel Bars</p> <p>B-4 Side Bars</p> <p>B-5 Diagonal Bars</p> <p>B-6 Main Branching with Many Mid Bars and Islands</p> <p>B-7 Mixed Side Bar and Mid Channel Bars Exceeding 2-3X Width</p> <p>B-8 Delta Bars</p>	<p style="text-align: center;">MEANDER PATTERNS</p> <p>M-1 Regular Meander</p> <p>M-2 Tortuous Meander</p> <p>M-3 Irregular Meander</p> <p>M-4 Truncated Meanders</p> <p>M-5 Unconfined Meander Scrolls</p> <p>M-6 Confined Meander Scrolls</p> <p>M-7 Distorted Meander Loops</p> <p>M-8 Irregular with Oxbows, Oxbow Cutoffs</p>

(perennial, ephemeral, subterranean, intermittent channels, streamflow variations and sources; stormflow, snowmelt, glacial fed, etc.), 5) depositional features, and 6) meander patterns.

As with the major stream types, these sub-types can be determined primarily from aerial photographs and topographic maps. The advantage of this more detailed sub-type delineation provides for higher resolution of interpretations while providing more flexibility for multiple applications.

#### Procedural Applications

The classification scheme is applicable only to certain river reaches as the river character can change in relatively short distances due to shifts in channel gradient, materials, entrenchment, etc. The stream typing is designed to be accomplished by use of aerial photographs and topographic maps. Field checking, however, is important as the actual gradients, dominant particle sizes and width/depth ratios can be validated for each major stream type.

There are various appropriate levels of applications. For some, only the major stream type delineation would be required. For others, however, stream sub-types may provide the needed resolution for consistent interpretations. This particular classification has been in use since 1978 for various applications including:

- 1) Development of minimum standards and guidelines for riparian areas;
- 2) establishment of sediment threshold limits for water yield models and soil loss-sediment supply evaluations;
- 3) development of hydraulic geometry  $y$ , relationships correlating discharge with width, depth, velocity slope, and cross-sectional area;
- 4) development of roughness coefficients for engineering calculations; and
- 5) relationships and coefficients for applications of tractive force equations;
- 6) establishing ratios of bedload to suspended load, nature, and size of sediment transport and sediment rating curves;
- 7) streampower/bedload transport rate relationships;
- 8) fisheries habitat interpretations;
- 9) fisheries habitat structural improvement guidelines;
- 10) channel stability relationships;
- 11) debris management guidelines;
- 12) stream restoration guidelines, and
- 13) direct linkage with land systems inventory and analysis.

#### SUMMARY

The development of a quantitative stream classification system utilizing channel morphological indices provides for some consistency in defining stream types for potential universal applications. The system has a multitude of applications for various purposes involving stream systems. This may be the first approximation of a system which will be refined over the years, as our knowledge and

experience continues to fill in the narrowing gaps. It hopefully can be a vehicle to provide better communication between those studying riparian systems to promote a better understanding of river processes.

#### LITERATURE CITED

- Culbertson, D. M., L. E. Young, and J. C. Brice. 1967. Scour and fill in Alluvial Channels, U.S. Geological Survey, Open File Report.
- Davis, W. M. 1899. The Geographical Cycle, *Geographical Journal*, Vol. 14, pp. 481-504.
- Fisher, W. L., L. F. Brown Jr., A. J. Scott, and J. H. McGowen. 1969. Delta Systems in the exploration for oil and gas, a research colloquium: Bur. Econ. Geol. Univ. of Texas at Austin.
- Galay, V. J., R. Kellerhals, and D. I. Bray. 1973. Diversity of river types in Canada in *Fluvial Process and Sedimentation: Proc. of Hydrology Symposium: National Research Council of Canada*, p. 217-250.
- Kellerhals, R., C. R. Neill, and D. I. Bray. 1972. Hydraulic and geomorphic characteristics of rivers in Alberta: Research Council of Alberta, River Engineering and Surface Hydrology Report 72-1, 52 p.
- Khan, Hamidur, R. 1971. Laboratory Studies of Alluvial River Channel Patterns, Ph.D. Dissertation, Civil Engineering Department, Colorado State Univ., Fort Collins, Colo.
- Land, E. W. 1957. A Study of the Shape of Channels Formed by Natural Streams Flowing in Erodible Material, Missouri River Division Sediment Series No. 9, U.S. Army Engineer Division, Missouri River, Corps of Engineers, Omaha, Nebraska.
- Leopold, L. B., and M. G. Wolman. 1957. River channel patterns; braided, meandering, and straight: U.S. Geol. Surv. Prof. Paper 282-B.
- Leopold, L. B., M. G. Wolman, and J. P. Miller. 1964. *Fluvial Processes in Geomorphology*: Freeman, San Francisco, Calif. 522 pp.
- Matthes, G. 1956. "River Engineering" Chap. 15. *American Civil Engineering Practice.*, Abbott (editor), John Wiley and Sons.
- Melton, F. A. 1935. An Empirical Classification of Floodplain Stream: *Geographical Review*. Volume 26.
- Mollard, J. D. 1973. Air photo interpretation of fluvial features: in *Fluvial processes and sedimentation: Research Council of Canada*, p. 341-380.
- Schumm, S. A. 1963. A Tentative Classification of Alluvial River Channels, U.S. Geological Survey Circular 477. Wash. D.C.
- Thornbury, W. D. 1969. *Principles of Geomorphology*, 2nd Edition, John Wiley and Sons.

# The Importance of Riparian Habitats for the Conservation of Endangered Mammals in Mexico<sup>1</sup>

Gerardo Ceballos-G<sup>2</sup>

-----  
ABSTRACT.- An analysis of the status of endangered mammals from Mexico is presented. 47 species are threatened with extinction. Seven (one aquatic and six semiaquatic ones) are confined to riverine ecosystems. The increasing exploitation of their populations and the destruction of riparian habitats is the main threat for the long-term survival of those species.  
-----

## INTRODUCTION

Conservation biology and ecology confront a staggering increase in the number of extinct and endangered species in recent times. In the last four centuries at least 226 species of vertebrates have become extinct (Allen 1942, Greenway 1958, King 1981). Estimates of current extinction rates are close to one species per day (Myers 1984). If these rates continue to increase, it is probable that one million species will be lost by the end of the century (Myers 1984).

Why are so many species being lost at such devastating rates? What is the impact of these massive extinctions in natural ecosystems? Present mammal related extinctions are caused by the rapid ecological changes resulting from direct and indirect human activities. Species are exterminated by exploitation (e.g. hunting) and qualitative and quantitative changes of the environment (e.g. habitat destruction) (Allen 1942, Diamond 1984, Simon and Geroudent 1970).

Exploitation differs from other factors affecting the environment by the scale and degree of its effects in natural ecosystems. On the one hand, species tend to be exploited because they have certain characteristics that make them valuable or undesired. Indeed, man has proven to be very successful in exterminating many populations and species of organisms that fall in any of these categories. The process is, however, species-specific. On the other hand, factors affecting qualitative and quantitative aspects of the environment, tend to be very unselective. Many species are affected at the same time.

The destruction of habitats and ecosystems is increasing every day. It is not surprising that this is one of the main cause of extinction. Deforestation, urbanization, agriculture and other development-related factors impose increasing pressures on natural ecosystems, many of which are extremely susceptible to degradation. Tropical, arid and riv-

erine ecosystems are particularly fragile (Gomez-Pompa et al 1972, Miller 1961, Rea 1983).

In this paper I discuss the degradation of riparian habitats and its consequences for the conservation of endangered mammals in Mexico. I emphasize the historical changes in the distribution of several species restricted to those habitats.

## RIPARIAN HABITATS IN MEXICO

Riparian habitats are widely distributed in Mexico, being important components of temperate and tropical ecosystems (Rzedowski 1978). These habitats develop along the rivers' margins, and are surrounded by drier vegetation. Riparian habitats are the ecotone between aquatic and terrestrial ecosystems. They differ in their vegetation diversity, heterogeneity, composition and productivity from adjacent areas (Johnson, Haight and Simpson 1977). The strongest contrasts are found in arid lands, where water is a limiting resource. However, riparian habitats also differ from adjacent habitats in mesic temperate and tropical regions (Rzedowski 1978).

The characteristics of riparian habitats make them unique, with a rich plant and animal life. These habitats provide many species of vertebrates with refuges, shelter and food, and usually, with abundant water. Riparian habitats and riverine ecosystems also act as biogeographic dispersal barriers and corridors (e.g. Boeer and Schmidly 1977).

In Mexico riverine ecosystems have been greatly degraded. Developmental expansion has resulted in profound changes in all the large rivers of the country. Reduction of stream flow, grazing, pollution, salination, siltation, dissipation and removal of plant cover are some of the main problems changing the face of riverine ecosystems. A dramatic example is the Lerma river, which water is used to supply Mexico city. Presently, the river flow is almost non-existent and the water is highly pollu-

<sup>1</sup> Paper presented at the First North American Riparian Conference. (University of Arizona, Tucson, April 16-18, 1985).

<sup>2</sup> Gerardo Ceballos-G, Department of Ecology and Evolutionary Biology, University of Arizona, Tucson, AZ., 85721, USA.

ted by chemical wastes from a nearby industrial park. The marshes and willow trees that used to grow along the river banks, have practically disappeared. The marshes were important wintering grounds for waterfowl in central Mexico. A few endemic species of vertebrates are critically endangered, and at least one, the slender-beaked grackle (Quiscalus palustris) is extinct (King 1983).

The problem of degradation of riverine ecosystems is particularly severe in arid regions of northern Mexico, where the main rivers have been seriously altered, increasing desertification and causing the extinction of some freshwater fishes (Contreras-Balderas 1978). In central and southern Mexico the situation is similar; the main problems are land use and water pollution.

Even though the degradation of riparian habitats have been extensive, there are still areas in which riverine ecosystems are unspoiled. Many pristine ecosystems are found in very inaccessible areas. Some of these areas represent the last stronghold for populations of several endangered mammals.

#### MEXICAN EXTINCT AND ENDANGERED MAMMALS

An analysis of the conservation status of Mexican mammals revealed that, at least, 47 species are endangered and five have become extinct since 1850 (Table 1). Seven of these endangered species are confined to riparian habitats.

Table 1.-- Extinct and endangered mammals from Mexico. The status (En= endangered or Ex= Extinct) and the cause of extinction (O= exploitation, H= habitat destruction, U= unknown) for each species are mentioned. For extinct species the year of last record of occurrence is also given. Species confined to riparian habitats are marked with an asterisk (\*).

Species	Status	Causes
<u>Alouatta palliata</u>	En	H,O
<u>Alouatta pigra</u>	En	H,O
<u>Antilocapra americana</u>	En	O,H
<u>Arctocephalus townsendii</u>	En	O
<u>Ateles geoffroyi</u>	En	H,O
<u>Bison bison</u>	EX 1900?	O
<u>Canis lupus</u>	En	O,H
<u>Castor canadensis</u> *	En	H,O
<u>Cervus canadensis</u>	En	O
<u>Chironectens minimus</u> *	En	H
<u>Cynomys ludovicianus</u>	En	H
<u>Cynomys mexicanus</u>	En	H
<u>Eira barbara</u>	En	H,O
<u>Enhydra lutris</u>	EX 1912	O
<u>Erethizon dorsatum</u>	En	H,O
<u>Eschrichtius robustus</u>	En	O
<u>Felis concolor</u>	En	O,H
<u>Felis onca</u>	En	O,H
<u>Felis pardalis</u>	En	O,H
<u>Felis weidii</u>	En	O,H
<u>Felis yagouaroundi</u>	En	O,H
<u>Galictis vittata</u>	En	H,O
<u>Lepus flavigularis</u>	En	H,O

<u>Lutra longicaudis</u> *	En	H,O
<u>Mazama americana</u>	En	H,O
<u>Mirounga angustirostris</u>	En	O
<u>Monachus tropicalis</u>	EX 1962	O
<u>Nasua nelsoni</u>	En	H
<u>Odocoileus hemionus</u>	En	O,H
<u>Ondatra zibethicus</u> *	En	H
<u>Ovis canadensis</u>	En	O,H
<u>Peromyscus pembertonii</u>	EX 1931	U
<u>Phoca vitulina</u>	En	H
<u>Procyon pygmaeus</u>	En	H,O
<u>Rheomys mexicanus</u> *	En	H
<u>Romerolagus diazi</u>	En	H,O
<u>Sylvilagus insonus</u>	En	H,O
<u>Tapirus bairdii</u> *	En	H,O
<u>Tayassu peccari</u>	En	H,O
<u>Taxidea taxus</u>	En	H,O
<u>Trichechus manatus</u> *	En	H,O
<u>Ursus arctos</u>	EX 1962	O,H
<u>Ursus americanus</u>	En	O,H
<u>Vampyrum spectrum</u>	En	H
<u>Vulpes macrotis</u>	En	H,O
<u>Zalophus californicus</u>	En	O

Are Riparian species more prone to extinction than other mammals?

The characteristics of endangered and extinct species of mammals from Mexico follow similar trends to those observed in other geographic areas. Species tend to be more prone to extinction with: 1) increasing body size, specialization and trophic level, and 2) decreasing population size, and area of distribution (Brown and Gibson 1983, Ceballos and Navarro 1985, Diamond 1984).

Most species of mammals confined to riparian habitats are endangered. These species are very susceptible to extinction because they tend to have small geographic distributions, low population densities, highly specialize habitat and feeding requirements, and to be restricted to very fragile ecosystems.

#### TEMPERATE MAMMALS

Beaver and Muskrat

Two species of semiaquatic temperate mammals are critically endangered in Mexico: the beaver (Castor canadensis) and the muskrat (Ondatra zibethicus). Both species have distributions restricted to the Colorado river in the Sonora-Baja California border, and to the Rio Bravo and its tributaries (figs. 1,2).

The present status of the population of muskrat is unknown; however, they still survive in low numbers.

Beaver was once abundant in Mexico; however, intense trapping depleted its populations (Leopold 1965). In recent decades beaver has also been threatened by encroachment on their habitat, by agriculture and ranching. The populations of northern Sonora, in the San Pedro river, have become extinct. The status of the species in the delta of the Colorado river is unknown, but it is probably very scarce. In the Rio Bravo and its tribu-

taries, beaver has survived better (Bernal 1978, Leopold 1965). In Nuevo Leon, an estimate of the population size was 256 individuals, distributed along 860 km of riverine ecosystems (Table 2) (Bernal 1978)

Table 2.-- Number of individuals and beaver colonies in Nuevo Leon, Mexico (from Bernal 1978).

RIVER	Km	Colonies	Individuals
Salado	135	19	76
San Juan	180	18	72
Alamo	60	13	52
Sabinas	120	5	20
Pilon	80	3	12
Agualeguas	30	2	8
Del Macho	15	2	8
Mohinos	70	1	4
Lobo	55	1	4
Other	115	0	0
<b>TOTAL</b>	<b>860</b>	<b>64</b>	<b>256</b>

These estimates show how critical the situation is for this species in Mexico. Very likely, there are less than 1000 individuals in the country.

#### TROPICAL MAMMALS

Five species of neotropical mammals restricted to riparian habitats are endangered in Mexico. The main problem faced by all of them is the destruction of their habitat. The tropical forests of the country have disappeared at an astonishing rate; if the present destruction continues, the last remnant of tropical evergreen forest will be lost within the next 10 years.

#### Manatee

Manatee (*Trichechus manatus*) is the only totally aquatic freshwater mammal in Mexico. They were widely distributed along the Gulf of Mexico and the Caribbean sea, from Tamaulipas to the Yucatan Peninsula (Hall 1981). Populations of manatee were hunted to extermination in many areas, and their habitat destroyed or polluted (e.g. Rio Coatzacoalcos, Veracruz). Presently, the whole population in Mexico probably does not exceed a few hundred individuals scattered along rivers and lagoons in Tabasco, Chiapas, Yucatan, Campeche and Quintana Roo (Villa and Colmenero 1982, Gallo 1982) (fig. 1).

#### Rheomys and Chironectens

Two species, *Rheomys mexicanus* and *Chironectens minimus*, are endangered exclusively by the loss of their habitat. *Rheomys* is a small rat, endemic to Oaxaca. It lives in the banks of a few rivers and streams, feeding on aquatic insects and small fishes (fig. 1).

*Chironectens* is a semiaquatic marsupial found along rivers in the tropical evergreen forest

(fig. 1). Population of this species have low densities, and they seem to very very susceptible to perturbations. So far this species is known from a few localities in Oaxaca (one), Tabasco (two) and Chiapas (several).



Figure 1.- Present (close symbols) and past (open symbols) distribution of beaver (circles), manatee (squares) and *Rheomys* (triangles) in Mexico.

#### Tapir

Tapir (*Tapirus bairdii*) is distributed from Veracruz to Chiapas and the Yucatan Peninsula (fig. 2) (Hall 1981, Leopold 1965). The species has been exterminated throughout most of its range, surviving in isolated localities in Quintana Roo, Chiapas and, probably, Oaxaca.

The populations' status of tapir in Mexico is little known. There is information about a few individuals in Quintana Roo (close to Belize), Chiapas (Lacandona forest), and there are unconfirmed records from Oaxaca (Chimalapa). The demise of the species has been closely associated to habitat destruction. In newly colonized areas, tapir is one of the first species to disappear. The future for the species is uncertain. If the few populations surviving are not protected immediately, they will vanish during the next 20 years.

#### River Otter

River otters (*Lutra longicaudis*) are still widespread in the tropical lowlands of Mexico (fig. 2). The densities are, in most of its range, very low. The species has been able to cope with the destruction of its habitat, mainly because of its dispersal abilities and broad feeding habits (fishes and aquatic invertebrates). It is probable that if the degradation of natural habitats continues at the same scale, river otters will be the last, of the seven mammals here mentioned, to disappear.

It is probable that another species of river otter, *Lutra canadensis*, is extinct in Mexico.

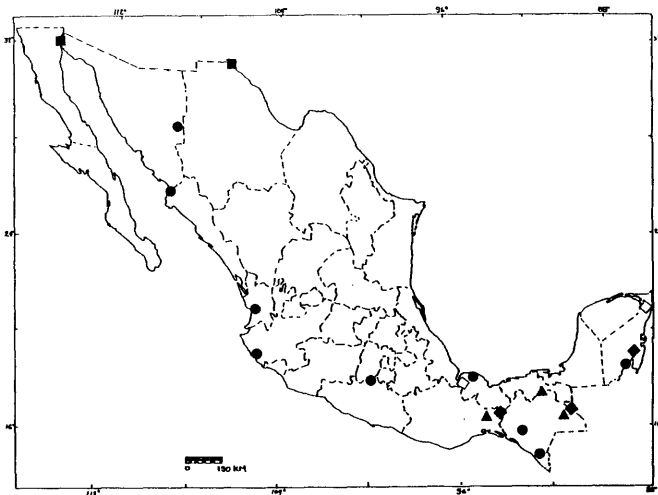

Figure 2.- Present (close symbols) and past (open symbols) distribution of muskrat (squares), river otter (circles), *Chironectes* (triangles), and tapir (diamonds) in Mexico.

#### DISCUSSION

Riverine ecosystems have been extensively degraded in Mexico. The populations of several species of mammals which distribution is restricted to riparian habitats have sharply declined in recent years. Important reasons for their decline have been overkilling and the destruction of their habitat. Other Mexican mammals are threatened by similar problems (Ceballos and Navarro 1985).

The ecological consequences of the extinction of riparian mammals are little known. However, some species play key roles in riparian communities. For instance, beaver is a key species in riverine ecosystems because its dams create freshwater ponds that are used by many organisms (Hill 1982). Several species of fishes are endangered in southwestern USA and northern Mexico because the loss of their habitats, which has often been linked to the disappearance of beaver (e.g. San Pedro River) (Miller 1961).

Another example is the role of manatees in limiting the population growth of aquatic plants. In southern Mexico the control of aquatic hyacinth (*Eichornia crassipes*), is an increasing problem. This aquatic angiosperm was accidentally introduced from South America. It rapidly invaded all kind of aquatic habitats, changing their physical conditions (e.g. oxygen concentration). Manatees are a natural option to control this plant.

Riverine ecosystems are unique in their biotas. Bird studies in USA have documented that the highest breeding densities of North American land birds are found in southwestern riparian habitats (Carothers, Johnson and Aitchison 1974). In Mexico the decline of tree ducks (*Dendrocygna* spp) and muscovy ducks (*Cairina moschata*) is associated to the loss of riparian habitats. Both species nest in trees, and are susceptible to changes in the availability of nesting sites (e.g. Rangel and Bolen 1984).

Pollution, dissipation, and other physical changes in riverine ecosystems have a profound

impact on aquatic organisms. Dozens of fishes are endangered in northern Mexico, especially by modifications to their habitats (Contreras-Balderas 1978). Several species are known from one or few localities (e.g. *Prietella phreatophila*), and at least one, *Stypodon signifer*, is extinct. The same is true for amphibians and aquatic reptiles. For instance, habitat modifications caused the extinction of *Sternotherus odoratus*, a turtle known in one locality in Mexico (Smith and Smith 1979).

It is important to emphasize that the conservation and rational management of riparian habitats in Mexico will ensure the survival of many species of plants and animals, and the perpetuation of unique and yet little biologically known ecosystems.

#### ACKNOWLEDGMENTS

I would like to thank Daniel Navarro, Roy Johnson and John R. Hendrickson for continuous stimulus. A. Ellinor Michel provided important comments on the manuscript. This study was financially supported by the National University of Mexico (UNAM).

#### LITERATURE CITED

- Allen, G.M. 1942. Extinct and vanishing mammals of the Western Hemisphere with the marine species of all the oceans. Spec. Publ. Amer. Comm. Int. Wildlife Protection 11: 1-620.
- Bernal, J.A. 1978. Estado actual del castor, *Castor canadensis* V. Bailey 1913, en el estado de Nuevo Leon, Mexico. Unpublished thesis, Facultad de Ciencias Biologicas, Universidad Autonoma de Nuevo Leon, Mexico.
- Boer, W.J. and D.J. Schmidly. 1977. Terrestrial mammals of the riparian corridor in the Big Bend National Park. p.212-219. In Importance, Preservation and Management of riparian habitat: a Symposium. (Tucson, Arizona., July 9, 1977) USDA Forest Service General Technical Report RM-43. Rocky Mountain Forest and Range Station, Fort Collins, Colo.
- Brown, J.H. and A.C. Gibson. 1983. Biogeography. C.V. Mosby Co., St. Louis.
- Carothers, S.W., R.R. Johnson and S.W. Aitchison. 1974. Population structure and social organization of southwestern riparian birds. Amer. Zool. 14: 97-108.
- Ceballos-G, G. and D. Navarro. 1985. Vertebrados Mexicanos Extintos y en Peligro de Extincion. (to be published).
- Contreras-Balderas, S. 1978. Speciation aspects and man-made community composition changes in Chihuahuan Desert fishes p. 405-431. In Symposium on the Biological Resources of the Chihuahuan Desert Region. R.H. Waver and D.H. Riskind (Eds). US National Park Service.
- Diamond, J.M. 1984. Historic Extinctions: a rose-tta stone for understanding prehistoric extinctions. p. 824-862. In Quaternary Extinctions. P.S. Martin and R. G. Klein (Eds). University of Arizona Press, Tucson.
- Gallo, J.P. 1982. Notas sobre la distribucion del manati (*Trichechus manatus*) en las costas de

- Quintana Roo. An. Inst. Biol. Univ. Nal. Auton. de Mex. 53, Ser. Zool (1): 443-448.
- Gomez-Pompa, A., C. Vazquez-Yanes and S. Guevara. 1972. The tropical rain forest: a non renewable resource. *Science* 177: 762-765.
- Greenway, J.C. 1958. Extinct and vanishing birds of the world. *Amer. Com. Int. Wildlife Protection* 13: 1-581.
- Hall, E.R. 1981. *The mammals of Northamerica*. (2nd Edition). Wiley-Interscience, N.Y.
- Hill, E.P. 1982. Beaver, *Castor canadensis*. p. 256-281. *In Wild mammals of Northamerica*. J.A. Chapman and G.A. Feldhamer (Eds). The John Hopkins University Press, Baltimore.
- Johnson, R.R., L.T. Haight and J.M. Simpson. 1977. Endangered species vs. endangered habitats: a concept. p 68-79. *In Importance, Preservation and Management of Riparian Habitats: A Symposium* (Tucson, Arizona, July 9, 1977). USDA Forest Service General Technical Report RM-43. Rocky Mountain Forest and Range Station, Fort Collins, Colo.
- King, W.B. 1981. Endangered birds of the world. ICBP Bird Red Data Book. Smithsonian Institution Press, Washington.
- Leopold, A.S. 1965. *Fauna Silvestre de Mexico*. Instituto Mexicano de Recursos Naturales Renovables, Mexico.
- Miller, R.R. 1961. Man and the changing fish fauna of the American southwest. *Pap. Michigan Acad. Sci., Arts, and Letters* 46: 365-404.
- Myers, N. 1984. Genetic resources in jeopardy. *Ambio* 13: 171-174.
- Rea, A. 1983. *Once a river*. The University of Arizona Press, Tucson.
- Rzedowski, J. 1978. *La Vegetacion de Mexico*. Limusa, Mexico.
- Simon, N. and P. Geroudent. 1970. Last survivors: the natural history of animals in danger of extinction.
- Smith, H.M. and R.B. Smith. 1979. *Synopsis of the herpetofauna of Mexico*. VI. Guide to the Mexican turtles. John Johnson, Vermont.



# The Linear Interval Method for Determining Habitat Selection of Riparian Wildlife Species<sup>1</sup>

Kerry M. Christensen<sup>2</sup>

---

Since this technique (originally developed for river otters) can be used in highly heterogeneous habitats, incorporates both categorical and continuous data, yields a physiognomic representation of habitat structure, and facilitates the use of multivariate statistics in data analysis, it is inherently superior to those techniques typically employed by wildlife ecologists in studies of habitat selection.

---

## INTRODUCTION

Many of the recent studies of habitat selection have used either the random point method (Andrew and Mosher 1982, Irwin and Peek 1983, Pierce and Peek 1984, Servheen 1983, Tilton and Willard 1982, Witmer and deCalesta 1983) as described by Marcum and Loftsgaarden (1980) or some type of mapping method (Collins et al. 1978, Johnson and Montalbano 1984, Kaminski and Prince 1984, Lokemoen et al. 1984, Maxon 1978, Pietz and Tester 1983) as described by Neu et al. (1974) to determine relative availabilities of habitat categories. Those studies employing the mapping method frequently use a planimeter to determine the area of well defined habitat types delineated on a map or aerial photograph. The relative area of each habitat type yields a measure of relative availability. Using the random point method, a random distribution of points overlaying a map (or aerial photo) of the study area determines habitat sampling locations. Habitat variables are then simultaneously categorized or measured at each location, and the relative frequency of each category represents the relative availability. Both of these techniques typically employ chi-square analysis to test the null hypothesis that habitat components are used in direct proportion to their availability.

Here I describe the "linear interval" method of determining habitat availabilities in riparian environments. In addition to determining availabilities, this method yields a physiognomic representation of habitat structure, corresponding with topographic map locations, for the riparian area under consideration. This representation facilitates the use of multivariate statistics to determine habitat selection of riparian wildlife species as described below. The applicability of

multivariate statistical methods in studying wildlife habitat is well documented (Shugart 1981, Williams 1983), and these techniques are currently being used extensively (Brown and Batzli 1984, Mannan and Meslow 1984, Munro and Rounds 1985, Pierce and Peek 1984, Rice et al. 1983, Ryan et al. 1984, Van Horne 1982).

## PROCEDURE

Using the linear interval method of riparian habitat characterization, important habitat variables are measured or categorized at some regular interval along an imaginary line parallel to the water's edge for the entire length of riparian area under consideration. In macroscale investigations, or studies involving wide-ranging species over great distances, an alternative to examining the entire length of stream is to sample only portions of the riparian area (see Rice et al. 1983). Interval distance is dictated by habitat heterogeneity and by the degree of resolution desired by the investigator. In a study of river otters (*Lutra canadensis*), I used an interval distance of 12 m. in an effort to examine microhabitat influences on otter habitat use. The habitat on each bank can be characterized either simultaneously or independently, depending mainly on the width of the stream in question, and the habitat variables being examined. In my study, examining each bank independently, I chose to measure water depth, bank slope, and percent canopy cover, and I categorized the river type (four categories), bank type (five categories), and bank vegetation type (four categories) at each location. By plotting these interval locations on a topographic map (scale 1:24,000 or larger) a complete picture of habitat structure was obtained (fig.1).

To determine habitat preferences of riparian wildlife species, observed locations of individuals are first plotted on a topographic map (fig.2), and the habitat is characterized as the interval locations were. Then using discriminant analysis (Klecka 1975), these location characteristics are compared to the interval location characteristics (availability) to determine habitat differences between used locations and the locations available. Similarly, entire areas of apparent heavy usage (concentrations

---

Paper presented at the First North American Riparian Ecosystems Conference, University of Arizona, Tuscon, Arizona April 16-18, 1985.

Kerry M. Christensen, Department of Biological Sciences, Northern Arizona University, Flagstaff, Arizona 86011.

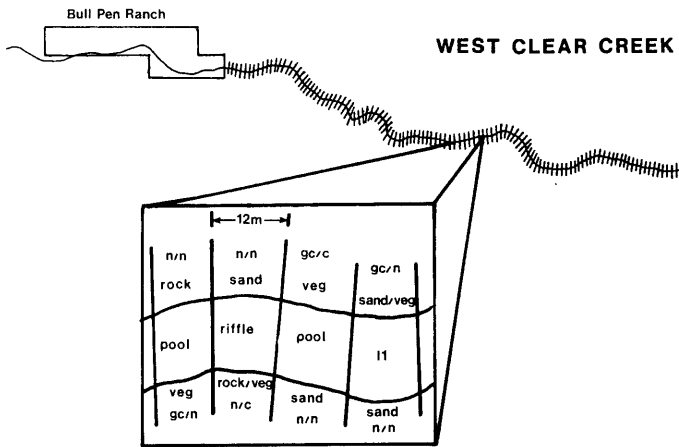

Figure 1. Sample physiognomic representation of riparian habitat using the linear interval method.

of species observations; fig.3) can be compared to unused areas, again using discriminant analysis, to determine habitat differences between used and unused areas. The habitat selection of one or several species can be determined using this methodology. The effect of season can also be examined.

Although no hard and fast rules exist for determining the sample size (number of intervals, and number of species observations) necessary for the statistical analysis, sample characteristics are very important to the validity and interpretation of the results (see Morrison 1984, and Williams 1983). Ideally, the number of interval locations used in the analysis should approximate the number of observations of the species in question, and both should be as large as possible (greater than 50 at least). Therefore when dealing with species that are sparsely distributed, and/or wide-ranging (i.e. where few observations are possible), a

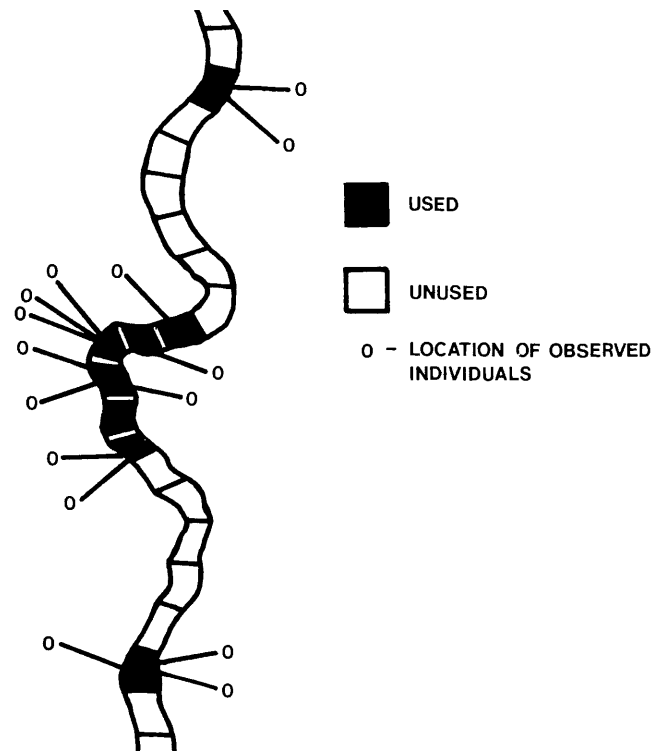

Figure 3. Hypothetical designation of used and unused areas for comparison using discriminant analysis.

number of interval locations equal to the number of observations can be randomly chosen from the entire set of interval locations, or chosen randomly from unused areas when comparing used to unused stretches. In general, Capen (1981), Green (1974,1979), Morrison (1984), Rice et al. (1983), and Williams (1983) can be consulted for discussions of the assumptions and interpretation of discriminant analysis prior to collection of data.

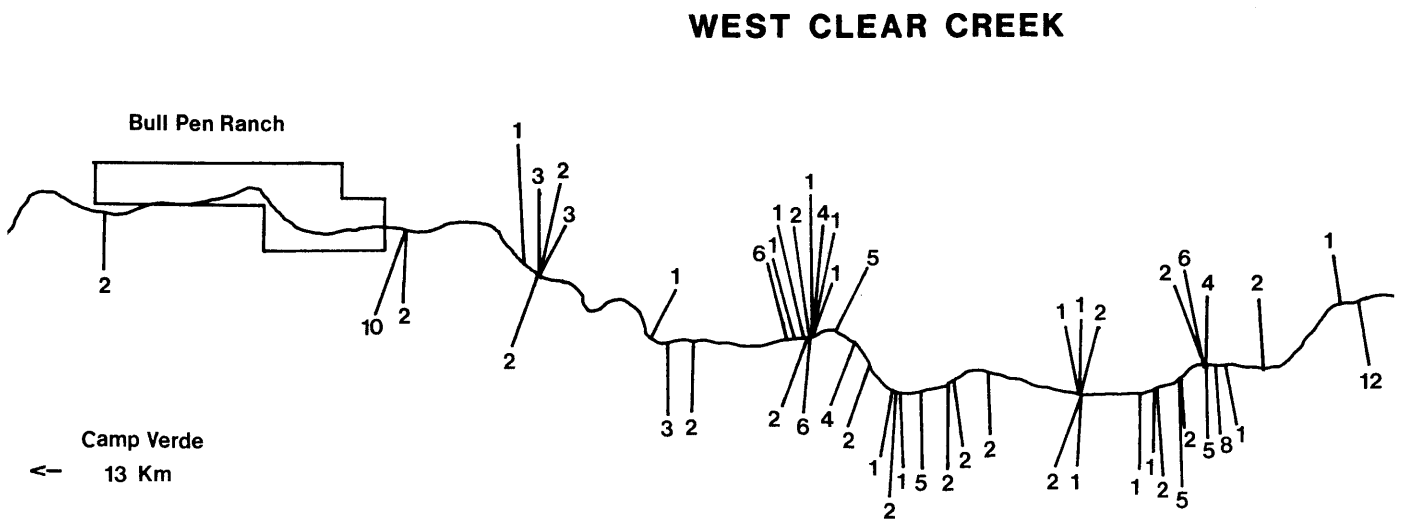

Figure 2. Locations of observed individuals plotted on a topographic map.

Results obtained from the discriminant analysis can be represented in a number of ways. I chose to create histograms of the correlation (tabulated in the analysis) between the canonical variates and the original variables (fig.4). The use of these correlations is supported by Williams (1981) and Morrison (1984). I ordered these from the largest positive correlation to the largest negative one, yielding an easily interpretable figure. Additionally, I labeled the habitat categories as to their inclusion in the step-wise procedure.

An example of the form of data entry used for the analysis is given in Table 1. Categorical variables are given a one(1) if present at the location, or a zero(0) if absent. Under the category "group", a one(1) indicates a used location, and a two(2) indicates an unused location in this example.

### DISCUSSION

The mapping method of quantifying habitat availability for determining the habitat selection of wildlife species is most useful in areas of gentle topography where habitat components form discrete entities. This usually applies to areas

Table 1. Sample data entry format used with the linear interval method and discriminant analysis.

GROUP	RIVER TYPE				BANK TYPE			VEGETATION TYPE				MAX. WATER DEPTH (m)	BANK SLOPE (degrees)	CROWN DENSITY(%)	
	POOL	RIFF	I1	I2	ROCK	SAND	VEG	ROCK/VEG	GC/CAN	NOGC/NOCAN	NOGC/CAN				GC/NOCAN
1	0	1	0	0	1	0	0	0	0	1	0	0	3.1	37	0
1	0	0	1	0	0	0	0	1	0	0	0	1	1.0	61	7
2	1	0	0	0	0	0	1	0	1	0	0	0	2.7	14	47
2	1	0	0	0	0	0	1	0	0	0	1	0	4.2	7	72

with delineated patches of different plant community types. A main drawback of this method is that habitat variables such as water depth, temperature, bank slope etc. cannot be examined and these may be of significant importance in determining whether an area is used by an animal.

The random point method has greater applicability than the mapping method especially in areas of rugged terrain with a relatively heterogeneous interspersed of habitat components. Since classification of habitat components can occur on the ground, it is possible to examine habitat parameters like those listed above, although only categorical variables can be considered when using the statistical methods promoted by Marcum and Loftsgaarden (1980; Chi-square test of homogeneity, Mendenhall 1971). Using this method, several habitat parameters can be handled simultaneously, whereas each parameter must be treated separately using the mapping method (Marcum and Loftsgaarden 1980).

The linear interval method of habitat characterization has the same advantages as the random point method, but has inherent qualities which make it a superior technique especially in riparian environments. The random point method yields availabilities only. In addition to overall availabilities, the linear interval method gives a representation of habitat structure corresponding with topographic map locations for the entire area of study (or for samples of the area as mentioned previously). This facilitates the comparison of habitat composition at different locations within the study site. Thus it is possible to compare the habitat characteristics of used and unused locations, or denning and foraging areas for example. This is not possible using the random point or mapping methods.

These within site comparisons lend themselves readily to analysis using multivariate statistical methods. As previously mentioned, a drawback of the statistical procedure advocated by Marcum and Loftsgaarden (1980; Chi-square test of homogeneity, Mendenhall 1971) is that the habitat components examined must be categorical variables. Discriminant analysis accommodates both categorical and continuous data (table 1.).

The linear interval method of examining habitat structure can be applied to studies of any riparian wildlife species. Although this method is most applicable to riparian environments, it can also be used in other linear habitats such as forest edges, or coastal and lentic shorelines. Modifications of this procedure (such as characterization of grid points in a square design) may increase the applicability of this technique.

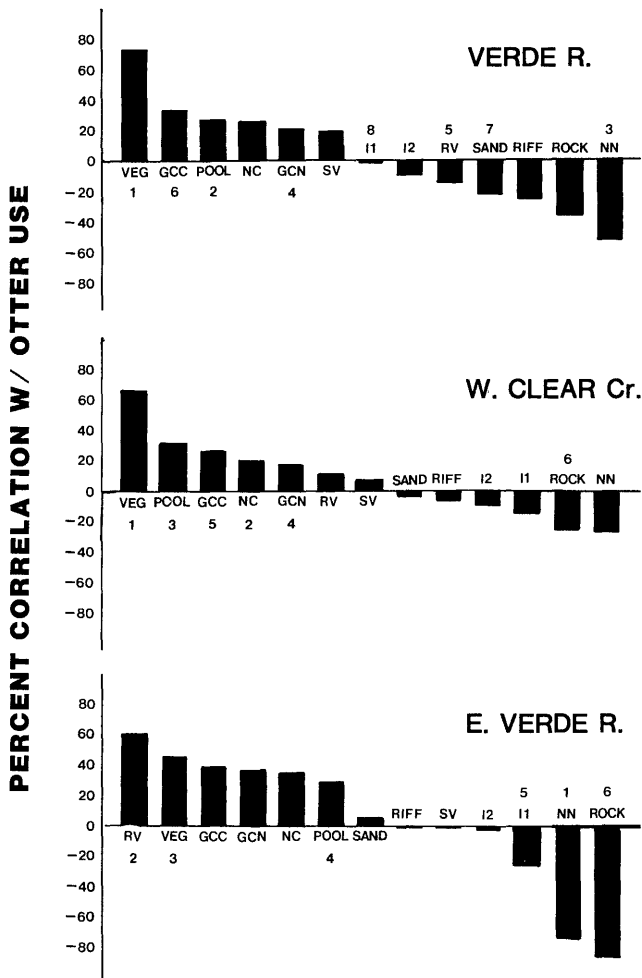

Figure 4. An easily interpretable representation of the results from the discriminant analysis using data from my otter study.

## LITERATURE CITED

- Andrew, J.M. and J.A. Mosher. 1982. Bald eagle nest site selection and nesting habitat in Maryland. *J. Wildl. Manage.* 46(2): 382-390.
- Brown, B.W. and G.O. Batzli. 1984. Habitat selection by fox and gray squirrels: a multivariate analysis. *J. Wildl. Manage.* 48(2): 616-621.
- Capen, D.E. (ed.) 1981. The use of multivariate statistics in studies of wildlife habitat. Rocky Mtn. For. and Range Expt. Stn. General Tech. Rep. RM-87.
- Collins, W.B., P.J. Urness, and D.D. Austin. 1978. Elk diets and activities in different lodge-pole pine habitat segments. *J. Wildl. Manage.* 42: 799-810.
- Green, R.H. 1974. Multivariate niche analysis with temporally varying environmental factors. *Ecology* 55: 73-83.
- \_\_\_\_\_. 1979. Sampling design and statistical methods for environmental biologists. J. Wiley and Sons, New York, New York, USA.
- Irwin, L.L. and J.M. Peek. 1983. Elk habitat use relative to forest succession in Idaho. *J. Wildl. Manage.* 47(3): 664-672.
- Johnson, F.A. and F. Montalbano III. 1984. Selection of plant communities by wintering waterfowl on Lake Okeechobee, Florida. *J. Wildl. Manage.* 48(1): 174-178.
- Kaminski, R.M. and H.H. Prince. 1984. Dabbling duck habitat associations during spring in Delta Marsh, Manitoba. *J. Wildl. Manage.* 48(1): 37-50.
- Klecka, W.R. 1975. Discriminant analysis. pp.434-467. In: Nie, N.H., C.H. Hull, J.G. Jenkins, K. Steinbrenner, and D.H. Bent (eds.). *Statistical package for the social sciences*. Second edition. 675pp. McGraw-Hill, N.Y., N.Y.
- Lokemoen, J.T., H.F. Duebbert, and D.E. Sharp. 1984. Nest spacing, habitat selection, and behavior of waterfowl on Miller Lake Island, North Dakota. *J. Wildl. Manage.* 48(2): 309-321.
- Mannan, R.W. and E.C. Meslow. 1984. Bird populations and vegetation characteristics in managed and old-growth forests in northeastern Oregon. *J. Wildl. Manage.* 48(4): 1219-1238.
- Marcum, C.L. and D.O. Loftsgaarden. 1980. A non-mapping technique for studying habitat preferences. *J. Wildl. Manage.* 44(4): 963-968.
- Maxon, S.J. 1978. Spring home range and habitat use by female ruffed grouse. *J. Wildl. Manage.* 42: 61-71.
- Mendenhall, W. 1971. Introduction of probability and statistics. Third edition. Duxbury Press, Belmont, Ca. 466pp.
- Morrison, M.L. 1984. Influence of sample size on discriminant function analysis of habitat use by birds. *J. Field Ornithol.* 55(3): 330-335.
- Munro, H.L. and R.C. Rounds. 1985. Selection of artificial nest sites by five sympatric passerines. *J. Wildl. Manage.* 49(1): 264-276.
- Neu, C.W., C.R. Byers, and J.M. Peek. 1974. A technique for analysis of utilization-availability data. *J. Wildl. Manage.* 38: 541-545.
- Pierce, D.J. and J.M. Peek. 1984. Moose habitat use and selection patterns in north-central Idaho. *J. Wildl. Manage.* 48(4): 1335-1343.
- Pietz, P.J., and J.R. Tester, 1983. Habitat selection by snowshoe hares in north-central Minnesota. *J. Wildl. Manage.* 47(3): 686-696.
- Rice, J., R.D. Ohmart, and B.W. Anderson. 1983. Habitat selection attributes of an avian community: a discriminant analysis investigation. *Ecol. Monographs* 53(3): 263-290.
- Ryan, M.R., R.B. Renken, and J.J. Dinsmore. 1984. Marbled Godwit habitat selection in the northern prairie region. *J. Wildl. Manage.* 48(4): 1206-1218.
- Servheen, C. 1983. Grizzly bear food habits, movements, and habitat selection in the Mission Mtns., Montana. *J. Wildl. Manage.* 47(4): 1026-1035.
- Shugart, H.H. 1981. An overview of multivariate methods and their application to studies of wildlife habitat. Pp. 4-10 In: D.E. Capen (ed.). *The use of multivariate statistics in studies of wildlife habitat*. Rocky Mtn. For. and Range Expt. Stn. Gen. Tech. Rep. RM-87.
- Tilton, M.E., and E.E. Willard. 1982. Winter habitat selection by mountain sheep. *J. Wildl. Manage.* 46(2): 359-366.
- Williams, B.K. 1981. Discriminant analysis in wildlife research: theory and applications. Pp. 59-71. In: D.E. Capen (ed.). *The use of multivariate statistics in studies of wildlife habitat*. Rocky Mtn. For. and Range pt. Stn. Gen Tech. Rep. RM-87.
- \_\_\_\_\_. 1983. Some observations on the use of discriminant analysis in ecology. *Ecology* 64(5): 1283-1291.
- Witmer, G.W. and D.S. deCalesta. 1983. Habitat use by female roosevelt elk in the Oregon coast range. *J. Wildl. Manage.* 47(4): 933-939.
- Van Horne, B. 1982. Niches of adult and juvenile deer mice (*Peromyscus maniculatus*) in seral stages of coniferous forest. *Ecology* 63(4): 992-1003.

# Significance of Riparian Vegetation to Breeding Birds Across an Altitudinal Cline<sup>1</sup>

Fritz L. Knopf<sup>2</sup>

---

**Abstract.**--The relative significance of riparian zones to breeding birds was documented at 6 elevations between 1,200 and 2,750 m in the Platte River drainage of the Colorado Front Range. Bird communities were inventoried during 1,440 10-min surveys at points in riparian and upland vegetation on the 6 study areas during May and June 1981-1982. Totals of 124 and 111 species were observed on the 6 study areas during the 2 years; 82% of all species were observed in riparian sites. Species richness was higher in riparian sites than in uplands. Riparian bird communities were simplistically structured at high elevations and most complex at lower elevations; upland communities were more complex at higher elevations. Higher diversity analyses indicated that riparian sites at the lowest and highest elevations are most significant to a regional avifauna. Management actions to enhance avian communities in western states should place primary emphasis on riparian zones at low elevations, secondary emphasis on those at the highest elevations, and de-emphasize efforts at intermediate elevations.

---

## INTRODUCTION

Riparian communities are the relatively mesic vegetative associations occurring along streams, rivers, and moist sites of the western United States. These systems generally: include well-defined vegetative zones within much drier surrounding areas, constitute a minor proportion of the overall area, produce more biomass, and are a critical source of diversity within the ecosystem (Thomas et al. 1979). This latter, seemingly inherent, characteristic of increased biotic diversity has fostered the tendency to define significance of riparian tracts to wildlife in terms of species diversity measures.

The significance of riparian sites to breeding birds has been defined primarily at the alpha diversity level (see Whittaker [1975] for a review of levels of diversity). In a recent analysis, Samson and Knopf (1982) concluded that alpha diversity provides a localized assessment

of the significance of a vegetative association to an avifauna, and that between-habitat (beta) and regional (gamma) diversity evaluations are more meaningful. Riparian communities, especially, cannot be addressed as functional entities but must be evaluated and managed relative to patterns within entire watersheds (Odum 1979). To date, studies of the significance of riparian vegetation have been conducted primarily at lower elevation sites where cottonwood (*Populus* spp.) and willow (*Salix* spp.) compose most of the woody vegetative structure available to birds (Carothers et al. 1974). Because avian species richness generally declines with increasing elevation (Terborgh 1971, Diamond 1973), riparian zones at higher elevations--where the diversity of upland vegetative structure is greater--may be less unique or important. This study describes the significance of riparian tracts to breeding birds within the Platte River watershed in the east-central Rocky Mountain region.

## STUDY AREAS

The study was conducted at 6 areas within the Platte River drainage of northern Colorado. Areas represented the major life zones (excluding alpine) of vegetation along the Front Range. One riparian and 1 upland site were

---

<sup>1</sup>Paper presented at the North American Riparian Conference, Tucson, Arizona, 16-18 April 1985.

<sup>2</sup>Fritz L. Knopf is Project Leader for Avian Studies, Ecology Branch, Denver Wildlife Research Center, Fort Collins, Colo.

selected within each area. Riparian sites contained a permanent stream. Cattle had not grazed on sites for at least 3 years prior to the study. The sites and vegetative communities (after Harrington 1954) included:

1. Sand sagebrush mixed-prairie type (SSMP): South Platte River, 2 km S Crook, Logan County (elevation 1,200 m). Sand sagebrush (Artemisia filifolia) is the only woody species occurring on sandhills in the mixed prairie type. The riparian site averages about 1 km wide and is dominated by plains cottonwood (P. sargentii), western snowberry (Symphoricarpos occidentalis), coyote willow (S. exigua), peach-leaf willow (S. amygdaloides), and common poison-ivy (Toxicodendron radicans).
2. Mountain shrub transition type (MST): Lone Pine Creek, 11 km W Livermore, Larimer County (elevation 1,909 m). True mountainmahogany (Cercocarpus montanus), antelope bitterbrush (Purshia tridentata), and gooseberry (Ribes spp.) dominate the upslope, which also includes scattered Rocky Mountain junipers (Juniperus scopulorum). The riparian site ranges up to 10 m wide and is dominated by plains cottonwood, scattered bush willows, and common chokecherry (Prunus virginiana).
3. Pine type (P): Meadow Creek, 16 km NW, and Sheep Creek, 29 km NW, Livermore; and Stub Creek, 4 km ESE Glendevy, Larimer County (mean elevation 2,293 m). Ponderosa pine (Pinus ponderosa) forests cover uplands at Meadow and Sheep creeks; open stands contain scattered big sagebrush (A. tridentata). The upland at Stub Creek is lodgepole pine (P. contorta) forest. Riparian sites range from 2-15 m wide and are dominated by plains cottonwood and alder (Alnus spp.) at Meadow Creek, shrub willow at Stub Creek, and mixed plains cottonwood, narrowleaf cottonwood (P. angustifolia) and willow with occasional aspen (P. tremuloides) and Englemann spruce (Picea engelmannii) at Sheep Creek.
4. Semi-desert shrub type (SDS): Illinois River, 10 km S Walden, Jackson County (elevation 2,500 m). Upland vegetation is big sagebrush. The riparian site ranges up to 100 m wide and is exclusively shrub willows (see Cannon and Knopf 1984).
5. Aspen type (A): Laramie River, 6.5 km N Chambers Lake, Larimer County (elevation 2,631 m). Upland communities are dominated by aspen with occasional Douglas-fir (Pseudotsuga menziesii) and lodgepole pine. The riparian community ranges from 20-40 m wide and is composed of shrub willows.

6. Spruce-fir forest type (SFF): South Fork of the Cache la Poudre River, Colorado State University Pingree Park Campus, Larimer County (elevation 2,747 m). Upland vegetation includes lodgepole pine, limber pine (P. flexilis), Englemann spruce, Douglas-fir, and subalpine fir (Abies lasiocarpa) with scattered, stunted aspen occasionally occurring as undergrowth. The riparian site is a glacial moraine, ranges up to 100 m wide, and is exclusively bush willow.

#### METHODS

Avian communities in riparian and upland vegetation were surveyed at each area using point-transect techniques (Reynolds et al. 1980) during May and June 1981-1982. Sixty survey stations were located in each vegetative type (120/area). Stations were at paced 100-m intervals. Within riparian sites, stations were located along, and at random distances perpendicular to, the streambank. Some stations were located on the streambank in extremely narrow riparian sites, or at greater intervals to avoid visual overlap between stations. Stations within uplands were located along a single transect oriented perpendicular to the riparian zone. The upland transect began at least 100 m from the riparian zone and at least 50 m into the upland vegetation.

Avian surveys were conducted from a half hour before sunrise until 1000 hours, except during periods of inclement weather. Riparian and upland surveys were conducted simultaneously during a 4-day period during late May (lowest elevation) and early-to-mid-June (higher elevations) at each study area. An observer waited at a station for 1 min prior to commencing bird observations, then recorded all individuals seen within a 10-min period. Thus, a motionless observer surveyed each site for 10 hours within a 4-day period. Birds not seen (but heard) were ignored to avoid potential biases due to variability in vocalization rates among species and in observer ability to identify songs and calls.

#### RESULTS

Totals of 124 and 111 species were observed at the 6 study areas in 1981 and 1982, respectively. In 1981, 57 species (46%) were observed only in riparian sites, 22 (18%) only in upland sites, and 45 (36%) in both. Thus, 82% of the species observed were in riparian vegetation, and 54% in uplands. The data for 1982 were similar with 42 (38%), 20 (18%), and 49 (44%) species observed in only riparian, only upland, or both sites, respectively. Again, 82% of all species were observed in riparian vegetation; a higher proportion (62%) occurred in uplands than in 1981. The 3 most abundant species at each site are listed in table 1.

Table 1.--Three most common bird species (in order of abundance) seen in riparian or upland vegetation at 6 study areas in northern Colorado, 1981. Percentages of sightings that were of these species is in parentheses. Dominance patterns were similar in 1982. Species codes follow Klimkiewicz and Robbins (1978).

Study area	Riparian	Upland
SSMP (1,200 m)	HOWR NOOR (44) AMRO	GRSP WEME (80) MODO
MST (1,909 m)	YEWA LABU (30) HOWR	RSTO VESP (61) GTTO
P (2,293 m)	AMRO BTHU (38) MGWA	YRWA AMRO (38) GTTO
SDS (2,500 m)	YEWA BHCO (42) SASP	BRSP GTTO (72) HOLA
A (2,631 m)	WIWA AMRO (41) YEWA	YRWA WAVI (63) BTHU
SFF (2,747 m)	WIWA LISP (52) AMRO	EVGR YRWA (31) RCKI

#### Within-Habitat Comparisons

The greatest number of species unique to a site tended to be in the lowest riparian site (table 2). In 1981, species richness in riparian habitats declined with increasing altitude, with 42 species at the SSMP site vs. 21 at the subalpine site. In 1982, however, richness was comparable (40, 41, 42, respectively) in the 3 lower riparian sites. The only species richness pattern observed in upland sites was that comparatively few species were present at the lowest elevation (SSMP). Species richness of communities in both the riparian and upland vegetation changed most dramatically between years at intermediate elevations (P and SDS sites), probably indicating altitudinal shifts relative to seasonal weather patterns at those elevations.

Within habitat types, a percentage similarity (Whittaker 1975:118) matrix among sites and for both years combined indicated a mean ( $\pm$  SE) similarity of  $0.265 \pm 0.027$  among riparian communities as opposed to  $0.130 \pm 0.032$  among upland communities ( $t=3.51$ ;  $df=83$ ;  $P<0.01$ ). Thus, bird communities in riparian sites were twice as similar as those in upland sites; upland sites had greater beta diversity across the cline.

#### Between-Habitat Comparisons

Species richness was higher in riparian than adjacent upland sites (table 2), except in SSF uplands in 1981 and P uplands in 1982. More species were common to riparian and upland sites at intermediate elevations. The number of species unique to riparian sites were generally lowest at coniferous (P and SFF) sites. Also, species richness within uplands tended to be highest at coniferous sites.

I plotted dominance-diversity curves (Patil and Taillie 1979) of the bird communities across the elevational cline for 1981. These curves can be interpreted similarly to the species-importance curves of Whittaker (1975). Curves for upland sites were simplistic (being of straight line or geometric form) at lower elevations and showed a tendency toward increasing numbers of species of intermediate or low abundance as elevation increased (fig. 1). Alternatively, curves for riparian sites indicated many species of intermediate and rare abundance at lower elevations. Separation of riparian and upland curves lended further evidence to the greater importance of riparian zones at lower (<1,909 m) sites. Importance of riparian zones decreased above 1,909 m. The highest area (SSF) had a more diverse avifauna on the upland site than on the riparian site.

Table 2.--Avian species richness within riparian and upland vegetation at 6 study areas in northern Colorado, 1981/1982.

Study area	No. of Species			
	Riparian only	Upland only	Both sites	Area total
SSMP (1,200 m)	38/35	5/4	4/5	47/44
MST (1,909 m)	31/33	8/8	9/8	48/49
P (2,293 m)	15/14	10/16	12/28	37/58
SDS (2,500 m)	22/21	9/4	13/6	44/31
A (2,631 m)	25/15	9/12	6/6	43/37
SFF (2,747 m)	15/15	19/12	6/6	40/33

Locally, riparian sites provided habitats for a more diverse avifauna than adjacent uplands (table 3). Only at the highest elevation in 1981 was alpha diversity greater in an upland site. Diversity values were highly comparable between years within riparian and upland sites at lower elevations, suggesting greater stability at those elevations. Calculations of species turnover supported greater stability in the low riparian habitats, but not for uplands. Species turnover between years was greatest in both vegetation types at intermediate elevations.

Table 3.--Shannon-Wiener Function ( $H'$ ) calculations (Pielou 1975:8) and species turnover (*op. cit.*, 99; in parentheses) for avian communities of riparian and upland sites in northern Colorado, 1981-1982.

Study area	Riparian	Upland
SSMP (1,200 m)	4.24/4.29 (0.27)	2.26/2.25 (0.34)
MST (1,909 m)	4.57/4.62 (0.27)	3.20/3.19 (0.29)
P (2,293 m)	4.05/4.61 (0.38)	3.99/4.59 (0.39)
SDS (2,500 m)	4.18/3.54 (0.40)	2.69/2.24 (0.44)
A (2,631 m)	4.20/4.02 (0.41)	3.23/3.95 (0.23)
SFF (2,747 m)	3.57/3.10 (0.34)	4.21/2.85 (0.35)

Community coefficients (table 4) indicated that (relative to numbers of species present) riparian and upland avian communities were most unique (i.e., low values) at the lowest elevation and most similar (higher values) at intermediate elevations. Similarity indices (that include species abundance information) reflected this pattern, although the avian communities at the highest elevation were as dissimilar as those at the lowest elevation. Riparian and upland communities were most similar at sites of P uplands.

Table 4.--Beta diversity comparisons of riparian and upland avian communities at 6 study areas in northern Colorado (1981/1982).

Study area	Community coefficient	Similarity index
SSMP (1,200 m)	0.157/0.204	0.082/0.146
MST (1,909 m)	0.316/0.281	0.217/0.165
P (2,293 m)	0.490/0.651	0.403/0.530
SDS (2,500 m)	0.429/0.324	0.100/0.410
A (2,631 m)	0.346/0.630	0.203/0.392
SFF (2,747 m)	0.261/0.308	0.164/0.060

#### DISCUSSION

Studies of avifaunal associations of riparian zones in the West have established the importance of these vegetative associations to

wildlife (Hubbard 1971, Johnson et al. 1977, Stevens et al. 1977). The major emphasis of my study was to describe the pattern of importance within riparian zones across an altitudinal gradient, especially as that pattern relates to prioritization of agency management programs.

To date, floodplain zones at lower elevations have received the most emphasis in western riparian management. Concerted efforts have been initiated to re-establish cottonwood stands in California (Anderson et al. 1984) and Colorado. This study confirms the greater uniqueness of those low-elevation sites both locally and within a continuous drainage. Uniqueness appears independent of the width of the riparian zone when identified by similar species richness and alpha diversities at the extremely narrow zone of the 1,909-m site vs. the broad floodplain at 1,200 m.

Studies of avian communities across elevational gradients in eastern North America (Able and Noon 1976, Sabo 1980) have indicated that communities become simpler and uneven at higher elevations, with decreases in rare species and increasing dominance by a few species. These trends usually are attributed to more severe environmental conditions at higher elevations. My surveys at 6 study areas in Colorado failed to support these patterns in either riparian or upland communities. Where patterns were observed, they generally were inconsistent between years. Although I cannot conclude that climatic associates of elevation influenced avian community structure, annual variation in weather certainly resulted in comparable turnover rates in riparian and upland sites at most elevations.

The uniqueness of a riparian zone at a location was influenced by upland vegetation. Riparian zones tended to support a more diverse avifauna than upland habitats except in areas of coniferous forests. The 2 habitat types shared more species in uplands of P, A, and SDS than in SFF or lowland shrub-grasslands (SSMP and MST).

Studies of avian communities, including those in riparian zones (e.g., Bull and Skovlin 1982), often attribute greater species richness or diversity to greater structural diversity of the vegetative community and, thus, to the availability of more niches. The generality of the relationship has been dismissed (Willson 1974, Balda 1975), but persists in the literature. Bird species richness in aspen forest was lower than the adjacent riparian shrub-willow community that had avifaunal diversity comparable to a pine forest. Avian community diversity was not related to vegetational structure in northern Colorado.

Beedy (1981) surveyed birds in closed-canopy and open-forest coniferous communities and found greater diversity in the open forests, presumably due to greater structural complexity (i.e., developed shrub community and open spaces



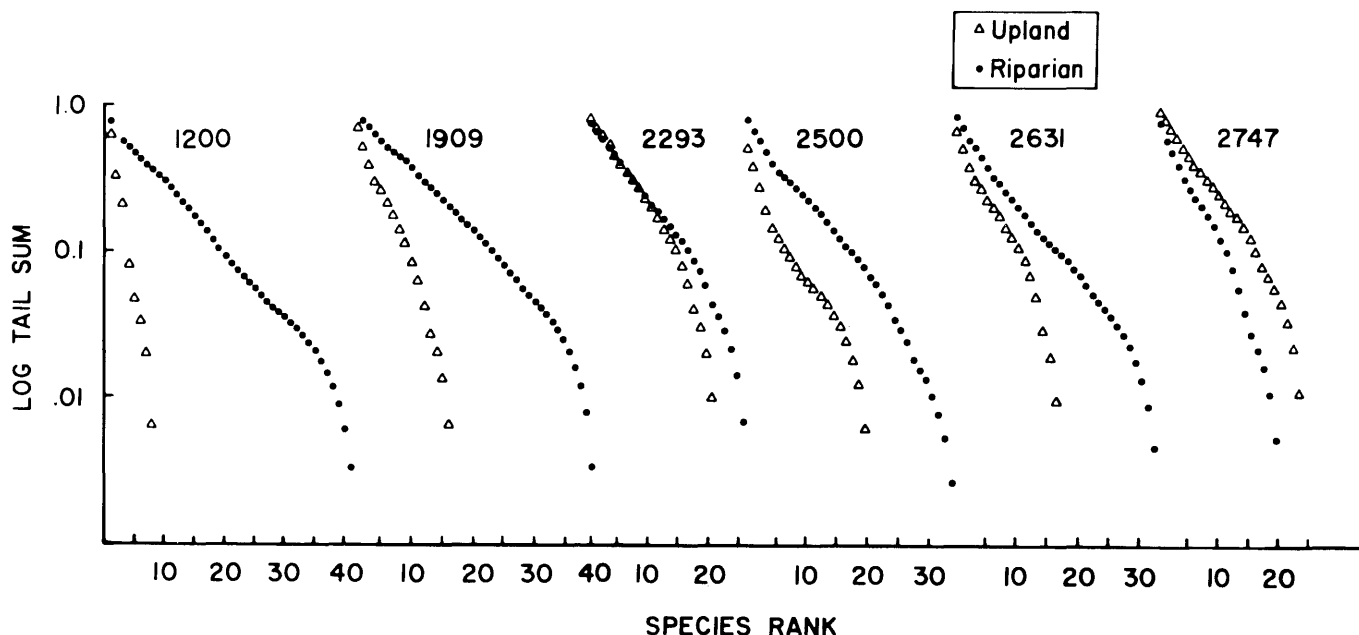

Figure 1.--Dominance-diversity curves for riparian and upland bird communities at 6 elevations in northern Colorado, 1981.

in the canopy for flycatching species). Horizontal patchiness (Roth 1976) likely accounted for the highest avian diversity being observed in the eastern Colorado SSMP site. That community is an old-growth cottonwood (Sedgwick and Knopf, in prep.) savannah with an extensive woody understory. Such open-canopy, low sites are the major sources of avian diversity regionally.

#### CONCLUSIONS

Based upon these findings, I conclude that:

1. More species of birds occur in riparian vegetation than in adjacent uplands along the Colorado Front Range.
2. Locally, the most diverse avifauna occurs in riparian zones at lower elevations (<2,000 m). Riparian communities also tend to be more stable between years, with lower species turnover.
3. Regionally, the most diverse avifauna occurs in upland vegetation, and upland bird communities strongly influence bird species composition in riparian zones across an elevational cline.
4. Faunal interchange across an elevational gradient is greater among riparian sites than among upland sites.
5. Due to the faunal mixing patterns, bird communities in riparian zones tend to be most unique within a region at the ends of an elevational continuum: in

floodplains at low elevations and spruce-fir uplands at high elevations.

#### ACKNOWLEDGMENTS

This research benefited from the ideas of R. W. Cannon and C. P. Stone. R. Desilet assisted in locating field sites. Field or analytical assistance was provided by R. W. Cannon, J. F. Ellis, T. E. Olson, E. A. Remington, E. L. Smith, and J. P. Ward. E. C. Patten and W. J. Wilson of Arapaho National Wildlife Refuge and M. Gardner of the South Platte Wildlife Management Area permitted us to work at those sites. The Forest Service and Colorado State University granted permission to work within their holdings. This research is a product of Cooperative Agreement No. 2463-4 between the Colorado Division of Wildlife and Denver Wildlife Research Center, U.S. Fish and Wildlife Service. I thank W. D. Graul, J. R. Grieb, C. Jones, R. Moss, and R. K. Towry for administrative assistance. J. L. Oldemeyer and J. A. Sedgwick commented on the manuscript.

#### LITERATURE CITED

- Able, K. P., and B. R. Noon. 1976. Avian community structure along elevational gradients in the northeastern United States. *Oecologia* 26:275-294.
- Anderson, B. W., J. Disano, D. L. Brooks, and R. D. Ohmart. 1984. Mortality and growth of cottonwood on dredge-spoil. Pages 438-444 in R. E. Warner and K. M. Hendrix, Eds. *California Riparian Systems*. California Press, Berkeley. 1035 p.

- Balda, R. P. 1975. Vegetation structure and breeding bird diversity. Pages 59-80 in D. R. Smith, Tech. Coord. Symposium on management of forest and range habitats for nongame birds. USDA Forest Service General Technical Report WO-1. Washington, D.C. 343 p.
- Beedy, E. C. 1981. Bird communities and forest structure in the Sierra Nevada of California. *Condor* 83:97-105.
- Bull, E. L., and J. M. Skovlin. 1982. Relationships between avifauna and streamside vegetation. *Transactions North American Wildlife and Natural Resources Conference* 47:496-506.
- Cannon, R. W., and F. L. Knopf. 1984. Species composition of a willow community relative to seasonal grazing histories in Colorado. *Southwestern Naturalist* 29:234-237.
- Carothers, W. W., R. R. Johnson, and S. W. Aitchison. 1974. Population structure and social organization of southwestern riparian birds. *American Zoologist* 14:97-108.
- Diamond, J. M. 1973. Distributional ecology of New Guinea birds. *Science* 179:759-769.
- Harrington, H. D. 1954. *Manual of the plants of Colorado*. Sage Books. Denver, Colo. 666 p.
- Hubbard, J. P. 1971. The summer birds of the Gila Valley, New Mexico. *Nemouria* No. 2. 35 p.
- Johnson, R. R., L. T. Haight, and J. M. Simpson. 1977. Endangered species vs. endangered habitats: a concept. Pages 68-79 in R. R. Johnson and D. A. Jones, Eds. *Importance, preservation and management of riparian habitat: a symposium*. USDA Forest Service General Technical Report RM-43. 217 p.
- Klimkiewicz, M. K., and C. S. Robbins. 1978. Standard abbreviations for common names of birds. *North American Bird Bander* 3:16-25.
- Odum, E. P. 1979. Ecological importance of the riparian zone. Pages 2-4 in R. R. Johnson and J. F. McCormick, Eds. *Strategies for protection and management of floodplain wetlands and other riparian ecosystems*. USDA Forest Service General Technical Report WO-12. 410 p.
- Patil, G. P., and C. Taillie. 1979. A study of diversity profiles and orderings for a bird community in the vicinity of Colstrip, Montana. Pages 23-38 in G. P. Patil and M. Rosenzweig, Eds. *Contemporary quantitative ecology and related ecometrics*. International Cooperative Publication House, Fairland, Mass. 695 p.
- Pielou, E. C. 1975. *Ecological diversity*. John Wiley & Sons, Inc., New York, N.Y. 165 pp.
- Reynolds, R. T., J. M. Scott, and R. A. Nussbaum. 1980. A variable circular-plot method for estimating bird numbers. *Condor* 82:309-313.
- Roth, R. R. 1976. Spatial heterogeneity and bird species diversity. *Ecology* 57:773-782.
- Sabo, S. R. 1980. Niche and habitat relations in subalpine bird communities of the White Mountains of New Hampshire. *Ecological Monographs* 50:241-259.
- Samson, F. B., and F. L. Knopf. 1982. In search of a diversity ethic for wildlife management. *Transactions North American Wildlife and Natural Resources Conference* 47:421-431.
- Stevens, L., B. T. Brown, J. M. Simpson, and R. R. Johnson. 1977. The importance of riparian habitat to migrating birds. Pages 156-164 in R. R. Johnson and D. A. Jones, Jr., Eds. *Importance, preservation and management of riparian habitat: a symposium*. USDA Forest Service General Technical Report RM-43. 217 p.
- Terborgh, J. 1971. Distribution on environmental gradients: theory and a preliminary interpretation of distributional patterns in the avifauna of the Cordillera Vilcabamba, Peru. *Ecology* 51:23-40.
- Thomas, J. W., C. Maser, and J. E. Rodiek. 1979. Wildlife habitats in managed rangelands--the Great Basin of Southeastern Oregon. Riparian zones. USDA Forest Service General Technical Report PNW-80. 18 p.
- Whittaker, R. H. 1975. *Communities and ecosystems*. MacMillan Co., New York, N.Y. 385 p.
- Willson, M. F. 1974. Avian community organization and habitat structure. *Ecology* 55:1017-1029.

## APPENDIX

Species of birds observed during 1,440 10-min stationary census at 6 study areas in northern Colorado, 1981-1982.

Great Blue Heron <u>Ardea herodias</u>	Western Flycatcher <u>Empidonax difficilis</u>	Red-eyed Vireo <u>Vireo olivaceus</u>
Black-crowned Night-Heron <u>Nycticorax nycticorax</u>	Ash-throated Flycatcher <u>Myiarchus cinerascens</u>	Orange-crowned Warbler <u>Vermivora celata</u>
Wood Duck <u>Aix sponsa</u>	Great Crested Flycatcher <u>Myiarchus crinitus</u>	Nashville Warbler <u>Vermivora ruficapilla</u>
Green-winged Teal <u>Anas crecca</u>	Western Kingbird <u>Tyrannus verticalis</u>	Virginia's Warbler <u>Vermivora virginiae</u>
Mallard <u>Anas platyrhynchos</u>	Eastern Kingbird <u>Tyrannus tyrannus</u>	Yellow Warbler <u>Dendroica petechia</u>
Northern Pintail <u>Anas acuta</u>	Horned Lark <u>Eremophila alpestris</u>	Magnolia Warbler <u>Dendroica magnolia</u>
Blue-winged Teal <u>Anas discors</u>	Tree Swallow <u>Tachycineta bicolor</u>	Yellow-rumped warbler <u>Dendroica coronata</u>
Cinnamon Teal <u>Anas cyanoptera</u>	Violet-green Swallow <u>Tachycineta thalassina</u>	American Redstart <u>Setophaga ruticilla</u>
Northern Shoveler <u>Anas clypeata</u>	Northern Rough-winged Swallow <u>Stelgidopteryx serripennis</u>	Ovenbird <u>Seiurus aurocapillus</u>
Gadwall <u>Anas strepera</u>	Cliff Swallow <u>Hirundo pyrrhonota</u>	Northern Waterthrush <u>Seiurus noveboracensis</u>
Common Merganser <u>Mergus merganser</u>	Barn Swallow <u>Hirundo rustica</u>	MacGillivray's Warbler <u>Oporornis tolmiei</u>
Northern Harrier <u>Circus cyaneus</u>	Gray Jay <u>Perisoreus canadensis</u>	Common Yellowthroat <u>Geothlypis trichas</u>
Sharp-shinned Hawk <u>Accipiter striatus</u>	Steller's Jay <u>Cyanocitta stelleri</u>	Wilson's Warbler <u>Wilsonia pusilla</u>
Northern Goshawk <u>Accipiter gentilis</u>	Blue Jay <u>Cyanocitta cristata</u>	Yellow-breasted Chat <u>Icteria virens</u>
Swainson's Hawk <u>Buteo swainsoni</u>	Clark's Nutcracker <u>Nucifraga columbiana</u>	Western Tanager <u>Piranga ludoviciana</u>
Red-tailed Hawk <u>Buteo jamaicensis</u>	Black-billed Magpie <u>Pica pica</u>	Rose-breasted Grosbeak <u>Pheucticus ludovicianus</u>
American Kestrel <u>Falco sparverius</u>	American Crow <u>Corvus brachyrhynchos</u>	Black-headed Grosbeak <u>Pheucticus melanocephalus</u>
Ring-necked Pheasant <u>Phasianus colchicus</u>	Common Raven <u>Corvus corax</u>	Lazuli Bunting <u>Passerina amoena</u>
Blue Grouse <u>Dendragapus obscurus</u>	Black-capped Chickadee <u>Parus atricapillus</u>	Indigo Bunting <u>Passerina cyanea</u>
Wild Turkey <u>Meleagris gallopavo</u>	Mountain Chickadee <u>Parus gambeli</u>	Green-tailed Towhee <u>Pipilo chlorurus</u>
Killdeer <u>Charadrius vociferus</u>	Red-breasted Nuthatch <u>Sitta canadensis</u>	Rufous-sided Towhee <u>Pipilo erythrophthalmus</u>
Spotted Sandpiper <u>Actitis macularia</u>	White-breasted Nuthatch <u>Sitta carolinensis</u>	Cassin's Sparrow <u>Aimophila cassinii</u>
Long-billed Curlew <u>Numenius americanus</u>	Pygmy Nuthatch <u>Sitta pygmaea</u>	Chipping Sparrow <u>Spizella passerina</u>
Common Snipe <u>Gallinago gallinago</u>	Brown Creeper <u>Certhia americana</u>	Clay-colored Sparrow <u>Spizella pallida</u>
Forster's Tern <u>Sterna forsteri</u>	Rock Wren <u>Salpinctes obsoletus</u>	Brewer's Sparrow <u>Spizella breweri</u>
Mourning Dove <u>Zenaidura macroura</u>	House Wren <u>Troglodytes aedon</u>	Vesper Sparrow <u>Poocetes gramineus</u>
Great Horned Owl <u>Bubo virginianus</u>	American Dipper <u>Cinclus mexicanus</u>	Lark Sparrow <u>Chondestes grammacus</u>
Burrowing Owl <u>Athene cunicularia</u>	Ruby-crowned Kinglet <u>Regulus calendula</u>	Savannah Sparrow <u>Passerculus sandwichensis</u>
Common Nighthawk <u>Chordeiles minor</u>	Blue-gray Gnatcatcher <u>Polioptila caerulea</u>	Grasshopper Sparrow <u>Ammodramus savannarum</u>
White-throated Swift <u>Aeronautes saxatalis</u>	Mountain Bluebird <u>Sialia currucoides</u>	Song Sparrow <u>Melospiza melodia</u>
Broad-tailed Hummingbird <u>Selasphorus platycercus</u>	Townsend's Solitaire <u>Myadestes townsendi</u>	Lincoln's Sparrow <u>Melospiza lincolni</u>
Belted Kingfisher <u>Ceryle alcyon</u>	Veery <u>Catharus fuscescens</u>	White-crowned Sparrow <u>Zonotrichia leucophrys</u>
Lewis' Woodpecker <u>Melanerpes lewis</u>	Swainson's Thrush <u>Catharus ustulatus</u>	Dark-eyed Junco <u>Junco hyemalis</u>
Red-headed Woodpecker <u>Melanerpes erythrocephalus</u>	Hermit Thrush <u>Catharus guttatus</u>	Red-winged Blackbird <u>Agelaius phoeniceus</u>
Yellow-bellied Sapsucker <u>Sphyrapicus varius</u>	American Robin <u>Turdus migratorius</u>	Western Meadowlark <u>Sturnella neglecta</u>
Williamson's Sapsucker <u>Sphyrapicus thyroideus</u>	Gray Catbird <u>Dumetella carolinensis</u>	Yellow-headed Blackbird <u>Xanthocephalus xanthocephalus</u>
Downy Woodpecker <u>Picoides pubescens</u>	Sage Thrasher <u>Oreoscoptes montanus</u>	Brewer's Blackbird <u>Euphagus cyanocephalus</u>
Hairy Woodpecker <u>Picoides villosus</u>	Brown Thrasher <u>Toxostoma rufum</u>	Common Crackle <u>Quiscalus quiscula</u>
Northern Flicker <u>Colaptes auratus</u>	Cedar Waxwing <u>Bombcilla cedrorum</u>	Brown-headed Cowbird <u>Molothrus ater</u>
Olive-sided Flycatcher <u>Contopus borealis</u>	Loggerhead Shrike <u>Lanius ludovicianus</u>	Orchard Oriole <u>Icterus spurius</u>
Western Wood-Pewee <u>Contopus sordidulus</u>	European Starling <u>Sturnus vulgaris</u>	Northern Oriole <u>Icterus galbula</u>
Willow Flycatcher <u>Empidonax traillii</u>	Bell's Vireo <u>Vireo bellii</u>	Red Crossbill <u>Loxia curvirostra</u>
Hammond's Flycatcher <u>Empidonax hammondi</u>	Solitary Vireo <u>Vireo solitarius</u>	Pine Siskin <u>Carduelis pinus</u>
Dusky Flycatcher <u>Empidonax oberholseri</u>	Warbling Vireo <u>Vireo gilvus</u>	American Goldfinch <u>Carduelis tristis</u>
		Evening Grosbeak <u>Coccothraustes vespertinus</u>

# On the Development of Riparian Ecology<sup>1</sup>

R. Roy Johnson<sup>2</sup> and Charles H. Lowe<sup>3</sup>

---

Abstract.--The peculiarly western development of riparian ecology in North America is examined. Gradients in riparian systems are discussed with regard to transriparian and intrariparian continua, including xeroriarian communities. Consistent with the fact that riparianlands are technically wetlands, Aquatic, Riparian, and Terrestrial systems harbor peculiarly obligate species structured into distinctive biotic communities throughout all of North America.

---

## EASTERN AND WESTERN RIPARIAN ECOSYSTEMS IN NORTH AMERICA

Riparian ecology, one of the newest of scientific disciplines, originated in the southwestern United States where wetland scientists remain few. There were several reasons for the establishment of riparian ecology in the Southwest. It was a natural development initiated by naturalists attracted to the singular distinctiveness and richness of Southwest riparian woodlands and forests--woodlands and forests correctly reminiscent of the winter-deciduous hardwood forests of the eastern United States. Water is a much more pressing problem for natural communities in the West than for those in most of the eastern United States. Eastern deciduous hardwood forests are commonly supported by 35 to 50 inches of annual precipitation. Most of the West receives less than 20 inches while pan evaporation rates commonly exceed 100 inches annually. Evaporation and runoff rates are lower in the East where vegetation holds the moisture while forming a blanket over the soil, partially protecting it from wind and sun. In eastern uplands the competition is primarily for space and light above ground, while in the arid West competition is primarily below ground for water.

In the East, the natural communities of both the riparian bottomlands and surrounding uplands commonly consist largely of deciduous hardwood forests. Even though the species composition of

these riparian communities may differ greatly from upland communities, their physiognomies are not as strongly contrasting; often there is little visual contrast between the two types. But in most of the arid and semiarid West, luxuriant riparian deciduous hardwood forests and microphyll woodlands are linear landscape communities framed sharply by contrasting desertland, scrubland, woodland, and forestland of the immediately surrounding uplands. The relative inconspicuousness of eastern riparian communities contributed to the fact that significantly fewer riparian studies happened in North America before, versus after, the late 1960's.

The late establishment of riparian ecology is due partly to the complexity of riparian ecosystems. In the ecotone formed by the land-water interface, one finds a textbook example of the edge effect (Leopold 1933). This was first discussed for riparian ecosystems by Johnson (1979a) and Odum (1979). A reticulum of interlaced species interactions and ecological processes forms a continuum between the wettest deepwater habitat and the driest upland habitat. "Until recently, structure, composition, and function of the riparian zone had received little consideration in ecosystem level research, because this zone forms the interface between scientific disciplines as well as ecosystem components" (Swanson et al. 1982). In addition to the intricacies of the land-water interface, the diversity of western ecosystems is greatly increased by extreme contrasts in soil, slope, exposure, latitude and elevation--from near 200 feet below sea level in Death Valley to more than 14,000 feet on Mount Whitney.

The role these factors play in speciation on gradients in the West is discussed by Hall (1959) who notes that the southwestern United States contains more intraspecific diversity (subspecies) in mammals than any comparable continental area in the world. Within these oft-discussed environmental gradients there are two important riparian gradients --a transriparian continuum and an intrariparian continuum (see below). While the importance of ecotones and edge effect associated with riparian

---

<sup>1</sup>Paper presented at the First North American Riparian Conference, Tucson, Arizona, April 16-18, 1985.

<sup>2</sup>R. Roy Johnson is Sr. Research Scientist with the National Park Service and Adjunct Professor of Renewable Natural Resources, University of Arizona, Tucson, Ariz.

<sup>3</sup>Charles H. Lowe is Professor of Ecology and Evolutionary Biology, University of Arizona, Tucson, Ariz.

habitats is clear, the role of transriparian and intrariparian gradients in biotic diversity and speciation have not been previously addressed and are still poorly understood.

#### Little Riparian Interest-- Eastern Ecologists on Western Landscapes

It was in this complex, diverse, and unfamiliar western ecological setting that earlier eastern ecologists conducted important studies in natural community structure and distribution. Classical ecology in North America in the sense of Clements, Daubenmire, Merriam, and others, and much of modern field ecology was, until recently, treated largely under theory and bias developed in and for non-arid regions. C. Hart Merriam, the first North American biologist to generate a general classification system for natural communities in North America, traveled from Washington, D.C. to Flagstaff, Arizona where he developed the Life Zone System (Merriam 1890, 1898). Merriam and one of his assistants, Vernon Bailey, recorded detailed observations on the volcanic-cindered slopes of the San Francisco Peaks and the surrounding Kaibab Limestone surface of the Colorado Plateau where there is no permanent surface water. In the recent preparation of a book on the birds of Grand Canyon, Arizona (Brown et al., in press) a major gap was found in the records of these eastern biologists--that for the riparian habitat of the Colorado River which they had reached by descending into the Grand Canyon. The contribution of this riverine riparian habitat to avian density in this case is enormous.

In the 1960's two well-known eastern ecologists, Robert Whittaker and William Niering (1965, 1968) conducted extensive ecological investigations on the vegetation of the Santa Catalina Mountains near Tucson, Arizona. Curiously, within these otherwise excellent studies we are provided with little more information about natural riparian communities in Arizona than that provided by Merriam 80 years earlier. Whittaker and Niering differentiated eight upland vegetational community types between 3,000 and 9,500 feet elevation. Also on this Catalina gradient there is a paralleling riparian complex of distinctive riparian vegetational types that were dismissed with the single designation "Canyon Woodland." It is worth noting again that eastern ecologists who were centrally interested in wetlands and moisture gradients did not recognize, or did not at least treat as important, the most obvious moisture gradient of all--the transriparian gradient, from the aquatic habitat of the streamway across the riparian zone into the adjacent uplands. This edaphic moisture regime--the moisture gradient associated with the aquatic to upland continuum--is a major factor controlling the biological diversity and structural complexity of riparian ecosystems in the Southwest.

#### Much Riparian Interest-- Western Users on Western Landscapes

The lack of interest in or understanding of riparian ecosystems by early investigators in the Southwest was matched by an opposite zeal in the

public sector for using riparian areas for grazing, agriculture, and urban development. "Most of the surviving river-bottom habitat has been cleared, leveled, and converted to farmlands...Perhaps nowhere else in Arizona have the changes been more dramatic" (Phillips et al. 1964). "Moreover, it is as are all ecological formations and their subdivisions, locally subject to, and often dissolved by, the vicissitudes of human occupation. In Arizona, the riparian woodlands have been rapidly dwindling just as the water table has been rapidly lowering. And its trees are now the native phreatophytes of the water-users" (Lowe 1964).

Today, two decades later and fueled by the National Environmental Policy Act (NEPA) of 1969, at least five basic national programs are concerned with the land-water interface in the United States: coastal wetlands, inland wetlands, floodplains, in-stream flow, and riparian protection and management. Numerous resource management agencies have developed riparian policy and in-house programs. Other programs, e.g., floodplain management, coincidentally touch on riparian lands. One program, instream flow, continues to emphasize sportfishing while riparian areas and their nonconsumptive recreational and wildlife values are badly in need of instream flow considerations. Four of the five programs have at least one governmental agency with a legal mandate for their administration. And, although numerous state and federal agencies have explicit or de facto riparian management policies, no coordinated national program has given riparian ecosystems the same protection as the other four. Without the needed legal mandate many types of riparian communities of native plants and animals will continue to deteriorate as some of the most endangered of all North American biotas.

#### GRADIENTS--THE CONTINUUM IN THE RIPARIAN ZONE

The etymology of the word riparian has been recently discussed by Johnson (1979b) and Warner (1984) as well as its common origin with the terms "river" and "riverine" (Johnson et al. 1984a). And as the words themselves have varied, evolving through time, so have the interpretations of their meanings. Regardless of how broadly or narrowly one defines the term, riparian areas are functionally wetlands since they are supported by inflowing water, be it perennial, intermittent, or ephemeral. The ecological concept of riparian community is properly expressed by the functional difference rather than by a strictly physical or biological definition. "A riparian association of any kind is one which occurs in or adjacent to drainageways and/or their floodplains and which is further characterized by species and/or life-forms different from that of the immediately surrounding non-riparian climax" (Lowe 1964).

The transriparian continuum extends from the water in a stream or lake into the surrounding upland. In moving along this continuum one transverses, sequentially, several aquatic and terrestrial habitat types from deep water through semiaquatic, riparian, semiriparian, and finally into upland ecosystems, in that order (fig. 1). Soil moisture forms a continuum from complete saturation on the bottom of the lake or stream to little measurable moisture at the

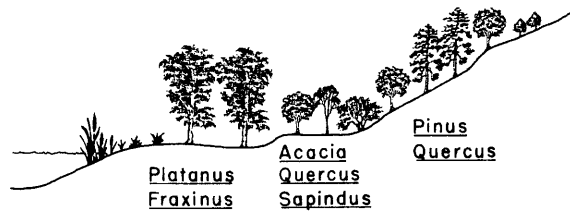

TRANSRIPIARIAN PROFILE (SOUTHERN ARIZONA)

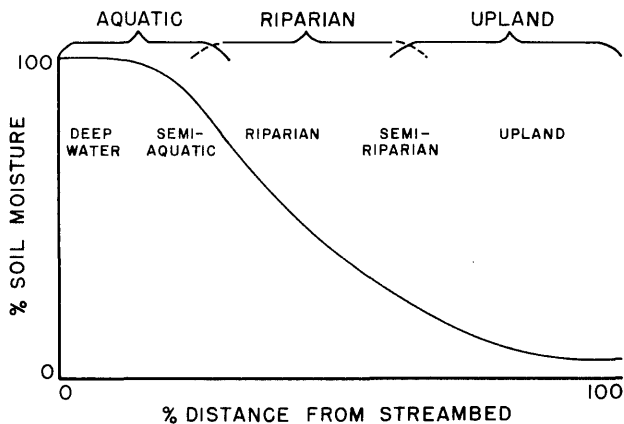

Figure 1.--Schematic of the transriparian continuum on the moisture gradient from aquatic through riparian into the adjacent upland community.

top of an adjacent rocky hill. The intrariarian continuum may be physically present in a single system, such as the Colorado River Basin. Here one can (or could before the damming of the system) travel from the hydroriarian estuarine system at the delta of the Colorado River on the Gulf of California, upstream along the hydroriarian riverine systems to its confluence with the Gila and from there to the mesoriarian habitats of the intermittent Rio San Pedro, finally terminating in the dry, desert xeroriarian habitats of the ephemeral streamcourses feeding into the San Pedro. In sharp contrast, some intrariarian systems located in the more mesic eastern U.S. and Pacific Northwest are completely hydroriarian with perennial water from the source to the mouth of the river system. Conversely, some important drainage systems, especially in Sonora and Baja California, Mexico are entirely or essentially ephemeral from their origin to the Pacific or Gulf of California.

Conceptually, the entire spectrum of the North American intrariarian continuum begins with, or varies from, something like the Florida Everglades hydroriarian system, where most species of the biotic community differ from those of the ecosystems of adjacent upland evergreen broadleaf or pine forests. From such wet extreme the continental continuum progresses uphill along a decreasing moisture gradient to the upper end of a dry riparian ecosystem along a dry desert water course; here the first order wash or arroyo may support very few species of plants and animals that are not shared

in common with biotic communities of the surrounding upland (Johnson et al. 1984b). However, even though these shared species may be preferential or facultative xeroriarian species, the washside individuals are commonly more robust and/or occur in greater densities than on the adjacent uplands. It is for this natural situation that Campbell and Green (1968) coined the term "pseudoriarian." Although no longer a useful term, as explained by Johnson et al. (1984a), it helped to draw attention to the issue during the "phreatophyte period" (1960-1975) when riparian vegetation in general was viewed as "water-wasters" by some scientists as well as by the water salvage and reclamation interests, and some resource management agencies.

#### XERORIARIAN HABITATS VERSUS UPLANDS

From a functional or biological standpoint, "wetland" is a comparative term contrasting with "dryland" or the more commonly used "upland." Most wetland ecologists, classifiers, mappers, et al. have developed their respective schemes in the more mesic East and have based them on soil moisture or water regimes (Cowardin et al. 1979, Johnson et al. 1984a). The concept of the wet riparian "big five" --cottonwood (Populus fremontii), willow (Salix species), sycamore (Platanus wrightii), ash (Fraxinus pennsylvanica velutina), and walnut (Juglans major)--finds application more or less throughout the sub-Mogollon Southwest (Lowe 1961). Minckley and Brown (1982) "updated" the list by adding alder (Alnus oblongifolia), in a wet riparian photograph of the "big six," immediately followed with another photo of the "big 6 minus one." In addition to alder one could add other species of similarly limited distribution. The "big five" are winter-deciduous hardwood trees with similarly wide ecological distributions.

Using the same criteria for xeroriarian systems in the sub-Mogollon desert region finds the dry riparian "big four"--mesquite (Prosopis species), catclaw acacia (Acacia gregii), ironwood (Olneya tesota), and blue paloverde (Cercidium floridum). It is difficult enough for an eastern biologist to understand how these four subtropical legumes can be called the dry riparian "big four." Then, when it is explained that sahuaros in extreme southwestern Arizona (annual precipitation approximately 3 inches, pan evaporation 100 inches) become ultimately riparian plants, it tends to stretch the credulity of even the most learned wetland biologist (see Lowe 1964).

Upon investigating the complex ecological processes associated with the sahuaro in regions where it is an obligate xeroriarian plant, one finds that it is, indeed, functionally a riparian species of utmost ecological importance. It is often the only large tree along these desert washes where the dry riparian "big four" are often shrubform or small trees. Numerous bird species of the region are largely or entirely dependent on the sahuaro for nesting. Red-tailed Hawks (Buteo jamaicensis), Great Horned Owls (Bubo virginianus), and Roadrunners (Geococcyx californianus) nest in sahuaro crotches while the Gila Woodpecker (Melanerpes uropygialis) and gilded race of the Common Flicker (Colaptes auratus

mearnsi) excavate cavities for nesting. The abandoned nest cavities made by these two species in turn are used by several secondary cavity nesters including the American Kestrel (Falco sparverius), Western Screech Owl (Otus kennicottii), Elf Owl (Micrathene whitneyi), extremely rare Ferruginous Pygmy-Owl (Glaucidium brasilianum), Purple Martin (Progne subis), Brown-crested Flycatcher (Myiarchus tyrannulus), Ash-throated Flycatcher (M. cinerascens), and occasionally other species, such as Lucy's Warbler (Vermivora luciae). In wet riparian habitats these birds use cottonwoods and other large riparian trees, but in these extremely arid xeroriparian situations the sahuaro is the only plant large enough to provide nest sites for all of these species.

Available moisture for a plant or animal on a yearly or seasonal basis is several times as great in the Everglades as in a desert arroyo. However, the small percentage of shared floral and faunal species between these xeroriparian sahuaro communities with adjacent desertscrub upland communities may provide as much or more biological contrast as that found when comparing shared species between an Everglades river and a pine upland.

#### SUMMARY

The mid-century development of North American riparian ecology happened where riparian ecosystems are most strikingly apparent in the landscape climax pattern--in the North American Southwest. In the West, riparian systems are wetland systems exhibiting diverse continua from wet to dry and are consequently of great interest to western field investigators in diverse pursuits. In discussing this peculiarly western development in North American field ecology, we examine some ecological concepts as they pertain to riparian ecosystems. In contrast to the situation in western North America, many riparian communities in the eastern United States are relatively less conspicuous landscape features and have been inconsistently treated, sometimes as wetlands and at other times ignored. It is not unexpected when eastern wetland workers show relatively little interest in distinguishing riparian systems and their diverse communities.

While we obviously agree with the current consensus among western workers that riparianlands are technically wetlands, we see no compelling reason to stress unduly the reality nor argue the point. Rather, we would stress that riparian systems are intermediate in ecological and evolutionary position between the purely aquatic and purely terrestrial systems and overlap both of them in varying degrees. Undeniably the three--Aquatic, Riparian, Terrestrial--are distinctive natural systems that harbor peculiarly obligate species structured into distinctive biotic communities across all of North America.

#### LITERATURE CITED

- Brown, B. T., S. W. Carothers, and R. R. Johnson. In press. Birds of the Grand Canyon Region. University of Arizona Press, Tucson, Ariz.
- Campbell, C. J., and W. Green. 1968. Perpetual succession of streamchannel vegetation in a semiarid region. *J. Ariz. Acad. Sci.* 5(2): 86-98.
- Cowardin, L. M., V. Carter, F. C. Golet, and E. T. LaRoe. 1979. Classification of wetlands and deepwater habitats of the United States. USDI U.S. Fish and Wldl. Serv. OBS. 103 pp.
- Hall, E. R. 1959. Zoogeography. p. xxiii-xxx. In E. R. Hall and K. R. Kelson. *The Mammals of North America*. Ronald Press, New York, N.Y. 2 vols.
- Johnson, R. R. 1979a. The lower Colorado River: a western system. p. 41-55. In R. R. Johnson and J. F. McCormick (tech. coord.), *Strategies for protection and management of floodplain wetlands and other riparian ecosystems*. USDA Forest Service General Technical Report WO-12, 410 p. U.S. Dept. Agriculture, Washington, D.C.
- Johnson, R. R. 1979b. Foreword. p. ii. In R. R. Johnson and J. F. McCormick (tech. coord.), *Strategies for protection and management of floodplain wetlands and other riparian ecosystems*. USDA Forest Serv. Gen. Tech. Rpt. WO-12, 410 p. U.S. Dept. Agriculture, Washington, D.C.
- Johnson, R. R., S. W. Carothers, and J. M. Simpson. 1984a. A riparian classification system. p.375-382. In R. E. Warner and K. M. Hendricx (Ed.), *California riparian systems*. University of California Press, Berkeley, Calif. 1035 p.
- Johnson, R.R., P. L. Warren, L. S. Anderson, and C. H. Lowe. 1984b. Stream order in ephemeral watercourses: A preliminary analysis from the Sonoran Desert. p. 89-100. In *Hydrology and Water Resources in Arizona and the Southwest*, Vol. 14, Office of Arid Lands Studies, University of Arizona, Tucson.
- Leopold, A. 1933. *Game management*. C. Scribners' Sons, New York, N.Y. 481 p.
- Lowe, C. H., Jr. 1961. Biotic communities in the sub-Mogollon region of the inland Southwest. *J. Ariz. Acad. Sci.* 2(1):40-49.
- Lowe, C. H. 1964. Arizona Landscapes and habitats. p. 1-132. In *The vertebrates of Arizona*. University of Ariz. Press, Tucson. 270 p.
- Merriam, C. H. 1890. Results of a biological survey of the San Francisco Mountains region and desert of the Little Colorado in Arizona. *USDA, N. Amer. Fauna*, 3:1-136.
- Merriam, C. H. 1898. Life-zones and crop-zones or the United States. *USDA, Div. Biol. Sur. Bull.* 10:1-79.
- Minckley, W. L., and D. E. Brown. 1982. Wetlands. p. 223-287. In D. E. Brown (Ed.), *Biotic communities of the American Southwest--United States and Mexico*. *Desert Plants* 4(1-4):1-342.
- Odum, E. 1979. Opening address: Ecological importance of the riparian zone. p. 2-4. In R. R. Johnson and J. F. McCormick (tech. coord.) *Strategies for the protection and management of floodplain wetlands and other riparian ecosystems*. USDA Forest Serv. Gen. Tech. Rpt. WO-12, 410 p. U.S. Dept. Agric., Washington, D.C.

- Phillips, A. R., J. T. Marshall, and G. Monson. 1964. The birds of Arizona. The University of Arizona Press, Tucson. 220 p.
- Swanson, F. J., S. V. Gregory, J. R. Sedell, and A. G. Campbell. 1982. Land-water interactions: The riparian zone. In E. L. Edmonds, Analysis of coniferous forest ecosystems in the western United States. US/IBP Synthesis Series 14. Hutchinson Ross Publishing Co., Stroudsburg, Pennsylvania.
- Warner, R. E. 1984. Some riparian definitions. p. xxv-xxvi. In R. E. Warner and K. M. Hendrix (Ed.), California riparian systems, University of California Press, Berkeley. 1035 p.
- Whittaker, R. H., and W. A. Niering. 1965. Vegetation of the Santa Catalina Mountains, Arizona: a gradient analysis of the south slope. Ecology 46:429-452.
- Whittaker, R. H., and W. A. Niering. 1968. Vegetation of the Santa Catalina Mountains, Arizona. IV. Limestone and acid soils. J. of Geology 56:523-544.



# Influence of Agriculture on Waterbird, Wader, and Shorebird Use Along the Lower Colorado River<sup>1</sup>

Robert D. Ohmart<sup>2</sup>, Bertin W. Anderson<sup>3</sup>, and

William C. Hunter<sup>4</sup>

---

Abstract.--Waterbird, wader, and shorebird use of the Colorado River was restricted to habitats in or immediately adjacent to the river prior to agricultural development. We studied agricultural habitats systematically for three years and identified those agricultural settings that were most important for individual species and groups of waterbirds, waders, and shorebirds.

---

## INTRODUCTION

The importance of riparian habitats to wildlife and their rapid disappearance in the western states has received much attention over the past 10 years. Conversion of riparian habitats to agricultural land accounts for a major portion of the loss of riparian habitats. Yet, agricultural habitats have received little attention with regard to wildlife values, with the exception of studies on interfacing agriculture-riparian situations (Carothers et al. 1974, Conine et al. 1978) and a more comprehensive study of the influence of agriculture on wildlife in the lower Colorado River valley (Anderson and Ohmart 1982). From the latter study, we report here on the factors that influence waterbird, wader, and shorebird use of agricultural areas of the lower Colorado River valley.

Although many terrestrial riparian bird species have suffered from heavy habitat loss in the conversion of land to agricultural production in the lower Colorado River valley (approximately 120,000 ha since 1890), several groups of species using agricultural habitats have increased. Waterbirds, waders, and shorebirds are among the species that have benefitted from or at least make use of agricultural features. Most waterbirds and

waders are associated with open water and marsh habitats which, like agricultural areas, have increased substantially since the beginning of the 20th century (Ohmart et al. 1977). Many of these species make use of both aquatic and agricultural areas for roosting and foraging, respectively. Geese, cranes, and several heron species are examples. In addition, shoreline and sandbars are very local in distribution; whereas, agricultural areas have proven to be among the most productive habitats for finding and studying many transient and resident shorebird species on the lower Colorado River (Anderson and Ohmart 1984).

We describe agricultural features most associated with occurrence of waterbirds, waders, and shorebirds. We report habitat use by presence/absence criteria because of the erratic occurrences of some agricultural features, the flocking tendencies of some species vs. the solitary nature of others, and the overall low densities of many species treated here. Finally, we examine the minimum range of agricultural features necessary to maximize use of an area by waterbirds, waders, and shorebirds in the lower Colorado River valley.

## METHODS

The general study area includes agricultural land in southwestern Arizona and southeastern California. Five localities were studied; these included the Wellton-Mohawk and Imperial-Coachella valleys, the Mohave and Colorado River Indian Reservations, and Cibola National Wildlife Refuge (Anderson and Ohmart 1982). The latter three sites are directly adjacent to the lower Colorado River.

Birds were censused along 23 4.8-km transects three times per month. Agricultural land along each transect was subdivided into 0.2- or 0.4-km sections; each section usually represented a dis-

---

<sup>1</sup>Paper presented at the Riparian Ecosystems and Their Management: Reconciling Conflicting Uses Conference. [University of Arizona, Tucson, April 16-18, 1985].

<sup>2</sup>Robert D. Ohmart is an Associate Director of the Center for Environmental Studies at Arizona State University, Tempe, Ariz.

<sup>3</sup>Bertin W. Anderson is a Research Associate of the Center for Environmental Studies at Arizona State University, Tempe, Ariz.

<sup>4</sup>William C. Hunter is a Graduate Research Assistant in the Center for Environmental Studies at Arizona State University, Tempe, Ariz.

tinct unit containing only one field type. Sampling included the area within 0.2 km lateral to each side of the transect, and the total number of hectares censused was calculated. In addition, we measured the extent of inhabited areas, margins, canals, and feedlots.

Major crop types included cotton, alfalfa, grass, wheat, and milo. In addition, fields growing lettuce, squash, tomatoes, onions, and melons were grouped under the category of truck crops because they are structurally similar, and cultivation and harvesting techniques are similar. When a field was being changed from one crop type to another, it often was cleared; such fields were referred to as plowed. Each field type was categorized as to whether or not it was irrigated and whether the crop was > or <25 cm tall.

Waterbirds and waders were censused monthly from March 1978 through October 1980. The number of times each crop/feature type was censused and the number of times each species was present in the field type was tabulated. A significant number of occurrences in a given situation was determined by finding the proportion of that feature among the total crop/feature occurrences. This proportion was the number of times a species would be expected to have been recorded in that situation if its occurrence was purely random. A significant association between the species and the crop/feature was defined as those cases where the number of occurrences within a particular situation was significantly larger than expected at  $P < 0.05$ . The number expected was the proportion of the crop/feature occurrences in the total pool of crops and features multiplied by the total number of occurrences of the species. This approach identified important crops and features for each species, and general trends among species groups were defined to maximize agricultural use by birds.

Shorebird occurrences were tabulated for March-May (vernal migration) and July-October (autumnal migration) during 1978, 1979, and 1980. These months were periods of peak occurrence for most species. Shorebird associations with crop/feature types were identified for each species as determined for waterbirds and waders. Additional analysis was used to determine overall use of crop/features by shorebirds. We determined if the number of fields with shorebirds was significantly larger or smaller than would be expected by chance ( $P < 0.05$ ) for each crop/feature type. Lastly, we determined if there was a greater use of either irrigated or nonirrigated fields across all crop types from a random distribution ( $P < 0.05$ ) for each shorebird species.

## RESULTS

### Crop/Feature Types

The most often encountered crop/feature types include, in order of highest-to-lowest frequency of occurrence, margins, nonirrigated plowed, nonirrigated alfalfa >25 cm, nonirrigated alfalfa <25 cm, and nonirrigated cotton >25 cm (table 1).

Table 1.--Number of times each field type occurred (4 ha or more) on agricultural censuses for waterbirds and waders (full three years) and shorebirds (migration periods only). N = times crop/feature censused; Prop. = proportion.

Crop/ feature	Irrigated	Waders and Waterbirds		Shorebirds	
		N	Prop. of total	N	Prop. of total
Plowed	Yes	73	0.017	54	0.032
	No	468	0.109	308	0.185
Alfalfa	>25 cm	55	0.013	34	0.020
	>25 cm	432	0.101	162	0.097
	<25 cm	49	0.011	21	0.013
	<25 cm	393	0.092	95	0.057
Cotton	>25 cm	75	0.018	57	0.034
	>25 cm	388	0.091	220	0.132
	<25 cm	23	0.005	12	0.007
	<25 cm	177	0.041	99	0.059
Milo	>25 cm	11	0.003	--	--
	>25 cm	48	0.011	--	--
	<25 cm	0	0.000	--	--
	<25 cm	16	0.004	--	--
Wheat	>25 cm	22	0.005	25	0.015
	>25 cm	163	0.038	121	0.072
	<25 cm	15	0.004	18	0.010
	<25 cm	148	0.035	51	0.031
Truck crop	>25 cm	6	0.001	3	0.002
	>25 cm	51	0.012	29	0.017
	<25 cm	9	0.002	2	0.001
	<25 cm	82	0.019	23	0.015
Grass	>25 cm	10	0.002	7	0.004
	>25 cm	107	0.025	70	0.042
	<25 cm	14	0.003	14	0.008
	<25 cm	132	0.031	62	0.037
Canal	---	165	0.039	182	0.109
Margins	---	496	0.116	--	--
Inhabited	---	88	0.021	--	--

Percentage of irrigated field types for the entire census period was 8.4%, and during the period of shorebird censusing the percentage was 14.6%. Milo, margins, and inhabited areas were not used by any shorebirds so were not included in analysis for this species group.

### Wading Birds

The Great Egret (Casmerodius albus), Great Blue Heron (Ardea herodias), Green-backed Heron (Butorides striatus), and Snowy Egret (Egretta thula) were associated with canals far more than with any other agricultural feature (table 2). Of these species, the Green-backed Heron was the only heron to be largely restricted to canals with this

Table 2.--Fields in which use by wading birds was significantly ( $P < 0.05$ ) greater than expected with a random distribution. IR = irrigated; NI = not irrigated; > = height greater than 25 cm; < = height less than 25 cm; + indicates presence in crop/feature but not significantly associated with it. Not all field types are represented, only those are shown that had at least one species significantly associated with it.

Species	Total occurrences	Canals	Percent of total occurrences											Total % sign. assoc.
			Alfalfa				Plowed		Milo		Grass			
			<IR	<NI	>IR	>NI	IR	NI	>NI	<IR	>IR	<IR	<NI	
Great Egret	109	55	+	15	+	+	-	-	-	-	-	-	-	70
Great Blue Heron	64	56	+	17	+	+	-	-	-	-	-	-	-	73
Green-backed Heron	37	81	-	-	-	-	-	-	-	-	-	-	-	81
Snowy Egret	26	19	8	+	4	+	-	-	-	-	+	4	-	35
Cattle Egret ( <i>Bubulcus ibis</i> )	109	+	+	4	6	+	6	+	-	-	4	6	15	41
White-faced Ibis ( <i>Plegadis chihi</i> )	15	+	33	-	7	-	20	-	-	-	+	7	-	67
Sandhill Crane ( <i>Grus canadensis</i> )	74	-	+	20	+	24	+	19	8	4	+	-	-	75

feature accounting for 81% of its total occurrence in agricultural areas. Snowy and Cattle egret distributions were closest to a random distribution across available agricultural features among wading species.

The Cattle Egret, White-faced Ibis, and Sandhill Crane were not significantly associated with canals (table 2). The Cattle Egret was significantly associated with plowed, alfalfa, and grass fields, but it did not matter whether the fields were irrigated or not. In contrast, the wintering Sandhill Crane occurred almost exclusively in nonirrigated alfalfa, plowed, and milo fields; whereas, at the other extreme, the migratory White-faced Ibis occurred only in irrigated alfalfa, plowed, and grass fields.

#### Waterbirds

Grebes, cormorants, coots, and diving ducks (pochards and mergansers) were overwhelmingly associated with canals (table 3). Geese were associated exclusively with plowed, alfalfa, milo, wheat, and grass fields, with all but the Snow Goose occurring largely in nonirrigated fields. Puddle ducks were associated both with canals and irrigated crops with two species (American Wigeon and Northern Pintail) occurring only in irrigated fields.

Nineteen of the 25 species treated under this category have 100% of their occurrences associated significantly with one or more agricultural crop/feature types. However, three species (Snow Goose, Mallard, and Northern Pintail) have less than 60% of their occurrences associated significantly with some agricultural crop/feature and thus have a more random distribution in agricultural habitats. Agricultural situations were most

important to puddle ducks and geese, given the number of occurrences compared with other species within this group.

#### Shorebirds

Fifteen of 17 species of shorebirds were significantly associated with irrigated plowed fields (table 4). In addition, four species each were significantly associated with nonirrigated plowed, irrigated and nonirrigated grass <25 cm; three species with irrigated wheat >25 cm; two species each with nonirrigated alfalfa <25 cm, irrigated and nonirrigated grass >25 cm, and canals. Significant associations with field types were restricted to plowed fields for nine species with all but two of these only with irrigated plowed fields (the exceptions were Black-bellied Plover and Mountain Plover). Common Snipe and Spotted Sandpiper were associated most significantly with canals over all other crop/features.

Eight species occurred significantly more often in irrigated than in nonirrigated fields (table 4). Four species occurred significantly more often in nonirrigated than in irrigated fields. Overall, there were 26 significant associations between shorebirds and irrigated fields and 12 with nonirrigated fields, with eight species significantly associated with at least one each irrigated and nonirrigated crop/feature type.

All shorebird occurrences together indicated that they were found more often than expected by chance alone in irrigated and nonirrigated plowed, irrigated grass >25 cm and <25 cm, irrigated wheat >25 cm, and canals (table 5). Shorebirds occurred less often than expected by chance alone in nonirrigated alfalfa >25 cm, irrigated and nonirrigated cotton >25 cm, and nonirrigated cotton

Table 3.--Agricultural crops and features with which grebes, cormorants, coots, ducks, and geese were associated with a frequency greater than expected with a random distribution. Abbreviations, symbols, and notes as in table 2.

Species	Total occurrences	Canals	Percent of total occurrences												Total % sign. assoc.
			Plowed		Alfalfa				Milo		Wheat		Grass		
			IR	NI	>IR	>NI	<IR	<NI	>IR	>NI	<IR	<NI	>IR	<IR	
Pied-billed Grebe ( <i>Podilymbus podiceps</i> )	3	100	-	-	-	-	-	-	-	-	-	-	-	-	100
Eared Grebe ( <i>Podiceps nigricollis</i> )	1	100	-	-	-	-	-	-	-	-	-	-	-	-	100
Double-crested Cormorant ( <i>Phalacrocorax auritus</i> )	1	100	-	-	-	-	-	-	-	-	-	-	-	-	100
American Coot ( <i>Fulica americana</i> )	9	100	-	-	-	-	-	-	-	-	-	-	-	-	100
Common Merganser ( <i>Mergus merganser</i> )	12	100	-	-	-	-	-	-	-	-	-	-	-	-	100
Red-breasted Merganser ( <i>M. serrator</i> )	3	100	-	-	-	-	-	-	-	-	-	-	-	-	100
Bufflehead ( <i>Bucephala albeola</i> )	2	100	-	-	-	-	-	-	-	-	-	-	-	-	100
Common Goldeneye ( <i>B. clangula</i> )	15	80	-	-	-	-	-	-	-	-	-	-	-	-	80
Total Mergini	32	91	-	-	-	-	-	-	-	-	-	-	-	-	91
Greater Scaup ( <i>Aythya marila</i> )	1	100	-	-	-	-	-	-	-	-	-	-	-	-	100
Lesser Scaup ( <i>A. affinis</i> )	4	100	-	-	-	-	-	-	-	-	-	-	-	-	100
Redhead ( <i>A. americana</i> )	4	25	50	-	-	-	-	-	-	-	-	-	25	-	100
Ring-necked Duck ( <i>A. collaris</i> )	3	100	-	-	-	-	-	-	-	-	-	-	-	-	100
Total pochards	12	75	17	-	-	-	-	-	-	-	-	-	8	-	100
Wood Duck ( <i>Aix sponsa</i> )	1	100	-	-	-	-	-	-	-	-	-	-	-	-	100
Cinnamon Teal ( <i>Anas cyanoptera</i> )	63	56	16	-	5	-	6	-	3	-	-	-	-	-	86
Blue-winged Teal ( <i>A. discors</i> )	5	60	-	-	20	-	-	-	-	-	-	-	-	-	80
Green-winged Teal ( <i>A. crecca</i> )	15	47	40	-	-	-	-	-	7	-	7	-	-	-	100
Northern Shoveler ( <i>A. clypeata</i> )	3	33	67	-	-	-	-	-	-	-	-	-	-	-	100
Mallard ( <i>A. platyrhynchos</i> )	12	25	33	-	-	+	-	+	-	-	-	+	-	-	58
American Wigeon ( <i>A. americana</i> )	6	-	83	-	-	-	-	-	-	-	-	17	-	-	100
Northern Pintail ( <i>A. acuta</i> )	27	-	48	-	-	+	-	+	7	-	+	-	-	4	59
Total puddle ducks	131	38	31	-	-	-	5	-	4	-	-	-	-	-	78
Canada Goose ( <i>Branta canadensis</i> )	30	-	-	30	-	23	-	27	3	7	-	-	-	-	90
Brant ( <i>B. bernicla</i> )	1	-	-	-	-	-	-	100	-	-	-	-	-	-	100
Greater White-fronted Goose ( <i>Anser albifrons</i> )	1	-	-	-	-	-	-	100	-	-	-	-	-	-	100
Ross Goose ( <i>Chen rossii</i> )	2	-	-	-	-	-	-	100	-	-	-	-	-	-	100
Snow Goose ( <i>C. caerulescens</i> )	9	-	11	+	-	+	11	+	-	+	-	+	-	-	22
Total geese	43	-	-	24	-	22	-	36	2	4	-	-	-	-	88

Table 4.--Agricultural crops and features with which shorebirds were associated with a frequency greater than expected with a random distribution on transects. Abbreviations, symbols, and notes as in table 2.

Species	Total occurrences	Percent of total occurrences											All crop/features	
		Plowed		Alfalfa		Grass				Wheat		Percent accounted for by crop/features	IR	NI
		IR	NI	<NI	>IR	>NI	<IR	<NI	>IR	Canals				
Black-bellied Plover ( <i>Pluvialis squatarola</i> )	19	42	37	-	+	+	-	-	-	-	-	79	+	+
Killdeer ( <i>Charadrius vociferus</i> )	287	11	+	10	+	+	+	+	4	+	-	25	+	68
Mountain Plover ( <i>C. montanus</i> )	16	25	63	-	-	-	-	-	-	-	-	88	+	69
Black-necked Stilt ( <i>Himantopus mexicanus</i> )	28	25	+	+	11	-	7	11	-	-	-	54	+	+
American Avocet ( <i>Recurvirostra americana</i> )	9	67	+	-	-	-	+	-	-	-	-	67	78	+
Greater Yellowlegs ( <i>Tringa melanoleuca</i> )	36	30	-	-	10	5	8	-	-	-	-	53	+	+
Lesser Yellowlegs ( <i>T. flavipes</i> )	6	50	+	+	-	-	-	-	-	-	-	50	+	+
Willet ( <i>Catoptrophorus semipalmatus</i> )	18	39	+	-	-	-	+	+	+	+	+	39	+	+
Spotted Sandpiper ( <i>Actitis macularia</i> )	29	+	-	-	-	-	-	-	-	-	-	83	100	-
Whimbrel ( <i>Numenius phaeopus</i> )	45	36	+	+	4	9	4	22	-	-	-	75	75	+
Long-billed Curlew ( <i>N. americanus</i> )	53	11	27	13	+	+	8	19	+	-	-	78	+	68
Western Sandpiper ( <i>Calidris mauri</i> )	10	40	+	-	-	-	-	-	-	+	-	40	70	+
Least Sandpiper ( <i>C. minutilla</i> )	61	30	+	+	+	-	+	+	18	+	-	48	64	+
Long-billed Dowitcher ( <i>Limnodromus scolopaceus</i> )	27	41	+	+	+	+	-	-	+	-	-	41	63	+
Common Snipe ( <i>Gallinago gallinago</i> )	17	+	-	-	-	+	-	-	12	59	-	71	82	+
Wilson Phalarope ( <i>Phalaropus tricolor</i> )	8	38	-	-	+	-	+	-	-	+	-	38	88	+
Ring-billed Gull ( <i>Larus delawarensis</i> )	37	30	46	+	+	+	+	+	-	-	-	76	+	65

Table 5.--Overall shorebird use of agriculture by numbers of species and all shorebirds combined. Irr. = irrigated; Pres. = present; Sign. assoc. = significantly associated; Obs. = observed; Exp. = expected; NS = not significant.

Crop/ feature	Number of species		Fields with shorebirds		Binomial P	
	Irr.	Pres.	Sign. assoc.	Obs.		Exp.
Plowed						
--	Yes	17	15	32	12.5	+<0.001
--	No	13	4	130	72.3	+<0.001
Alfalfa						
>25 cm	Yes	5	0	8	7.8	NS
>25 cm	No	7	0	18	37.9	-<0.001
<25 cm	Yes	8	0	9	5.1	NS
<25 cm	No	8	2	23	22.3	NS
Cotton						
>25 cm	Yes	5	0	7	13.3	-<0.05
>25 cm	No	4	0	9	51.6	-<0.001
<25 cm	Yes	4	0	3	2.7	NS
<25 cm	No	2	0	6	23.1	-<0.001
Grass						
>25 cm	Yes	9	2	3	1.2	NS
>25 cm	No	9	2	12	16.8	NS
<25 cm	Yes	11	4	10	2.4	+<0.001
<25 cm	No	8	4	21	16.8	+<0.025
Truck						
>25 cm	Yes	1	0	2	0	NS
>25 cm	No	1	0	6	7.4	NS
<25 cm	Yes	1	0	1	0	NS
<25 cm	No	3	0	4	5.9	NS
Wheat						
>25 cm	Yes	6	3	12	5.9	+<0.01
>25 cm	No	7	0	12	28.2	-<0.001
<25 cm	Yes	4	0	2	3.9	NS
<25 cm	No	2	0	7	12.1	NS
Canals						
--	--	7	2	59	42.6	+<0.01

<25 cm. The most abundant field types were usually not the places where shorebirds occurred most frequently. Although cotton fields were avoided largely by shorebirds, these fields indirectly enhanced shorebird habitat because they were periodically plowed and attracted significant numbers of shorebirds. Overall, shorebird occurrence in agricultural areas was related to routine agricultural practices (plowing, irrigation) and with the presence of canals. However, 12 of the 17 species preferred either irrigated or nonirrigated fields and did not randomly occur in both situations. In order to maximize diversity of shorebirds, a mosaic of irrigated and nonirrigated fields are desirable.

#### DISCUSSION

As Orians (1975) has stated, there is a need to study organisms that have been exposed to perturbation resulting from the unprecedented modifica-

tion of the environment by humans. Clearing of land for agricultural purposes creates new habitat for species that previously may not have occurred in the area while, at the same time, destroying habitat that may cause the original fauna to disappear unless these latter species are able to take advantage of the new situation. All of the species treated here have increased in their occurrence in the valley since the 1800's due largely to the activities of man, including agricultural practices, storage of water in large reservoirs (primarily for irrigation), and creation of stable marshlands.

Grinnell (1914) described the lower Colorado River's aquatic and semiaquatic avifauna as depauperate; he recorded few species and low numbers of herons, waterfowl, and shorebirds north of the Gila-Colorado river confluence. Presently, all of these species occur in rather stable numbers responding to the food resources provided by agricultural areas, roosting and foraging sites of open water areas, and/or a combination of these. The vast majority of species treated here are transient and winter visitors and do not depend on agricultural areas for nesting. Exceptions are Killdeer and a few Cinnamon Teal.

Cranes and geese are almost totally dependent on agricultural areas for foraging. On the three lower Colorado River national wildlife refuges, recent increases in abundance for both cranes and geese are attributed to managing aquatic or semiaquatic roosting sites with adjacent agricultural foraging sites (mostly alfalfa and milo fields). Shorebird, waterbird, and wading species associated with irrigated fields must track this resource as flooded fields are infrequent and ephemeral. Flooding of fields attracts not only species treated here, but also swallows, water pipits, and blackbirds, which flock to feed on invertebrates displaced by irrigation water. Waterbird and some wading species (especially Green-backed Herons) find more stable foraging sites in the extensive canal systems, especially along larger dirt-banked canals that usually have a constant flow of water. Spotted Sandpipers and some waterbirds use the more sterile cement-lined canals to a greater extent.

Several species treated here have undoubtedly undergone range extensions directly associated with the expansion of agricultural practices. Most dramatic has been the expansion of the Cattle Egret, originally introduced from the Old World into the New World Tropics. This species became established in the southeastern United States in the 1950's and has spread north and west into areas of extensive agricultural and horticultural production. Cattle Egrets were first found on the lower Colorado River in 1970 and are on the verge of establishing several breeding colonies. Mountain Plovers and Whimbrels were considered casual in Arizona before the 1940's (Monson and Phillips 1981), but both species are now regular, and hundreds of individuals occasionally occur in agricultural situations.

Most, if not all, shorebirds have benefitted from various agricultural features on the lower Colorado River, although this region is not a major migration route for this group. However, shorebird

use of agriculture in regions where shorelines and estuaries have been extensively developed, such as in Florida and California, is in need of immediate attention, given the desperate situation outlined by Myers (1983) for this group. Our paper outlines important agricultural features for shorebird use that may be compared with data collected in other regions.

Of all the habitat changes experienced in the lower Colorado River valley, as well as many other major southwestern riparian systems, the conversion of vast areas to agricultural production is certainly the most dramatic. The abundant foods provided by agricultural habitats benefit a wide variety of birds that can opportunistically use them. Since nesting sites are not a concern for many of these species on the lower Colorado River, they may attain relatively high densities. If survival has been high in these overwintering or migratory individuals, then the population biology of these species may be changing, with effects perhaps evident on their northerly breeding grounds. Although a number of species are benefitting from the development of agriculture, the future of many riparian species in agricultural areas is not optimistic unless a mosaic of native riparian habitats and developed lands is managed for conserving both the original and new avifaunas.

#### ACKNOWLEDGMENTS

The development of this work and the agricultural study as a whole was aided by George F. Drake and Kathleen Conine. Mark Kasprzyk and Camille Romano organized and accomplished much of the original data analysis. We thank the many dedicated biologists who assisted in data collection and analysis. Editorial assistance was provided by Jane R. Durham and Cindy D. Zisner. Cindy D. Zisner also typed the manuscript. This study was supported by U.S. Bureau of Reclamation Contract No. 8-07-30-X0027.

#### LITERATURE CITED

Anderson, B. W., and R. D. Ohmart. 1982. The influence of the interspersed agriculture and natural habitats on wildlife in southern

- California and western Arizona. U.S. Bureau of Reclamation, 316 p. Lower Colorado Region, Boulder City, Nev.
- Anderson, B. W., and R. D. Ohmart. 1984. Vegetation management study for the enhancement of wildlife along the lower Colorado River. Comprehensive final report to U.S. Bureau of Reclamation, 529 p. Lower Colorado Region, Boulder City, Nev.
- Carothers, S. W., R. R. Johnson, and S. W. Aitchison. 1974. Population structure and social organization of southwestern riparian birds. *American Zoologist* 14:97-108.
- Conine, K. H., B. W. Anderson, R. D. Ohmart, and J. F. Drake. 1978. Responses of riparian species to agricultural habitat conversions. p. 248-262. *In* Strategies for protection and management of floodplain wetlands and other riparian ecosystems. Proceedings of the symposium. [Callaway Gardens, Ga., December 11-13, 1978] USDA Forest Service General Technical Report WO-12, 410 p. USDA Forest Service, Washington, D.C.
- Grinnell, J. 1914. An account of the mammals and birds of the lower Colorado River Valley with especial reference to the distributional problems presented. University of California Publications in Zoology 12:51-294.
- Monson, G., and A. R. Phillips. 1981. Annotated checklist of birds of Arizona, Second edition. University of Arizona Press, Tucson, Ariz. 240 p.
- Myers, J. P. 1983. Conservation of migratory shorebirds: staging areas, geographic bottlenecks, and regional movements. *American Birds* 37:23-25.
- Ohmart, R. D., W. O. Deason, and C. Burke. 1977. A riparian case history: the Colorado River. p. 35-47. *In* Importance, preservation and management of riparian habitat: a symposium. Proceedings of the symposium. [Tucson, Ariz., July 9, 1977] USDA Forest Service General Technical Report RM-43, 217 p. Rocky Mountain Forest and Range Experiment Station, Fort Collins, Colo.
- Orians, G. H. 1975. Diversity, stability and maturity in natural ecosystems. p. 139-151. *In* W. H. van Dobber and R. H. Lowe, eds., *Unifying Concepts in Ecology*. W. Junk, The Hague, Holland.

# Managing Riparian Vegetation and Wildlife Along the Colorado River: Synthesis of Data, Predictive Models, and Management<sup>1</sup>

Bertin W. Anderson<sup>2</sup> and Robert D. Ohmart<sup>3</sup>

---

Abstract.--Predictive models were developed from data collected monthly on vegetation and wildlife for over seven years (1972-1979) in order to design wildlife enhancement projects. Implementation of projects was conducted between 1979-1981 to gain information on costs, develop methodologies on revegetation, and to test model-generated predictions.

---

## INTRODUCTION

We began ecological studies along the lower Colorado River in 1972 to explore the possibility of managing riparian vegetation in order to (1) reduce total water loss caused by evapotranspiration, (2) reduce total floodplain vegetation so that flood flows could pass relatively unimpeded, (3) blend items (1) and (2) with wildlife enhancement, and (4) explore the economic and technical feasibility of revegetating relatively large areas. We summarize our findings and discuss predictive models that have emanated from our work over the past decade. Detailed analyses are not presented, but pertinent references are cited.

## THE DATA BASE

Riparian vegetation along the lower Colorado River encompassed some 40,000 ha when our work began. Initially, the Bureau of Reclamation, the funding agency, decided that the study would require three years; one year for planning and two years for intensive field work. Soon they rendered the wise decision to extend the intensive field work phase by two additional years. The field work was to provide an in-depth data base for showing more clearly the relationships between riparian vegetation and densities of wildlife associated with these habitats (table 1).

---

<sup>1</sup>Paper presented at the Riparian Ecosystems and Their Management: Reconciling Conflicting Uses Conference. [University of Arizona, Tucson, April 16-18, 1985].

<sup>2</sup>Bertin W. Anderson is a Research Associate of the Center for Environmental Studies at Arizona State University, Tempe, Ariz.

<sup>3</sup>Robert D. Ohmart is an Associate Director of the Center for Environmental Studies at Arizona State University, Tempe, Ariz.

After analysis, terrestrial vegetation was divided into 23 habitats based on the vertical configuration of the vegetation and on the numerically dominant vegetation present within a stand. Stand size ranged from 10 to 40 ha with the vast majority of stands occupying 20 ha. Each stand was classified as belonging to one of the 23 habitats (Anderson et al. 1983, Anderson and Ohmart 1984).

## Vegetation Classification

We developed a classification system that was easy to remember and apply in the field with few needed plant community measurements, or one that someone very familiar with the system could use to make a good field estimate with no needed measurements. We recognized only six different vertical configurations and only six divisions on the basis of numerically dominant vegetation. The ultimate classification of a stand involved two steps: (1) determining the vertical configuration, and (2) determining the dominant plant species. Each of these steps required specific recall of only six relatively easy-to-remember categories (Anderson et al. 1983, Anderson and Ohmart 1984).

## Wildlife Densities

### Birds

Densities were obtained by censusing birds in each stand three times each month. A density estimate for each species was made on the basis of these three censuses. Density estimates for each of the habitat types was the average density of the stands representing that habitat for a given month and also across months for a given season. Averaging bird densities resulted in masking some of the variance in the data. However, we felt that most of this variance was due to highly localized edaphic features associated with each stand rather than any fundamental difference in

Table 1. Summary of data used to construct three predictive models, the kinds of predictions they make, and the tests made to determine their general level of accuracy.

Model	baseline data	Output	Model testing
I	A. Vegetation data from 23 habitats within 40,000 ha of riparian vegetation along the lower Colorado River.	Species richness values and densities of rodents and birds by season with confidence limits.	Three times on the lower Colorado River. Performance: poor to excellent depending on species or guild involved; poor to excellent for most species.
	B. Bird and rodent species richness and relative density estimates for all species from 23 habitats seasonally for five years (3,600 censuses each year).		
II	A. Number of times each of 59 wildlife categories ranked among the top three for the 23 habitats. These data are determined from A and B above.	A quick method for estimating impact of perturbation; estimates of the extent to which revegetation offsets losses incurred.	Twice on the lower Colorado River. Performance: satisfactory to good.
	B. Correlation between the number of wildlife categories ranked among the top three for each habitat and the number of cottonwood ( <u>Populus fremontii</u> ), willow ( <u>Salix gooddingii</u> ), and honey mesquite ( <u>Prosopis glandulosa</u> ) trees present.		
	C. Relationship between mortality and biomass production for the species in B.		
III	A. Relationship of tree height growth, biomass production, and tree mortality to depth of tillage, soil type, and soil salinity for 608 honey mesquite, 930 cottonwood, 1258 willow, and 300 blue palo verde ( <u>Cercidium floridum</u> ) trees.	Estimates of tree growth, biomass production, and survival after three years for cottonwood, willow, honey mesquite, and blue palo verde trees.	Five tests on the lower Colorado River and a test in progress on Rio Grande in Texas. Performance: high accuracy in all categories for all species.
	B. Soil classification every 0.3 m, salinity and extent of tillage at each planting site for each species in A.		



bird use between stands within a habitat (Anderson et al. 1983). This point is discussed further below. Data by habitat type for each season is presented in Anderson and Ohmart (1977).

#### Rodents

Nocturnal rodent populations were sampled annually by snap-trapping in all habitats several times during the cool (October-March) and warm (May-September) months. Relative species densities were expressed as the number caught per 270 trap nights (the summation of trap nights per trapping season). Species richness and relative densities of rodents were obtained for all habitat types for five years.

### MODEL I

#### Relationships Between Wildlife and Vegetation

The first step in determining the relationship of bird and rodent community attributes with the vegetation was to subject the vegetation data to principal components analysis (PCA) to obtain the major independent trends in the data (i.e., principal components [PC's]). These independent trends were treated as plant community variables. An alternative would have been to use the original variables in subsequent analyses. Had we chosen to do this, we would have undoubtedly arrived at most of the same conclusions. We chose PCA because many of the original variables were significantly intercorrelated. This would have made interpretation of results a slow and tedious process had we chosen to use the original variables rather than variables derived through PCA (Anderson et al. 1983, Anderson and Ohmart 1984).

In the next step, we developed regression equations to show the relationship between bird community attributes such as species richness, bird species diversity, density of visiting insectivores, etc., as well as densities of each species to the four derived vegetation variables. This was repeated each season for each of five years. Similar calculations were made for rodents during the cool and warm times of year. Some of these analyses are presented in Anderson et al. (1983), Meents et al. (1983), and Anderson and Ohmart (1985).

These analyses were all by habitat, which, as pointed out above, concealed some of the variance in the stand-by-stand data because of averaging. It was possible that averaging concealed many important bird-vegetation and rodent-vegetation associations. To be certain that this procedure did not lead to incorrect conclusions the data were reanalyzed with entirely different statistical procedures and on a stand-by-stand basis, thus exposing more of the variance in the data. Conclusions from these analyses were nearly identical to those at the habitat level (Anderson et al. 1983, Rice et al. 1983a, b).

It was fortunate that we studied a significant proportion of the habitats available continuously over all seasons for five years. Had our sample,

through either time or space, been smaller, we might have arrived at a number of different conclusions, all wrong with respect to the complete five-year data set (Rice et al. 1983a, b, 1984; Anderson and Ohmart 1985).

#### Input Data

Vegetation data for 15 variables (foliage density for each of four strata, patchiness at these strata, foliage height diversity, number of shrubs, number of trees per ha for each of four species, number of trees with mistletoe [*Phoradendron californicum*] per ha) were used as input data. This information was included in the model and was used for calculating total foliage density, total patchiness, foliage height diversity, and, ultimately, for calculating a factor score for each of four PC's. These PC factor scores were then used to calculate predicted values for various wildlife species.

If measurements are not available for the whole range of variables or if no measurements were taken, then the person using the model (hereafter called the "user") has to enter which of the 23 habitat types is of particular interest. The model will then use factor scores for the average stand within this habitat type for predicting wildlife use.

It is possible that the user has calculated vegetation factor scores for a particular stand or wishes to manipulate factor scores to better understand the relationship between factor scores and wildlife use of an area. In this case, the user enters the factor scores to obtain wildlife values associated with those factor scores.

#### Output Data

Output data consist of predictions of the wildlife that will use the vegetation and, at the user's discretion, can consist of data for individual bird or rodent species for any season or all seasons, or it can consist of information such as total species richness, density of permanent resident insectivorous birds, density of visiting insectivorous birds, etc. The user has the option of retrieving all of this information for all or any single season or he can retrieve information for only the species in which he is particularly interested. The output consists of the five-year average from the original data base. Variation around this mean is also given.

#### Uses of Output

One of the major uses of the output is to aid in assessing impacts on wildlife of disturbances and for making management decisions. For example, if the user wishes to evaluate the impact that elimination of 30% of a stand of cottonwood-willow habitat would have on birds and nocturnal rodents, he enters the vegetation data for the undisturbed site and perturbs the site in the model. Then he can compare wildlife losses before and after perturbation, prior to any site modification. If the severity of loss is too great, the planners may decide to alter or reduce site disturbance.

If the modification is accepted, then the results will give guidelines for possible approaches to mitigation.

This model generates much detailed data that may not be of interest to a user who is concerned with only one or a few species. It could conceivably take hours or days to evaluate the output. At times it may be desirable to obtain information concerning the possible consequences of disturbances on the wildlife and to determine possible mitigation measures more quickly than is possible with this model. To meet this need, a second model was developed.

#### MODEL II

This model was designed to provide a very quick, but reasonable assessment of the impact that a particular action might have on wildlife. The model is based on the number of wildlife categories that ranked in the top three in a given habitat for each season (table 1). For example, if bird species richness in cottonwood-willow II ranked second in spring, this habitat would receive a score of 1. If bird species richness in this habitat ranked third in summer, the habitat score would increase by 1. Altogether, we considered 59 wildlife-seasonal categories (Anderson and Ohmart 1984:Table 13-1). Thus, a habitat in which all wildlife categories ranked in the top three across all seasons would receive a score of 59. The total was determined for each of the 23 habitats recognized. This information was then used in a correlation analysis involving the number of cottonwood, willow, and honey mesquite trees per unit area in each of 23 habitats.

The correlation between the number of high ranks for the various faunal components and the number of cottonwood-willow and honey mesquite trees was highly significant ( $R=0.86$ ,  $F=28.2$ ,  $df$  2,20,  $P<0.001$ ). Using the regression for this correlation gives the number of wildlife categories ranking in the top three for a given habitat is  $9.31\log_{10} CW/ha + 6.31\log_{10} HM/ha + (-0.9)$ . The number of categories ranked in the top three for each habitat is programmed into the model. The equation is used to calculate the number of categories occurring in the top three at various rates of revegetation. For example, if 40 ha of screwbean mesquite (*Prosopis pubescens*) IV are destroyed the loss is 7 (the number of categories ranked in the top three across a whole year). If 50% of the area is revegetated with 40 cottonwood and/or willow and 40 honey mesquite per 0.4 ha, there will be  $24.1(0.5)=12$  categories in the top three in the new habitat at or near maturity. This represents an enhancement of  $12/7 = 171 -100 = 71\%$ .

However, the above assumes that great care will be taken in the revegetation effort and that mortality of planted trees will not exceed 9%. Mortality decreases the value of the revegetation effort in two ways. First, any trees that die decrease the value of the mitigation effort. However, we have found that if soil conditions (soil type, layering, and salinity) cause the

death of some trees, it is unlikely that growth of the survivors will be unaffected. In fact, as mortality increases biomass production increases log linearly, which means that as mortality increases, biomass production of survivors will probably be severely restricted. Thus, a three-year-old cottonwood 4.5 m tall has roughly 30% of the biomass of a tree of the same age that was planted under ideal conditions and is 9 m tall.

#### Input

The user is first asked by the model to state which of the 23 habitats is to be considered, then he is asked whether or not the proportion of the cleared area that is to be revegetated is known. If these questions are answered affirmatively, the user is then asked to enter this information. If the questions are answered negatively, the user is asked what percent enhancement is desired. Finally, the user is queried as to how much mortality among planted trees would be considered acceptable.

#### Output

If the habitat is disturbed, the proportion of the area that will be revegetated, and the mortality rate for planted trees is acceptable, the model will then provide the percent enhancement that can be anticipated. If the percent enhancement desired is known, the model will indicate the proportion of the area that must be revegetated with tree density as prescribed by the user.

#### MODEL III

The third model that we have developed can be used for assessing the suitability of an area for revegetation. The user must enter the depth to which tillage will be provided, the electroconductivity of the soil relative to the depth of the water table, and whether competition from weeds or grass is expected to be a problem. Output is a prediction of mean growth, percent mortality, and percent of maximum biomass production after three years of growth. This information is provided for honey mesquite, blue palo verde, cottonwood, and willow.

This information is vital for determining the potential of an area when revegetating with the tree species mentioned above. Efficacy of the model is highly dependent upon quality of input data. If electroconductivity data comes from only two locations on a 40-ha plot, it is likely that model-generated predictions will be wrong. Similarly, if large samples are taken nonrandomly, model-generated predictions may be wrong. An adequate number of soil samples taken randomly over the site are essential data inputs.

#### TESTS OF THE MODELS

##### Wildlife Models

We have been conducting experimental revegetation work on a 35-ha plot since 1977 and on a

20-ha plot since 1980. Tests of predictions generated from models I and II indicate a satisfactory capability of our models to make accurate predictions (table 1). The wildlife models have also been thoroughly tested in a project involving experimental clearing. A total of more than 250 ha were included in this study, which extended over 42 months. Model predictions were found to be relatively accurate. Results from these tests are available in Anderson and Ohmart (1982, 1984, in press).

#### Vegetation Model

The model for tree growth was accurate to about 0.2 m for 150 cottonwoods with tillage to 3 m, the water table at 3.6 m, a soil salinity of 1.7 EC, and competition from weeds absent. The model was similarly accurate for 30 cottonwoods under the same conditions except with plant competitors present. The model was highly accurate for 20 honey mesquite and 130 cottonwood grown under highly saline conditions. Currently, we are testing predictions for 40 willows and 35 cottonwoods under conditions of low salinity, tillage to 2.6 m, water table at 2.9 m, and with little competition from weeds. All of these tests have been conducted in the floodplain of the lower Colorado River. A much larger test is under way along the Rio Grande in Texas. This study includes 100 fig (*Ficus* sp.), 100 fruiting mulberry (*Morus* sp.), 800 cottonwood, 200 willow trees, 300 quail bush (*Atriplex lentiformis*), and 300 wolfberry (*Lycium andersonii*) planted according to experimental design under a wide range of soil and salinity conditions. Some testing will also be done with the wildlife models.

#### CONCLUSIONS

We have studied several riparian systems in the desert Southwest over the past decade. Our studies on the Colorado River have been the most intensive and have led to the development of the above models. These models should be useful to individuals and agencies responsible for managing the riparian resource on the Colorado River. We believe that the effectiveness of our models is due mainly to the fact that our studies included sizeable samples through time and space. Similarly, the models based on experimental revegetation projects should have value in designing mitigation enhancement plans. Furthermore, if guidelines are followed (but, unfortunately, to date, they typically have not been) money and valuable time can be saved, i.e., trees will be planted only in areas where local biotic and abiotic factors are such that rapid growth, high biomass production, and high survival rate will maximize every dollar spent to insure enhancement or mitigation for wildlife.

Our Colorado River wildlife data have less value when their results are applied to other areas. Such attempts, if made without caution, could lead to egregious errors (e.g., see Hunter et al, this symposium). We are currently attempting to discover patterns that riparian habitats in

the desert Southwest may have in common. Once we have a good understanding of these patterns, then our revegetation models will apply over a broader range of riparian habitats.

#### ACKNOWLEDGMENTS

We would like to thank the many field biologists whose careful census efforts provided data for these analyses. Cindy D. Zisner typed the manuscript and she and Jane R. Durham provided editorial assistance. We especially thank the U.S. Bureau of Reclamation for their continued support of this long-termed study through Contract No. 7-07-30-V0009.

#### LITERATURE CITED

- Anderson, B. W., and R. D. Ohmart. 1977. Wildlife use and densities annual report. U.S. Bureau of Reclamation, Lower Colorado Region, Boulder City, Nev.
- Anderson, B. W., and R. D. Ohmart. 1982. Revegetation for wildlife enhancement along the lower Colorado River. U.S. Bureau of Reclamation, Boulder City, Nev.
- Anderson, B. W., and R. D. Ohmart. 1984. A vegetation management study for the enhancement of wildlife along the lower Colorado River. U.S. Bureau of Reclamation, Lower Colorado Region, Boulder City, Nev.
- Anderson, B. W., and R. D. Ohmart. 1985. Riparian revegetation as a mitigating process in stream and river restoration. p. 41-80. In J. A. Gore, ed., The restoration of rivers and streams: theories and experience, 280 p. Butterworth Publishers, Boston, Mass.
- Anderson, B. W., and R. D. Ohmart. In press. Evaluation of the impact of vegetation removal. U.S. Bureau of Reclamation, Lower Colorado Region, Boulder City, Nev.
- Anderson, B. W., R. D. Ohmart, and W. C. Hunter. 1983. Quantifying variables for classifying desert riparian vegetation. p. 32-44. In Proceedings of the workshop on southwestern habitat types [Albuquerque, N.M., April 6-8, 1983]. USDA Forest Service, Southwestern Region, Albuquerque, N.M.
- Meents, J. K., J. Rice, B. W. Anderson, and R. D. Ohmart. 1983. Nonlinear relationships between birds and vegetation. *Ecology* 64:1022-1027.
- Rice, J., B. W. Anderson, and R. D. Ohmart. 1984. Comparison of the importance of different habitat attributes of avian community organization. *Journal of Wildlife Management* 48:895-911.
- Rice, J., R. D. Ohmart, and B. W. Anderson. 1983a. Habitat selection attributes of an avian community: a discriminant analysis investigation. *Ecological Monographs* 53:263-290.
- Rice, J., R. D. Ohmart, and B. W. Anderson. 1983b. Turnovers in species composition of avian communities in contiguous riparian habitats. *Ecology* 64:1444-1455.

# Summer Avian Community Composition of Tamarix Habitats in Three Southwestern Desert Riparian Systems<sup>1</sup>

William C. Hunter<sup>2</sup>, Bertin W. Anderson<sup>3</sup>, and

Robert D. Ohmart<sup>4</sup>

---

Abstract.--Data from three southwestern river systems were used to assess avian response to salt cedar (Tamarix chinensis). Species were grouped by breeding biology and groups responded differently in their occurrence in salt cedar among the valleys. Biogeographical and climatic factors may explain these differences.

---

## INTRODUCTION

Rapid expansion of exotic salt cedar (Tamarix chinensis) in the arid Southwest has stimulated research on its life history and its effect on fauna and flora of native riparian habitats (Horton 1964, 1977). Serious concern has developed regarding stability of bird communities occurring in affected riparian systems. Loss of native riparian vegetation and subsequent spread of salt cedar generally has been shown to have negative effects on the population sizes of many riparian bird species (Carothers 1977, Cohan et al. 1978).

Reports on the status of bird populations in riparian vegetation along the lower Colorado River indicate lower species richness and total density of birds in salt cedar compared with most native riparian habitats (Anderson and Ohmart 1984a). At least eight bird species on the lower Colorado River were considered common at the turn of the century (Grinnell 1914) but are now approaching extirpation largely because they remain restricted to dwindling native habitat and do not occur in salt cedar habitats (Hunter 1984). Many of these same species, however, are found in stable numbers in salt cedar habitats along the Rio Grande and the Pecos River (Engel-Wilson and Ohmart 1978, Hildebrandt and Ohmart 1982, Hunter et al. in review). These two river valleys form the eastern boundary of the arid Southwest, while the lower

Colorado River is the last major riparian system on the western boundary.

Data from each of the three river systems were analyzed to assess avian response to salt cedar relative to remaining stands of native habitat on the eastern and western boundaries of the arid Southwest. We are concerned here primarily with bird species of which there is documented evidence of serious declines in population size along the lower Colorado River. We limit our comparisons of habitat use to the summer season (May-July), since many of the species suffering serious declines are breeders on the lower Colorado River. In light of the evidence that some of these declining species use salt cedar in river valleys other than the lower Colorado River, we search for general trends in breeding biology, residency status, and general use of native habitats for all breeding species found in at least two of the three valleys we have studied. We propose that biogeographical and associated climatic factors may be responsible for these trends.

## METHODS

### Description of Vegetation and Study Areas

The lower Colorado River study area extends from Davis Dam on the Arizona-Nevada border to the U.S.-Mexico boundary. Before the middle 1800s, the lower Colorado River was dominated by stands of cottonwoods (Populus fremontii) and willow (Salix gooddingii), with intermittent stands of honey mesquite (Prosopis glandulosa). Screwbean mesquite (P. pubescens) was largely restricted to old backwater areas. Clearing and burning of the native vegetation and water management practices created a void, that was filled by screwbean mesquite and the exotic salt cedar in the early to mid-1900s (Ohmart et al. 1977). Salt cedar is now the numerically dominant riparian tree species along the lower Colorado River covering, in pure stands, 15,688 ha. There remain some large stands of honey mesquite, but these are declining rapid-

---

<sup>1</sup>Paper presented at the Riparian Ecosystems and Their Management: Reconciling Conflicting Uses Conference. [University of Arizona, Tucson, April 16-18, 1985].

<sup>2</sup>William C. Hunter is a Graduate Research Assistant in the Center for Environmental Studies at Arizona State University, Tempe, Ariz.

<sup>3</sup>Bertin W. Anderson is a Research Associate of the Center for Environmental Studies at Arizona State University, Tempe, Ariz.

<sup>4</sup>Robert D. Ohmart is an Associate Director of the Center for Environmental Studies at Arizona State University, Tempe, Ariz.

ly. Pure cottonwood stands, estimated to encompass 2,000 ha in the 1600s, now cover less than 100 ha (Anderson and Ohmart 1984b).

The lower Rio Grande study area extends from Fort Quitman to Presidio, Texas. As on the lower Colorado River, the lower Rio Grande was naturally dominated by cottonwood, willow, and honey mesquite until clearing for agriculture removed almost all of this native vegetation (Engel-Wilson and Ohmart 1978). Presently, only 12 ha of mature cottonwood-willow habitat remain intact. Salt cedar is the dominant phreatophyte on the lower Rio Grande comprising, in a monoculture state, at least 64% (5,600 ha) of the total vegetation (Engel-Wilson and Ohmart 1978).

The middle Pecos River study area extends from Fort Sumner, New Mexico to Pecos, Texas. Historical accounts dating back to the 1600s indicate that the middle Pecos River valley was devoid of mature riparian vegetation except for isolated cottonwood bosques near Roswell and Fort Sumner, New Mexico (Hildebrandt and Ohmart 1982). Honey mesquite is found throughout the valley, but highly structured stands only occur in the southern third of the study area. Presently, salt cedar is the principal riparian tree along the Pecos River, encompassing 22,800 ha in New Mexico, and 87,200 ha in Texas (Pecos River Basin Water Salvage Project 1979).

#### Data Collection

Bird censusing was conducted in all major riparian plant communities following a modified Emlen (1971) variable-distance line transect technique (Anderson and Ohmart 1984). Each of the transects (100 along the Colorado River, 21 along the Rio Grande, and 30 along the Pecos River) was censused three times monthly. Densities were calculated for the summer season (nine censuses for each transect) and expressed as birds/40 ha. Transects were classified into plant community-structure types. Plant communities were identified by the dominant tree species and included cottonwood-willow, honey mesquite, screwbean mesquite (lower Colorado River only), and salt cedar. Structure types were defined by the proportion of total foliage density at each of three vertical layers.

All data were collected by personnel trained by the lower Colorado River field laboratory, which allowed for direct comparison of data among valleys. Data are for four summers from the lower Colorado River (1977-80), one summer from the Rio Grande (1977), and one summer from the Pecos River (1980). Details concerning these and other field techniques employed are presented in Anderson and Ohmart (1984a).

#### Analysis

Bird species were grouped into three main categories based on their peak breeding period. These groups were (1) migratory midsummer breeders, (2) migratory spring and early-summer breeders, and (3) resident spring and early-summer breeders. These criteria were judged by our field

observations and supported by life-history data (Bent 1964, Phillips et al. 1964, Anderson and Ohmart 1984a).

Two lines of analysis were followed after classifying birds into the above categories. The first was to determine the proportion of bird density per unit area in each major plant community among the three river valleys. This was found by equally weighting, by area, each plant community and calculating the percentage of birds that would be found from density estimates. These proportions do not reflect the distribution of individuals among the present distribution of plant communities, but rather they refer to the relative importance of each plant community to bird abundance in each river valley. This allows for direct comparison of the relative importance of salt cedar to bird species in each river valley in relation to available native habitats.

The above approach does not take into account differences in structure type for each community in each river valley. Since there were differences in the amount and kind of structure types found in each valley, a second line of analysis was needed. Due to limitations in space, we present only data for the salt cedar habitats found in each valley. We combined salt cedar transects to stress the average height of the canopy layer in terms of >4.5 m, 0.6-4.5 m, and 0.0-0.6 m. The Rio Grande lacks salt cedar with the peak canopy layer <0.6 m; whereas the Pecos River lacks salt cedar with a canopy height >4.5 m. However, all river valleys have salt cedar with canopy heights between 0.6 and 4.5 m (this is the most often encountered type of salt cedar along other southwestern riparian systems).

Bird densities per month were transformed by taking  $\log_{10} n + 1$  of the density and averaged from transects for salt cedar with 0.0-0.6 m, 0.6-4.5 m, and >4.5 m peak canopy heights both within and among river systems. Duncan's Multiple Range test for variable log of abundance (Zar 1974) was applied to arrange and separate or group salt cedar habitats with an  $\alpha=0.05$  for each bird species. In this way, we could determine the relative importance of average canopy height of salt cedar stands as well as differences among river valleys in the actual densities of birds in salt cedar.

## RESULTS

### Use of Salt Cedar Within Valleys

Seven species occurring in at least two of the studied valleys were determined to be midsummer migratory breeders. All of these species arrive in large numbers no earlier than April with the latest species to arrive, the Yellow-billed Cuckoo (*Coccyzus americanus*), appearing by early June. All of these species are open-cup nesters, and all leave the breeding areas by September. Six of the seven midsummer migratory breeders are found on the Colorado River and five show a clear preference for the cottonwood-willow community on this river system (table 1). Two species, the Western

Table 1.--Proportion of bird populations in plant community types on the lower Colorado River, middle Pecos River, and lower Rio Grande, scaled within valleys. A clear preference for a community is indicated by underlining. A species absence from a river valley is indicated by a dash. CW = Cottonwood-willow; SC = salt cedar; HM = honey mesquite, SM = screwbean mesquite.

Breeding category/species	Time of residency	Proportion of population per unit area									
		Colorado				Pecos			Rio Grande		
		CW	SC	HM	SM	CW	SC	HM	CW	SC	HM
MIDSUMMER MIGRATORY											
Yellow-billed Cuckoo	Jun-Aug	<u>68</u>	2	20	10	53	45	2	54	9	37
Western Kingbird ( <u>Tyrannus verticalis</u> )	Apr-Sep	<u>60</u>	27	6	7	<u>67</u>	18	15	34	0	<u>66</u>
Bell Vireo ( <u>Vireo bellii</u> )	Apr-Sep	<u>67</u>	0	33	0	--	--	--	15	37	48
Yellow-breasted Chat ( <u>Icteria virens</u> )	May-Aug	<u>84</u>	8	2	6	42	58	0	51	35	14
Summer Tanager ( <u>Piranga rubra</u> )	May-Sep	<u>98</u>	2	0	0	<u>87</u>	13	0	28	39	33
Blue Grosbeak ( <u>Guiraca caerulea</u> )	May-Sep	42	30	4	24	41	55	4	43	23	34
Painted Bunting ( <u>Passerina ciris</u> )	May-Sep	--	--	--	--	0	<u>82</u>	18	47	28	25
SPRING AND EARLY SUMMER MIGRATORY											
Ash-throated Flycatcher ( <u>Myiarchus cinerascens</u> )	Mar-Oct	21	13	35	31	<u>72</u>	11	17	10	44	46
Lucy Warbler ( <u>Vermivora luciae</u> )	Mar-Jul	15	27	33	25	--	--	--	11	49	40
Brown-headed Cowbird ( <u>Molothrus ater</u> )	Mar-Jul	33	26	14	27	22	<u>65</u>	13	<u>55</u>	28	17
Northern Oriole ( <u>Icterus galbula</u> )	Mar-Jul	47	12	22	19	<u>71</u>	26	3	40	20	40
SPRING AND EARLY SUMMER RESIDENTS											
Greater Roadrunner ( <u>Geococcyx californianus</u> )	Permanent	17	26	30	27	8	<u>75</u>	17	16	12	<u>72</u>
Ladder-backed Woodpecker ( <u>Picoides scalaris</u> )	Permanent	47	7	20	26	<u>80</u>	13	7	46	31	23
Verdin ( <u>Auriparus flaviceps</u> )	Permanent	23	14	31	32	0	0	<u>100</u>	4	9	<u>87</u>
Cactus Wren ( <u>Campylorhynchus brunneicapillus</u> )	Permanent	26	6	<u>58</u>	10	0	0	<u>100</u>	0	0	<u>100</u>
Black-tailed Gnatcatcher ( <u>Polioptila melanura</u> )	Permanent	10	16	39	35	--	--	--	0	5	<u>95</u>
Northern Mockingbird ( <u>Mimus polyglottos</u> )	Permanent	<u>52</u>	13	22	13	56	34	10	20	16	<u>64</u>
Crissal Thrasher ( <u>Toxostoma crissale</u> )	Permanent	19	18	<u>44</u>	19	7	<u>64</u>	29	0	13	<u>87</u>
Pyrrhuloxia ( <u>Cardinalis sinuatus</u> )	Permanent	--	--	--	--	0	18	<u>82</u>	0	0	<u>100</u>

Kingbird and Blue Grosbeak occur in the salt cedar community to some extent, but the other species are largely absent from salt cedar. In contrast, these same species on the Rio Grande and Pecos River occur in greater proportions in salt cedar compared with native plant communities, with the exception of the Western Kingbird. Only two of six species show clear preferences for cottonwood-willow on the Pecos River. The migratory midsummer breeding species are not as restricted to the cottonwood-willow community on the Pecos River and Rio Grande as they are on the Colorado River.

Four species were classified as migratory spring and early summer breeders. These species arrive by late March and all but the Ash-throated Flycatcher leave the breeding areas by July. The Brown-headed Cowbird is a nest parasite and does not build its own nest. The other three species have protective nests placed in tree cavities or constructed to conceal the eggs. No clear preference patterns exist in any plant community for any river valley in this category (table 1). The salt cedar community is not avoided in any of the river valleys by any of these species.

Eight species were classified as resident spring and early summer breeders. At least four species begin breeding activities by mid-February. Many of these species produce multiple broods with the last young fledging by July. Five of the eight species build open-cup nests, two build covered nests, and one uses cavities for nesting. Seven of eight species are restricted to the honey mesquite community on the Rio Grande, with only the Ladder-backed Woodpecker showing higher proportional occurrence in the cottonwood-willow community (table 1). The Ladder-backed Woodpecker is the only species in this category to occur consistently in higher proportions in the cottonwood-willow community in each river valley. This probably relates to easier excavation of cavities in cottonwoods and willows, compared with honey mesquite and salt cedar. The Greater Roadrunner and Crissal Thrasher show very high proportional use of salt cedar on the Pecos River in contrast to their use of this plant community on the Rio Grande and Colorado River. The Verdin, Cactus Wren, and Black-tailed Gnatcatcher show stronger restriction to honey mesquite on the Rio Grande and/or Pecos River, on the Southwest's eastern riparian systems, than they do on the Colorado River, which represents the most western riparian system.

#### Use of Salt Cedar Among Valleys

Proportion of bird densities per unit area in each plant community reported above does not take into account differences in structure types found on each river system. Below we present results and trends found in bird occurrence in salt cedar in relation to the average canopy height layer in each river valley.

We report first on the average canopy layer between 0.6-4.5 m since it was found in each river valley. Four migratory midsummer breeding insectivores have significantly higher densities in salt cedar on the Rio Grande with an additional three

species on the Pecos River at this canopy height ( $P < 0.05$ , table 2). Two species in this breeding category, Blue Grosbeak and Western Kingbird, occurred in as high or higher density on the Colorado River than found on the Pecos River and the Rio Grande, respectively. Three of four migratory spring and early-summer breeders were found to have significantly higher densities on the Colorado River; only the Brown-headed Cowbird was not found to differ in density among the three river valleys. Four of seven resident spring and early-summer breeders occurring on the lower Colorado River were found in significantly higher densities there. Greater Roadrunner and Ladder-backed Woodpecker densities were high on the Colorado but were not different from the Pecos River and Rio Grande, respectively. For both the second and third breeding categories, only Northern Mockingbird occurred in significantly lower densities on the Colorado River than found in the other two river systems. In summary, five of six species of migratory mid-summer breeders have significantly lower densities on the Colorado River when compared with the Rio Grande and/or Pecos River; whereas, nine of 11 spring and early-summer breeding species occurring on the Colorado River were found in significantly lower densities on the Rio Grande and/or Pecos River.

In salt cedar with average canopy heights  $>4.5$  m, four of seven migratory midsummer breeding species have significantly higher densities on the Rio Grande than on the Colorado River. Two species, Western Kingbird and Blue Grosbeak, have significantly higher densities on the Colorado River. Only one of 11 spring and early-summer breeders (including both migratory and resident) on the Colorado River was found in significantly lower densities than on the Rio Grande.

Salt cedar with average canopy height 0.0-0.6 m has three of five migratory midsummer breeders, mutually occurring on both the Pecos and Colorado rivers, with significantly higher densities on the Pecos River. All migratory midsummer breeders have lower densities on the Colorado River. The Northern Mockingbird was, as at the other two canopy heights, the only spring and early-summer breeder to be found in significantly lower densities on the Colorado River.

## DISCUSSION

### Comparing Salt Cedar Use Among Valleys

No species was found to use salt cedar among valleys consistently, in relation to structure type or in use of native plant communities. The Ladder-backed Woodpecker, Blue Grosbeak, and Brown-headed Cowbird were species in which reasonable predictions could be made on use of salt cedar in all river systems from knowledge of only one river system. Therefore, applying data from one river system for use of salt cedar will lead to serious errors in management on other river systems for most riparian bird species.

Data on Bell Vireos can be used as a possible source for such errors. The Bell Vireo on the

Table 2.--Relative use of salt cedar at three levels of canopy height by birds on the lower Colorado River (CR), lower Rio Grande (RG), and middle Pecos River (PR). Bird densities transformed to  $\log_{10} n+1/40$  ha. Significant values are derived from Duncan's Multiple Range Test for variable logs of abundance (Ott 1977),  $\alpha = 0.05$ . A species absence from a river valley is indicated by a dash.

Breeding category/ species	Bird density in canopy layer height levels						
	0.6-4.5 m			>4.5 m		0.0-0.6 m	
	CR	RG	PR	CR	RG	CR	PR
MIDSUMMER MIGRATORY							
Yellow-billed Cuckoo	0.000	0.301	0.975 <sup>a</sup>	0.000	0.301 <sup>a</sup>	0.000	0.418 <sup>a</sup>
Western Kingbird	0.560	0.000	0.877 <sup>a</sup>	0.861 <sup>a</sup>	0.000	0.360	1.133 <sup>a</sup>
Bell Vireo	0.000	1.148 <sup>a</sup>	-	0.000	0.736 <sup>a</sup>	0.000	-
Yellow-breasted Chat	0.634	1.860 <sup>a</sup>	0.911 <sup>b</sup>	0.301	1.743 <sup>a</sup>	0.000	0.000
Summer Tanager	0.000	1.108 <sup>a</sup>	0.301	0.810	1.450 <sup>a</sup>	0.000	0.259
Blue Grosbeak	1.260 <sup>a</sup>	1.048	1.377 <sup>a</sup>	1.026 <sup>a</sup>	0.715	0.901	1.085
Painted Bunting	-	1.233 <sup>a</sup>	0.783	-	1.038	-	0.000
SPRING AND EARLY SUMMER MIGRATORY							
Ash-throated Flycatcher	0.810 <sup>a</sup>	0.602	0.360	0.885 <sup>a</sup>	0.259	0.699 <sup>a</sup>	0.418
Lucy Warbler	1.457 <sup>a</sup>	0.983	-	1.967 <sup>a</sup>	0.703	1.002	-
Northern Oriole	1.203 <sup>a</sup>	0.301	0.641 <sup>b</sup>	1.012 <sup>a</sup>	0.301	0.661	0.761
Brown-headed Cowbird	1.513	1.437	1.373	1.363	1.397	1.227	1.170
SPRING AND EARLY SUMMER RESIDENT							
Greater Roadrunner	0.634 <sup>a</sup>	0.100	0.774 <sup>a</sup>	0.502 <sup>a</sup>	0.100	0.519	0.735
Ladder-backed Woodpecker	0.634 <sup>a</sup>	0.593 <sup>a</sup>	0.301	0.593 <sup>a</sup>	0.201	0.360	0.201
Verdin	0.950 <sup>a</sup>	0.534 <sup>b</sup>	0.000	1.171 <sup>a</sup>	0.000	0.952 <sup>a</sup>	0.000
Cactus Wren	0.492 <sup>a</sup>	0.000	0.000	0.301 <sup>a</sup>	0.000	0.418 <sup>a</sup>	0.000
Black-tailed Gnatcatcher	0.816 <sup>a</sup>	0.359	-	0.725 <sup>a</sup>	0.000	0.842	-
Crissal Thrasher	0.752 <sup>a</sup>	0.233	0.579 <sup>b</sup>	0.560 <sup>a</sup>	0.100	0.678	0.667
Northern Mockingbird	0.201	0.560 <sup>b</sup>	1.533 <sup>a</sup>	0.201	0.761 <sup>a</sup>	0.301	1.390 <sup>a</sup>
Pyrhuloxia	-	0.301	0.259	-	0.159	-	0.301

<sup>a</sup>Denotes significantly higher abundance compared with same canopy height level in other river valleys.

<sup>b</sup>Abundance significantly lower than <sup>a</sup> but significantly higher than the remaining river valley.

lower Colorado River is nearly extirpated as a breeding species; although, at the turn of the century it was listed by Grinnell (1914) as among the most characteristic birds in the willow-cottonwood association. This species fails to use pure salt cedar stands on the lower Colorado River but still occurs and breeds rarely in salt cedar mixed with honey mesquite as well as remaining cottonwood-willow stands. On the Rio Grande, this species occurs in high densities and uses pure salt cedar. Therefore, it has remained common in this river valley. In addition, Bell Vireos are spreading in the Grand Canyon coincidental to the spread of salt cedar along the Colorado River

(Brown et al. 1983); however, salt cedar in this area forms a narrow band adjacent to the mesquite belt which is similar to salt cedar-honey mesquite mix habitats where we find Bell Vireos on the lower portion of the river. If we wanted to manage for Bell Vireos on the lower Colorado River based on Rio Grande or Grand Canyon data, we would show that salt cedar is acceptable to this species and might recommend that salt cedar not be cleared, in fact, we might encourage its proliferation. Given the present Bell Vireo density in pure salt cedar habitats on the lower Colorado River (0/40 ha), this would be a serious mistake. The same can be said for Summer Tanagers based on Rio



Grande data and Yellow-billed Cuckoos from Pecos River data. All three of these species are in serious danger of extirpation from the lower Colorado River.

Colorado River data alone would indicate that the majority of birds do not use salt cedar in high proportions compared with native plant communities. Thus, we might recommend that clearing salt cedar from other river valleys would not seriously impact riparian bird populations. However, for many species on the Rio Grande and Pecos River, there would be serious impacts if native plant communities were not restored where salt cedar was to be cleared. The important point here is that each river valley should be surveyed for the range of riparian habitats available and how each bird species responds to each habitat; relying on data from geographically distant river systems or even different portions of the same river system are unacceptable options.

#### Biogeographical Considerations

Few patterns in bird occurrence in salt cedar exist if the three river systems are considered separately. Two patterns that do exist are (1) migratory midsummer breeding species are largely restricted to cottonwood-willow and avoid salt cedar on the Colorado River and (2) resident spring and early-summer residents are restricted to honey mesquite and avoid salt cedar on the Rio Grande. Since the Pecos River is a major tributary to the Rio Grande and these rivers together form the easternmost riparian zones in the arid Southwest, we contrast data from these two rivers with data from the lower Colorado River. Several additional patterns emerge representing the entire arid Southwest by comparing eastern and western boundaries.

Species that are migratory midsummer breeders on the lower Colorado River may be associated with mature broadleaf riparian forests because they cannot tolerate lower-statured salt cedar or other riparian habitats (i.e., honey mesquite and open stands of cottonwood-willow) that do not provide a multilayered foliage cover to protect these species (and/or their eggs and young) from thermal stress. In fact, all bird species that occur extensively in salt cedar on the lower Colorado River during summer (beside doves; see Walsberg and Voss-Roberts 1983) begin nesting early in the year (March through June) and/or have covered nests. Elevational gradient lowers from east to west, and in the arid Southwest average summer temperatures become higher so that the lower Colorado River represents the extreme summer environment.

Migratory and resident spring and early-summer breeding species show a trend of declining use of salt cedar from west to east. Many of these species occur in salt cedar and other plant communities on the lower Colorado River but become rare and restricted to honey mesquite on the Rio Grande and Pecos River. These species are primarily Sonoran and Chihuahuan desert species. Cold winters in western Texas and eastern New Mexico

may not allow the permanent resident species to spread into alternative riparian habitats such as salt cedar and survive to breed the next year. As one proceeds from west to east winters become more severe, but where winters are less severe (as on the Colorado River) and, at least during some years, when food resources remain high, individuals forced into "suboptimal" habitats may survive to breed the next year (Anderson et al. 1982).

These data suggest that environmental extremes, such as seasonal temperature, may be important in a species' ability to use all available habitats. We are observing groups of species with similar habitat preferences and with similar breeding biology becoming restricted in the same way in their use of habitats. The response to salt cedar may be linked to the abilities of these species to cope with extreme physiological conditions and not only to the presence or absence of interspecific competition for limited nesting space or food resources (Carothers et al. 1974). Data on relative insulation properties of salt cedar, insect biomass, and relative bird use of salt cedar along an east-west gradient are needed to help clarify these points. The Gila River, in Arizona, presently is under study to investigate further the trends presented here.

#### ACKNOWLEDGMENTS

Dr. J. Rice was instrumental in assisting with data analysis and interpretation. Field work was accomplished by many dedicated biologists to whom we are grateful. We thank J. R. Durham and C. D. Zisner for editing assistance. C. D. Zisner also typed the manuscript. The research was funded by the U.S. Bureau of Reclamation Contracts No. 9-07-57-V0567 and 7-07-30-V0009 and the International Boundary and Water Commission Contract No. IBWC IBM77-17.

#### LITERATURE CITED

- Anderson, B. W., and R. D. Ohmart. 1984a. Vegetation management study for the enhancement of wildlife along the lower Colorado River. Comprehensive Final Report to U.S. Bureau of Reclamation, Boulder City, Nev. 529 p.
- Anderson, B. W., and R. D. Ohmart. 1984b. Vegetation type maps of the lower Colorado River from Davis Dam to the southerly international boundary, update 1982. Bureau of Reclamation, Lower Colorado Region, Boulder City, Nev.
- Anderson, B. W., R. D. Ohmart, and S. D. Fretwell. 1982. Evidence of social regulations in some riparian bird populations. *American Naturalist* 120:340-352.
- Bent, A. C. 1964. *Life histories of North American birds*. Dover Publications, Inc., New York, N.Y.
- Brown, B. T., S. W. Carothers, and R. R. Johnson. 1983. Breeding range expansion of Bell's Vireos in Grand Canyon, Arizona. *Condor* 85:499-500.

- Carothers, S. W. 1977. Importance, preservation and management of riparian habitat: an overview. p. 2-4. In Importance, preservation and management of riparian habitat: a symposium. [Tucson, Ariz., July 9, 1977] USDA Forest Service General Technical Report RM-43, 217 p. Rocky Mountain Forest and Range Experiment Station, Fort Collins, Colo.
- Carothers, S. W., R. R. Johnson, and S. W. Aitchison. 1974. Population structure and social organization of southwestern riparian birds. *American Zoologist* 14:97-108.
- Cohan, D. R., B. W. Anderson, and R. D. Ohmart. 1978. Avian population responses to salt cedar along the lower Colorado River. p. 371-382. In Strategies for protection and management of floodplain wetlands and other riparian ecosystems. [Callaway Gardens, Ga., December 11-13, 1978] USDA Forest Service General Technical Report WO-12, 410 p. USDA Forest Service, Washington, D.C.
- Emlen, J. T. 1971. Population densities of birds derived from transect counts. *Auk* 88:323-342.
- Engel-Wilson, R. W., and R. D. Ohmart. 1978. Floral and attendant faunal changes on the lower Rio Grande between Fort Quitman and Presidio, Texas. p. 139-147. In Strategies for protection and management of floodplain wetlands and other riparian ecosystems. [Callaway Gardens, Ga., December 11-13, 1978] USDA Forest Service General Technical Report WO-12, 410 p. USDA Forest Service, Washington, D.C.
- Grinnell, J. 1914. An account of the mammals and birds of the lower Colorado River valley with especial reference to the distributional problems presented. University of California Publications in Zoology 12:51-294.
- Hildebrandt, T. D., and R. D. Ohmart. 1982. Biological resource inventory (vegetation and wildlife) -- Pecos River Basin, New Mexico and Texas. Final Report to U.S. Bureau of Reclamation, 160 p. + 24 maps. Amarillo, Tex.
- Horton, J. S. 1964. Notes on the introduction of deciduous-tamarisk. USDA Forest Service Research Note RM-16, 7 p. Rocky Mountain Forest and Range Experiment Station, Fort Collins, Colo.
- Horton, J. S. 1977. The development and perpetuation of the permanent tamarisk type in the phreatophyte zone of the Southwest. p. 124-127. In Importance, preservation and management of riparian habitat: a symposium. [Tucson, Ariz., July 9, 1977] USDA Forest Service General Technical Report RM-43, 217 p. Rocky Mountain Forest and Range Experiment Station, Fort Collins, Colo.
- Hunter, W. C. 1984. Status of nine bird species of special concern along the Colorado River. Wildlife Management Administrative Report No. 84-A, California Department of Fish and Game, Nongame Wildlife Investigations, Sacramento, Calif.
- Ohmart, R. D., W. O. Deason, and C. Burke. 1977. A riparian case history: the Colorado River. p. 35-46. In Importance, preservation and management of riparian habitat: a symposium. [Tucson, Ariz., July 9, 1977] USDA Forest Service General Technical Report RM-43, 217 p. Rocky Mountain Forest and Range Experiment Station, Fort Collins, Colo.
- Pecos River Basin Water Salvage Project. 1979. Final environmental statement. U.S. Bureau of Reclamation Regional Office, Southwest Region, Amarillo, Tex.
- Phillips, A. R., J. Marshall, and G. Monson. 1964. The birds of Arizona. 212 p. University of Arizona Press, Tucson, Ariz.
- Walsberg, G., and K. A. Voss-Roberts. 1983. Incubation in desert-nesting doves: mechanisms for egg cooling. *Physiological Zoology* 56:88-93.
- Zar, J. H. 1974. Biostatistical analysis. Prentice-Hall, Englewood Cliffs, N.J. 620 p.

# Revegetating Riparian Trees in Southwestern Floodplains<sup>1</sup>

Edwin A. Swenson<sup>2</sup>

Charles L. Mullins<sup>3</sup>

---

Abstract.--Riparian areas continue to be drastically altered, usually by man's activities. Managers have generally been unsuccessful in using conventional techniques to replace riparian trees. Our experiments with Rio Grande cottonwood, narrowleaf cottonwood, and Gooding willow have shown that a simple and inexpensive method for their reestablishment is now available.

---

## INTRODUCTION

Riparian trees of the Southwest are important to wildlife, as studies have shown (Carothers et al., 1974, Freehling 1982, Hink and Ohmart 1984, Hubbard 1977, and Stamp 1978). Many major Southwest floodplains, however, no longer support viable riparian stands. Agricultural drainage, channelization, flood control, livestock, irrigation diversions, and control of phreatophytes have taken a heavy toll (Carothers 1977, Engel-Wilson and Ohmart 1979, Graf 1980, Johnson 1970, Johnson and Carothers 1975, and Platts 1979).

Older relict stands are dying and little natural reproduction is occurring because of dry surface soils, low precipitation, grazing pressure, and drastic reductions in flooding (Anderson and Ohmart 1976, Engel-Wilson and Ohmart 1979, and Glinski 1977). Managers of these riparian ecosystems have generally been unsuccessful in using conventional techniques to replace trees: site conditions are too dry for the use of rooted seedlings, and irrigation is too costly. New technologies are being developed to reclaim degraded or destroyed riparian woodland (Anderson and Ohmart 1976, Anderson et al., 1978). Tree establishment, however, has been hampered by lowered groundwater

levels, elimination of flooding, low precipitation, grazing, and invasion by saltcedar (Tamarix chinensis) (Anderson et al., 1977, Campbell and Dick-Peddie 1964, Horton 1972, and McKinney 1981).

From 1981 to 1983, we studied the feasibility of using Rio Grande cottonwood (Populus fremontii), narrowleaf cottonwood (P. angustifolia), and Gooding willow (Salix nigra var. vallicola) to restore riparian stands. Our method was to place large pole cuttings in holes drilled to deep water tables or in lysimeters. Our objectives were: (1) to determine if tree cuttings would become established where groundwater was 7 to 12 feet below ground surface, (2) to determine if survival was related to time of taking and setting the cuttings, and (3) using lysimeters to establish relationships between tree survival and the depth of cutting placement above constant water tables.

## STUDY AREA AND METHODS

Study plots were established within the historic floodplain of the Rio Grande at locations south of Albuquerque, New Mexico. Groundwater was monitored by observation wells during the period of the study. Some study plots were placed where water fluctuated naturally; others were located in lysimeters where water tables were stabilized mechanically.

The soils are deep sandy loams; some have narrow clay lenses scattered throughout the profile. Groundwater contains 700 to 900 ppm of dissolved solids and is considered suitable for crop irrigation. Annual precipitation averaged slightly under 6 inches during the 3 years of the study.

---

<sup>1</sup>Paper presented at the Interagency North American Riparian Conference, Riparian Ecosystems and Their Management: Reconciling Conflicting Uses, Tucson, Arizona, April 16-18, 1985.

<sup>2</sup>Edwin A. Swenson is the State Biologist, U.S.D.A., Soil Conservation Service, Albuquerque, N.M.

<sup>3</sup>Charles L. Mullins is a Fish and Wildlife Biologist, U.S.D.I., Fish and Wildlife Service, Albuquerque, N.M.

solids and is considered suitable for crop irrigation. Annual precipitation averaged slightly under 6 inches during the 3 years of the study.

Poles were cut from individual saplings growing locally within leveed river sections where controlled flooding had provided for natural reproduction. Saplings with a basal diameter of 2 to 3 inches and a height of up to 20 feet were used. All side branches were removed and the top was cut back to a 3/8-inch diameter.

Among all the plots, groundwater depth ranged from 7 to 12 feet. Groups of cuttings (5 to 50 each) were placed in drilled holes so that the butts were: (1) at groundwater depth, (2) 2 feet above, and (3) 4 feet above groundwater. All cuttings were sized so that 4 to 6 feet of the cutting was above ground. All holes were backfilled to the surface. To stimulate top growth, buds on the lower half of the cutting were wiped off when they first appeared in the spring (usually April). Because our goal was a simple, inexpensive planting technique with wide applicability, we did not use rooting hormones or sealants on the cut surfaces.

Plots were divided so that each replication had equal numbers of dormant poles (cut and planted in December or January) and greenwood poles (cut and planted in March after bud development had started).

## RESULTS

Our results indicate that cottonwood and willow poles can successfully be used to revegetate floodplains with deep (7 to 12 feet) water tables during the period of active plant growth. In general, large cuttings (13 to 20 feet long) of all three native tree species became established. Vertical growth averaged 30 inches each year.

For dormant poles set with the butts at constant water tables of 7, 8, 8, and 12 feet, survival rates were 60, 90, 100, and 77 percent, respectively. Survival was lower for dormant poles placed 2 and 4 feet above the water table. It was also lower for greenwood cuttings (table 1).

Poles in plots with naturally fluctuating water tables had lower rates of survival than those in plots with constant water tables (table 2). Fluctuating water tables dropped as much as 20 inches from April to September, the period of active growth. Relationships of survival to depth of cutting placement and to time of taking the cuttings were similar to those in the constant water table plots (table 2).

We found little difference in survival or growth rates by species. Not all cuttings produced the desired top growth; however, some produced ground level growth, which is undesirable because it would be accessible to livestock.

A number of study plot locations failed to grow living trees for reasons worth describing. Flooding for periods longer than 3 weeks killed all established poles. Beaver cut living poles at ground line and the subsequent low sprouting was browsed by livestock. Cattle are able to walk down substantial sized poles, breaking them off at ground level. Plantings made in the Pecos River Valley of eastern New Mexico were consistent failures, possibly because of high ground-water salinity (up to 4,000 ppm).

Poles exhibited no obvious insect problems and only slight girdling damage from rodents or lagomorphs. On the few plots where girdling was a problem, we installed a plastic netting cylinder around each cutting.

## MANAGEMENT IMPLICATIONS

Placing large dormant cuttings into holes predrilled to known depth of the growing season water table can be a simple and inexpensive method of revegetating floodplains. The manager must determine, however, that prolonged flooding will not occur at the site and that beaver and livestock can be controlled.

Excavation of root systems indicated that placing the poles into the water table will produce better results where the water table is higher during the winter planting season (December, January) than during the growing season. Therefore, it is essential that water table depth be monitored at proposed planting sites. We recommend establishing observation wells at proposed sites for at least one growing season prior to planting. This monitoring allows better selection of a planting depth for improved establishment.

Use of dormant cuttings is recommended. The suitable time for taking them is almost 90 days, from November to February. By contrast, the optimal period for taking greenwood cuttings is 15 to 20 days and their survival is lower. Planting the cuttings at anticipated growing season water table depth rather than above it will enable the poles to have the best chance of success.

Restocking of depleted riparian areas is not a permanent solution, however. Without periodic flooding, on a frequency of once every 20 to 40 years or so, adequate natural reseeding will not occur.

Table 1.--Survival of Cuttings at Constant Groundwater Levels

Type of Cutting	Method of Controlling or Monitoring Water Table	Planting Date	Date of Measurement	Survival by Depth (ft.) of Cutting Placement								
				Water Table 7.3 ft.			Water Table 8.3 ft.			Water Table 11 ft.		
				7 ft.	5 ft.	3 ft.	8 ft.	6 ft.	4 ft.	11.5 ft.		
				-----Percent-----								
Dormant	Lysimeter <sup>2</sup>	12/80	9/81	70	80	0	100	80	60	---		
			9/82	60	50	0	100	50	40	---		
			9/83	60	50	0	90	50	30	---		
Dormant	Lysimeter	12/81	9/82	--	--	--	100	40	30	---		
			9/83	--	--	--	100	40	30	---		
Dormant	Well <sup>4</sup>	1/83	9/83	--	--	--	--	--	--	77		
Greenwood	Lysimeter	3/82	9/81	100	70	0	100	50	60	---		
			9/82	40	50	0	100	20	20	---		
			9/83	40	50	0	100	20	10	---		
Greenwood	Lysimeter	3/82	9/82	--	--	--	90	50	0	---		
			9/83	--	--	--	90	50	0	---		

<sup>1</sup>Depth of planted cuttings.

<sup>2</sup>Ten cuttings placed within each lysimeter; water table artificially controlled at 7.3 ft. or 8.3 ft.

<sup>3</sup>Dashes mean no cuttings placed at the given depth.

<sup>4</sup>Water table level monitored by observation well; 20 cuttings placed in each area monitored by a well. Depth to constant water table averaged 11 ft.

Table 2.--Survival of Cuttings at Fluctuating Groundwater Levels

Type of Cutting	Plot Number <sup>1</sup>	Planting Date	Date of Measurement	Survival by Depth (ft.) of Cutting Placement								
				Water Table 7.5 ft. - 9.2 ft.			Water Table 7.0 ft. - 9.4 ft.					
				7 ft.	5 ft.	3 ft.	8 ft.	6 ft.	4 ft.			
				-----Percent-----								
Dormant	2	12/80	9/81	84	24	0	---	---	---	---		
			9/82	65	20	0	---	---	---	---		
			9/83	28	15	0	---	---	---	---		
Dormant	3	12/81	9/82	--	--	--	80	60	35			
			9/83	--	--	--	73	50	30			
Greenwood	2	3/81	9/81	56	24	0	--	--	--			
			9/82	55	20	0	--	--	--			
			9/83	30	10	0	--	--	--			
Greenwood	3	3/82	9/82	--	--	--	60	55	5			
			9/83	--	--	--	60	40	5			

<sup>1</sup>Plot 2 had five replications, five poles per treatment (dormant and greenwood), and a fluctuating water table at depths of 7.5 ft. to 9.2 ft. Plot 3 had three replications, ten poles per treatment, and a fluctuating water table at depths of 7.0 ft. to 9.4 ft.

<sup>2</sup>Depth of planted cuttings.

<sup>3</sup>Dashes mean no poles were placed at the given depth.

We believe that cottonwoods and willows can be successfully established in small openings within existing stands of saltcedar. Further study is needed, but our observation of natural stands suggest that these trees will overtop and shade out the saltcedar.

#### LITERATURE CITED

- Anderson, B. W., A. Higgins, and R. D. Ohmart. 1977. Avian use of saltcedar communities in the Lower Colorado River Valley. Pages 128-136. *In* Importance, Preservation, and Management of Riparian Habitat: A Symposium. U.S. Dept. of Agriculture, Forest Service, Tucson, Arizona. 217 pp.
- Anderson, B. W. and R. D. Ohmart. 1976. A vegetation management study for the enhancement of wildlife along the Lower Colorado River. Contract No. 7-07-30-V0009. Bureau of Reclamation. Lower Colorado Region. 190 pp. plus appendices.
- Anderson, B. W., R. D. Ohmart, and J. Disano. 1978. Revegetating the riparian floodplain for wildlife. Pages 318-331. *In* Strategies for Protection and Management of Floodplain Wetlands and Other Riparian Ecosystems. U.S. Dept. of Agriculture, Forest Service, Calloway Gardens, Georgia. 410 pp.
- Campbell, C. J. and W. A. Dick-Peddie. 1964. Comparison of phreatophyte communities on the Rio Grande in New Mexico. *Ecology* 45:492-502.
- Carothers, S. W. 1977. Importance, preservation, and management of riparian habitats: an overview. Pages 2-4. *In* Importance, Preservation, and Management of Riparian Habitat: A Symposium. R. R. Johnson and D. A. Jones (tech. coord.). U.S. Forest Service General Technical Report RM-43, Rocky Mt. Forest and Range Exp. Sta., Fort Collins, Colorado.
- Carothers, S. W., R. R. Johnson, and S. W. Aitchison. 1974. Population structure and social organization of southwestern riparian birds. *Amer. Zool.* 14:97-108.
- Engel-Wilson, R. W. and R. D. Ohmart. 1979. Floral and attendant faunal changes on the Lower Rio Grande between Fort Quitman and Presidio, Texas. *In* Strategies for Protection and Management of Floodplain Wetlands and Other Riparian Ecosystems. R. R. Johnson and J. E. McCormick (tech coord.). U.S. Forest Service General Technical Report WO-12, Washington, D.C. Pages 139-147.
- Freehling, M. D. 1982. Riparian woodlands of the Middle Rio Grande Valley, New Mexico: a study of bird populations and vegetation. U.S. Fish and Wildlife Service, Office of Environment, Albuquerque, New Mexico. 35 pp.
- Glinski, R. L. 1977. Regeneration and distribution of sycamore and cottonwood trees along Sonoita Creek, Santa Cruz County, Arizona. Pages 123-166. *In* Importance, Preservation, and Management of Riparian Habitat: A Symposium. R. R. Johnson and D. A. Jones (tech. coord.). U.S. Forest Service General Technical Report RM-43, Rocky Mt. Forest and Range Exp. Sta., Fort Collins, Colorado.
- Graf, W. L. 1980. Riparian management: a flood control perspective. *J. of Soil and Water Conservation.* 35:158-161.
- Hink, V. C. and R. D. Ohmart. 1984. Middle Rio Grande biological survey. Contract No. DACW47-81-C-0015. Corps of Engineers, Albuquerque District. 112 pp. plus appendices.
- Horton, J. S. 1972. Management problems in phreatophyte and riparian zones. *J. of Soil and Water Conservation.* 27:57-61.
- Hubbard, J. P. 1977. Importance of riparian ecosystems: biotic considerations. Pages 14-18. *In* Importance, Preservation, and Management of Riparian Habitat: A Symposium. U.S. Dept. of Agriculture, Forest Service, Tucson, Arizona. 217 pp.
- Johnson, R. R. 1970. Tree removal along southwestern rivers and effects on associated organisms. *Amer. Phil. Soc. Yearbook.* 1970. Pages 321-322.
- Johnson, R. R. and S. W. Carothers. 1975. The effects of stream channel modifications of birds in the southwestern United States. *Symposium on Stream Channel Modification Proceedings.* Harrisburg, Virginia.
- McKinney, M. 1981. Learning to manage southwestern riparian ecosystems. *In* Forest Research West, U.S. Forest Service.
- Platts, W. S. 1979. Livestock grazing and riparian/stream ecosystems: an overview. Pages 39-45. *In* Forum-Grazing and Riparian/Stream Ecosystems. Trout Unlimited, Denver, Colorado. 94 pp.
- Stamp, N. E. 1978. Breeding birds of riparian woodlands in southcentral Arizona. *Condor* 80:64-71.

# Limits on Regeneration Processes in Southeastern Riverine Wetlands<sup>1</sup>

R. R. Sharitz and L. C. Lee<sup>2</sup>

---

Abstract.--Principal factors that affect seedling recruitment in mature cypress-tupelo forests include seed production, microsite availability and hydrologic regime. Studies on the Savannah River floodplain in South Carolina show that although seed production seems adequate, microsite characteristics and water level changes limit regeneration success. Management of water levels on regulated streams must account for species regeneration requirements to maintain floodplain wetland community structure.

---

## INTRODUCTION

Development and maintenance of forested wetlands is dependent, in part, upon the ability of species to replace themselves or of other species to replace them. Both vegetative and sexual means of reproduction may be significant in determining the species composition and structure of wetland stands. In highly disturbed wetlands, sprouts from the stumps or root systems of damaged individuals may be the chief means of forest recovery (Fonda 1974; Hawk and Zoebel 1974; Gardner 1980; Lee 1983). In natural forested wetland communities, reproduction by seed, especially in canopy gaps, often plays a major role in species regeneration and the long term maintenance of stand composition (Whittaker and Levin 1977). Species establishment processes in wetland ecosystems are important for several reasons. It has been shown that patterns and rates of elemental cycling through wetlands change with successional development (Sloey et al. 1978; Klopatek 1978). The net primary productivity of wetland sites and associated stream ecosystems can vary significantly, depending largely upon the species composition and condition of wetland plant communities (Palmisano 1978; Minshall et al. 1983).

The value of wetlands to fish and wildlife species can often be directly linked to the structure imparted to wetland habitats by the existing vegetation (Williams and Dodd 1978; Thomas et al. 1979).

Dominant plant species in floodplain forests typically are distributed along environmental gradients that can be associated with topographic and hydrologic factors (Robertson et al. 1978; Wharton et al. 1982; Van Cleve et al. 1980). Along many of the major river systems in the southeastern coastal plain, bald cypress (*Taxodium distichum*<sup>3</sup>) and water tupelo (*Nyssa aquatica*), occur as canopy codominants in areas that are inundated on a nearly permanent basis (Larsen et al. 1981; Wharton et al. 1982). Transition areas from these extensively flooded sites to adjacent uplands are characterized by a shift in canopy dominance from cypress and tupelo to species such as red maple (*Acer rubrum*), oaks (e.g. *Quercus laurifolia*, *Q. nigra*, *Q. lyrata*), sweetgum (*Liquidambar styraciflua*) and other bottomland hardwoods that are tolerant of poorly drained soil conditions (Fowells 1965; Teskey and Hinckley 1977; Hook 1984). In southern floodplain forests minor shifts in edaphic and hydrologic features usually result in mosaic patterns of species distributions and wetland community types (Robertson et al. 1978).

---

<sup>1</sup>Paper presented at the first North American riparian conference, "Riparian Ecosystems and Their Management: Reconciling Conflicting Uses." [Tucson, AZ, April 16-18, 1985].

<sup>2</sup>Rebecca R. Sharitz and Lyndon C. Lee are Division Head and Research Manager, respectively, of the Division of Wetland Ecology, University of Georgia Savannah River Ecology Laboratory, Aiken, SC. Research conducted under contract DE-AC0976SR00819 between the U.S. Dept. of Energy and the University of Georgia.

Many wetland forest species have specific environmental requirements for seed germination and seedling establishment (Schopmeyer 1974; Teskey and Hinckley 1977). For example, seeds of both bald cypress and water tupelo require a moist, yet non-flooded substrate to germinate

---

<sup>3</sup>All taxonomic nomenclature follows Radford et al. (1968).

(Schopmeyer 1974). Furthermore, field and laboratory studies have demonstrated that seedlings of neither species can tolerate prolonged submergence of their foliage (Mattoon 1916; Teskey and Hinckley 1977; Hook 1984). Therefore, for successful regeneration of cypress and tupelo stands to occur, moist but exposed substrates must exist during portions of the growing season. On both regulated and natural streams, it is unlikely that such conditions will occur every year, or even with a predictable frequency or pattern. As a result, cypress and tupelo stands commonly consist of cohorts of even-aged individuals that become established during those occasional growing seasons when specific environmental conditions favorable for successful seedling establishment occur (Schlesinger 1976).

Major factors potentially responsible for limited regeneration of bald cypress and water tupelo include: (1) low seed production, viability and dispersal, (2) lack of suitable microsites for germination and seedling establishment, (3) physiological and growth restrictions of seedlings exposed to combinations of non-lethal environmental perturbations, and (4) catastrophic environmental events such as major fluctuations in water levels. An evaluation of the relative importance of these factors in limiting the regeneration success of bald cypress and water tupelo in a 3800 ha floodplain forest on the U.S. Department of Energy's Savannah River Plant (SRP) in South Carolina is underway (fig. 1). Here, cypress and tupelo are canopy codominants over 47% of the area (table 1). Examination of the composition of these stands, especially of the representation of individuals in the seedling and sapling size classes, suggests that the dominant canopy species are not being replaced effectively (Sharitz et al. in press).

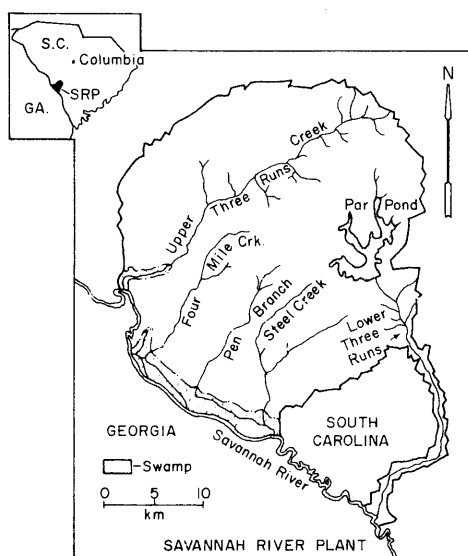

Figure 1.--The Savannah River Plant in South Carolina indicating location of Savannah River floodplain and major tributary streams.

Table 1.--Major plant community types on the SRP Savannah River floodplain (from Jensen et al. 1984).

Community Type	Areal Coverage		Dominant Species
	ha	%	
Persistent Emergent Marsh	54.6	1.4	<u>Typha latifolia</u> <u>Scirpus cyperinus</u> <u>Leersia</u> spp.
Nonpersistent Emergent Marsh	152.2	4.0	<u>Hydrolea quadrivalvis</u> <u>Polygonum</u> spp. <u>Ludwigia</u> spp.
Scrub-Shrub	154.6	4.1	<u>Salix</u> spp. <u>Cephalanthus</u> <u>occidentalis</u>
Mixed Deciduous Swamp Forest	1793.6	47.2	<u>Taxodium distichum</u> <u>Nyssa aquatica</u>
Mixed Deciduous Bottomland Forest	1528.1	40.2	<u>Quercus</u> spp. <u>Acer rubrum</u> <u>Liquidambar</u> <u>styraciflua</u>
Needle-leaved Evergreen Forest	83.4	2.2	<u>Pinus taeda</u>

#### FACTORS AFFECTING REGENERATION

##### Seed Production, Viability and Dispersal

Annual seed production of bald cypress and water tupelo was examined during two consecutive years by trapping dispersing seeds. Floating seed traps were positioned within randomly located 0.20 ha quadrats to quantify seed rain. In addition, water dispersal of seeds was measured to quantify the potential seed input to a given area of the swamp. Tetrazolium and germination tests (Shuel 1948) were used to determine viability and potential for germination success of the second year's seed crop.

During the winter of 1983-1984, seed fall of both species began in September and continued until December for water tupelo and February for bald cypress (Schneider and Sharitz in prep.; Sharitz et al. in press). Seed rain peaked in November at an input of 4 seeds m<sup>-2</sup>day<sup>-1</sup> for cypress and 1 seed m<sup>-2</sup>day<sup>-1</sup> for tupelo. Although seed production was lower in 1984-1985, seed release again occurred in late fall and early winter. During the winter and early spring months of both years, flooding substantially increased potential seed input to sites in the swamp by



several orders of magnitude. Data from the winter of 1983-1984 indicate that as many as 100-200 cypress and tupelo seeds moved across any given m<sup>2</sup> area during periods of high water in January and February (Sharitz et al. in press). However, many of these seeds may not have been deposited on sites suitable for germination.

Although total seed production and availability seem adequate for community regeneration, low seed viability, especially of bald cypress, may be an important limiting factor. Estimates of insect parasitism and seed abortion were made on seeds collected over the two dispersal periods, and viability was tested (Mitchell et al. 1985). Preliminary results in 1983-1984 indicated that 21% of the water tupelo seeds were either aborted or lost to frugivory while in the tree. Insect parasitism was observed in 26% of the cypress seeds. In addition, tetrazolium staining techniques indicated approximately 65% viability of the remaining tupelo seeds and only 12% viability of cypress. Most of the non-viable cypress seeds lacked embryos.

#### Availability of Suitable Microsites

Given an adequate viable seed source, a major factor limiting the success of cypress-tupelo forest regeneration on the Savannah River floodplain is the availability of substrates suitable for germination and seedling establishment. Because floodplain substrates may be inundated during much of the year, microsites that meet the necessary requirements of moist but non-flooded conditions may be unavailable. In cypress-tupelo forests, several microsite types can be distinguished (Huenneke and Sharitz 1985). These include the bases of trees and cypress knees (live wood substrates), stumps, woody debris and fallen logs (dead wood substrates), and several types of organic muck substrates. Microsites differentially trap water dispersed seeds and provide varied conditions for germination and growth, thus affecting seedling recruitment.

The recovery of marked seeds released into the floodplain environment at random locations indicates that potentially more than 50% of the seeds are retained within 500 m of the parent tree. Trapping of these water dispersed seeds occurs differentially among knee, log, stump, tree base and leaf litter microsite types (Schneider and Sharitz 1985). In addition, Huenneke and Sharitz (1985) showed that woody seedlings were distributed not in proportion to the abundance of microsite types. The relative stability of a microsite during winter floods appears to be one determinant of its value as a substrate for successful seedling regeneration.

#### Physiological Restrictions

Although bald cypress and water tupelo have high tolerances to prolonged inundation (Teskey

and Hinckley 1977; Hook 1984), growth and certain physiological processes may be altered under combinations of flooding and other environmental stresses. On the SRP, discharges of heated water from the cooling systems of nuclear reactors increase the temperature and depth of floodplain water and sediments. McLeod and Sherrod (1981) found that moderate increases in water temperature enhanced cypress seedling growth. Similarly, Donovan and McLeod (submitted) observed increases in aboveground and belowground biomass of cypress seedlings at moderately increased water temperatures (5°C above ambient), compared with biomass under ambient conditions. However, after four months' growth under combinations of high temperature (10°C above ambient) and flooding (6 cm above the substrate surface), root carbohydrate concentrations were lower than in seedlings grown under ambient temperatures or non-flooded conditions. These results suggest that reduced carbohydrate storage may be a major factor contributing to the eventual decline of bald cypress seedlings and mature trees in thermally impacted areas of the SRP floodplain forest.

#### Catastrophic Environmental Events

Differential seedling survivorship and growth in various microenvironments will, under natural conditions, limit the number of individuals that survive to become dominants in the wetland forest canopy. However, catastrophic environmental perturbations may control regeneration in many floodplain forests associated with regulated streams. For example, discharges from reservoirs on the Savannah River have modified the annual hydrograph during the past three decades (fig. 2). Maintenance of high river levels during

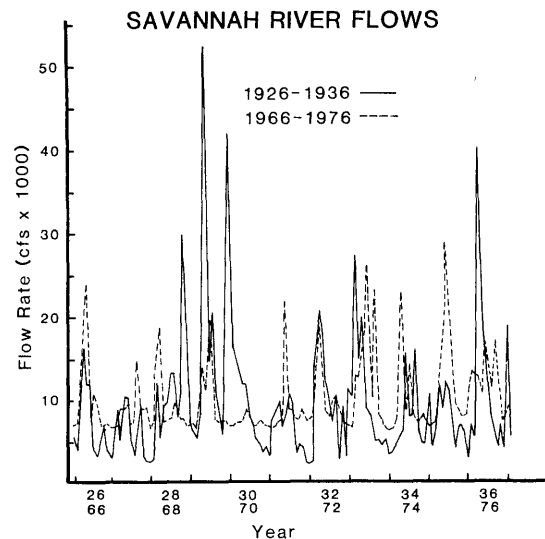

Figure 2. Discharges from reservoirs on the Savannah River have modified the river's annual hydrograph during the past three decades. Annual water level fluctuations at the SRP for a representative interval prior to upstream dam construction (1926-1936) and following dam construction (1966-1976) are compared.

the growing season and continuous inundation of the floodplain may limit tree regeneration success by reducing the availability of exposed substrates suitable for seed germination and seedling establishment. Furthermore, flood events that inundate seedlings during the growing season cause high mortality. Sharitz et al. (in press) reported 89% survival of a cohort of 1200 bald cypress and water tupelo seedlings during the typical winter floods of 1984. However, following two desynchronized floods resulting from abrupt high volume discharges from an upstream reservoir (one during May and the second during early August) seedling mortality was greater than 99% (fig. 3).

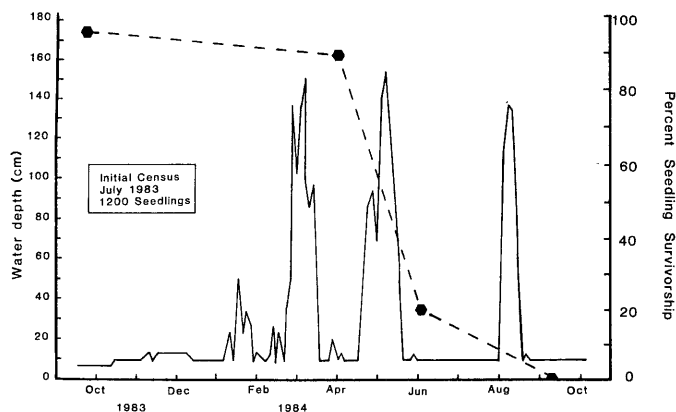

Figure 3. Relationships between percent survivorship of bald cypress and water tupelo seedlings and flood events in the Savannah River floodplain.

#### DISCUSSION

The natural establishment, development and maintenance of floodplain forests in the Southeast is largely dependent on the coincident availability of viable seeds with low water levels during periods in the growing season when germination and seedling establishment can occur. Our understanding of the major factors that limit regeneration in cypress-tupelo forests of the Southeast indicates that alteration of stream discharges without adequate attention to the autoecological requirements of floodplain species is an oversight in current management practices.

Watershed management seldom focuses on maintenance of floodplain wetlands. Most river discharge events in the Southeast are timed for recreational boating and fishing purposes or for electrical power generation. Accurately timed river drawdowns that allow natural wetland ecosystem processes to occur are uncommon. Results of the SRP studies summarized here suggest that major desynchronized floods of the Savannah River have led to degradation of floodplain forest regeneration processes. Although the potential for natural regeneration exists, managed water level changes generally preclude establishment and maintenance of major cohorts of the dominant species on the SRP floodplain. In any given year, failure of seedling establishment is probably not significant. In fact, it appears that

major regeneration events on floodplains of natural rivers of the Southeast are pulsed and relatively infrequent. However, the cumulative impact of annual regeneration failures in floodplain forests is potentially significant.

With increases in water resources development on Southeastern rivers, the potential long-term effects of management practices on floodplain communities should be considered. This study suggests that river discharge management that does not provide for forest regeneration may lead to changes in the structure, productivity and habitat values of floodplain wetlands. Currently, our ability to predict all the consequences of degradation of wetland portions of watersheds is limited. Whereas several studies have addressed impacts to particular sites resulting from water level management (Connor et al. 1981), the relationships between the condition of floodplain forests and major watershed processes have not been addressed. Additional research is necessary to establish watershed management techniques that will satisfy maintenance requirements of floodplain forests.

#### LITERATURE CITED

- Connor, W. H., J. G. Gosselink and R. T. Parrondo. 1981. Comparison of the vegetation of three Louisiana swamp sites with different flooding regimes. *Am. J. Bot.* 68:320-331.
- Donovan, L. A. And K. W. McLeod. Morphological and root carbohydrate responses of bald cypress seedlings to water temperatures and water level regimes. *Therm. Biol.* (submitted).
- Fonda, R. W. 1974. Forest succession in relation to river terrace development in Olympic National Park, Washington. *Ecology* 55:927-942.
- Fowells, H. A. (ed). 1965. *Silvics of forest trees of the United States.* 762 p. USDA For. Ser. Ag. Hdbk. No. 271. Washington, D.C.
- Gardner, A. C. 1980. Regeneration problems and options for white spruce on river flood plains in the Yukon Territory. p. 19-24. *In* Murray, M. and V. Van Velhuizen (eds). *Forest regeneration at high latitudes.* USDA PNW Gen. Tech. Rpt. 107.
- Hawk, G. and D. Zobel. 1974. Forest succession on alluvial landforms of the McKenzie River Valley, OR. *Northwest Sci.* 48: 245-265.
- Hook, D. D. 1984. Waterlogging tolerance of lowland tree species of the south. *So. J. Applied Forestry* 8:136-149.
- Huenneke, L. F. and R. R. Sharitz. 1985. Micro-site abundance and the distribution of woody seedlings in a South Carolina cypress-tupelo swamp. *Am. Midl. Nat.* (in press).

- Jensen, J. R., E. J. Christiansen and R. R. Sharitz. 1984. SRP swamp vegetation map. 29 p. DPST-84-372. E. I. DuPont de Nemours & Co. Aiken, SC.
- Klopatek, J. M. 1978. Nutrient dynamics of freshwater riverine marshes and the role of emergent macrophytes. p. 195-216. In Good, R. E., D. F. Whigham and R. L. Simpson (eds.). *Freshwater wetlands: ecological processes and management potential*. Academic Press, NY.
- Larsen, J. S., M. S. Bedinger, C. F. Bryan, S. Brown, R. T. Huffman, E. L. Miller, D. G. Rhodes and B. A. Touchet. 1981. Transition from wetlands to uplands in southeastern bottomland hardwood forests. p. 225-273. In J. R. Clark and J. Benforado (eds.). *Wetlands of bottomland hardwood forests. Developments in agricultural and managed forest ecology*. Elsevier Sci. Publ. Co. Amsterdam.
- Lee, L. C. 1983. The floodplain and wetland vegetation of two Pacific Northwest river ecosystems. 268 p. Ph.D. Dissertation. Univ. Washington, Seattle.
- Mattoon, W. R. 1916. Water requirements and growth of young cypress. *Soc. Am. For. Proc.* 11:192-197.
- McLeod, K. W. and K. C. Sherrod Jr. 1981. Baldcypress seedling growth in thermally altered habitats. *Am. J. Bot.* 68:918-923.
- Minshall, G.W., R. C. Peterson, K. W. Cummins, T. L. Bott, J. R. Sedell, C. E. Cushing and R. L. Vannote. 1983. Interbiome comparison of stream ecosystem dynamics. *Ecol. Monog.* 53:1-25.
- Mitchell, C. E., R. L. Schneider and R. R. Sharitz. 1985. Seed demography of two floodplain swamp tree species. *Bull. Ecol. Soc. Am.* 66:
- Palmisano, A. W. 1978. Harvest from wetlands. p. 589-597. In Greeson, P. E., J. R. Clark and J. E. Clark (eds). *Wetland functions and values: the state of our understanding*. Am. Water Res. Assoc., Minneapolis, MN.
- Radford, A. E., H. E. Ahles and C. R. Bell. 1968. *Manual of the vascular flora of the Carolinas*. 1183 p. Univ. North Carolina Press. Chapel Hill.
- Robertson, P. A., G. T. Weaver, J. A. Cavanaugh. 1978. Vegetation and tree species patterns near the northern terminus of the southern floodplain forest. *Ecol. Monog.* 48:249-267.
- Schlesinger, W. H. 1976. Biogeochemical limits on two levels of plant community organization in the cypress forest of Okefenokee Swamp. 142 p. Ph.D. Dissertation. Cornell Univ., Ithaca.
- Schneider, R. L. and R. R. Sharitz. Factors affecting seed availability in a southeastern riverine swamp. (in prep.).
- Schneider, R. L. and R. R. Sharitz. 1985. Fate of water-dispersed seeds in a southeastern cypress-tupelo riverine swamp. *Bull. Ecol. Soc. Am.* 66:
- Schopmeyer, C. C. (ed.). 1974. *Seeds of woody plants in the United States*. 883 p. USDA For. Ser. Agric. Hdbk. No. 450. Washington, DC.
- Sharitz, R. R., R. L. Schneider and L. C. Lee. Composition and regeneration of a disturbed river floodplain swamp in South Carolina. *Proc. EPA Bottomland Hardwoods Symp.* St. Francisville, LA. (in press).
- Shuel, R. W. 1948. Seed germinability tests with 2, 3, 5-triphenyltetrazolium chloride. *Sci. Agric.* 28:34-38.
- Sloey, W. E., F. L. Spangler and C. W. Fetter. 1978. Management of freshwater wetlands for nutrient assimilation. p. 321-340. In Good, R.E., D.F. Whigham and R. L. Simpson (eds). *Freshwater wetlands: ecological processes and management potential*. Academic Press, NY.
- Teskey, R. O. and T. M. Hinckley. 1977. Impact of water level changes on woody riparian and wetland communities. 46 p. Vol. II (The southern forest region). *FWS/OBS-77/58*, U.S. Fish & Wildl. Ser. Washington, DC
- Thomas, J. W., C. Maser and J. E. Rodick. 1979. "Riparian zones." p. 40-47. In *Wildlife habitats in managed forests*. USDA For. Ser. Agri. Hdbk. No. 553. Chap. 3.
- Van Cleve, K., T. Dyrness and L. Viereck. 1980. Nutrient cycling in interior Alaska floodplains and its relationship to regeneration and subsequent forest development. p. 11-18. In Murray, M. and R.M. Van Veldhuizen (eds). *Forest regeneration at high latitudes*, Proc. of an Intern. Wkshp., Nov. 15-17, 1979. (Fairbanks, AK). USDA For. Ser. Gen. Tech. Rpt. PNW-107.
- Wharton, C. H., W. M. Kitchens, E. C. Pendleton and T. W. Sipe. 1982. The ecology of bottomland hardwood swamps of the Southeast: a community profile. 133 p. U.S. Fish & Wildl. Ser., *FWS/OBS-81/37*. Washington, DC.
- Whittaker, R. H. and S. A. Levin. 1977. The role of mosaic phenomena in natural communities. *Theoret. Pop. Biol.* 12: 117-139.
- Williams, J. D. and C. K. Dodd. 1978. Importance of wetlands to endangered and threatened species. p. 565-575. In Greeson, P. E., J. R. Clark and J. E. Clark (eds). *Wetland functions and values: the state of our understanding*. Am. Water Res. Assoc., Minneapolis, MN.

# Xeroriparian Systems Used by Desert Mule Deer in Texas And Arizona<sup>1</sup>

Paul R. Krausman<sup>2</sup>, Kurt R. Rautenstrauch<sup>3</sup> and Bruce D. Leopold<sup>4</sup>

---

Abstract.--We examined desert mule deer (Odocoileus hemionus crooki) occurrence in xeroriparian systems in Arizona and Texas. Most deer in Arizona were located in washes. Most deer in Texas were located between washes. Xeroriparian areas are important habitat components for desert mule deer when they provide forage, thermal cover and travel lanes.

---

## INTRODUCTION

Desert mule deer inhabit the Sonoran and Chihuahuan Deserts of North America. Their range extends from southwest Texas to western Arizona and south into central Mexico (Wallmo 1981).

Desert mule deer are a popular and important game animal, but have received limited attention by the scientific community. Clark (1953) examined desert mule deer behavior and movement patterns, Truett (1972) studied their general ecology, Krausman (1978) and Leopold (1984) evaluated their forage preferences, and Krausman (1984) and Rautenstrauch and Krausman (unpublished data) have studied desert mule deer home range size and movements. Descriptions of desert mule deer habitat are general (Phillips 1974, Anthony and Smith 1977, Dickinson and Garner 1979, Koerth 1981, Leopold and Krausman (1983) and there is little published information on desert mule deer habitat use.

We began studying desert mule deer in Texas in 1972 (Krausman and Ables 1981, Leopold 1984), and in Arizona in 1979 (Krausman 1984, Rautenstrauch and Krausman, unpublished data). During these studies it became apparent that xeroriparian washes and their associated vegetation were an important component of desert mule deer habitat. Our objective in this study was to document desert mule deer use of xeroriparian systems (Johnson et al. 1981) across the northern boundary of their range and to describe the vegetation of washes used by deer.

## STUDY AREAS

Desert mule deer use of xeroriparian systems was evaluated on the northeastern edge of their range in Big Bend National Park (BBNP), southwest Texas; in the westcentral part of their range in the Belmont Mountains, central Arizona; and on the northwestern edge of their range in King Valley, southwest Arizona.

BBNP, Brewster Co., is representative of the rugged Chihuahuan Desert and is included in the Chisos biotic district (Dice 1943). Elevations extend from 573 m along the Rio Grande to 2384 m at Mt. Emory in the Chisos Mountains.

BBNP is characterized by hot summers, mild winters and low rainfall. Temperatures exceed 38 C in the desert regions in summer and rarely freeze in winter. Precipitation occurs from May through October, ranging from 28-41 cm.

Leopold and Krausman (1983) identified 10 vegetative associations in BBNP. The associations were differentiated into three categories based on dominant plant cover: creosotebush (Larrea tridentata) dominated, non-creosotebush dominated, and associations not dominated by shrubs.

The Belmont Mountains, Maricopa Co., are 80 km west of Phoenix, cover 360 km<sup>2</sup>, and are representative of the upper Sonoran Desert. Elevations range from 426 m to 914 m.

The average annual precipitation is 20 cm. Most rain falls from January through March. Temperatures above 45 C in summer are common.

---

<sup>1</sup>Paper presented at the first North American Riparian Conference. [University of Arizona, Tucson. April 16-18, 1985].

<sup>2</sup>Paul R. Krausman is Associate Professor of Wildlife, University of Arizona, Tucson, Az.

<sup>3</sup>Kurt R. Rautenstrauch is Graduate Research Assistant, University of Arizona, Tucson, Az.

<sup>4</sup>Bruce D. Leopold is Wildlife Research Assistant, University of Arizona, Tucson, Az.

Krausman (1984) identified 9 vegetative associations in the Belmont Mountains. Most associations are dominated by triangleleaf bursage (Ambrosia deltoidea), brittlebush (Encelia farinosa) and creosotebush. The areas between the mountains and foothills having major washes are classified as the Triangleleaf Bursage-Transition Association. Vegetation in this association is dominated by the same three plants, but the washes

contain the larger trees, ironwood (Olneya tesota) and paloverde (Cercidium spp.).

Over 60% of the Belmont Mountain area is in the Creosote Flats Association. Dominant plants include creosotebush and triangleleaf bursage. The species composition of the major washes is similar to the transition association.

King Valley, Yuma Co., is 45 to 60 km northeast of Yuma and 110 km southwest of the Belmont Mountains. Elevations range from 85 m at the Gila River to 450 m at the base of the surrounding mountains. The average annual precipitation at the lower end of the valley is 12 cm.

The slopes of the mountain ranges surrounding King Valley are sparsely vegetated and dominated by creosotebush, brittlebush, white bursage (Ambrosia dumosa), and ocotillo (Fouquieria splendens). The canyon bottoms have xeroriparian washes dominated by ironwood and paloverde.

Most plant life in King Valley is restricted to the xeroriparian drainages. The areas between drainages are usually covered with wind eroded desert pavement, and have no vegetation or very sparse stands of creosotebush, brittlebush and white bursage.

The dominant overstory species in the washes are little-leaf paloverde (C. microphyllum), blue paloverde (C. floridum) and ironwood. The width of the vegetation in the largest washes in King Valley is over 300 m wide.

Because deer were rarely located in the mountains and foothills surrounding King Valley, this study deals only with the xeroriparian Paloverde-Ironwood Association found in the bottom of King Valley.

## METHODS

### Vegetation Sampling

#### Texas

Twenty five to 50 point-quarter plots (Dix 1961) were sampled in each of ten vegetative associations identified in BBNP (Leopold and Krausman 1983) to determine the density of vegetation between washes.

A transect line was established along the center of each sampled wash running parallel to the flow of water. The initial plot was randomly determined and subsequent points were 15 m apart. At each point, width of wash, and all perennial plant species to the left and right of the point were recorded. We also noted which plants were deer forage. Desirable deer forage plant species was based on diets determined by fecal analysis (Leopold 1984).

#### Arizona

Belmont Mountains.--The density of perennial vegetation was measured in 50-100 0.004-ha randomly located circular plots in each of nine associations identified. In major washes that bisected associations, line intercept transects (Canfield 1941) were established to estimate the vegetational composition in xeroriparian components of the association.

King Valley.--Washes in King Valley were divided into 4 classes depending on the number of drainages and the width of the associated vegetation. Simple washes have only one drainage (a water flume greater than 1 m wide). Complex washes (washes with more than 1 flume) were divided into 3 classes based on the width of the vegetation: less than 50 m wide (C1), between 50 and 150 m wide (C2) and greater than 150 m wide (C3).

The percent cover of perennial vegetation in washes was measured using the line-intercept method (Canfield 1941). Ten transects, spaced ten m apart and running perpendicular to the flow of water, were measured in each wash.

The density of perennial vegetation between washes was measured in six to 10 .0314 ha circular plots next to each wash measured. The plots were either 100 m away from the edge of the wash vegetation or half-way between the measured wash and the adjacent wash if the washes were less than 200 m apart.

### Contrasting Washes and Adjacent Habitat

Shannon-Weaver Diversity indices were computed to contrast plant species diversity in washes and adjacent habitats in Texas and between areas in Arizona. Morisita coefficients of overlap (Morisita 1959) were computed to determine degree of similarity of perennial vegetation within washes and adjacent vegetative associations in Texas. The equivalence of percent forage species occurring in the washes and the adjacent vegetative associations was determined using the binomial test for proportions (Zar 1984:395-400).

### Deer Occurrence in Washes

#### Texas

Deer use of washes was determined from 750 independent observations of deer in three classes: initially observed in wash, within 30 m of a wash, or greater than 30 m from a wash. All observations were made from January 1980 through 1981. Habitats were sampled for deer in proportion to their availability in the study area.

#### Arizona

Deer use of washes was determined from 1180 independent locations of 12 radio-collared deer (4

Table 1.--Summary and comparison of vegetative characteristics of plant associations and adjacent wash systems in Big Bend National Park, Texas.

Vegetative association	Plant association		Wash systems		Diversity		Coefficient of overlap
	Total plant density <sup>1</sup>	Deer forage <sup>2</sup>	Deer forage <sup>2</sup>	Wash width <sup>3</sup>	Adjacent habitat	wash	
I. Creosotebush dominated							
Creo-lech-grass	3.01	43.4* <sup>6</sup>	29.3	18.6	2.25	2.81	0.09
Creo-lech-candel	0.74	28.3	41.3** <sup>7</sup>	23.5	2.31	2.38	0.40
Creo-lech-Opuntia	0.65	27.8	31.1	19.6	1.59	2.58	0.27
Creo-tarbush	2.30	40.1*	26.4	5.4	2.69	2.25	0.50
Creo Flats (Loc 1) <sup>4</sup>	0.64	5.9	8.2	13.3	1.55	1.80	0.66
Creo Flats (Loc 2) <sup>5</sup>	0.04	0.0	55.8**	25.0	1.09	2.37	0.30
Creo-lech	0.24	33.6	55.3**	NA	1.95	1.59	0.32
II. Non-creosotebush dominated							
Vig-lech-grass	2.46	44.3	62.4**	5.5	2.58	2.40	0.76
Yucca-Sotol	4.34	46.8*	23.7	9.7	2.74	2.70	0.37
Sotol-lech-grass	4.05	53.0	60.2	6.3	1.87	2.87	0.25
III. Non-shrub dominated							
Lech-grass (Loc 1)	1.72	68.6*	53.1	3.8	2.73	3.01	0.35
Lech-grass (Loc 2)	1.04	59.1	57.7	5.2	2.35	2.69	0.60

<sup>1</sup> expressed as stems/m<sup>2</sup>

<sup>2</sup> expressed as percentage

<sup>3</sup> expressed as average of all points sampled

<sup>4</sup> Creosotebush Flats of upper elevations

<sup>5</sup> Creosotebush Flats of lower elevations

<sup>6</sup> \*-deer forage in vegetation association significantly greater (alpha = 0.05) than in washes within association

<sup>7</sup> \*\*-deer forage in washes significantly greater (alpha = 0.05) than adjacent association.

males, 8 females) in the Belmont Mountains from 1980-1983, and 870 independent locations of 15 radio-collared deer in King Valley (4 males, 11 females) from 1982-1984. Each collared animal was located weekly with a fixed wing aircraft (Krausman et al. 1984). For each location deer were classified as being in a wash or not in a wash. In King Valley the class of wash being used was also recorded.

## RESULTS

### Characteristics of Xeroriparian Systems

The average width of washes sampled in BBNP ranged from 3.8 m to 25.0 m (table 1). In general, wash systems in the lower plant density associations were wider than those with high plant density associations.

Washes in the Belmont Mountains are similar in size to those in BBNP. The largest washes in King Valley are wider than washes in the two other study sites. The average width of C<sub>3</sub> washes is 284 m, and the largest washes measured were over 350 m wide.

### Contrasting Washes and Adjacent Habitat

In all 3 study areas the species composition in wash systems was not similar to the species

composition of adjacent habitats. This difference was smallest in BBNP and greatest in King Valley.

### Texas

Plant species within wash systems was not similar to the perennial species composition of adjacent habitats. Coefficients of overlap rarely exceeded 0.60 (table 1) which represents significant biological overlap (Alcoze and Zimmerman 1973).

Plant species diversity was greater in washes than in adjacent habitats for all but 4 plant associations. As equal number of associations had significantly greater forage percentages in washes than in adjacent habitats (table 1). The wash systems in low density creosotebush dominated associations were generally more diverse and had greater deer forage percentages than the adjacent habitats. Deer using plant associations with low plant densities may therefore find higher diversity and more forage in washes than in the adjacent habitat.

### Arizona

Belmont Mountains.--Plant species within wash systems (tables 2, 3) was not similar to the perennial species composition of adjacent habitats. The plant species composition of washes was more diverse than that of the surrounding

Table 2.--Vegetation in xeroriparian systems associated with the Triangleleaf bursage-Transition Association, Belmont Mountains, Arizona.

Plant species	% cover
<u>Olneya tesota</u>	13.54
<u>Larrea tridentata</u>	5.58
<u>Cercidium microphyllum</u>	4.06
<u>Cercidium floridum</u>	3.48
<u>Prosopis juliflora</u>	1.90
<u>Lycium andersonii</u>	1.64
<u>Haplopappus larcifolius</u>	1.11
<u>Acacia greggii</u>	T
<u>Ambrosia ambrosioides</u>	T
<u>Ambrosia deltoidea</u>	T
<u>Condalia spathulata</u>	T
<u>Encelia farinosa</u>	T
<u>Hyptis emoryi</u>	T
<u>Krameria grayi</u>	T
<u>Simmondsia chinensis</u>	T
Total % cover	33.71
Diversity	1.91

<sup>1</sup> T = <1% cover)

Table 3.--Vegetation in xeroriparian systems associated with the Creosote Flats Association, Belmont Mountains, Arizona.

Plant species	Northern washes	Southern washes
	% cover	
<u>Olneya tesota</u>	2.60	9.65
<u>Cercidium microphyllum</u>	1.97	8.34
<u>Larrea tridentata</u>	8.17	5.46
<u>Cercidium floridum</u>	7.63	4.92
<u>Lycium andersonii</u>	4.82	3.84
<u>Ambrosia deltoidea</u>	1.84	2.41
<u>Acacia greggii</u>	2.34	1.51
<u>Prosopis juliflora</u>	T <sup>1</sup>	1.36
<u>Ambrosia ambrosioides</u>	T	1.29
<u>Acacia constricta</u>	1.30	T
<u>Haplopappus larcifolius</u>	0	T
<u>Condalia spathulata</u>	0	T
<u>Encelia farinosa</u>	0	T
<u>Fouquieria splendens</u>	0	T
<u>Hyptis emoryi</u>	0	T
<u>Krameria grayi</u>	0	T
<u>Lycium spp.</u>	0	T
<u>Opuntia leptocaulis</u>	0	T
<u>Simmondsia chinensis</u>	0	T
<u>Sphaeralcea spp.</u>	0	T
Total % cover	31.27	39.11
Diversity	2.01	2.24

<sup>1</sup> T = <1% cover)

Table 4.--Density (#/hectare) of perennial plants in the Cresoste Flats (CF) and Triangleleaf bursage-Transition (TBT) Associations, Belmont Mountains, and in the Paloverde-Ironwood (PI) Association in King Valley, Arizona.

Species	Belmont Mountains King Valley		
	TBT	CF	PI
<u>Krameria spp.</u>	12.5	32.5	T <sup>1</sup>
<u>Larrea tridentata</u>	280	712.5	70
<u>Carnegia gigantea</u>	12.5	2.5	T
<u>Opuntia spp.</u>	500	7.5	4.2
<u>Fouquieria splendens</u>	12.5		T
<u>Ambrosia dumosa</u>	2.5		10.4
<u>Ambrosia deltoidea</u>	1332.5	417.5	
<u>Encelia farinosa</u>	125	35	13.4
Other	25	25	T
Total	2302.5	1232.5	141.0
Diversity (H')	1.31	1.01	1.00

<sup>1</sup>less than 1 plant/ha

vegetation and provided a higher density of forage and cover than adjacent areas.

King Valley.--The average density of perennial vegetation in the habitat adjacent to washes in King Valley was 1.4 plants/100 m<sup>2</sup> (table 4). These areas provide very little forage for deer and have no shaded bedsites. Most preferred forage species, such as ironwood, ratany, and blue paloverde are uncommon or not found outside of the washes. Because the nonwash habitat has no overstory species and the common shrubs are small, there are no shaded bedsites in these areas. Over 8% of the groundcover in washes is overstory species that provided bedsites for deer (table 5).

#### Deer Occurance in Washes

##### Texas

Of 750 deer observations only 40 (5.3%) occurred within a wash, and 29 (3.9%) within 30 m of a wash.

##### Arizona

Belmont Mountains.--Deer use of xeroriparian systems was highest in summer (83.3%) followed by fall (82.2%) and spring (70.5%) (table 6). During the winter deer use of washes was 42.1%. Overall, 842 of 1180 (71.4%) deer were located in washes (table 6).

King Valley.--Over 99% of the deer locations in King Valley were in washes (table 7). The six locations that were not in washes were either in

Table 5.--Percent cover of vegetation in 4 wash classes in King Valley, Arizona.

	Simple	C1	C2	C3
Av. width of wash	15.74	39.51	89.62	284.3
Av. % cover of vegetation	30.40	29.36	23.76	24.77
Av. # drainages	1.0	3.2	6.93	12.95
Av. # of species	7.5	9.05	9.32	10.75
Av. % of overstory cover	10.55	8.84	8.46	8.05
<i>Hilaria rigida</i>	0.05	1.02	0.08	
<i>Atriplex polycarpa</i>	0.28	0.94	0.11	0.56
<i>Acacia greggi</i>	0.19	0.35	0.41	0.79
<i>Prosopis juliflora</i>	0.30	0.10	0.03	0.52
<i>Krameria grayi</i>	0.96	0.25	0.13	0.25
<i>Cercidium microphyllum</i>	3.54	1.88	1.42	0.24
<i>C. floridum</i>	1.42	2.55	3.28	5.64
<i>Olneya tesota</i>	5.10	3.96	3.32	0.81
<i>Larrea tridentata</i>	10.48	11.89	11.05	9.97
<i>Sphaeralcea</i> spp.	0.18	0.31	0.23	2.52
<i>Lycium andersonii</i>	3.60	2.85	2.56	3.47
<i>Ambrosia dumosa</i>	3.12	1.18	0.65	0.16
<i>Encelia farinosa</i>	2.57	2.94	1.67	0.55
Other species	0.86	1.28	1.09	1.38
Diversity (H')	2.10	2.12	1.93	2.03

agriculture fields or disturbed areas near agriculture at the south end of King Valley.

#### DISCUSSION

Deer in BBNP are not as dependent upon xeroriparian systems as deer in Arizona. In Texas, deer forage is abundant in the habitats adjacent to wash systems. Although the plant species composition of washes and adjacent habitats are not similar, both areas have relatively equal diversity, except in plant associations with low plant densities. Deer use of these areas was minimal (<1.0 deer/km<sup>2</sup>) compared to plant associations with higher plant densities (>1.5/deer km<sup>2</sup>) (Leopold 1984). The greater plant densities and diversities in the interwash regions in BBNP allows deer to find forage and cover in these areas instead of in washes, as deer in Arizona must.

Table 6.--Desert mule deer (4 males, 8 females) occurrence in washes in the Belmont Mountains, Arizona from 1981-1982.

Habitat	SEASONS									
	Jan-Mar		Apr-Jun		Jul-Sep		Oct-Dec		Total	
	Wash	Other	Wash	Other	Wash	Other	Wash	Other	Wash	Other
Occurrences	82	113	322	135	304	61	134	29	842	338
Percent occurrences in washes	42.1%		70.5%		83.3%		82.2%		71.4%	

Table 7.--The number (and percent) of deer locations in 4 wash classes in King Valley, Arizona.

	Simple	C1	C2	C3	Other
Females	47 (9.8)	184 (39.1)	172 (36.6)	62 (13.2)	5 (1.1)
Males	32 (18.6)	44 (25.6)	67 (39.0)	28 (16.3)	1 (0.1)

In Arizona, most deer were located in washes. In both Arizona study areas the plant species diversity was twice as high in the xeroriparian washes. Food and cover was scarce outside of these washes in King Valley and less abundant than in washes in the Belmont Mountains. Desert mule deer in Arizona may be selecting xeroriparian washes because they provide more food, cover, and travel lanes than the surrounding areas. Xeroriparian systems are an important part of desert mule deer habitat in xeric ranges.

#### LITERATURE CITED

- Alcoze, T. M., and E. G. Zimmerman. 1973. Food habits and dietary overlap of two heteromyid rodents from the mesquite plains of Texas. *J. Mammal.* 54:900-908.
- Anthony, R. G., and N. S. Smith. 1977. Ecological relationships between mule deer and white-tailed deer in southeastern Arizona. *Ecol. Monogr.* 47:255-277.
- Canfield, R. H. 1941. Application of the line interception method in sampling range vegetation. *J. For.* 39:388-394.
- Clark, E. D. 1953. A study of the behavior and movements of the Tucson Mountain mule deer. M.S. Thesis, Univ. Arizona, Tucson. 111 p.
- Dice, L. R. 1943. The biotic provinces of North America. Univ. Michigan Press, Ann Arbor. 78 p.
- Dickinson, T. G., and G. W. Garner. 1979. Home range use and movements of desert mule deer in southwestern Texas. *Proc. Ann. Conf. S.E. Assoc. Fish and Wildl. Agencies* 33:267-278.



- Dix, R. L. 1969. An application of the point-centered quarter method of the sampling of grassland vegetation. *J. Range Manage.* 14:63-69.
- Johnson, R. R., S. W. Carothers, and J. M. Simpson. 1981. A riparian classification system. p 375-382 *in* R. E. Warner, and K. M. Hendrix, eds. *California riparian systems: ecology, conservation, and productive management.* Univ. of California Press, Berkeley. 1035 p.
- Koerth, B. H., Jr. 1981. Habitat use, herd ecology, and seasonal movements of mule deer in the Texas Panhandle. M.S. Thesis, Texas Tech Univ., Lubbock. 103 p.
- Krausman, P. R., and E. D. Ables. 1981. Ecology of the Carmen Mountains white-tailed deer. *National Park Service Sci. Monogr.* 15:1-114.
- \_\_\_\_\_, J. J. Hervert, and L. L. Ordway. 1984. Radio tracking desert mule deer and bighorn sheep with light aircraft. pp. 115-118 *in* P. R. Krausman and N. S. Smith, eds. *Deer in the southwest: a workshop.* School of Renewable Natural Resources, Univ. of Arizona, Tucson, Arizona.
- \_\_\_\_\_. 1978. Forage relationships between two deer species in Big Bend National Park, Texas. *J. Wildl. Manage.* 42:101-107.
- \_\_\_\_\_, 1984. Impacts of the Central Arizona Project on desert mule deer and desert bighorn sheep. Final Rept. 9-07-30-X069 to USDI/B.R. Phoenix, Arizona.
- Leopold, B. D. 1984. Ecology of desert mule deer in Big Bend National Park, Texas. Ph.D. Dissertation, Univ. Arizona, Tucson. 172 p.
- \_\_\_\_\_, and P. R. Krausman. 1983. Plant communities of the lower desert shrubland in Big Bend National Park, Texas. Second Chihuahuan Desert Symposium, Alpine, Texas. In Press.
- Morista, M. 1959. Measuring of interspecific association and similarity between communities. *Mem. Fac. Sci. Kyushu Univ., Ser. E. Biol.* 3:65-80.
- Phillips, J. L. 1974. The annual behavioral cycle of desert mule deer (*Odocoileus hemionus crooki*) in relation to vegetative use. M.S. Thesis, Sul Ross State Univ., Alpine, Texas. 60 p.
- Truett, J. C. 1972. Ecology of the desert mule deer, *Odocoileus hemionus crooki* Mearns in southeastern Arizona. Ph.D. Dissertation, Univ. Arizona, Tucson. 64 p.
- Wallmo, O. C. 1981. Mule and black-tailed deer distribution and habitats. pp. 1-25 *in* O. C. Wallmo, ed. *Mule and black-tailed deer of North America.* Univ. Nebraska Press, Lincoln. 605 p.
- Zar, J. H. 1974. *Biostatistical analysis.* Prentice-Hall Inc., Englewood Cliffs, N.J. 620 p.

# Gradient Analysis of a Sonoran Desert Wash<sup>1</sup>

2

Peter L. Warren and L. Susan Anderson

---

Abstract.--Vegetation was sampled along two parallel environmental gradients in the Sonoran Desert, one in upland bajada sites and one in xeroriparian wash sites. The wash gradient was found to be more complex than the upland gradient, with three areas of plant species turnover compared to no turnover along the upland gradient. The more complex pattern of the wash gradient is likely due to the interactions of three major limiting environmental factors related to watershed area acting in different portions of the wash gradient, whereas the upland gradient is controlled by one overriding environmental factor.

---

## INTRODUCTION

Vegetation in the deserts of southwestern North America has been studied systematically since the opening of the Carnegie Desert Botanical Laboratory in 1902. Plant ecology of this desert region is probably better known than any similar arid region in the world. Much of this research has concentrated on patterns of vegetation distribution along desert bajadas, the gently sloping plains of coalesced alluvial fans extending from the mountain foothills to the flat valley floors.

Desert washes dissecting the bajada plain are easily recognizable by the corridor of vegetation along their channels that contrasts strongly with the sparse vegetation of adjacent uplands. A transect across a typical Sonoran Desert bajada intercepts an average of approximately 14 desert washes per mile. At an average riparian corridor width of 25 feet, between six and seven percent of total bajada surface area is covered by desert wash vegetation. The intermittent nature of these watercourses results in less luxuriant vegetation than is found along streams with permanent flow, and they have been termed xeroriparian systems (Johnson et al, 1981). Runoff from surrounding slopes increases the available water in and near the wash permitting growth of plant species not found in the surrounding desertscrub. The plants

in turn support animals that are rare or absent in the upland habitats (Lowe, 1964). For these reasons xeroriparian habitats have long been recognized as contributing to the biotic diversity of desert environments in disproportion to their area (Shreve, 1951).

Despite their importance in desert ecosystems, xeroriparian systems have been the subject of remarkably little research. There are several reasons for this. First, riparian biologists have focused most of their attention on systems with permanent water to the exclusion of desert washes (Campbell and Green, 1968; Brown et al., 1981; Minckley and Brown, 1984). Second, studies of desert vegetation distribution patterns have focused on the upland bajada gradient and expressly avoided xeroriparian corridors, treating them only as a factor that might throw confusion into the general pattern of bajada vegetation. Thus, plant distribution patterns along desert washes have been largely ignored by riparian ecologists on one side and desert plant ecologists on the other.

In this paper we attempt to answer three questions: 1) What are the patterns of vegetation distribution in a xeroriparian drainage system? 2) How does the pattern of riparian vegetation compare to the surrounding bajada vegetation gradient? 3) What environmental controlling factors might account for xeroriparian vegetation distribution?

---

1

Paper presented at the First North American Riparian Conference [University of Arizona, Tucson, April 16-18, 1985].

2

Peter L. Warren is a Research Assistant at the Arizona Remote Sensing Center, Office of Arid Lands Studies, University of Arizona, Tucson, Arizona. L. Susan Anderson is a Research Ecologist with the Cooperative Park Studies Unit, University of Arizona, Tucson, Arizona.

## METHODS

We examined a simple, dendritic, xeroriparian drainage system flowing from the west slopes of the Ajo Mountains west across the Ajo Valley in Organ Pipe Cactus National Monument. This area receives an average of 6-8 inches of rain per

year. At this level of precipitation washes carry water only a few days per year, and in some years may not flow at all.

A series of paired upland and riparian sites were sampled along wash and adjacent bajada gradients. Elevation of sample sites ranged from 2300 feet at the foot of the Ajo Mountains at Alamo Canyon to 1400 feet in Growler Valley. A total of 33 riparian and 22 upland sites were sampled. Fewer upland samples were taken because some upland samples were associated with more than one wash sample if they occupied an interfluvial site between two wash tributary samples of different size.

Sites were selected with the aid of aerial photographs approximately every 1 to 2 miles along the length of the major tributary and represented a range of stream orders and watershed areas for the drainage system (Johnson et al., 1984). Sites were selected to avoid problems such as anastomosing channels. Every site sampled was characterized by a single channel that carried all of the flow from the watershed area upstream.

Vegetation sampling involved compiling a complete plant species list for each site and assigning each species a prominence value from 1 to 5 based on its abundance at the site. Wash samples included the entire width of the riparian corridor and extended approximately 100 meters along the stream channel. This resulted in a greater sampling area for larger washes because they have a wider channel and riparian corridor. Adjacent upland bajada samples covered an area of approximately one-half hectare.

Physical features recorded for each site included elevation, watershed area, stream order, channel width, and corridor width. These were determined from aerial photographs and topographic maps, depending upon the scale appropriate to the site.

Cluster analysis was used to compare floristic similarity between sites and determine degree of association between groups of sites. The similarity value is based on the euclidian distance, the square root of the sums-of-squares of the differences between species prominence values for each pair of sites. A larger value indicates a greater degree of floristic difference. Sites with identical species composition and prominence values would show zero difference. A combination of statistical and graphical analysis was used to examine patterns of diversity and species turnover along both the riparian and upland gradients.

## RESULTS AND DISCUSSION

The upland gradient follows a pattern similar to that documented by other studies of desert bajadas: species diversity declines continuously from higher to lower sites with very little species turnover (Fig. 1A). Species present on higher sites decline in abundance at decreasing elevation and disappear, but are not replaced by new species at lower elevations. Only two species, creosotebush and white-bursage, show an increase in abundance at the lowest sites, while the other nine common upland species all decline (Table 1). Few species have higher prominence at

Table 1.--Average prominence and species frequency (percent of sites encountered) in three upland bajada elevation zones along the Alamo-Cherioni-Growler wash system at Organ Pipe Cactus National Monument. These elevation zones correspond to vegetation assemblages of the species rich upper bajada, transitional middle bajada, and the depauperate lower bajada.

Species	2300-1900'		1900-1600'		1600-1300'	
	n=10		n=7		n=5	
	prom.	freq.	prom.	freq.	prom.	freq.
<u>Ambrosia deltoidea</u>	4.0	100	1.6	57	1.2	40
<u>Larrea tridentata</u>	3.7	100	4.6	100	5.0	100
<u>Fouquieria splendens</u>	2.8	100	1.3	57	0.4	20
<u>Carnegiea gigantea</u>	3.1	100	1.7	71	1.4	60
<u>Cercidium microphyllum</u>	2.5	100	1.4	57	0.4	20
<u>Opuntia fulgida</u>	2.9	100	0.9	43	0.2	20
<u>Krameria grayi</u>	1.7	80	1.6	71	0.6	60
<u>Opuntia acanthocarpa</u>	1.9	90	0.3	14	0.6	40
<u>Olneya tesota</u>	1.1	50	0.9	43	0.4	40
<u>Ambrosia dumosa</u>	0.6	30	2.0	71	2.2	80
<u>Lycium andersonii</u>	0.8	50	0.3	29	-	-
<u>Prosopis glandulosa</u>	0.2	10	-	-	-	-

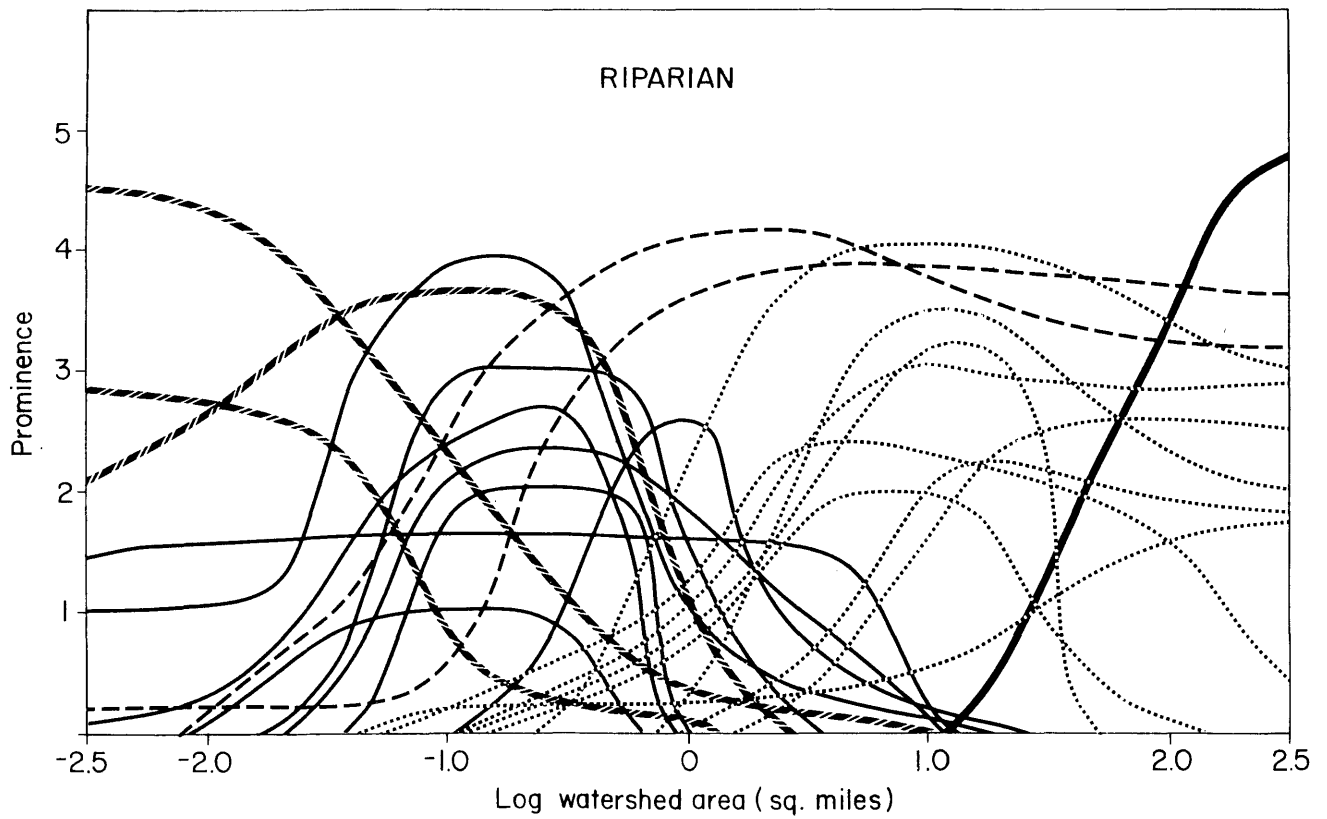
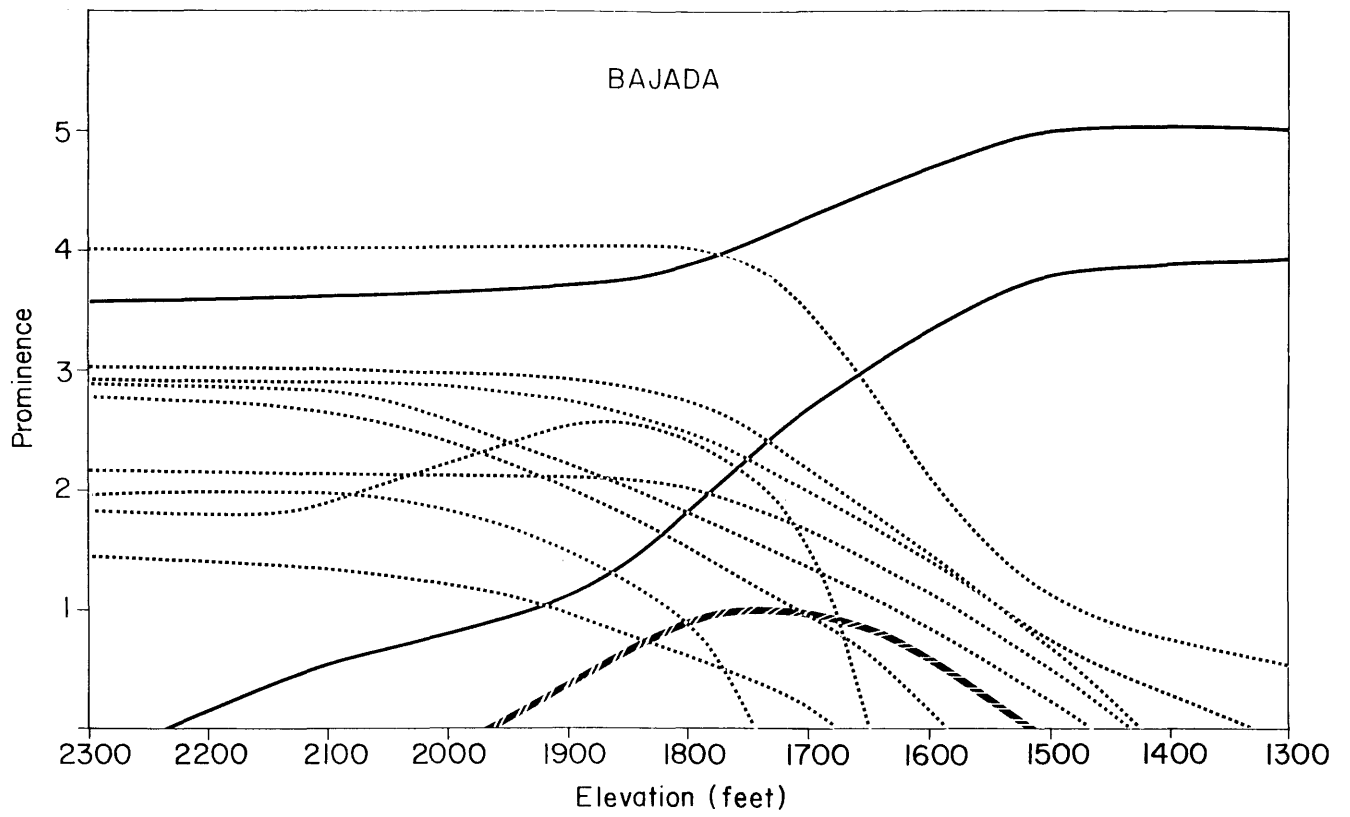

Figure 1.--Comparison of plant species distributions along upland and xeroriparian gradients in the Sonoran Desert. The upland gradient (A) exhibits a continuous decline in diversity with decreasing elevation. The riparian gradient (B) is more complex with three major areas of species turnover.

intermediate sites. Growth form diversity parallels general species diversity. The numerous growth forms present at the top of the gradient, including trees, shrubs, and stem succulents, decline to one dominant form at the bottom.

This pattern of decreasing vegetation diversity along bajada elevational gradients has been documented at numerous sites throughout the Sonoran Desert. Near the southern edge of the desert Felger (1966) studied bajadas along the coast of Sonora. At the northeast margin of the desert, bajada gradients have been documented in at least three locations (Yang and Lowe, 1956; Whittaker and Niering, 1965; Lowe et al., 1973). Phillips and McMahon (1978) examined a bajada in the north central Sonoran Desert, and Yeaton and Cody (1979) studied a northwestern location at the transition between the Sonoran and Mojave deserts. In all of these studies the same basic pattern of decreasing diversity with decreasing elevation was observed.

The primary environmental factor controlling this pattern of decreasing diversity on desert bajadas is available soil moisture (Klikoff, 1967). Under the same rainfall regime, the coarse, rocky soil of the upper bajadas has more

available soil moisture than the heavier silty-loam of the valley bottom by virtue of its higher infiltration rate and lower soil water potential.

Water is likely to also be the primary limiting factor along the xeroriparian gradient, however it probably does not control species distribution simply as a function of plant-available soil moisture throughout the gradient. The frequency, volume, and duration of flow along washes of different size is a function of both watershed area and the regional rainfall regime. The most important and easily measured variable affecting frequency and amount of runoff is watershed area. Therefore, we used watershed area as our primary axis for ordination of species distribution.

The riparian vegetation gradient shows several important differences from the upland gradient, suggesting that the controlling environmental factors for riparian vegetation operate differently from those in the upland community. The riparian gradient differs from the bajada gradient in two major ways. First, there is higher species turnover and therefore higher between site diversity along the riparian corridor. Second, there is greater floristic

Table 2.--Average prominence and species frequency (percent of sites encountered) in four watershed area classes encountered along the Alamo-Cherioni-Growler wash system at Organ Pipe Cactus National Monument. The four zones are defined by watershed area and species distribution patterns: Class 1 is 0.002-0.02 sq. mi., Class 2 is 0.02-0.8 sq. mi., Class 3 is 0.9-50 sq. mi., and Class 4 is 60-400 sq. mi. For a more complete species list see Johnson et al. (1984).

Species	Class 1 n=9		Class 2 n=9		Class 3 n=11		Class 4 n=4	
	prom.	freq.	prom.	freq.	prom.	freq.	prom.	freq.
<u>Krameria grayi</u>	1.7	56	0.8	44	0.1	9	-	-
<u>Cercidium microphyllum</u>	1.3	67	2.8	89	0.7	27	-	-
<u>Ambrosia deltoidea</u>	4.0	100	3.2	89	0.9	54	0.5	25
<u>Condalia spathulata</u>	0.8	44	1.0	56	0.9	45	-	-
<u>Acacia constricta</u>	0.9	44	2.9	89	0.7	36	0.2	25
<u>Sarcostemma cynanchoides</u>	0.1	11	0.1	11	0.4	36	1.2	75
<u>Sphaeralcea sp.</u>	0.1	11	0.3	22	1.4	73	1.8	75
<u>Prosopis glandulosa</u>	0.2	11	1.2	44	3.2	100	3.3	100
<u>Acacia greggii</u>	0.3	22	1.8	89	3.4	100	3.5	100
<u>Plumbago scandens</u>	-	-	0.4	44	-	-	-	-
<u>Ephedra nevadensis</u>	-	-	0.8	33	-	-	-	-
<u>Brickellia californica</u>	-	-	1.6	67	0.4	27	-	-
<u>Celtis pallida</u>	-	-	1.2	67	0.4	27	-	-
<u>Aloysia wrightii</u>	-	-	1.0	56	0.3	27	-	-
<u>Penstemon parryi</u>	-	-	0.4	33	0.9	67	-	-
<u>Zizyphus obtusifolia</u>	-	-	0.3	33	0.9	67	0.5	50
<u>Anisacanthus thurberi</u>	-	-	0.3	11	1.1	54	0.5	50
<u>Ambrosia ambrosioides</u>	-	-	0.3	22	0.9	36	2.2	75
<u>Cercidium floridum</u>	-	-	0.3	11	2.6	82	1.2	50
<u>Baccharis sarothroides</u>	-	-	-	-	1.5	82	1.5	75
<u>Nicotiana trigonophylla</u>	-	-	-	-	1.0	54	1.2	75
<u>Clematis drummondii</u>	-	-	-	-	1.1	46	2.0	75
<u>Hymenoclea salsola</u>	-	-	-	-	0.3	27	3.5	100

differentiation between different portions of the riparian gradient.

Plant species distribution along the continuum of watershed area shows three relatively distinct areas of species turnover (Fig. 1B). These turnover points, characterized by coincident decline and loss of some species and addition and increase of others, occur at approximately 0.02 square miles, just under 1.0 square miles, and 40-50 square miles. The presence of multiple turnover points along the xeroriparian gradient suggests that several environmental variables are operating to limit species distribution and that they operate in a reciprocal fashion with different factors operating to a greater or lesser degree in different portions of the continuum of watershed area (Whittaker, 1967).

A somewhat unexpected observation is that a number of species share similar distribution patterns along the gradient, increasing, decreasing, and reaching maximum prominence over the same portion of the watershed area continuum. The result is the formation of four species assemblages, demarcated by the areas of turnover discussed above, along washes with different watershed area. The environmental factors controlling the species composition of each of the floristic classes can be inferred from the ecological distribution of the dominant species in each assemblage (Table 2).

The first floristic class is associated with small washes with watershed area under 0.02 square miles. In these small washes the dominant species are those with predominately non-riparian distributions such as Cercidium microphyllum, Ambrosia deltoidea, and Krameria grayi. Although a few preferential riparian species are found in these washes, the watersheds are too small to substantially increase available moisture above that supplied by ambient precipitation. These drainages probably do not flow every year and cannot support many preferential or obligate riparian species.

The second floristic class is dominated by preferential and obligate riparian shrubs such as Acacia constricta, Celtis pallida, Brickellia californica, and Aloisia wrightii. This first major species turnover is probably controlled by the watershed area threshold at which increased moisture is reliably greater than that supplied by ambient precipitation. These larger washes, with watershed areas greater than 0.02 square miles, probably flow almost every year. The increased runoff allows faster-growing riparian shrubs to replace the non-riparian species which dominated the smallest washes.

The third floristic class includes moderate to large watersheds with areas from just under 1 square mile up to approximately 50 square miles. The riparian corridor of these washes is dominated by trees, mostly Prosopis glandulosa, Cercidium floridum, and Acacia greggii. Two of these species, Prosopis and Acacia, are present in shrub form in smaller washes, but only achieve tree size in washes with watershed areas greater than 1 square mile. Species turnover associated with the shift to dominance by trees is characterized by

the loss of many of the preferential and obligate riparian shrubs that dominate the second class. These shrubs are replaced by a group of shade-tolerant shrubs which grow under or in the canopies of the overstory trees. The primary limiting factor controlling the second area of species turnover appears to be shading by trees and consequent loss of the shade-intolerant shrubs that dominate the second floristic class.

The fourth floristic class is characterized by two distinct vegetated areas, the tree dominated banks and floodplain, and a shrub dominated channel. The trees that became dominant in the third zone remain so here. The channel itself supports stands of scour resistant species including Hymenoclea salsola, Ambrosia ambrosioides, and Baccharis sarothroides. The factors limiting species distribution in washes with the largest watershed areas appears to be a combination of scouring in the open channels and shading along the heavily vegetated banks and floodplains.

The xeroriparian gradient is much more complex than the upland gradient. The average floristic similarity index among sites in the riparian gradient is almost twice the average for the upland gradient, indicating a higher degree of floristic differentiation between wash sites. In addition, species distributions along the xeroriparian gradient are controlled by at least three environmental factors in contrast to the single overriding factor along the upland gradient. These results suggest that ecological response and/or recovery of xeroriparian vegetation following disturbance may be different from upland vegetation, and generalizations drawn from studies of upland vegetation should not be extended to xeroriparian habitats.

#### CONCLUSIONS

The gradient of xeroriparian vegetation along a Sonoran Desert wash is more complex than the adjacent upland gradient because it is controlled by several interacting environmental factors related to watershed area, while the upland gradient is controlled by one overriding factor. The riparian corridor shows three areas of species turnover and four distinct vegetation classes controlled by frequency and amount of runoff, shading, and channel scouring mitigated by watershed area.

For these reasons, riparian vegetation will likely respond differently to disturbance than surrounding uplands. Riparian vegetation is subject to high levels of natural disturbance and may recover more rapidly than upland vegetation. However, it may be more difficult to evaluate the extent of recovery of riparian vegetation because the expected natural diversity is the result of a complex interaction of watershed area above a specific site, and the regional precipitation regime. Recovery of vegetation structure in xeroriparian habitats may be rapid compared to recovery of species diversity.

#### ACKNOWLEDGEMENTS

Several of the ideas presented here were developed during discussions with R.R. Johnson and C.H. Lowe. R.R. Johnson participated in the field work and the Organ Pipe staff, especially Dick Anderson and Bill Mikus, provided logistical assistance. This research was supported by the Cooperative National Park Resources Studies Unit at University of Arizona.

#### LITERATURE CITED

- Brown, D.E., N.B. Carmony and R.M. Turner. 1981. Drainage map of Arizona showing perennial streams and some important wetlands. Ariz. Game and Fish Dept., map scale 1:1,000,000.
- Campbell, C.J. and W. Green. 1968. Perpetual succession of stream-channel vegetation in a semiarid region. Jour. Ariz. Acad. Sci. 5:86-98.
- Felger, R.S. 1966. Ecology of the gulf coast and islands of Sonora. Ph.D. Dissertation. Univ. Ariz., 460 pp.
- Johnson, R.R., S.W. Carothers and J.M. Simpson. 1981. A riparian classification system. In: Warner and Hendrix. eds. California riparian systems: A conference on their ecology, conservation and productive management. Univ. Calif., Davis. Sept. 17-19, 1981.
- Johnson, R.R., P.L. Warren, L.S. Anderson and C.H. Lowe. 1984. Stream order in ephemeral watercourses: a preliminary analysis from the Sonoran Desert. Hydrology and water resources in Arizona and the Southwest--Proceedings of the American Water Resources Association, Arizona section. 14:89-100.
- Klikoff, L.G. 1967. Moisture stress in a vegetational continuum in the Sonoran Desert. Amer. Midland. Natur. 77:129-137.
- Lowe, C.H. 1964. Arizona landscapes and habitats. In: C.H. Lowe, ed. The vertebrates of Arizona. Univ. Ariz. Press, Tucson.
- Lowe, C.H., J.H. Morello, G. Goldstein, J. Cross and R. Newman. 1973. Analisis comparativo de la vegetacion de los desiertos subtropicales de Norte y Sud America (Monte-Sonoran). Asociacion Argentina de Ecologia, Ecologia. 1:35-43.
- Minckley, W.L. and D.E. Brown. 1984. Wetlands. In: D.E. Brown. ed. Biotic communities of the American Southwest-United States and Mexico. Desert Plants. 4:223-287.
- Phillips, D. and J.A. McMahon. 1978. Gradient analysis of a Sonoran Desert bajada. Southwest Naturalist. 23:669-680.
- Shreve, F. 1951. Vegetation of the Sonoran Desert. Carnegie Inst. Washington, Pub. 591, 192 p.
- Whittaker, R.H. 1967. Gradient analysis of vegetation. Biol. Rev. 42:207-264.
- Whittaker, R.H. and W.A. Niering. 1965. Vegetation of the Santa Catalina mountains, Arizona (II). A gradient analysis of the south slope. Ecology. 46:429-452.
- Yang, T.W. and C.H. Lowe. 1956. Correlation of major vegetation climaxes with soil characteristics in the Sonoran Desert. Science 6:41-45
- Yeaton, R.I. and M.L. Cody. 1979. The distribution of cacti along environmental gradients in the Sonoran and Mojave deserts. J. Ecology. 65:529-541.

# Avian Use of Xeroriparian Ecosystems in the North American Warm Deserts<sup>1</sup>

R. Roy Johnson<sup>2</sup> and Lois T. Haight<sup>2</sup>

---

Abstract.--Results of xeroriparian avian censuses are compared with paired desert upland censuses for various subdivisions of the Sonoran Desert. With few exceptions xeroriparian habitat supports 5 to 10 times the population densities and species diversity of surrounding desert uplands.

---

## INTRODUCTION AND BACKGROUND

The value of riparian ecosystems as avian habitat was first quantified in the late 1960's and early 1970's (Carothers and Johnson 1971, Johnson 1971, Carothers et al. 1974). These earlier avian investigations, however, dealt entirely with wet riparian ecosystems (hydroriparian and mesoriparian) and although dry riparian habitats had been defined a decade earlier as "desert riparian" (Lowe 1961), little has been done either qualitatively or quantitatively to further characterize these xeroriparian ecosystems.

These earlier avian studies were concerned with species diversity and population densities of breeding populations. One early study took a cursory look at wintering riparian birds (Johnson and Douglas 1972) and another more detailed analysis was made of the importance of wet riparian systems as migratory corridors and stopover habitat for transients (Stevens et al. 1977). A later analysis of the importance of the riparian zone to the lowland breeding avifauna of the southwestern United States also treated only wet riparian habitats (Johnson et al. 1977). Although there has been a thorough documentation of the loss of wet riparian ecosystems due to water projects and agricultural and urban development (Johnson and Carothers 1982), there has been no similar quantification of the loss of dry riparian habitat. This paper discusses a pilot project designed to quantify the high value of desert washes and arroyos as avian habitat.

## STUDY AREA AND METHODS

The vegetation along dry desert watercourse has been recognized as important habitat for birds for several decades (Hensley 1954). Lowe (1961, 1964) first delineated and defined these "desert riparian" ecosystems and further discussed and

classified the vegetation associated with these wash systems (Lowe and Brown 1973, Brown et al. 1979).

In 1980 we began avian investigations at Organ Pipe Cactus National Monument in the same region where Hensley (1954) had conducted his earlier studies. We are measuring species distribution and abundance of birds in various habitats during the different seasons of the year. Dry watercourses and their attendant xeroriparian vegetation often constitute almost 10% of the habitat of an area<sup>3</sup>. This is especially noticeable for 1st, 2nd, and 3rd order washes in desert foothills (Johnson et al. 1984). Our colleagues and other arid lands ecologists generally agree that birds and other vertebrates are apparently much more common along these well-vegetated washes. However, the only definitive papers we find for the North American deserts which address this issue are by Raitt and Maze (1968) for the Chihuahuan Desert, and Austin (1970) for the Mohave Desert. Both of these papers, however, give population densities only for the breeding season. Therefore, we have established methodology for comparing species diversity and population densities along these desert washes during all seasons and for comparing these data to the same information for nearby upland plots of equal size. The width of the xeroriparian plot (channel plus riparian habitat on both sides) varies from wash to wash, but the paired xeroriparian and upland plots in each instance are of equal size. Plot length depends on several factors including amount of stream-course braiding, density of riparian vegetation and negotiability of the wash. Severe stream braiding in large wash systems often causes problems in censusing. These problems are related to total width of the wash system and relative amount of vegetation to channel width (e.g., a single channel with a single band of riparian vegetation on each side vs. a multi-channeled wash with a reticulum of riparian vegetation). A single investigator, for

---

<sup>1</sup>Paper presented at the First North American Riparian Conference, Tucson, Arizona, April 16-18, 1985.

<sup>2</sup>R. R. Johnson and Lois T. Haight are with the National Park Service and School of Renewable Natural Resources, University of Arizona, Tucson, AZ.

<sup>3</sup>Warren, Peter L. 1985. Personal conversation. Office of Arid Lands Studies, University of Arizona, Tucson, Ariz.



example, can census a half kilometer plot in a single-channeled, third order wash in less than an hour while a braided wash of similar size and order may require a similar amount of time by each of three or four investigators because of the greater width of the wash and the associated dense vegetation. Denser vegetation requires more census time because of decreased visibility and, generally, larger numbers of birds. Dense vegetation in the wash channel, large rocks, and deep sand all increase the difficulty of walking a census "line."

Upland plots were selected far enough from xeroriparian plots to minimize movement of birds between each xeroriparian and matched upland plot. This is especially important for breeding bird censuses where one is trying to determine territorial pairs. By sitting on a nearby hill or the highest part of the upland plot for an hour or two in the

morning (and, if possible, off and on throughout the day) one can check the frequency of movement of birds between paired plots. Censuses should be run on a minimum of two days in a row, reversing the census order for riparian and upland plots from the first to the second day.

The time of day for censusing varies greatly, depending on season, local weather, and avian activity. Censusing generally begins at sunrise. During the breeding season, however, censusing generally begins as soon as light is sufficient to allow the location and identification of birds. Some species, e.g., the Brown Towhee (Pipilo fuscus), sing even before light and may cease at sunup. By contrast, we often postpone winter censusing for an hour or more after sunrise, especially for a canyon or a heavily vegetated wash that remains shaded and cool. In such situations the census taker(s) can

Table 1.--Randomly selected sample winter census from paired plots in southwestern Arizona's Arizona Upland subdivision of the Sonoran Desert.

Paired plots = 500 by 60 m in Alamo Wash, Ajo Mountains and Alamo Canyon Upland, Organ Pipe Cactus National Monument			
Weather conditions: Still, Clear		R. Roy Johnson	
30 December 1981, 0825 to 0925 h			
Common name <sup>1</sup>	Scientific name	Number of individuals	
		Xeroriparian <sup>2</sup> plot	Upland <sup>3</sup> plot
Common (Gilded Flicker)	<u>Colaptes auratus mearnsi</u>	1	
Gila Woodpecker	<u>Melanerpes uropygialis</u>	4	
Ladder-backed Woodpecker	<u>Picoides scalaris</u>	1	
Verdin	<u>Auriparus flaviceps</u>	2	
Rock Wren	<u>Salpinctes obsoletus</u>	1	
Cactus Wren	<u>Campylorhynchus brunneicapillus</u>	3	
Black-tailed Gnatcatcher	<u>Polioptila melanura</u>	3	
Ruby-crowned Kinglet	<u>Regulus calendula</u>	2	
Curve-billed Thrasher	<u>Toxostoma curvirostre</u>	1	
Crissal Thrasher	<u>Toxostoma dorsale</u>	1	
Phainopepla	<u>Phainopepla nitens</u>	6 males, 6 females	
Black-throated Sparrow	<u>Amphispiza bilineata</u>	9	
Brown Towhee	<u>Pipilo fuscus</u>	4	
Dark-eyed Junco	<u>Junco hyemalis</u>	8	
White-crowned Sparrow	<u>Zonotrichia leucophrys</u>	19	
House Finch	<u>Carpodacus mexicanus</u>	2	
Thrasher sp.?	<u>Toxostoma sp.?</u>	2	
	Individuals (incl. 2 unidentified thrashers)	75	0
	Species	16	0

<sup>1</sup>After A.O.U. Checklist, Sixth edition (American Ornithologists' Union, 1983).

<sup>2</sup>Predominant vegetation of Prosopis velutina, Lycium spp., Ambrosia ambrosioides, Sapium biloculare, Cercidium floridum.

<sup>3</sup>Predominant vegetation of Cereus giganteus, C. thurberi, Opuntia fulgida, Ambrosia deltoidea, Larrea, Cercidium microphyllum.

Table 2.--Randomly selected sample winter census from paired plots in northwestern Sonora's Lower Colorado subdivision of the Sonoran Desert.

---

Paired plots = 500 by 60 m in Papago Wash, Pinacate Area,  
Sonora, Mexico and Papago Tanks Upland

R. Roy Johnson  
31 December 1981, 9845 to 0930 h

Common name <sup>1</sup>	Scientific name	Number of individuals	
		Xeroriparian <sup>2</sup> plot	Upland <sup>3</sup> plot
Mourning Dove	<u>Zenaida macroura</u>	1	
Ladder-backed Woodpecker	<u>Picoides scalaris</u>	1	
Verdin	<u>Auriparus flaviceps</u>	6	
Black-tailed Gnatcatcher	<u>Poliophtila melanura</u>	5	
Crissal Thrasher	<u>Toxostoma dorsale</u>	1	
Phainopepla	<u>Phainopepla nitens</u>	9 males ,	5 females
Ruby-crowned Kinglet	<u>Regulus calendula</u>	1	
Yellow-rumped Warbler	<u>Dendroica coronata</u>	1	
House Finch	<u>Carpodacus mexicanus</u>	2	
	Individuals	32	0
	Species	9	0

---

<sup>1</sup>After A.O.U. Checklist, Sixth edition (American Ornithologists' Union, 1983).

<sup>2</sup>Predominant vegetation of Olneya, Cercidium floridum, Prosopis, Acacia gregii, Lycium, Hyptis emoryi, Phoradendron californicum.

<sup>3</sup>Predominant vegetation of Larrea, Ambrosia dumosa.

begin the census as soon as avian activity begins. This requires being on the plot at sunrise to monitor activity. Because of open terrain and scant vegetation, upland plots can nearly always be censused by a single observer. Direct counts are conducted as the census taker traverses the plot along a median "line." Heavily wooded washes often need two observers, one on each side of the channel or one in the bottom and one walking parallel on an overlooking hill or bank. In such cases, upland counts are also conducted by the same two observers for purposes of standardization. Horned Owls (Bubo virginianus), Western Screech Owls (Otus kennicottii), Ferruginous Pygmy-Owls (Glaucidium brasilianum), and Elf Owls (Micrathene whitneyi) are all active during crepuscular hours, at dusk and/or dawn, and present a special censusing problem (Johnson et al. 1981).

#### DISCUSSION, CONCLUSIONS, AND SUMMARY

Paired strip transects were established for comparing avian populations in xeroriparian habitat (common along dry desert watercourses) with those populations in surrounding desert upland habitat. From 1980-1985 these plots were censused for avian species diversity and population densities in the Mohave Desert, Chihuahuan Desert, and subdivisions of the Sonoran Desert (Shreve 1941). We had hypothesized that dry riparian habitats should be affected by the same factors which result in greater avian diversity and densities in wet riparian ecosystems

compared to adjacent uplands. On rare occasions we have also observed high avian use of desert upland habitats during seasons other than summer. Such rare observations of exceptional upland use have included hundreds of White-crowned Sparrows in creosotebush flats near Phoenix, Arizona in winter. In spring we have recorded flights of warblers in the desert uplands near Phoenix (especially Wilsons, Townsend's, and Yellow-rumped Warblers) as well as sparrows in creosotebush-microphyll desert near Tucson and Phoenix (mostly Black-chinned, Brewer's, Chipping, and White-crowned Sparrows).

Xeroriparian plots were established in the Arizona Upland subdivision of the Sonoran Desert at Blue Point Cottonwoods (Johnson and Simpson 1971), Saguaro National Monument near Tucson, and Organ Pipe Cactus National Monument (table 1) on the U.S.-Mexican boundary. In addition we established plots in the Pinacate lava fields of the Lower Colorado subdivision of the Sonoran Desert in northwestern Sonora, Mexico (table 2). Several plots were studied in the Central Gulf Coast of Sonora, Baja California, and Baja California Sur as well as the Vizcaino subdivision of the Sonoran Desert in Baja California (table 3). Sample plots were run in the Plains of Sonora, Foothills of Sonora, and Magdalena subdivision of the Sonoran Desert in northern Mexico. Although a complete analysis by season for the desert regions is currently underway, the purpose of this report is to demonstrate our findings regarding the high relative value of xeroriparian ecosystems as avian habitat. The tables in this paper present the

results of randomly selected censuses from three of the seven subdivisions of the Sonoran Desert in which we worked. Similar information has been provided elsewhere for the Chihuahuan Desert (Johnson and Haight, in press).

Censusing in all desert subdivisions--extensively in some, preliminarily in others--and a wide variety of vegetation types has produced similar results--species diversity and/or population densities of approximately five to ten times that of identical plots in the surrounding uplands--with one exception. Plots censused during migration in March 1981, near Punta Prieta, Baja California produced similar results for xeroriparian and upland plots. This is a particularly densely vegetated section of the Vizcaino Desert with tree species consisting of

boojums (Fouquieria columnaris) and cardones (Cereus pringeli) and numerous shrubs (e.g., Viscainoa, Opuntia molesta, Ambrosia spp., Simmondsia, and others). Large numbers of Fringillids and other species were moving through the hillside vegetation as well as along the denser streamside vegetation.

Our data demonstrate a much greater avian use of xeroriparian ecosystems when compared with upland ecosystems during all seasons in most of the subdivisions and the vegetation types in which we worked in the Sonoran Desert. Preliminary investigations indicate that the same is true for most seasons in other subdivisions of the Sonoran Desert as well as for the Chihuahuan and Mohave deserts. Additional studies are now in progress to further quantify avian activities in xeroriparian ecosystems of the North American deserts.

Table 3.--Randomly selected sample winter census from paired plots in the Viscaino subdivision of the Sonoran Desert.

Paired plots = 800 by 30 m in Catavina Arroyo, Baja California and Catavina Upland			
R. Roy Johnson and Lois T. Haight			
27 December 1983, 0900 to 0940 h			
Common name <sup>1</sup>	Scientific name	Number of individuals	
		Xeroriparian <sup>2</sup> plot	Upland <sup>3</sup> plot
Verdin	<u>Auriparus flaviceps</u>	1	
Rock Wren	<u>Salpinctes obsoletus</u>	1	
Black-tailed Gnatcatcher	<u>Polioptila melanura</u>	2	
Loggerhead Shrike	<u>Lanius ludovicianus</u>	2	No census
Brewer's Sparrow	<u>Spizella breweri</u>	2	
White-crowned Sparrow	<u>Zonotrichia leucophrys</u>	13	
House Finch	<u>Carpodacus Mexicanus</u>	2 males + 2	
	Individuals	25	
	Species	7	
28 December 1983, 0830 to 0945 h			
Costa's (?) Hummingbird	<u>Calypte costae</u>	Pair courting	
Black-tailed Gnatcatcher	<u>Polioptila melanura</u>	5	
Gray Thrasher	<u>Toxostoma cinereum</u>	3 + 2 singing	
Phainopepla	<u>Phainopepla nitens</u>	Male	
Green-tailed Towhee	<u>Pipilo chlorurus</u>	1	
Black-throated Sparrow	<u>Amphispiza bilineata</u>	1 singing	
White-crowned Sparrow	<u>Zonotrichia leucophrys</u>	18	
	Individuals	33	0
	Species	7	0

<sup>1</sup>After A.O.U. Checklist, Sixth edition (American Ornithologists' Union 1983).

<sup>2</sup>Predominant vegetation of Prosopis, Ephedra, Lycium, Acacia gregii.

<sup>3</sup>Predominant vegetation of Larrea, Ambrosia cf. dumosa, Agave.

LITERATURE CITED

- Austin, G. T. 1970. Breeding birds of the desert riparian habitat in southern Nevada. *Condor* 72:431-436.
- Brown, D. E., C. H. Lowe, and C. P. Pase. 1979. A digitized classification system for the biotic communities of North America, with community (Series) and association examples for the Southwest. *J. Arizona-Nevada Acad. Sci.* 14 (Suppl.1):1-16.
- Carothers, S. W., and R. R. Johnson. 1971. A summary of the Verde Valley breeding bird survey, 1970. *Ariz. Game and Fish Dept. Completion Report FW 16-10:46-64.*
- Carothers, S. W., R. R. Johnson, and W. W. Aitchison. 1974. Population structures and social organization of southwestern riparian birds. *Amer. Zool.* 14:97-108.
- Hensley, M. M. 1954. Ecological relations of the breeding bird population of the desert biome in Arizona. *Ecol. Monogr.* 24:185-207.
- Johnson, R. R. 1971. Tree removal along southwestern rivers and effects on associated organisms. *Amer. Phil. Soc. Yrbk.* 1970:321-322.
- Johnson, R. R., B. T. Brown, L. T. Haight, and J. M. Simpson. 1981. Playback recordings as a special avian censusing technique. *Studies in Avian Biology* No. 6:68-75.
- Johnson, R. R., and S. W. Carothers. 1982. Riparian habitats and recreation: Interrelationships and impacts in the Southwest and Rocky Mountain region. *Eisenhower Cons. Bull.* No. 12, USDA For. Serv. Rocky Mtn. For. and Range Exp. Stn., Ft. Collins, Colo. 31 p.
- Johnson, R. R., and C. L. Douglas. 1972. Highways and their impact on the wildlife of the pinyon-juniper-oak woodland in north-central Arizona. *Ariz. Highway Dept., Phoenix.* 149 p.
- Johnson, R. R., and L. T. Haight. In Press. Avian use of xeroriparian systems in the Big Bend region, Texas. *Proceedings 2nd Symposium on Chihuahuan Desert, C.D. Res. Inst., Alpine, Tex.*
- Johnson, R. R., L. T. Haight, and J. M. Simpson. 1977. Endangered species vs. endangered habitat. p. 68-79 *In* *Proceedings of symposium on importance, preservation, and management of the riparian habitat.* USDA For. Serv. Gen. Tech. Rpt. RM-43, Rocky Mtn. For. and Range Expt. Stn., Ft. Collins, Colo. 217 p.
- Johnson, R. R., and J. M. Simpson. 1971. Important birds from Blue Point Cottonwoods, Maricopa County, Arizona. *Condor* 73:379-380.
- Lowe, C. H., Jr. 1961. Biotic communities in the sub-Mogollon region of the inland Southwest. *J. Ariz. Acad. Sci.* 2(1):40-49.
- Lowe, C. H. 1964. Arizona landscapes and habitat. p. 1-132 *In* C. H. Lowe (Ed.), *The vertebrates of Arizona.* University of Arizona Press, Tucson, Ariz. 270 p.
- Lowe, C. H., and D. G. Brown. 1973. The natural vegetation of Arizona. *Arizona Resources Information System Cooperative Publication.* No.2. 53 p.
- Raitt, R. J., and R. L. Maze. 1968. Densities and species composition of breeding birds of a creosotebush community in southern New Mexico. *Condor* 70:193-205.
- Shreve, F. 1951. *Vegetation of the Sonoran Desert.* Carnegie Inst. Wash. Publ. 591. 192 p.; maps and photos.
- Stevens, L., B. T. Brown, J. M. Simpson, and R. R. Johnson. 1977. The importance of riparian habitats to migrating birds. p. 156-164 *In* *Proceedings of symposium on importance, preservation, and management of the riparian habitat.* USDA For. Serv. Gen. Tech. Rpt. RM-43, Rocky Mtn. For. and Range Exp. Stn., Ft. Collins, Colo. 217 p.

# Comparison of Three Micrometeorological Methods to Calculate Evapotranspiration in Owens Valley California<sup>1</sup>

Lowell F. W. Duell, Jr., and Diane M. Nork<sup>2</sup>

Abstract.--Using the Bowen ratio/energy-budget, eddy-correlation, and Penman combination methods, 24-hour evapotranspiration values, in millimeters per day, were 6.1, 6.0, and 21.7 for a salt grass site in May 1984; 1.2, 2.0, and 12.3 for a greasewood site in June 1984; and 1.6, 2.2, and 10.4 for a rabbitbrush site in July 1984.

## INTRODUCTION

The U.S. Geological Survey, in cooperation with the city of Los Angeles and Inyo County, has undertaken a ground-water study to quantify the fluxes of ground water in the aquifer system of Owens Valley, Calif. In Owens Valley, evapotranspiration (ET)--plant transpiration and evaporation from the soil surface--is one of the largest fluxes out of the ground-water system and the least understood. Because of the valley's semiarid to arid conditions, more than one method of calculating ET was required to test the accuracy of results and the applicability of each method. The study uses three methods to calculate ET: Bowen ratio/energy-budget method, eddy-correlation method, and Penman combination method. This paper presents the equations and selected results for each method.

## STUDY AREA

Owens Valley is in the eastern part of central California, bounded by the Sierra Nevada on the west and the White and Inyo Mountains on the east. The long, narrow valley comprises 8,500 square kilometers. The valley floor is about 1,200 meters above sea level, and the mountains rise more than 4,300 meters above sea level. The study area (fig. 1) encompasses about 1,300 square kilometers.

The climate in Owens Valley is semiarid to arid. Annual precipitation ranges from 100 to 150 millimeters and the phreatophyte growing season is from March to September. Soils range from sandy to loamy and depths to ground water range from land surface to 5 meters below land surface depending on site location.

<sup>1</sup>Paper presented at the North American Riparian Conference [University of Arizona, Tucson, AZ, April 16-18, 1985].

<sup>2</sup>Lowell F. W. Duell, Jr., and Diane M. Nork are Hydrologists, U.S. Geological Survey, WRD, San Diego, CA.

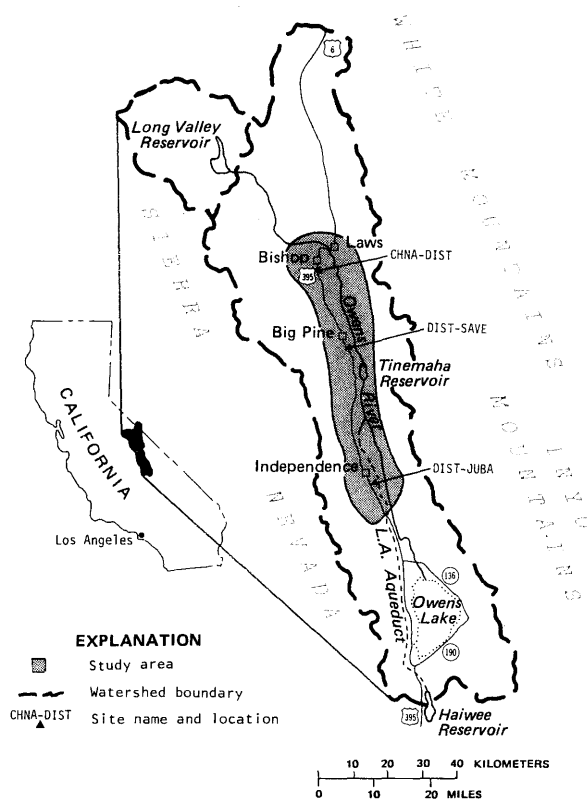

Figure 1.--Location of study area.

## DESCRIPTION OF METHODS AND SITE LOCATION

Seven locations were selected to calculate ET rates in Owens Valley. Three locations are continuous-record sites that have semipermanent meteorological instrumentation. At these sites, the Bowen ratio/energy-budget method is used for periods of up to 2 weeks per month during the growing season. During plant dormancy and times when the Bowen ratio/energy-budget is not used, instrumentation is changed to use the Penman combination method to calculate potential ET. The eddy-correlation method also is used at these sites for comparative and correlative purposes. The other four locations are partial-record sites

where ET is calculated only by the mobile eddy-correlation instruments with data taken 1 to 3 days each month. Additional results of the eddy-correlation method are in Duell (1985).

The three continuous-record sites are identified by abbreviations of the codominant phreatophyte species that are within each site (fig. 1). The common plant names, plant genus and species, and species abbreviations used for site description are as follows:

Salt Grass--*Distichlis stricta* var. *stricta* (DIST)  
 Greasewood--*Sarcobatus vermiculatus* (SAVE)  
 Rubber Rabbitbrush--*Chrysothamnus nauseosus* (CHNA)  
 Baltic Rush--*Juncus balticus* (JUBA)

At the sites, DIST-JUBA, DIST-SAVE, and CHNA-DIST, ET rates were calculated on May 22-23, June 6-7, and July 14-15, 1984. All results presented in this paper are from simultaneous use of all three methods in the same 24-hour period for each location site.

#### INSTRUMENTATION

In each of the three methods, the energy budget is the necessary calculation, however, instrumentation varies with each method. The Bowen ratio/energy-budget instrumentation consists of a net radiometer, a thermopile-type soil-heat-flux plate, a pair of ventilated wet- and dry-bulb psychrometers, and a micrologger that records data on cassette tape. The psychrometers--mounted on a pulley system on a 2-meter tall mast--sense temperatures and vapor densities at the top of the plant canopy (1 meter) and 1 meter higher than the plant canopy. In order to prevent sensor bias, the positions of the psychrometers are reversed every 15 minutes, and data averages are accumulated every 30 minutes. The mobile eddy-correlation instrumentation includes a Lyman-alpha hygrometer, a sonic anemometer, a fine wire thermocouple, and a data logger equipped with covariance software; additional components of the energy budget are calculated with a net radiometer and five soil-heat-flux plates. The Penman combination instrumentation consists of net radiometer, a soil-heat-flux plate, a cup anemometer, a solid-state relative humidity probe, and a data logger. A more complete description of all instrumentation is in Simpson and Duell (1984).

#### DEVELOPMENT OF GOVERNING EQUATIONS

Because ET is a significant component of the energy budget, theoretically, the ET rate may be calculated by estimating all of the other elements in the energy-budget equations. With photosynthesis, respiration, and heat storage in the crop canopy neglected, the equation for the energy budget at the earth's surface can be expressed as

$$R_n - G - SHF - \lambda E = 0 \quad (1)$$

where

$R_n$  is net radiation, in watts per square meter;

$G$  is rate of heat storage in the soil or water, in watts per square meter;  
 $SHF$  is sensible heat flux, in watts per square meter;  
 $\lambda$  is latent heat of vaporization, equal to 2,450 Joules per gram at 20°C; and  
 $E$  is quantity of water evaporated, in grams per square meter.

#### Use of the Governing Equations

##### Bowen Ratio/Energy-Budget Method

In determining the components of an energy budget, net radiation and soil heat storage can be measured without much difficulty. Sensible and latent heat fluxes depend on atmospheric fluctuations and are somewhat more difficult to determine. The Bowen ratio partitions the energy budget between sensible and latent heat. Assuming the eddy diffusivities for heat and vapor transport are equal, rearranging equation (1) leads to

$$\lambda E = (R_n - G) / (1 + SHF / \lambda E), \quad (2)$$

$$B = SHF / \lambda E, \quad (3)$$

where

$\lambda E$  is latent heat flux, in watts per square meter; and

$B$  is Bowen ratio, dimensionless (Bowen, 1926).

Other elements are the same as defined in equation (1). The Bowen ratio ( $B$ ) can be determined by

$$B = \gamma \Delta T / \Delta \rho v \quad (4)$$

where

$\gamma$  is psychrometer constant, in grams per cubic meter per degree Celsius;

$T$  is air temperature in degrees Celsius;  
 $\Delta T$  is difference in air temperature at two heights, in degrees Celsius;

$\rho v$  is vapor density, in grams per cubic meter; and

$\Delta \rho v$  is difference in vapor density at two heights, in grams per cubic meter.

The psychrometer constant ( $\gamma$ ) can be calculated by

$$\gamma = \rho_a C_p / \lambda \quad (5)$$

where

$\rho_a$  is air density, equal to

$$1204 \left( \frac{\text{station barometric pressure, in millibars}}{\text{sea level barometric pressure, in millibars}} \right) \quad (6)$$

at 20°C in grams per cubic meter;

$C_p$  is heat capacity of air, equal to 1.01 Joules per gram per degree Celsius; and  
 $\lambda$  is same as defined in equation (1).

Vapor density ( $\rho v$ ) can be determined by

$$\rho v = \rho v_s - \gamma (T - T_w) \quad (7)$$

where

$\rho v_s$  is saturated vapor density, in grams per cubic meter; and

$T_w$  is wet bulb temperature, in degrees Celsius.

Other elements are as defined in equation (4). Saturated vapor density (Pvs) can be calculated by

$$Pvs = \frac{\exp\left\{52.57633 - \frac{6790.4985}{Tw+273.16} - 5.02808 \ln(Tw+273.16)\right\}}{[0.000462(Tw+273.16)]} \quad (8)$$

where

Tw is the same as defined in equation (7).

#### Eddy-Correlation Method

Swinbank (1951) proposed an eddy-correlation method to calculate the vertical flux of heat and water vapor that is transported by fluctuations, or eddies, in the atmosphere. For the eddy-correlation method, sensible and latent heat fluxes are calculated independent of other energy budget components. Sensible heat flux is calculated from the covariance of wind and temperature flux, and latent heat flux is directly calculated by the covariance of vapor and wind flux. These two components, theoretically, should equal the energy budget; however, in field conditions the components failure to do so results in the need to calculate the difference, or closure, between the fluxes and the energy budget. The percent closure of the energy budget is calculated by

$$\text{Energy-budget closure} = \frac{(\lambda E + SHF)}{R_n - G} 100 \quad (9)$$

The elements are the same as defined in equation (1). The energy-budget residual is more accurate than measurements of direct vapor flux based on regression analysis of the energy-budget closure, calibration problems associated with the direct-vapor flux instrument, manufacturers' recommendations, and field tests. Therefore, the latent heat flux is calculated as a residual of the other energy-budget components by the following equation

$$\lambda E = R_n - G - SHF \quad (10)$$

Elements are defined in equation (1).

#### Penman Combination Method

Many equations are available for estimating potential ET from climatic data, and of these, the Penman combination equation is used for this study. The original Penman equation (Penman, 1956) for calculating potential ET is based on the assumptions that water is in plentiful supply, the plant is of uniform height, and canopy resistance to heat and vapor transfer to the atmosphere are equal. Based on field conditions, the original equation was altered to meet conditions in Owens Valley. The equation used for the Penman combination method (Campbell, 1977) is

$$\lambda E_p = \frac{S}{S+\gamma} (R_n - G) + \frac{\gamma}{S+\gamma} (\lambda/rH)(\rho_{vs} - \rho_v) \quad (11)$$

where

$\lambda E_p$  is potential latent heat flux, in watts per square meters;

S is slope of the saturated vapor density, in grams per cubic meter per degree Celsius;

rH is resistance to heat transport, in seconds per meter; and

Z is instrument height, in meters.

Other elements are the same as defined in equations (1), (4), and (7). The slope of the saturated vapor density (S) can be calculated by the results of a cubic regression on data presented in Campbell (1977) which gives the following equation

$$S = 0.337569 + 0.02067T + 0.00427T^2 + 0.000011T^3 \quad (12)$$

where

T is the same as defined in equation (4). The resistance to heat transport (rH) can be calculated by

$$rH = \frac{\ln(Z - d + Zh) \ln(Z - d + Zm)}{Zh Zm k^2 u} \quad (13)$$

where

h is (average crop height) x (vegetation percent cover), in meters;

d is  $0.979 \log h - 0.154$ , in meters (Stanhill, 1969);

Zm is  $0.13 h$ , in meters;

Zh is  $0.2 Zm$ , in meters; and

k is von Karman's constant equal to 0.4, dimensionless; and

u is mean wind speed at height Z, in meters per second.

Other elements are the same as defined in equation (11).

## RESULTS AND DISCUSSION

Selected results from the three methods for each site are given in table 1. In order to minimize the error associated with each component of the energy budget--in particular the change in energy storage above the point measurement of soil heat flux--all components used for the calculation of values (presented in table 1) are mean weighted totals for each  $\frac{1}{2}$  or 1-hour period of measurement integrated during 24 hours.

Calculations of Bowen ratio values varied considerably throughout a 24-hour period, particularly during sunrise and sunset. Fuchs and Tanner (1970), Black and McNaughton (1971), Grant (1975), and Gay (1980) have recognized such discrepancies, and current data usually include only the daylight hours. In general, data collected from sunset to sunrise may be considered unimportant because there is little energy available to cause evaporation, and the energy that is available produces sensible heat loss. Bowen ratio fluctuations throughout the day may be attributed to errors in temperature and vapor-density measurements or instrumentation malfunction.

The eddy-correlation method allows for the direct determination of sensible and latent heat fluxes independent of the energy budget. In this study, the latent heat flux also is calculated as a residual of the other energy-budget components. Calculating latent heat flux as an energy-budget

Table 1.--Comparison of evapotranspiration rates and site and micrometeorological characteristics between sites.

[Site characteristics: Vegetation cover from City of Los Angeles, Department of Water and Power (written commun., 1984); Average plant height from D. C. Warren, Inyo County (oral commun., 1984)]

	DIST-JUBA	DIST-SAVE	CHNA-DIST
<u>Evapotranspiration rate</u>			
Bowen ratio/energy-budget method-----mm/d--	6.1	1.2	1.6
Eddy-correlation method			
Residual-----mm/d--	6.0	2.0	2.2
Direct measurement-----mm/d--	4.0	.6	.3
Penman combination method-----mm/d--	21.7	12.3	10.4
<u>Site characteristics</u>			
Vegetation cover-----percent--	70.0	22.0	50.0
Average plant height-----m--	.25	.4	.5
<u>Micrometeorological characteristics</u>			
Average sensible heat flux			
Bowen ratio/energy-budget method----W/m <sup>2</sup> --	12.0	122.0	75.0
Eddy-correlation method-----W/m <sup>2</sup> --	3.0	88.0	65.0
Average net radiation-----W/m <sup>2</sup> --	200.0	148.0	133.0
Average soil heat flux-----W/m <sup>2</sup> --	27.2	2.5	6.5
Average wind speed-----m/s--	4.8	2.8	2.6
Average vapor density deficit-----g/m <sup>3</sup> --	22.0	15.2	20.8

residual (equation 10) eliminates some of the error associated with the direct determination of latent heat flux by the eddy-correlation instrumentation. At the DIST-SAVE and CHNA-DIST sites, ET rates calculated by the eddy-correlation method are larger than the ET rates calculated by the Bowen ratio/energy-budget method. In these two cases, large ET rates are probably due to sensible-heat-flux values being too low as determined by the eddy-correlation method which indicates that some error can be attributed to this measurement. Thus, the residual ET values indicate an upper limit to the flux values rather than the absolute value. The error is small for the DIST-JUBA site because total sensible heat flux was small. At the other sites, sensible heat flux was dominant so even a small percentage error in sensible-heat-flux calculations can produce a percentage error in latent-heat-flux calculations (E. P. Weeks, U.S. Geological Survey, written commun., 1985). This study indicates that errors associated with the calculation of sensible heat flux by the eddy-correlation instrumentation are less than those associated with the direct latent-heat-flux determination, thus indicating that ET rates resulted from energy-budget residual latent-heat-flux values may be more accurate than those resulting from latent-heat-flux values determined directly by the eddy-correlation instrumentation. The residual latent-heat-flux values (maximum rate)

and the determined latent-heat-flux values (minimum rate) are in table 1.

Large potential ET rates using the Penman combination method at the DIST-JUBA site may be due to wind speeds that ranged from 2.5 to 8.7 meters per second. Error associated with vapor-density-deficit calculation also could be responsible for the large potential ET values; however, variance analysis of the vapor-density deficit determined with the relative humidity probe, versus that calculated from psychrometric data, indicated no significant difference between the two means of data collection. This study indicated that it was necessary to adjust the Penman equation for resistance to heat transfer (equation 13) in order to account for the lack of complete vegetation cover at the sites. Thus, altering resistance to heat transport and the elements of the wind function in the Penman combination method had a significant effect on the calculated potential ET rates. It also seems likely that in the semiarid to arid environment of Owens Valley, incomplete cover and the nature of the vegetation combine to make the resistance to vapor transport from the canopy to the air considerably greater than resistance to heat transport (E. P. Weeks, U.S. Geological Survey, written commun., 1985). In this case, then, resistance to vapor transport is not equal to resistance to heat transport, which indicates that another method may be more suitable for estimating potential ET.



## CONCLUSIONS

In Owens Valley, ET accounts for the removal of a significant quantity of ground water. The valley's phreatophyte communities differ largely in species composition and percent cover, therefore, ET rates were monitored at a variety of sites. The valley's semiarid to arid conditions require the use of more than one method to calculate ET rates in order to test the applicability of each method.

Results from the Bowen ratio/energy-budget method for calculating ET rates can be both consistent and satisfactory, as well as fluctuating. Despite the fluctuating data, which needs to be adjusted to account for the sunset to sunrise hours in a 24-hour period, the Bowen ratio/energy-budget method is suitable for calculating actual ET rates in Owens Valley. ET rates calculated by the eddy-correlation method are generally larger than ET rates calculated by the Bowen ratio/energy-budget method. This difference in ET rates may indicate an upper limit to latent-heat-flux values as calculated by the eddy-correlation method; however, the results of the two methods generally agree. The eddy-correlation method presents usable results with the advantage of instrument mobility. The Penman combination method needs to be adjusted to account for physical and biological variables indigenous to Owens Valley, and does not seem to be reliable in calculating potential ET in Owens Valley at this time.

For calculating actual ET rates, results from the Bowen ratio/energy-budget and eddy-correlation methods are satisfactory and indicate the methods' suitability for continued use in the ongoing Owens Valley studies. The methods presented in this report can have applicability to similar areas in the semiarid to arid Western United States.

## REFERENCES

- Black, T. A. and K. G. McNaughton. 1971. Psychrometric apparatus for Bowen ratio determinations over forests. *Boundary-layer Meteorology*, v. 2, p. 246-254.
- Bowen, I. S. 1926. The ratio of heat losses by conduction and by evaporation from any water surface. *Phys. Rev.*, v. 27, p. 779-787.
- Campbell, G. S. 1977. An introduction to environmental biophysics. Springer-Verlag, New York, 159 p.
- Duell, L. F. W., Jr. 1985. Evapotranspiration rates from rangeland phreatophytes by the eddy-correlation method in Owens Valley, California. 17th Conference on Agricultural and Forest Meteorology. [Phoenix, AZ, May 1985] *American Meteorological Society Bulletin*, Paper A&F3.2, p. 44-47.
- Fuchs, M. R. and C. B. Tanner. 1970. Error analysis of Bowen ratios measured by differential psychrometry. *Ag. Meteorology*, v. 7, p. 329-334.
- Gay, L. W. 1980. Energy budget measurements of evaporation from bare ground and evapotranspiration from salt cedar groves in the Pecos River flood plain, New Mexico. Report to U.S. Geological Survey, WRD, Grant No. 14-08-001-G-617, 46 p.
- Grant, D. R. 1975. Comparison of evaporation measurements using different methods. *Quart. J. R. Met. Soc.*, v. 101, p. 543-550.
- Penman, H. L. 1956. Estimating evaporation. *Trans. Am. Geophys. Union*, v. 37, p. 43-50.
- Simpson, M. R. and L. F. W. Duell, Jr. 1984. Design and implementation of evapotranspiration measuring equipment for Owens Valley, California. *Ground Water Monitoring Review*, Fall, p. 155-163.
- Stanhill, G. A. 1969. A simple instrument for the field measurement of turbulent diffusion flux. *Journal of Applied Meteorology*, v. 8, p. 509-513.
- Swinbank, W. C. 1951. The measurement of vertical transfer of heat and water vapor by eddies in the lower atmosphere. *J. Meteorology*, v. 8, p. 135-145.

# A Field Assessment of Above- and Below-Ground Factors Affecting Phreatophyte Transpiration in the Owens Valley, California<sup>1</sup>

D. P. Groeneveld, D. L. Grate, P. J. Hubbard, D. S. Munk,  
P. J. Novak, B. Tillemans, D. C. Warren, and I. Yamashita<sup>2</sup>

Abstract. Factors influencing the water balance physiology and transpiration of five Great Basin shrub and grass phreatophytes are being investigated in shallow groundwater zones of the arid Owens Valley, California. Measurements of transpiration, atmospheric potential, canopy factors, root density, soil moisture and xylem potential are presented and discussed.

## INTRODUCTION

Shallow groundwater/arid climate ecosystems have received little detailed study. In an effort to gain sufficient knowledge to manage such an ecosystem, Inyo County, California and the City of Los Angeles have jointly funded a field investigation in the Owens Valley. The study is structured to determine the transpiration rates, physiology and morphology of five important plant species inhabiting shallow groundwater zones toward an ultimate management goal to preserve the shallow groundwater habitats during pumping and export of groundwater. This paper attempts to list the methods and initial results of the first of three years of field study. In essence, the study is attempting to ask both "how much do shallow groundwater plants transpire" and "how is transpiration controlled." The accumulating data base is being used to provide input and interpretive information bases for research conducted by the United States Geological Survey to determine phreatophyte survival following pumping and to model vadose zone moisture extraction by roots.

## Study Area

The Owens Valley is located in eastern California between the Sierra Nevada on the west and the White and Inyo Mountains to the east (fig. 1). The 25 to 30 km wide valley floor slopes gently from the northeast to the southwest. The study area comprises the valley floor lying between the Inyo-Mono County line and the Owens Dry Lake and ranges between 1250 m and 1160 m in elevation. The crests of the Sierra Nevada and Inyo and White Mountains rise precipitously from the valley floor to an average of 3,700 and 3,100 meters respectively.

<sup>1</sup>Paper presented at the North American Riparian Conference [Tucson, Arizona, April 16-18, 1985].

<sup>2</sup>Members of the Cooperative Vegetation Study Team, funded by Inyo County and the City of Los Angeles, Bishop, California.

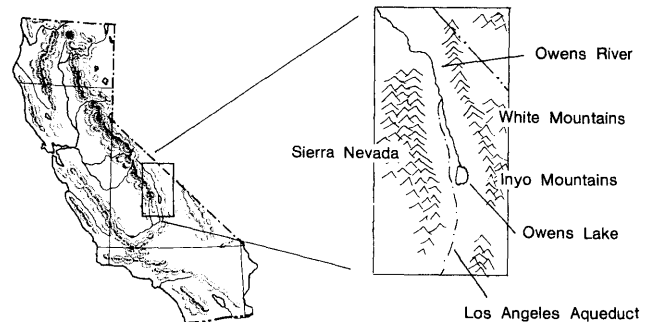

Figure 1.--Location Map of the Study Area.

The Valley floor precipitation is highly variable and averages from 10 to 15 cm depending on location. Low precipitation is augmented by copious runoff from the Sierra Nevada combining to create a unique ecology of shallow groundwater and arid climate.

## Vegetation

Five plant species are ubiquitous to shallow groundwater sites in the Owens Valley and are the subject of this study: Nevada saltbush (*Atriplex torreyi*), greasewood (*Sarcobatus vermiculatus*), rabbitbrush (*Chrysothamnus nauseosus* ssp. *viridulus*), saltgrass (*Distichlis spicata*) and alkali sacaton (*Sporobolus airoides*) (Munz and Keck 1959). These species are both phreatophytic, requiring or thriving on groundwater and halophytic, tolerating or requiring high concentrations of soil salts.

## METHODS

Ten study sites are developed to examine both above and below ground factors to determine the coupling of groundwater capillary movement and extraction by plants. Two of the sites are developed for more intensive measurement of plant response to artificially lowered water tables. A suite of data including atmospheric potential, canopy leaf area,

transpiration and soil moisture is measured at least monthly during the April through October growth cycle. These records are kept for eight grass plots and 32 individual shrubs. Cores for determining root density are taken quarterly to conform to the seasons of the year on a subsample of six grass plots and 18 shrubs.

Soil moisture content is measured periodically by neutron probe accessed through aluminum tubes fitted with welded closures. These tubes were placed as deeply as possible into the soil profile at canopy driplines of shrubs, through grass plots and into ground with vegetation cleared for 3 meters. Three master calibration curves with correlation coefficients of about 90 percent were calculated for use on all access tubes at the study sites. These curves are parallel and have intercepts which vary according to depth at 15 and 30 centimeters due to neutron escape from the soil surface. The water table surface is monitored at each site by a shallow well outfitted with a recorder to compare to the observed soil moisture responses.

Root system morphology and soil horizon are accessed by trenching to the water table with a structure emplaced to guard against collapse of the trench walls. Root systems are exposed for viewing and sampling with a pressurized stream of water from a pickup truck-mounted tank and pump.

Samples obtained in one liter volume cores to assess root density are centered at 30.5 cm. increments starting at 15.3 cm. These cores are obtained by sawtooth bit mounted on a 7.6 cm outside diameter barrel. The fine absorptive roots are separated from the soil volume by elutriation. The system uses a water stream and turbulent agitation to process eleven samples at a time. Root length estimation by a statistical method modified after Newman (1966) uses the empirical relationship between root length and the root/grid intersections counted under a binocular stereomicroscope. A set of criteria for judging "live" versus "dead" roots was adopted based upon preliminary observation.

The statistical distribution of root density is not normal (St. John and Hunt 1983). This is due to the tendency for the deciduous fine roots to be organized into cells according to proximity to the more permanent roots. The transformation  $\log(X + 1)$  suggested by Anscombe (1949) for such distributions normalizes the Owens Valley root data.

#### Plant Water Physiology

The Scholander type pressure chamber is used to assess plant moisture status by measuring xylem pressure potential (Ritchie and Hinckley 1975). The pressure chamber technique is used on five samples per experimental shrub or grass plot. Pre-dawn and mid-day measurements are collected to compare to a per plant suite of soil moisture, transpiration and stomatal conductance data.

Transpiration and stomatal conductance are measured with a null-balance porometer (Beardsell, et al. 1972) manufactured by Li-Cor, Inc., of Lincoln, Nebraska. Also obtained are time, ambient relative humidity and temperature and photosynthetically

active radiation (0.4 to 0.7  $\mu$ m wavelength) at the position of the *in situ* branches or leaves. Shrub branches are placed within a cylindrical split and hinged polycarbonate chamber for the series of measurements. Five branches per shrub are monitored through a diurnal period for statistical representation of the canopy. Leaf areas of the shrub samples are estimated for correction of transpiration and diffusive resistance data. The cuvette designed for the grasses measures only one surface at a time, so both abaxial and adaxial surfaces of the grass blades are monitored.

#### Phenology and Leaf Area

A non-destructive method was developed for the project which estimates leaf area and biomass on an experimental plant or plot by point frame (Goodall 1952). The technique uses an empirical relationship developed between leaf area and leaf biomass and a total of the interceptions of the point frame pins with leaves on the shrub canopy or grass plot. Each experimental plant is measured by this technique to follow phenology and leaf area for transpiration calculations.

#### RESULTS

The results from one year of study are presented for the intensive study site located near Warm Springs and south of Bishop in the northern Owens Valley. Pertinent observations from several other sites are included to help illustrate the ecology of the five plant species.

#### Soil Moisture

The soil at the Warm Springs site is predominantly coarse sandy loam to loamy sand textures with bulk density ranging from 1.4 g/cm<sup>3</sup> at the surface to 1.7 g/cm<sup>3</sup> at 180 cm. deep. These factors permit rapid infiltration but tend to limit soil porosity and capillary movement of water with depth. The water table naturally fluctuates with season between a high of about 150 cm. in March to a low of 180 cm. in September responding to evapotranspirative draft. Water may enter the root zones downward either by precipitation, or upward by capillarity from the water table surface. These influxes can be traced by sequential monitoring by neutron probe and through isocontouring of the volumetric soil moisture content by depth (fig. 2). The top graph in figure 2 represents the calculated volumetric soil moisture averaged for 10 shrubs, three each of Nevada saltbush and greasewood and four of the rubber rabbitbrush accessed at the canopy drip lines. Alkali sacaton and saltgrass are accessed through plots and presented in the center graph as averages. The lowermost plot represents soil moisture beneath a microsite with vegetation cleared for a radius of three meters. The water table, indicated by dotted line, was lowered by pumping in October to initiate soil moisture drainage prior to measurements of the artificially stressed system scheduled for the following summer. The capillary recharge evident in October beneath the shrubs was due to temporary breakdown of the pumping equipment.

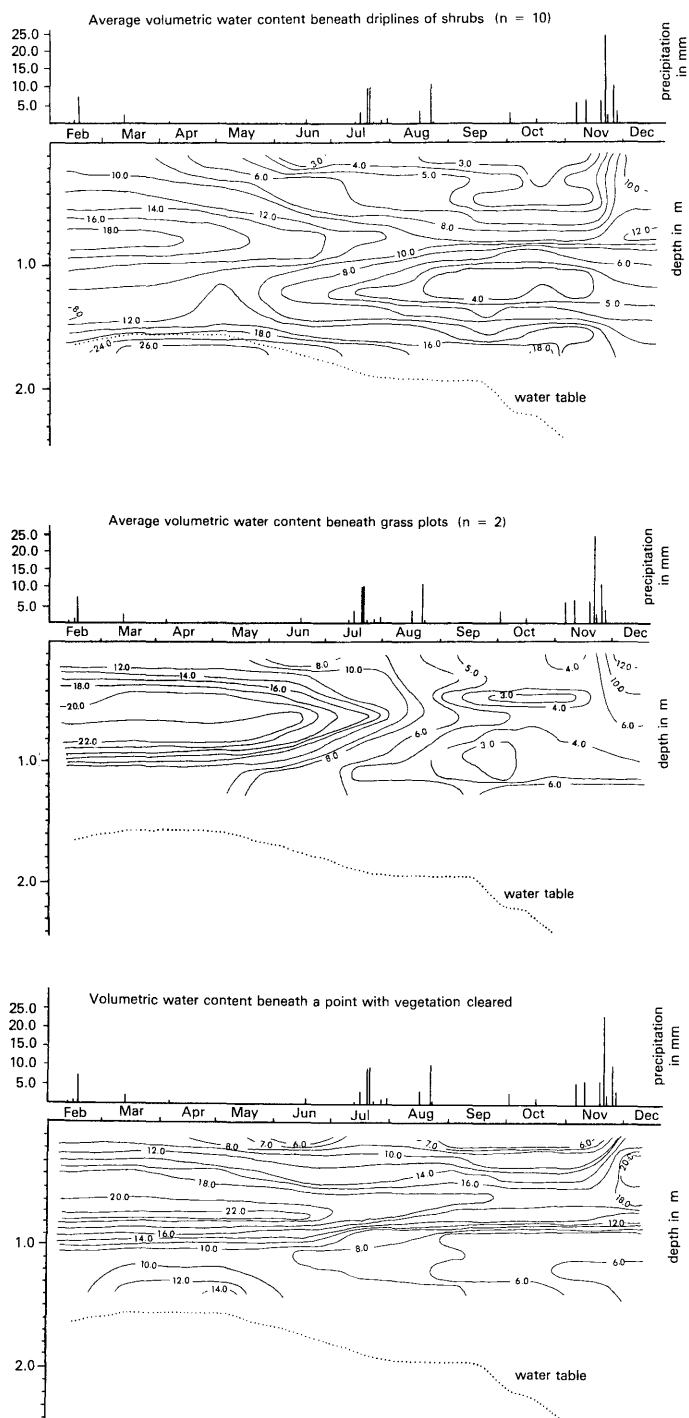

Figure 2.--Isocontours of soil moisture content under three treatments. The shrub and grass measurements are averaged.

The July and August precipitation apparently only recharged the soil profile near the surface. The November precipitation has more effectively recharged the soil. Capillary recharge from rising water tables is evident in March through May. A boundary to soil moisture movement consisting of an approximately 10 cm. horizon with weak to strong calcium carbonate and silica cementation is found at a depth of about one meter. This horizon, evi-

dent beneath the cleared micro site and the shrubs, may mark a limit for downward percolation and upward capillarity. In general, horizontal isocontours indicate that the soil moisture remains fairly constant through time and this trend can be seen until early July beneath the cleared site. Preliminary comparison of transpiration measurements on the canopies of the shrubs to the soil moisture depletion observed beneath the shrub drip lines strongly indicate that the earliest extraction occurs near each shrub. The zone of soil moisture extraction may then move outward to tap the zones between each shrub. If so, the depletion of the water content beneath the cleared site indicates extraction by more remote shrub roots.

Soil moisture changes within the profiles with vegetation cover coincides with leafing. Shrubs leaf earlier than grasses and this trend can be seen in the data. Changes in soil moisture content are evidently very low in late October conforming with grass senescence and low measured shrub transpiration rates.

Depletion of soil moisture beneath grasses occurs at a faster rate than beneath shrubs during July and August due, possibly, to extraction from the restricted soil volume explored by grasses. As a general rule, the two grasses senesce before the three shrubs which may be due to low soil moisture.

#### Rooting Relationships

Root system morphology is unique for each of the five species. Alkali sacaton is a bunch grass and saltgrass is rhizomatous. Nevada saltbush characteristically has several large lateral roots which are initiated while the shrub is in the seedling stage. Subordinate roots arise from these laterals to explore the remainder of the soil column. Greasewood roots arise from few tap roots with lateral branching near the surface. The root system of rabbitbrush is variable but tends to consist of a number of dichotomizing taproots which, in turn, give rise to lateral roots.

The highly absorptive roots of each species are probably ephemeral and function for less than one year. These roots are also quite small, on the order of 0.5 mm diameter, and are seldom visible in the soil matrix. Tetrazolium tests on dead roots extracted by hand indicated active microbial respiration which confirms that breakdown of shed roots is rapid.<sup>3</sup>

Oxygen is obviously an important factor for rooting in high groundwater sites. Excavation and pumping of trenches below the water table have shown that mature root systems of the five species are incapable of withstanding prolonged waterlogging. By contrast, histologic sections of the near surface roots of Nevada saltbush and rabbitbrush from a site flooded continuously for six months confirmed that the predominantly primary roots contained aerenchyma, cortical air spaces which decrease oxygen diffusion resistance to root tips (Coutts and Armstrong 1978). Greasewood failed to survive this flooding.

<sup>3</sup>Tetrazolium chloride provided courtesy of the California Crop Improvement Association, Davis, California.

The results of root density and statistical analysis of the transformed data indicate that root density decreases with depth, is equal among individuals or species of shrubs and varies with season. These relationships are significant above the 0.99 level. Root density versus depth describes a decay function suggestive of the relationship for nitrogen in arid ecosystems (West and Klemmedson 1978). Further analyses are concentrating on random root density under mixed species cover and on soil moisture as a determinant for rooting density. A detailed study at a site of predominantly Nevada saltbush and devoid of herbaceous cover indicated that per depth root density is equal up to ten meters from canopies.

### Transpiration and Xylem Pressure Potential

Diurnal curves of transpiration rates for the five species are roughly parabolic in response to the combined diurnal progression of atmospheric potential and photosynthetically active radiation (fig. 3). The curves of each species approach zero at sunrise and sunset which indicates that stomatal control is light sensitive.

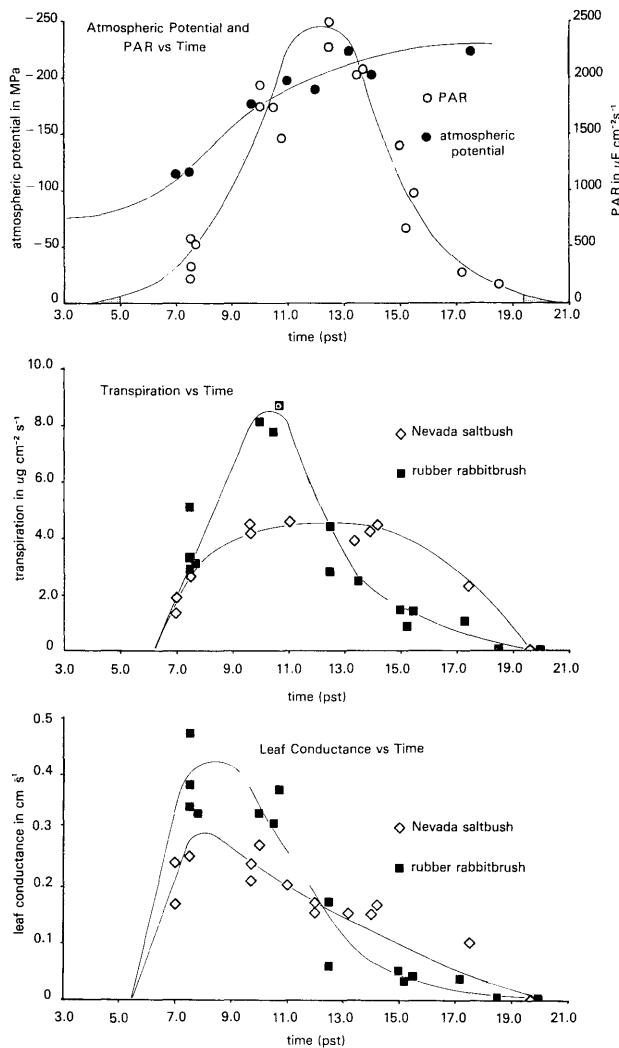

Figure 3.--Diurnal atmospheric potential, radiation (PAR) and the transpiration and stomatal responses of two of the study plants at the Warm Springs Site, 6-12 and 6-13, 1984.

The two diurnal transpiration curve shapes correlate with the photosynthetic pathway inherent for each of the five species. Photosynthetic pathways were confirmed by review of lists of plants known to use the  $C_4$  (dicarboxylic acid) pathway (Downton 1975, Raghavendra and Das 1978). Thin sections were prepared to confirm the presence of "Kranz anatomy" in leaf tissue known to indicate the  $C_4$  pathway (Huber and Sankhla 1976). Nevada saltbush, alkali sacaton and saltgrass are  $C_4$  plants and exhibit diurnal transpiration curves which are parabolic. Rubber rabbitbrush and greasewood utilize the  $C_3$  (Calvin-Benson) pathway and exhibit diurnal transpiration curves with a mid-morning high and steady decrease through the day. Leaf conductances are initially much higher in the  $C_3$  plants but decrease below rates for  $C_4$  plants by mid-afternoon.

Transpiration rates remain somewhat constant through the period between April and September and then decrease in October (fig. 4). May measurements for alkali sacaton and saltgrass show rapid transpiration rates characteristic of new growth. Rabbitbrush transpiration increased dramatically during the July rainy period. The greasewood were 75%

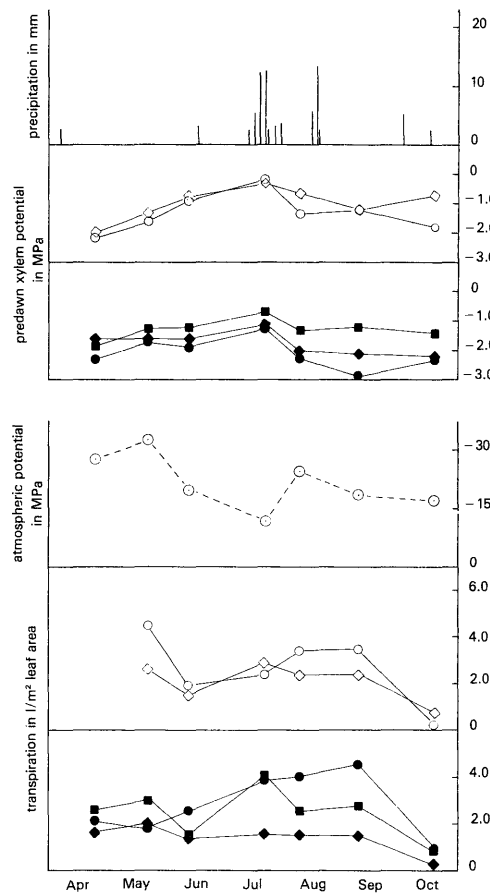

Figure 4.--Seasonal variations in weather and plant response. (○) alkali sacaton, (◇) saltgrass, (●) Nevada saltbush, (●) greasewood, (■) rubber rabbitbrush.

denuded by a blister beetle (*Epicauta normalis*)<sup>4</sup> after the July reading. The continued rise in transpiration may reflect undepleted soil moisture storage within the rhizosphere under this species.

Predawn xylem pressure potential measurements showed an increase to the July measurement and then decreased. The predawn measurements fail to show the marked seasonal depression of xylem potential characteristic of arid zone species (for example see Branson *et al.* 1976). The stable predawn xylem potentials indicate a fairly abundant supply of soil moisture in light of the transpiration rates maintained through the season. The highest potentials occur during midsummer, probably in response to the rainy period and low atmospheric potential. The shrub species have marked capacity to adjust osmotically<sup>5</sup> which may account for both the lower initial xylem potentials that occurred with relatively abundant soil moisture (fig. 2) and the reverse trend of rising transpiration during a decreasing xylem potential evident for greasewood during July through September.

#### SUMMARY

A study is being conducted in the arid Owens Valley, California to correlate transpiration by five native phreatophytes with soil, plant and atmospheric variables. Measurements of soil moisture demonstrate zones of root extraction by duration and quantity. Root density with depth varies by season but is equal per depth among individuals and species at each microsite. Transpiration measurements correlate highly with atmospheric potential and photosynthetically active radiation. Measurements of xylem pressure potential demonstrate that the shallow water tables dampen the seasonal variation typical of arid zone species.

<sup>4</sup>Derham Guiliani. 1984. Personal correspondence on file. Consulting entomologist, Big Pine, California.

<sup>5</sup>Peter Dileanis. Pressure volume curves and data on file. U.S.G.S. Botanist, Sacramento, California.

#### LITERATURE CITED

- Anscombe, F. J. 1949. The statistical analysis of insect counts based on the negative binomial distribution. *Biometrika* 5:165-173.
- Branson, F. A., R. F. Miller and I. S. McQueen. 1976. Moisture relationships in twelve northern desert shrub communities near Grand Junction, Colorado. *Ecol.* 57:1104-1124.
- Beardsell, M. F., P. G. Jarvis and B. Davidson. 1972. A null balance porometer suitable for use with leaves of many shapes. *J. Appl. Ecol.* 9:677-690.
- Coutts, M. P. and W. Armstrong. 1978. Role of oxygen transport in the tolerance of trees to waterlogging. In M.G.R. Cannell and F. T. Last (eds.) *Tree physiology and yield improvement*. Academic Press, New York.
- Downton, W. J. S. 1975. The occurrence of C<sub>4</sub> photosynthesis among plants. *Photosynthetica* 9:96-105.
- Goodall, D. W. 1952. Some considerations in the use of point quadrants for the analysis of vegetation. *Australian J. Sci. Res., Series B* 5:1-41.
- Huber, W. and N. Sankhla. 1976. C<sub>4</sub> pathway and regulation of the balance between C<sub>4</sub> and C<sub>3</sub> metabolism. In Lange, O. E., L. Kappen and E. D. Schulze (eds.) *Water and plant life* Springer-Verlag, N. Y. pp:335-357.
- Munz, P. A. and D. D. Keck. 1959. *A California flora*. 1681 p. Supplement 224 p. University of California Press, Berkeley, California.
- Newman, E. I. 1966. A method of estimating the total length of root in a sample. *J. Appl. Ecol.* 3:139-145.
- Raghavendra, A. S. and V. S. R. Das. 1978. The occurrence of C<sub>4</sub> photosynthesis: A supplementary list of C<sub>4</sub> plants reported during late 1974 - mid 1977. *Photosynthetica* 12(2):200-208.
- Ritchie, G. A. and T. M. Hinckley. 1975. The pressure chamber as an instrument for ecological research. *Adv. Ecol. Res.* 9: 165-259.
- St. John, I. V. and H. W. Hunt. 1983. Statistical treatment of VAM infection data. *Plant and Soil* 73:307-313.
- West, N. E. and J. O. Klemmedson. 1978. Structural distribution of nitrogen in desert ecosystems. In N. E. West and J. Skujins. *Nitrogen in desert ecosystems*. US/IBP Syn. Ser. 9:1-16.

# Evapotranspiration From Saltcedar Along the Lower Colorado River<sup>1</sup>

Lloyd W. Gay<sup>2</sup>

---

Abstract.--Bowen ratio ET was measured periodically in a stand of saltcedar on the Lower Colorado River during two growing seasons. Rates ranged up to 12 mm/day in July. The yearly ET totals at this site were estimated to be 1727 mm.

---

## INTRODUCTION

A variety of measurement methods have been proposed during the many years that evapotranspiration (ET) has been under study throughout the world. Most of these methods are based upon some form of the water budget. The water budget, however, is a rather insensitive method for estimating ET because of difficulties in estimating soil moisture. This becomes a more serious problem when plant roots reach the water table, as in most riparian stands.

The most promising alternative to the water budget method at this time appears to be the Bowen ratio energy budget analysis (BREB), which combines measurements of certain atmospheric variables (gradients of temperature and vapor concentration) with an assessment of available energy (net radiation and changes in stored thermal energy) to yield estimates of ET.

This paper will describe the Bowen ratio energy budget model and specialized equipment used in the field measurements, and analyze the results obtained from application to a dense stand of saltcedar (*Tamarix chinensis*, Lour.).

## BOWEN RATIO MEASUREMENTS

The BREB method is well known and described in many texts. Tanner (1960) and Spittlehouse and Black (1980) thoroughly review the method and discuss field applications. The model is based upon an energy budget analysis of the gains and losses of thermal energy at the evaporating surface. There are four major energy flows at the surface: net radiation ( $Q^*$ ), change in stored energy in soil and vegetation ( $G$ ), sensible heat

exchange between the surface and the air ( $H$ ), and latent heat which is used to evaporate water ( $LE$ ). The flows represent flux densities (energy per unit area per unit time); fluxes to the surface are positive, and away, negative. The sum of these four components in the energy budget equation will always equal zero for the time period of evaluation ( $s$ , min, day, etc.):

$$Q^* + G + H + LE = 0. \quad (1)$$

The flux densities  $Q^*$  and  $G$  are readily measured directly with a net radiometer and a soil heat flux disk, respectively. The sensible and latent heat flux densities ( $H$  and  $LE$ ) are estimated with the Bowen ratio model.

$LE$  and  $H$  can be expressed in terms of measured temperature and vapor concentration gradients if equation (1) is first divided through by  $LE$ , and then solved to yield the Bowen ratio model (Bowen, 1926),

$$LE = -(Q^* + G)/(1 + B) \quad (2)$$

with  $B$  (Bowen's ratio) given by

$$B = H/LE = AP(Kh/Ke)(dT/dz)(de/dz) \quad (3)$$

where  $AP$  is the psychrometric constant, with  $A = 0.00066/C$  and  $P$  (mb) being atmospheric pressure at the measurement site ( $AP = 0.66$  mb/C at sea level),  $Kh$  and  $Ke$  are the turbulent diffusivities for sensible energy and for vapor (the ratio  $Kh/Ke$  is assumed to equal 1.0),  $dT/dz$  is the gradient of potential temperature in the air layer just over the canopy, and  $de/dz$  is the gradient of vapor pressure.

Both gradients are measured over the same  $dz$ , which is typically 0.5 to 1 m for crops, and 1 to 3 m for forests, and located in the air layer just above the canopy or evaporating surface. The gradients are small, and precise measurements are needed to evaluate  $LE$  with equations (2, 3). Some evidence has emerged (Verma, et al., 1978) to suggest that the assumed equality of the diffusivities does not hold when the atmosphere is stable (i.e., during

---

<sup>1</sup> Paper presented at The First North American Riparian Conference. Riparian Ecosystems and Their Management: Reconciling Conflicting Uses. [University of Arizona, Tucson, April 16-18, 1985]

<sup>2</sup> Lloyd W. Gay, Professor of Watershed Management, School of Renewable Natural Resources University of Arizona, Tucson, AZ 85721

advection), but no consistent relationships have been proposed for corrections.

### The Measurement System

The generator powered BREB system used in this study has been described by Gay (1979). It consists of a set of specialized sensors, a data acquisition system and a microcomputer. The field sensors are linked by long (80 m) cables to the data acquisition and processing equipment, which operate in an air conditioned van that serves as a mobile laboratory. Data obtained in this study were sampled with a high quality digital data system (Acurex Autodata 9), and then transmitted to a microcomputer (Tektronix 4051) which transformed, analyzed and stored data in real time and printed the results.

The key sensors in the AZET system are the unique psychrometers which combine together a ceramic wetbulb element, high output resistance thermometers and a new signal circuit to yield exceptionally precise measurements of temperature and humidity (Hartman and Gay, 1981). The psychrometers are used in pairs to measure the vertical gradients of temperature and vapor concentration. The excellent performance of the psychrometers is enhanced for gradient measurements by interchanging the pair of psychrometers between readings to eliminate from the gradients any small biases that may exist between sensors.

The ET analysis is completed every 12 minutes and these values are combined to yield hourly and daily totals of ET. As a refinement, the system is usually operated with two separate sets of energy budget sensors simultaneously, and their agreement is monitored to insure that the system is functioning properly.

### Measurement Precision

The generally accepted precision of water budget ET or energy budget ET measured elsewhere is about 15 or 20 percent. The AZET system, however, has detected differences in the daily ET from two adjacent sites of as little as 0.5 percent (Osmolski and Gay, 1983), based upon hourly and daily totals from a four day series of careful measurements over irrigated alfalfa near Tucson.

Only a few tests of the method are available for riparian communities. For example, Gay and Fritschen (1979) compared 5-day mean Bowen ratio ET against values from adjacent, constant level lysimeters at the U S Bureau of Reclamation saltcedar research site on the Rio Grande near Bernardo, NM. For low, sparse stand conditions, Bowen ratio ET was 7.4 mm/day and the lysimeter values were 6.6. For denser stands, the Bowen ratio measurement was 8.8 mm/day and the lysimeter showed 9.1. The over all mean for both classes of vegetation was 8.1 mm/day for the Bowen ratio, and 7.8 for the lysimeters. The agreement was judged to be excellent for this clear, hot summer period.

## RESULTS AND DISCUSSION

### The Measurement Site

The field measurements were carried out on the floodplain of the Colorado River (425 km west of Tucson) at a site approximately 50 kilometers south and downstream of Ehrenberg, AZ, and Blythe, CA. The region is one of the driest in Arizona, with the annual rainfall at Ehrenberg totalling only 3.5 inches (Sellers and Hill, 1974). The average rainfall for the month of May is 0.02 inches, and measurable precipitation in the month of June fell only once during the 30 year record from 1942 through 1971. The dry summers are also exceptionally warm. Temperatures in excess of 115 F are frequently recorded, and the highest temperature of record is 122 F. The regulated flow of the Colorado River maintains a high, relatively constant water table beneath the floodplain, which has led to the development of extensive stands of preatophytes. Intense heat, low humidity, dense vegetation and high water tables combine to provide ideal conditions for rapid ET rates.

The BRET measurements were made on the Cibola National Wildlife Refuge near the western edge of a vast saltcedar thicket of some 10 square km in area. The height of the vegetation was about 6 m in the vicinity of the measurement site; the canopy was closed and rather uniform in this area. The site was about 3 km west of the main channel; fetch to the desert edge was about 1 km to the west and north, and about 3 km to the south and east.

The floodplain soils were sandy, with numerous pockets of coarser material laid down when the river channel meandered through the floodplain in the past. The water table depth remained nearly constant at 3.3 m during the two summers of measurement, as high runoff and storage levels upstream resulted in higher than average flows for the lower Colorado River.

### ET Totals

Measurements were obtained for periods of 2-4 days duration on each of 8 separate expeditions during the growing seasons of 1980 and 1981. The results are described in detail by Gay<sup>3</sup>, and summarized by Gay and Hartman (1982). Good data were obtained for 21 days (daytime periods of positive net radiation) and for 11 nights. The daytime water use ranged from about 2 mm/day in spring and fall, up to about 12 mm/day in midsummer, while night loss rates were quite low, ranging from as little as 0.08 mm/day up to 0.6 mm/day in midsummer. The night data were interpolated as needed to obtain 21 sets of 24-hour ET totals extending over the season.

The totals at the two masts differed by

<sup>3</sup> Gay, L. W. 1984. The Effects of Vegetation Conversion upon Water Use by Riparian Plant Communities. Research Project Completion Report (B-084-ARIZ). School of Renewable Natural Resources, Univ. Arizona, Tucson 85721.



about 5 percent on a daily and a seasonal basis. This difference remained during several runs in which the sensors were interchanged between sites, thus confirming that the difference was site related, rather than instrumental. The estimates at the two sites were averaged to obtain the best estimate of saltcedar ET, and then the days during each run were averaged to reduce the day to day variation associated with variable climatic conditions. The values are tabulated in table 1 and plotted in figure 1 as a basis for evaluating seasonal saltcedar ET.

The spring greenup and fall dormancy dates were set at March 23 and November 11 after inspection of the sites and trends in table 1. The growing season length was thus 233 days.

A simple trapezoid integration of the curve in figure 1 yields a total ET for the 233 day growing season of 1637 mm (1548 mm day, and 89 mm night). This total should be increased to account for precipitation, under the reasonable assumption that all of the precipitation evaporates. The BRET totals are thus increased by 42 mm during the growing season and 90 mm for the entire year, based upon mean rainfall records at Ehrenberg, 50 km to the north. The best estimate of saltcedar ET at this site in the lower Colorado River valley thus becomes 1677 mm for the growing season, and 1727 mm for the year.

Other estimates of ET for this region are quite generalized. For example, the U. S. Bureau of Reclamation<sup>4</sup> estimated that there were

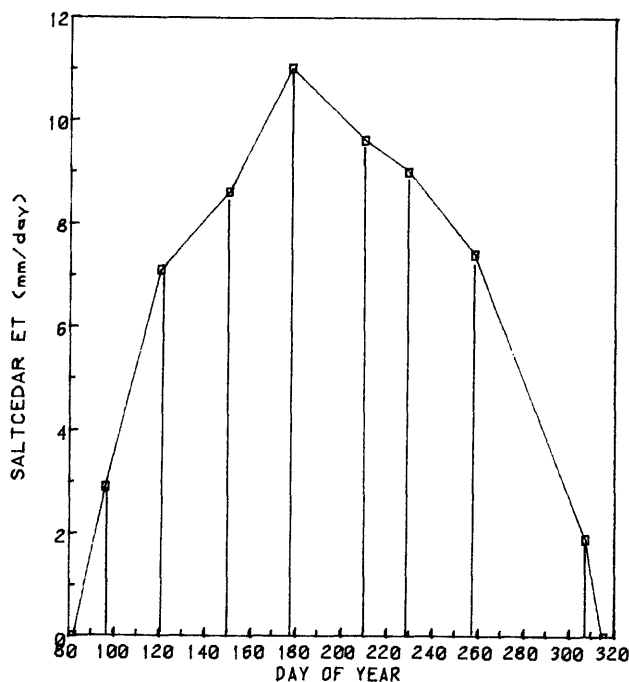

Figure 1. Mean ET rates at the saltcedar site. Seasonal totals obtained by trapezoid rule.

<sup>4</sup> U. S. Bureau of Reclamation. 1964. Pacific Southwest Water Plan. Supplemental Information Report on Water Salvage Projects - Lower Colorado River. USBR, Boulder City, NV.

Table 1. Mean daily ET totals (in mm). Means are for two masts and dates shown (Gay and Hartman, 1982).

	day	night <sup>1</sup>	24-hour
Apr 6, 7	- 2.8	-0.1	- 2.9
Apr 28, 29	- 6.8	-0.3	- 7.1
May 28, 29, 30	- 8.2	-0.4	- 8.6
Jun 26, 27, 28	-10.5	-0.5	-11.0
Jul 28, 29	- 9.0	-0.6	- 9.6
Aug 15, 16, 17	- 8.4	-0.6	- 9.0
Sep 12, 13	- 6.9	-0.5	- 7.4
Oct 30-Nov 2	- 1.8	-0.1	- 1.9

<sup>1</sup> night column contains interpolated data.

4,593 ha of saltcedar on reach number 4, which extends from Blythe-Ehrenberg south to a point just downstream from the BREB measurement site. The Bureau estimated the annual water use to be 1359 mm, excluding precipitation, using the Blaney-Criddle formula adjusted for the density of vegetation throughout the reach. The agreement with the BREB estimate is rather good, considering that the saltcedar at the BREB site was quite dense, and the water use there should be at a near maximum rate.

More speculative estimates from other regions range up to 2100 mm for the Gila River near Phoenix (Horton and Campbell, 1974). The climatic conditions on the lower Colorado are warmer and drier than on the Gila, and it seems unlikely that vegetation density and water availability there could be favorable enough to generate water use as high as the estimates of Horton and Campbell.

## CONCLUSIONS

The energy budget technique is a well known, physically based method for evaluating energy used to vaporize water at an evaporating surface. The method gave consistent, reproducible results at the saltcedar site. The method has become even more attractive with the recent development of portable, battery powered, energy budget systems that will facilitate sampling a variety of vegetative and environmental conditions (Gay and Greenberg, 1985).

The BRET measurements reported here form a unique data set for dense riparian vegetation, with water freely available in a hot, arid climate. The growing season and yearly ET totals estimated from these measurements, 1677 and 1727 mm respectively, including 90 mm of mean annual precipitation, were considerably less than the 2100 mm projected for saltcedar on the Gila River near Phoenix by Horton and Campbell (1974). The Colorado River saltcedar water use was in general agreement with water use by irrigated alfalfa. The saltcedar BRET measurements were quite consistent, and it is felt that an estimate of 1700 to 1750 mm yearly ET is reasonable for dense saltcedar along the lower Colorado River.

#### LITERATURE CITED

- Bowen, I. S. 1926. The ratio of heat losses by conduction and evaporation from any water surfaces. *Phys. Rev.* 27:779-787.
- Fritschen, L. J., and L. W. Gay. 1979. *Environmental Instrumentation*. Springer Verlag, New York. 216 pp.
- Gay, L. W. 1979. A simple system for real-time processing of energy budget data. *Proceedings, WMO Symposium on Forest Meteorology, Ottawa*. Pp. 81-83. WMO No. 527, Geneva.
- Gay, L. W., and L. J. Fritschen. 1979. An energy budget analysis of water use by saltcedar. *Water Resources Res.* 15:1589-1592.
- Gay, L. W., and R. J. Greenberg. 1985. The AZET battery powered Bowen ratio system. *Proc. 17th Conf. Agric., Forest Meteor.*, pp. 181-182. Amer. Meteor. Soc., Boston.
- Gay, L. W., and R. K. Hartman. 1981. Evapotranspiration from irrigated alfalfa and riparian saltcedar. *Proc. 15th Conf. Agric., Forest Meteor.*, pp. 94-97. Amer. Meteor. Soc., Boston.
- Gay, L. W., and R. K. Hartman. 1982. ET measurements over riparian saltcedar on the Colorado River. *Hydro., Water Resources Ariz. and Southwest*. 12:9-15. Ariz. WRRRC, Univ. Arizona, Tucson.
- Hartman, R. K., and L. W. Gay. 1981. Improvements in the design and calibration of temperature measurement systems. *Proc., 15th Conf. Agric., Forest Meteor.*, pp. 150-151. Amer. Meteor. Soc., Boston.
- Horton, J. S., and C. J. Campbell. 1974. Management of phreatophyte and riparian vegetation for maximum multiple use values. Res. Paper RM-117. USDA Forest Service, Rocky Mtn. Forest and Range Expt. Station, Fort Collins.
- Osmolski, Z., and L. W. Gay. 1983. Comparison of Bowen ratio estimates from two sets of sensors. *Proc., 16th Conf. Agric., Forest Meteor.*, pp. 77-78. Amer. Meteor. Soc., Boston.
- Sellers, W. D., and R. H. Hill. 1974. *Arizona Climate 1931-1972*. Univ. Arizona Press, Tucson. 616 pp.
- Spittlehouse, D. L., and T. A. Black. 1980. Evaluation of the Bowen ratio/energy balance method for determining forest evapotranspiration. *Atmos.-Ocean* 18:98-116.
- Tanner, C. B. 1960. Energy balance approach to evapotranspiration from crops. *Soil Sci. Soc. Amer. Proc.* 24:1-9.
- Verma, S. B., N. J. Rosenberg and B. L. Slad. 1978. Turbulent exchange coefficients for sensible heat and water vapor under advective conditions. *J. Appl. Meteor.* 17:330-338.

**Acknowledgements:** The work reported here was supported in part by the Arizona Agricultural Experiment Station, and in part by federal funds provided by the U. S. Department of the Interior, as authorized under the Water Research and Development Act of 1978 (P. L. 95-467). Approved for publication as Paper No. 540, Arizona Agricultural Experiment Station.

# Quantification of Nitrate Uptake by Riparian Forests and Wetlands in an Undisturbed Headwaters Watershed<sup>1</sup>

Jonathan Rhodes<sup>2</sup>, C.M. Skau<sup>3</sup>, Daniel Greenlee<sup>4</sup>, David L. Brown<sup>5</sup>

---

Three years of research on a headwaters watershed has shown this area to be capable of removing over 99% of the incoming nitrate nitrogen. Riparian vegetation nitrate uptake and output, and microbial denitrification will be incorporated into hydrologically-based nutrient transport models.

---

## INTRODUCTION

Lake Tahoe in the northern Sierra Nevada has been a focus of national attention due to its steadily declining water quality. This oligotrophic lake is nitrogen deficient with respect to plant growth; however, its famed clarity is disappearing at a rate of 0.6 m/year in response to algal growth fueled by accelerated nitrate inputs from man-disturbed watersheds. Research was initiated by the University of Nevada, Reno in the late 1960's to determine the nutrient sources and delivery mechanisms which are impacting Lake Tahoe.

Of the forest nutrients, nitrate and phosphate are of greatest concern since they are the eutrophication rate-limiting compounds (Kramer, 1972). In the Tahoe region, these two nutrients are found in approximately equal amounts in undisturbed watersheds (Brown, et al., 1973). Since the required nitrate to phosphate ratio for organisms is about 16:1, nitrate is the limiting nutrient, and is hence the major focus of Tahoe pollution research. It is important to differentiate between the nitrate concentration (mass per volume), and the load (the total mass) delivered by the watershed, since the latter is what will actually impact Lake Tahoe for example.

Currently, investigations are attempting to describe nitrate delivery mechanisms at the individual watershed level. Working at an experimental watershed immediately adjacent to the Lake Tahoe basin, the goal is to develop a hydrologically-based nutrient transport model which can be used to predict the extent to which watersheds will release nutrients. Riparian wetland areas are emerging as one of the most important parameters in controlling nutrient transport.

Nitrate can enter an undisturbed watershed from two major sources: precipitation and nitrogen-fixation by alder and other plants (Swank, 1984). Upon entering the soil, nitrate can undergo a variety of transformations which result in assimilation into tissues in microbes and plants (uptake), microbial reduction into nitrous oxide and nitrogen gas (denitrification), and adsorption onto soil particles (mineralization). With the exception of sediment-adsorbed nitrates, these transformations remove dissolved nitrate from soil and groundwater before they enter the stream, thereby minimizing the watersheds impact on Lake Tahoe.

These processes are all closely linked with the hydrologic system operating on local hill-slope watersheds. Major hydrologic variables include: inputs from rain and snowmelt, changes in soil water storage, losses and gains from fracture flow in the granite bedrock, and output in the creek. Riparian and wetland areas are key components of the watershed, contributing to streamflow generation and response to rain/snowmelt events (Hewlett and Hibbert, 1967).

## DESCRIPTION OF STUDY SITE

The study site is a 79.6 hectares (200 acre) headwaters watershed located on the east slope of the Sierra Nevada near Spooner Summit (above Carson City, Nevada). The watershed has a base elevation of 2012 m (6800 ft) rising to slightly over 2500 m (8200 ft). Northern

---

<sup>1</sup>Paper presented at the North American Riparian Conference. [University of Arizona, Tucson, April 16-18, 1985]

<sup>2</sup>Jonathan Rhodes is Graduate Research Assistant in Forest Hydrology, University of Washington, Seattle, WA.

<sup>3</sup>C.M. Skau is Professor of Forestry and Watershed Management, University of Nevada, Reno, NV.

<sup>4</sup>Daniel Greenlee is Graduate Research Assistant in Hydrology/Hydrogeology, University of Nevada, Reno, NV.

<sup>5</sup>David L. Brown is Graduate Research Fellow in Hydrology/Hydrogeology, University of Nevada, Reno, NV.

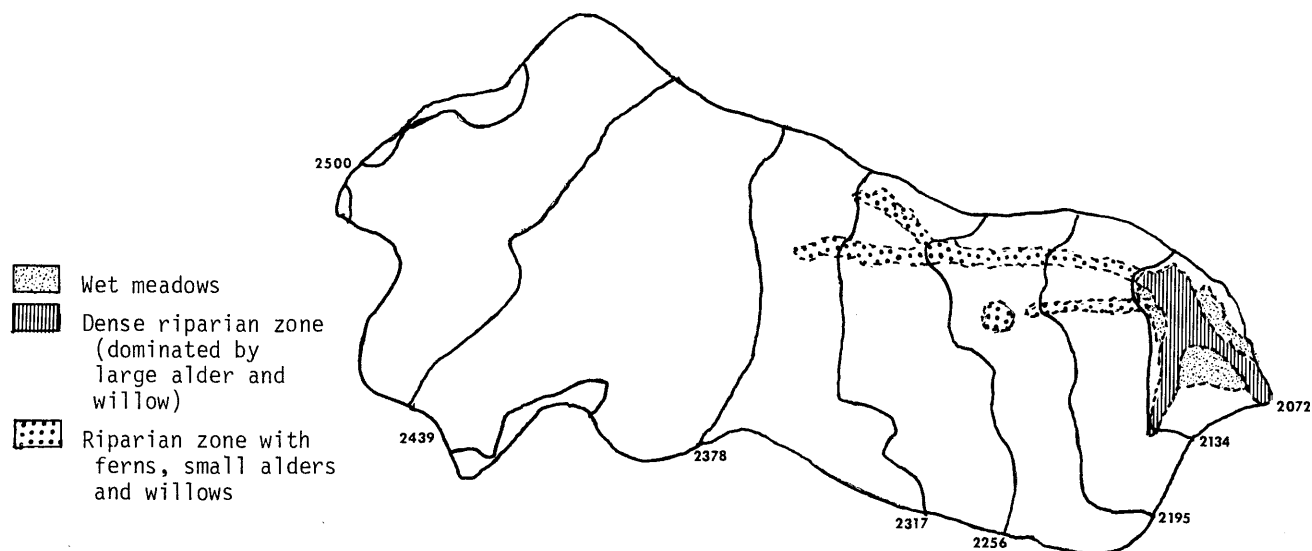

Figure 1. Clear Creek study watershed riparian and wetland areas.

aspects predominate along this east-west trending watershed with the majority of slopes ranging from 20 to 50 percent.

The watershed receives approximately 76 centimeters (30 inches) of precipitation annually. Over 80 percent of this amount occurs as snow, with the remainder usually in the form of summer and autumn rain events. The precipitation input of nitrates averages a fairly constant concentration of 34 mcg/l in fresh snow (Rhodes, 1985). This value showed little variance, ranging between 15-50 mcg/l for both record and below normal yearly precipitation totals. For 1982/83, a record high snow year, the total incoming load from rain and snow was 449 g/ha (Rhodes, 1985).

The study area is drained by a perennial first order tributary of Clear Creek. Also present are several ephemeral and intermittent channels and springs. Flows in the creek range from 0.2 cfs in the late Summer and early Fall to a maximum of 1.0 cfs during snowmelt. Sampling the creek (1982/83) at the outlet flume showed an average nitrate concentration of 1 mcg/l (detection limits) which produces an outlet load of 2.5 g/ha.

The granodioritic soils support a mixed pine-fir forest. Soils in the riparian and spring zones are gleyed and mottled with fractions of organic matter and clay larger than the majority of the watershed. This is indicative of periodic, transient saturation.

The lower watershed is dominated by a 0.5 ha wet meadow on the north side of the creek and a 1 ha wet meadow/seep zone on the south side (fig. 1). Riparian species are predominately willow (*Salix spp.*), red alder (*Alnus tenuifolia*), horsetail (*Equisetum arvense*), ferns (*Athyrium felix-femina*), sedges, and grasses.

These species are found along the perennial and ephemeral channels, surrounding seep zones and springs, and in the wet and dry meadows.

#### INSTRUMENTATION

The Clear Creek watershed was instrumented beginning in 1982 to monitor the saturated subsurface system (46 piezometers), precipitation (a recording precipitation gage and accessory snowboards), streamflow (a recording gage on a 1.5 foot H-flume), and soil water content (36 neutron probe access tubes). The presence and levels of nitrate in the saturated/unsaturated zone were monitored using 40 pressure-vacuum soil water lysimeters. Water analysis was performed on a Dionex ion chromatograph in an EPA certified laboratory at the University of Nevada Desert Research Institute.

Riparian and wetland areas are the most intensively instrumented and monitored sites in the entire watershed. Since they respond to hydrologic inputs in a very rapid manner, it was deemed necessary to develop a monitoring system which could measure small changes in groundwater and soil moisture levels on a continuous basis.

A telemetered, remote data collection and transmission system was developed with a local firm, Scientific Engineering Instruments, Inc. (SEI). The telemetry portion of the system has been incorporated into the Soil Conservation Service's SNOTEL network, and has been very reliable under the demanding winter conditions encountered at high altitudes. This system delivers data directly to the University Watershed Lab, and thus allows real-time monitoring of changes in the watershed.

In November, 1984, a transect in the lower, northside meadow was instrumented to monitor

groundwater levels and soil moisture content (fig. 1). SEI adapted an acoustical sensing device to measure the depth to groundwater inside the standard piezometers deployed at the study site. Readings with 3 cm resolution are taken at 10 minute intervals.

Three sites comprise the transect and follow the gradient of the hill roughly parallel to the creek. The middle site has sensors on a nested pair of piezometers in order to measure the hydraulic head gradient. The upper and lower sites both contain one sensor each. Sub-surface flow pulses moving into and through the meadow and riparian zones can thus be tracked as the watershed response to snowmelt or rain.

Changes in soil moisture, particularly the downward advance of wetting fronts due to rain infiltration, can be measured using a stack of Coleman moisture/temperature probes with an SEI interface module. The probes are emplaced at 25 cm, 40 cm, and 60 cm depths. Another anticipated use of these probes and the entire system is to refine soil water sampling efforts by more accurately detecting the presence of hydrologic processes targeted for study, especially rain events.

#### NITRATE REMOVAL MECHANISMS

The difference between the precipitation input and the stream's output represents a 99 percent removal of nitrate by an undisturbed watershed. The magnitude of this removal is even greater since the contribution of nitrogen-fixation has yet to be fully quantified. This situation suggests a system which is either biologically nutrient-starved or which has an extremely high nitrate storage capacity. Even though the nitrate concentrations within the watershed and delivered in the stream are low, it is the overall efficiency of removal that is locally significant. The average nitrate concentration in the clearest center of Lake Tahoe is correspondingly low, at about 14.6 mcg/l (Goldman, 1982).

This preliminary nutrient budget suggests that outputs other than streamflow must be investigated. Riparian and wetland nitrate removal appear to be the most important means of nitrate depletion.

#### Biological Nitrate Removal

##### Microbial Denitrification

Of all the myriad biochemical transformations involving nitrogen in the nitrate ( $\text{NO}_3^-$ ) form, denitrification - the reduction of nitrate to nitrous oxide ( $\text{N}_2\text{O}$ ) and  $\text{N}_2$  gas - has been demonstrated as a highly significant removal mechanism (Greenlee, 1985), accounting for a nitrogen loss an order of magnitude higher than the inputs from precipitation. Denitrifying bacteria are active in the anaerobic saturated zone or in saturated microsites in the unsaturated soil zone.

Direct measurements of denitrification were carried out in the north-side wet meadow at the bottom of the watershed using the acetylene blockage technique (Ryden, et al., 1979a; 1979b). For the 111 samples taken thus far, denitrification rates ranged between 0.138-2.41 grams nitrogen lost per hour per hectare (0.341-7.265 g N/hr/acre).

Assuming the most conservative denitrifying conditions (8 hours per day, June through November), the 1984 total denitrification rate would have been 1770 g N/ha. While an order of magnitude less than for low elevation agricultural fields (Ryden et al., 1979a), these values are significant given the comparably low concentration and load of nitrate contained in the precipitation.

Another important finding of this study concerns the conditions under which denitrification can occur in high elevation watersheds. While soil water contents decrease during the Summer and into the Fall, sufficient amounts of saturated microsites remain so as to allow continuous denitrification in the meadows.

Microbial populations encountered in this study also appear to have adapted to lower soil temperatures than are reported for agricultural fields. Low but significant (approximately 0.484 g N/hr/ha) rates of denitrification were measured in November under a 15 cm snowpack at soil temperatures of 1.6 (10cm), 2.9 (25cm), and 4.7 (50cm) degrees Centigrade.

Apparent adaptations to high altitude conditions indicate that denitrification could be occurring year-round. Low level winter denitrification rates might even increase during mid-winter melts which periodically occur around the meadow edges. The riparian meadows and other wetlands which support populations of denitrifying bacteria thus seem to be critical natural controls in the transport of nitrate. They also offset the nitrogen-fixation inputs of nitrate from riparian and other species which can amount to several kilograms of nitrogen per hectare per year (Swank, 1984). An estimation of this input will be made for Clear Creek.

#### Coniferous Forest Nitrate Uptake

Nitrate assimilation during the addition of new forest growth may also be a significant removal process. Using forest mensuration techniques to measure annual biomass production, a conservative estimation of the conifer nitrate uptake for the Clear Creek watershed will be attempted (Budy, 1985).

#### Nitrate Storage in Soils

Working with the US Agricultural Research Service in Reno, Nevada, efforts are under way to measure the watershed's potential for nitrate mineralization. Sediment nutrient adsorption is also being studied in determining if nitrate is being transported in the stream without showing up in water quality analysis. This process is

especially relevant to the role of riparian saturated zones since they are the major source of sediment in local watersheds.

## HYDROLOGIC ROLE OF RIPARIAN AND WETLAND AREAS IN NUTRIENT TRANSPORT

### Variable Source Areas

In addition to serving as nitrate removal mechanisms, riparian and wetland areas may also actually act as conduits which rapidly transmit nitrates to the stream in response to rain events, to rain-accelerated snowmelt, or to subsurface flow inputs from the upper watershed. Described by Hewlett and Hibbert (1967), riparian areas are usually at or near saturated and thus respond hydraulically much more rapidly than other parts of the watershed. Also, since these saturated areas expand and contract in response to the influx of water, they are both temporally and spatially variable in their influence on the stream.

Coats, et al. (1976) and Melgin (1985) concluded that nitrate removal mechanisms were "short-circuited" when saturated areas prevented water from coming into contact with the soil-biological complex. In effect, these variable source areas severely reduce water's residence time in the soil, and thereby limit or eliminate the possibility of biological nitrate uptake and removal. Paradoxically, it seems that both extensive riparian/wetland areas and extended water residence times are important parameters in watershed nutrient transport.

### Water Delivery Mechanisms

Overland flow is generally absent in the Sierra Nevada since infiltration capacities usually exceed rainfall and snowmelt rates. Riparian and wetland soils show the most rapid saturation in response to rain given their higher antecedent moisture contents and shallow water tables. These soils also show a fairly high percentage of saturation (50 to 80 percent has been measured) during winter months due to groundmelt of the snowpack. This relatively low level, slow melt occurs as a result of the earth's heat loss, and causes wetlands to saturate rapidly in response to the Spring snowmelt.

### Snow Processes

Snowpacks can exhibit many properties similar to soil profiles. In some ways, snow is much more dynamic than soil since snow morphology can alter drastically or even disappear completely in a very short time. One particular snow property which may affect nutrient transport is the fractionation process.

Studies have shown that this process can concentrate nitrates at the bottom of the pack over the Winter (Johannessen and Henriksen 1978). Spring melt and subsequent runoff causes a "pulse" of nitrates to be sent through and out

of the watershed. This effectively prevents any significant nitrate removal, and increases the pollution impacts downstream. Ongoing studies with the US Geological Survey and the US Forest Service Central Sierra Snow Lab are trying to determine the extent of fractionation in Sierra snowpacks. Results to date have been inconclusive.

### CONCLUSION

The importance of riparian and wetland areas in a watershed's nutrient transport system is that of a net process, balancing vegetative inputs, potential sediment outputs, microbial and plant removal mechanisms, and hydrologic transmissive properties. These areas appear to be able to "clean up" nitrate-containing waters with a very high degree of efficiency, and are thus of major value in providing natural pollution controls for sensitive waters such as Lake Tahoe. The major challenge is to further quantify parameters such as denitrification rates, snow fractionation, plant nitrate assimilation, and sediment adsorption potentials.

Additional hillslope hydrologic research is needed regarding the watershed flow characteristics - especially in the unsaturated zones. Snow-related mechanisms such as melt, water movement through snow, and the development of macropores will be the focus of continuing research to refine their role in nutrient transport. Despite their complexity, the hydrologic, biologic, chemical, geologic, and atmospheric processes which interact in a watershed must be integrated in order to discern those key parameters which yield the greatest control over nutrient transport. Once identified, these controls can be developed into a predictive tool which can identify those watersheds with the greatest potential for the delivery of pollutants into oligotrophic waters such as Lake Tahoe.

### LITERATURE CITED

- Brown, J.C., C.M. Skau, and W. Howe. 1973. Nutrient and sediment production from forested watersheds. Proceedings: ASAE Annual Meeting. [University of Kentucky, Lexington, KY, June 17-20, 1973]
- Budy, J. 1985. Personal conversation. Range, Wildlife and Forestry Department, University of Nevada, Reno, NV.
- Coats, R.N., R.L. Leonard, and C.R. Goldman. 1976. Nitrogen uptake and release in a forested watershed, Lake Tahoe Basin, California. Ecology 51:995-1004.
- Goldman, C.R., R.P. Axler, and F.E. Reuter. 1982. Interagency Tahoe Monitoring Program, water year 1981 preliminary report. Prepared for Brown and Caldwell Consulting Engineers. Sacramento, CA.
- Greenlee, Daniel. 1985. Denitrification rates of a mountain meadow near Lake Tahoe. M.S. thesis (in progress), University of Nevada, Reno, NV.

- Hewlett, J.D., and A.R. Hibbert. 1967. Factors affecting the response of small watersheds to precipitation in humid areas. In International Symposium on Forest Hydrology. 813 p. Pergammon Press, Oxford.
- Johannessen, J., and A. Henriksen. 1978. Chemistry of snow meltwater: Changes in concentration during melting. Water Resources Research 14:614-619.
- Kramer, James R. 1972. Phosphorus: analysis of water, biomass and sediment. p. 51-100. In Nutrients in natural waters. 457 p. John Wiley and Sons, Inc., New York, NY.
- Melgin, Wendy. 1985. The influence of hill-slope hydrology on nitrate transport in a forested watershed, near Lake Tahoe. M.S. Thesis (in progress), University of Nevada, Reno, NV.
- Rhodes, Jonathan J. 1985. A reconnaissance of hydrologic nitrate transport in an undisturbed watershed near Lake Tahoe. M.S. Thesis, University of Nevada, Reno, NV.
- Ryden, J.C., L.J. Lund, and D.D. Focht. 1979a. Direct measurement of denitrification loss from soils: I. Laboratory evaluation of acetylene inhibition of nitrous oxide reduction. Soil Science American Journal 43:104-110.
- Ryden, J.C., L.J. Lund, J. Letey, and D.D. Focht. 1979b. Direct measurement of denitrification loss from soils: II. Development and application of field methods. Soil Science American Journal 43:110-118.
- Swank, Wayne T. 1984. Atmospheric contributions to forest nutrient cycling. Water Resources Bulletin 20(3):313-321.

# Aquatic Organic Carbon and Nutrient Fluxes, Water Quality, and Aquatic Productivity in the Atchafalaya Basin, Louisiana<sup>1</sup>

Victor W. Lambou<sup>2</sup>

---

Abstract.--Aquatic carbon and nutrient fluxes, water quality, and productivity in the Atchafalaya Basin, Louisiana are reviewed. Overflow areas had large areal net exports of nitrogen and dissolved organic carbon but acted as a sink for phosphorus. Ammonia levels increased dramatically during the summer. Primary production in the overflow areas was primarily above the water surface and energy chains within the water are basically dependent upon heterotrophic production.

---

## INTRODUCTION

The Atchafalaya Basin contains one of the largest remaining floodplain bottomland hardwood forests in the United States and supports major sport and commercial fisheries and outdoor recreational uses dependent upon the annual flooding of the forest (Lambou 1985). This paper reviews aquatic carbon and nutrient fluxes, water quality, and productivity in the Basin.

## DESCRIPTION OF AREA

The Atchafalaya Basin (fig. 1) comprises an 8,345 km<sup>2</sup> lowland floodplain area confined between natural levee ridges that delineate the present and former courses of the Mississippi River. Its overall dimensions are approximately 72 by 193 km with elevations ranging from 15 m to sea level.

There are six segments in the Atchafalaya Basin which have integrity due to manmade levee systems. These are: (1) the 287 km<sup>2</sup> Morganza Floodway, (2) the 611 km<sup>2</sup> West Atchafalaya Floodway, (3) the 340 km<sup>2</sup> Pointe Coupee Sump Area, (4) the 2,129 km<sup>2</sup> Atchafalaya Basin Floodway--historically subject to frequent and prolonged natural flooding, (5) the 259 km<sup>2</sup> leveed Atchafalaya River and other segments located mainly between the upper Atchafalaya River and levees and Old River, and (6) the 4,719 km<sup>2</sup> East and West Basin areas

isolated by levees. Of most value from a fisheries and recreational standpoint is the Atchafalaya Basin Floodway, which during normal years has in excess of 1,619 km<sup>2</sup> flooded by overflow from the Atchafalaya River.

Water normally enters the Basin from two major sources. A portion of the Mississippi River's flow enters through the Old River Control structures and eventually joins with the Red River to form the main stem of the Atchafalaya River. The main stem flows are then confined by levees until the river enters the Atchafalaya Basin Floodway. There the water spreads out through distributaries and during high water by overbank flows over almost the entire Atchafalaya Basin Floodway. The water exits through the Wax Lake and Lower Atchafalaya River outlets.

The Atchafalaya River receives approximately 30% of the combined flows of the Mississippi and Red Rivers at the latitude of the Old River Control structures. Atchafalaya River discharges show both seasonal and annual variation. The "average shifted hydrograph" for the Atchafalaya River at Simmesport indicates the seasonality of flows (fig. 2). The hydrograph was computed from daily discharges at the latitude of Old River and adjusted to 30 percent of the total flow to account for the presence of the Old River structures. Each year's hydrograph was shifted to peak on April 15 (the day the unshifted average hydrograph peaked) before averaging, since daily averages of unshifted hydrographs result in considerably lower peak stages than is representative of actual conditions.

The cyclic nature of the flows shown in figure 2 also describes the typical annual regime of overflow for the Atchafalaya Basin Floodway. The other segments of the Basin are not subjected to the same type of prolonged overbank flooding.

---

<sup>1</sup>Presented at The First North American Riparian Conference, Riparian Ecosystems and their Management: Reconciling Conflicting Uses, Tucson, Arizona, April 16-18, 1985.

<sup>2</sup>Victor W. Lambou is with the Environmental Monitoring Systems Laboratory, United States Environmental Protection Agency, Las Vegas, Nevada.



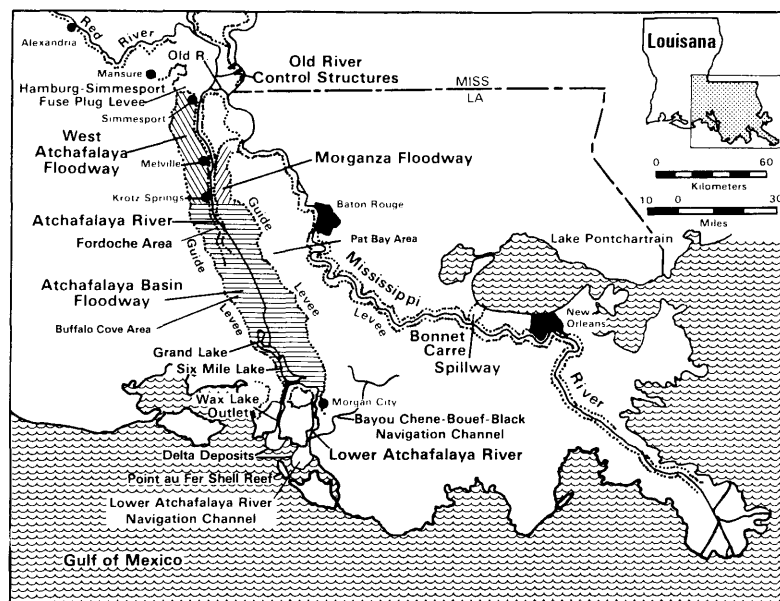

Figure 1.--The Atchafalaya Basin, Louisiana.

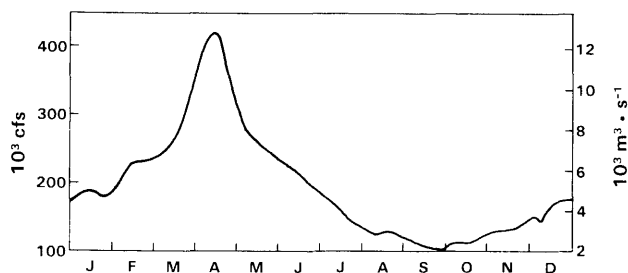

Figure 2.--Average daily shifted hydrograph for the Atchafalaya River at Simmesport, Louisiana, for the period 1947-48, adopted from U.S. Army Corps of Engineers (1982).

Detailed comparisons are made in this report for three distinct hydrological subunits within the Basin. Two of these, Fordoche and Buffalo Cove, are part of the Atchafalaya Basin Floodway and show seasonal water-level patterns that mimic those of the Atchafalaya River. The Fordoche subunit receives some local runoff from outside the leveed Atchafalaya system which is not true of other hydrological subunits within the Atchafalaya Basin Floodway. The third subunit, Pat Bay, is isolated from the historical influence of the river by manmade levees. Water-level patterns in this unit are now determined exclusively by local runoff. Hydrological patterns of the three subunits studied are compared in table 1.

#### MATERIALS AND METHODS

A total of 148 sampling stations were located throughout the Atchafalaya Basin. Locations included the major inlet and outlets to the Atchafalaya Basin Floodway and major water exchange

points within the Atchafalaya Basin Floodway. Helicopters were employed to collect water and biological samples on 14 separate occasions from 1974-77 at which time 80 to 130 stations throughout the Basin were sampled in approximately 10 days. Intensive sampling of five areas (Fordoche, Buffalo Cove, Pat Bay, inlet of the Basin proper, Atchafalaya River main stem, and the outlets of the Basin proper - Wax Lake and Morgan City) was conducted using small boat crews on approximately a monthly basis.

Integrated samples for chlorophyll *a* (CHLA) and organic carbon were collected by pumping. CHLA samples were integrated from the lower limit of the photic zone to the surface while carbon samples were integrated from top to bottom. Samples for total phosphorus (TP), dissolved orthophosphate (OP), nitrite-nitrate nitrogen (NO<sub>2</sub>NO<sub>3</sub>N), ammonia (NH<sub>3</sub>N), total kjeldahl nitrogen (KJEL), dissolved oxygen (DO), total alkalinity (TALK), and pH were collected at selected depths to represent the water column. In extremely shallow water or in fast moving main channel areas, samples were collected only from the surface. In a previous study, it was determined that in fast flowing waters in main channel areas physical and chemical constituents are uniformly mixed (U.S. DI 1969). Samples were collected on a total of 1,301 station-day combinations. The sampling methods and design are more fully described by Hern et al. (1980).

Analyses were performed in accordance with the procedures described in EPA (1971, 1974) except for chlorophyll *a* and water transparency. Chlorophyll *a* analyses were performed according to the fluorometric procedure described by Yentsch and Menzel (1963) and corrected for pheophytin while water transparency was measured in the field by Secchi disk readings. Total organic carbon (TOC)

Table 1.--Comparison of three hydrological subunits within the Atchafalaya Basin

Hydrological subunit (area)	Period flooded (months)	Area flooded (km <sup>2</sup> )	Area flooded (%)	Average maximum depth of flooding (m)	Type of flooding
Buffalo Cove	0- 1	3	3	<0.1	Overbank flooding: a) headwater to backwater; b) active exchange of water between overbank areas, permanent water bodies and major channels.
Within	1- 4	9	10	0.4	
Atchafalaya	4- 8	47	52	0.8	
Basin Floodway (91 km <sup>2</sup> )	8-11 11-12	17 15	19 16	1.1 >1.1	
Fordoche	0- 1	97	36	<0.1	Overbank flooding: a) backwater to headwater; b) active exchange of water between overbank areas, permanent water bodies and major channels.
Within	1- 4	20	7	0.4	
Atchafalaya	4- 8	56	21	0.8	
Basin Floodway (270 km <sup>2</sup> )	8-11 11-12	20 77	7 29	1.0 >1.0	
Pat Bay	0- 1	24	54	<0.1	Flooding associated with local precipitation events: a) flooding generally short-lived and involves relatively small percent of the area; b) shallow "rainwater swamps" created with flooding periods highly variable ranging from 1 to 11 months; c) minor water exchange between "rainwater swamps" and permanent water bodies; d) water loss from "rainwater swamps" largely by evapotranspiration.
Outside	1- 4	5	12	0.0	
Atchafalaya	4- 8	9	19	0.2	
Basin Floodway (45 km <sup>2</sup> )	8-11 11-12	4 3	8 7	0.4 >0.4	

was determined from unfiltered samples while dissolved organic carbon (DOC) and dissolved nutrients were determined from samples filtered through type HA 0.45-micron Millipore filters. Particulate organic carbon (POC) was determined by subtraction. Total nitrogen (TN), organic nitrogen (ON), and inorganic nitrogen (ION) were determined by addition or subtraction as follows: KJEL + NO<sub>2</sub>NO<sub>3</sub>N, KJEL - NH<sub>3</sub>N, and NH<sub>3</sub>N + NO<sub>2</sub>NO<sub>3</sub>N, respectively. See Hern et al. (1980) for more details.

In order to determine ambient parameter means, calculations were performed in such a way to give equal weight to each depth sampled at a station on a particular day, each day sampled at a station during a time interval, and each station sampled in a given geographical area during a time interval. If a parameter was not sampled on at least three different days during a time interval, the station was not used in determining the mean value for the time interval. The ratio of TP to ION (N/P) was determined only when data points for TP, NH<sub>3</sub>N, and NO<sub>2</sub>NO<sub>3</sub>N values were all available. Seasons were defined as follows: winter, December 21-March 20; spring, March 21-June 20; summer, June 21-September 20; and fall, September 21-December 20. High water was defined as any time flows in the Atchafalaya River at Simmesport were  $\geq 4,799 \text{ m}^3 \cdot \text{s}^{-1}$  (the mean discharge for a 9-year period, 1963-1971) and low water as any time flows were  $< 4,799 \text{ m}^3 \cdot \text{s}^{-1}$ .

Using topographic data from U.S. Army Corps of Engineers and U.S. Geological Survey maps, a storage curve was developed for the Fordoche, Buffalo Cove, and Pat Bay hydrological subunits. These curves relate water-level changes at key gauging stations to the net volume of water added or released from the subunit during a given time interval. Time intervals over which net storage changes were determined extended over one or more days during which water-level changes were in a single direction. Storage changes due to precipitation and evapotranspiration were determined by using daily precipitation values from the nearest U.S. weather station and average monthly evapotranspiration rates as obtained through water balance calculations from long-term records (1945-1968) at those stations. The remaining part of the storage change then represented the net change in water volume as a result of inflow,

outflow, or a combination of the two. Annual net inflow and outflow volumes determined for the period July 1, 1976 through June, 1977 are:

	inflow <u>10<sup>6</sup>m<sup>3</sup></u>	outflow <u>10<sup>6</sup>m<sup>3</sup></u>
Buffalo Cove	254	267
Fordoche	1,179	1,348
Pat Bay	57	79

These volumes were then proportioned to the various water exchange points within the Fordoche or Buffalo Cove subunit. For the Pat Bay subunit, intermittent discharge measurements over the period did not allow for apportioning of outflow or inflows and did not suggest simultaneous occurrence of inflow or outflow. This subunit was therefore treated as a single inlet-outlet system in which net storage change due to the flow was equated to actual inflow or outflow. Carbon fluxes were determined by multiplying carbon concentration times flow volumes at each major opening of the various hydrological subunits for the period July 1, 1976 through June, 1977.

Carbon and nutrient fluxes for the Atchafalaya Basin Floodway were determined by using published daily flow records for the Atchafalaya River (U.S. GS 1976, 1977). As flow data were only available for the inlet to the Floodway (115,060 10<sup>6</sup>m<sup>3</sup> for the period July 1, 1976 through June, 1977), it was assumed that all water entering the system must exit through the two outlets. This is reasonable considering the fact that changes in volume due to precipitation and evapotranspiration are negligible compared to the volume of water (fig. 2) entering and leaving the system. The inflow water was proportioned to 60 percent exiting through the Lower Atchafalaya River outlet and 40 percent through the Wax Lake outlet, based on data collected by the U.S. Corps of Engineers. Fluxes were determined by multiplying concentrations times flow volumes during the period July 1, 1976 through June, 1977. A measured concentration on a particular sampling day was assumed to be representative of the concentration in the inflow or outflow for a period of time halfway back to the previously and forward to the next measured concentration.

RESULTS AND DISCUSSION

Carbon and nutrient fluxes are presented in table 2. Even though the entire leveed Atchafalaya Basin drains directly or indirectly through the Atchafalaya Basin Floodway, I feel it is inappropriate to use the Basin's total area to calculate or determine areal net export for the Atchafalaya Basin Floodway. The processes which control internal input to the system, as well as deposition and conversion, take place mainly within the area subject to overflow, and this area is totally within the Atchafalaya Basin Floodway.

Fundamental differences exist in carbon fluxes between those areas which are subject to extensive overflow (Atchafalaya Basin Floodway, Buffalo Cove, and Fardoche) as compared to the non-overflow subunit (Pat Bay). The overflow areas had large annual areal net exports of DOC while the non-overflow subunit had a relatively low areal net export. Areal export of POC was high in the non-overflow subunit while the overflow areas acted as sinks for POC. Weighted mean DOC concentrations in the outflow of the overflow areas increased over the concentrations in their inflow. There were some differences in carbon fluxes between the Atchafalaya Basin Floodway as a whole and its two overflow subunits which were sampled. The Atchafalaya Basin Floodway acted as a sink for TOC mainly through the loss of POC.

Quantities of POC decreased by 35 percent in its outflow over that in its inflow, while quantities of POC decreased by only 17 percent and 16 percent in the outflow of its two overflow subunits. Net export of DOC was very similar for all three areas.

The greater deposition rate of POC in the Atchafalaya Basin Floodway can be explained by historical changes in sedimentation patterns and water flows. Flows from the Mississippi River began to be diverted on a regular basis to the Atchafalaya River in the mid-1900s (Fisk 1952). Diversion steadily increased until 1963 when the Old River Control structures (fig. 1) were placed into operation in order to prevent the complete capture of the Mississippi River by the Atchafalaya River. The deposition of sediments associated with the increase flows have almost eliminated Grand and Six Mile lakes which originally occupied a significant portion of what is now the Atchafalaya Basin Floodway (Fisk 1952, Roberts et al. 1980). Presently, the main area for sedimentation is rapidly changing to the Bay area below Morgan City. However, significant amounts of sediments are still being deposited in remanent lakes and backswamp areas as well as on developing natural levees in the lower portion of the Atchafalaya Basin Floodway. I believe that as part of this process, large quantities of POC are being deposited causing the Basin to act as a sink for TOC and,

Table 2.--Annual nutrient and organic carbon fluxes for the Atchafalaya Basin Floodway and organic carbon fluxes for Buffalo Cove, Fardoche, and Pat Bay

	Import		Gross Export		Net export kg·10 <sup>3</sup>	Ratio of net export to import (%)	Aeral net export (kg·km <sup>-2</sup> )
	kg·10 <sup>3</sup>	Weighted mean (mg·l <sup>-1</sup> )	kg·10 <sup>3</sup>	Weighted mean (mg·l <sup>-1</sup> )			
Atchafalaya Basin							
<sup>1</sup> Floodway (2,129 km <sup>2</sup> )							
TOC	1,119,361	9.73	899,827	7.82	-219,534	-20	-103,116
DOC	437,598	3.80	461,383	4.01	23,785	5	11,172
POC	681,762	5.93	438,443	3.81	-243,319	-36	-114,288
TP	31,746	0.28	24,427	0.21-	-7,319	-23	-3,438
OP	5,155	0.04	6,672	0.06+	1,517	29	713
TN	133,734	1.16	157,260	1.37+	23,526	18	11,050
NH3N	12,713	0.11	16,969	0.15+	4,256	33	1,999
NO2NO3N	71,792	0.62	76,914	0.67+	5,122	7	2,406
KJEL	61,942	0.54	80,346	0.70+	18,404	30	8,644
ON	49,230	0.43	63,378	0.55+	14,148	29	6,645
ION	84,504	0.73	93,882	0.82+	9,378	11	4,405
Buffalo Cove (91 km <sup>2</sup> )							
TOC	2,173	8.56	2,881	10.78	708	33	7,776
DOC	652	2.57	1,621	6.06	969	148	10,650
POC	1,522	5.99	1,260	4.71	-261	-17	-2,873
Fardoche (270 km <sup>2</sup> )							
TOC	13,513	11.46	15,738	11.67	2,225	17	8,240
DOC	7,145	6.06	10,286	7.63	3,142	44	11,636
POC	6,369	5.40	5,452	4.04	-916	-14	-3,396
Pat Bay (45 km <sup>2</sup> )							
TOC	698	12.08	1,126	14.21	427	61	9,490
DOC	439	7.58	488	6.61	50	11	1,105
POC	260	4.49	637	8.04	377	145	8,385

<sup>1</sup>If the area is considered to be the entire leveed Atchafalaya Basin (3,626 km<sup>2</sup>) the areal net export in kg·km<sup>-2</sup> for TOC, DOC, POC, TP, OP, TN, NH3N, NO2NO3N, KJEL, ON, and ION would be -60,544; 6,560; -67,104 -2,018; 418; 6,488; 1,173; 1,413; 5,076; 3,902; and 2,586, respectively.

when sediment deposition decreases sufficiently, the Atchafalaya River will become a net exporter of TOC to the estuarine area below Morgan City.

The Atchafalaya Basin Floodway had a large areal net export of TN mostly in the form of ON (table 2). Weighted mean concentrations increased in the outflow over the concentrations in the inflow for all forms of nitrogen. The Atchafalaya Basin Floodway acted as a sink for TP, mainly in the form of particulate phosphorus. The quantity of OP increased by 29 percent in the outflow over that in the inflow.

Taylor et al. (1984) has reviewed input-output nutrient studies in forested wetlands reported in the literature. They found that for all four studies reviewed, the wetlands acted as sinks for TN. However, Matraw and Elder (1984) found that the overflow floodplain of the Apalachicola River in Florida exported TN. The outflow mass was 20 percent greater than that in the inflow which is similar to the 18 percent for Atchafalaya Basin Floodway. Taylor et al. found that for eight studies, the forested wetlands served as a sink for TP which is consistent with the decrease of 23 percent found in the outflow over that in the inflow of the Atchafalaya Basin Floodway. However, Matraw and Elder found 23 percent more TP in the outflow from the Apalachicola River's floodplain. Undoubtedly the sedimentation in the lower portion of the Atchafalaya Basin Floodway discussed previously has had some effect on nutrient export from the Atchafalaya Basin Floodway.

Ambient parameter means for selected geographic areas within the Atchafalaya Basin Floodway

are given in table 3. Both TP and nitrogen levels found in the Atchafalaya Basin are high. NH<sub>3</sub>N levels dramatically increase during the summer in the Atchafalaya Basin Floodway undoubtedly due to the mineralization of ON via ammonification. N/P ratios are relatively low in the Atchafalaya Basin suggesting nitrogen limitation for autotrophic production (Lambou et al. 1976). However, both organic and inorganic forms of nitrogen and phosphorus are biologically available to bacteria. Complete metabolism (mineralization of carbon) at optimal rates by bacteria requires carbon:nitrogen:phosphorus ratios of approximately 100:10:1 to 100:5:1 dependent upon bacterial community composition and environmental conditions (Alexander 1961). In addition, many of the constituents of the total organic pool do not undergo rapid breakdown and therefore do not represent a significant drain upon the available nitrogen pool. Herbaceous material and leaf litter flooded during high water stages in the Basin contain sufficient nitrogen to support their breakdown by bacteria. Also, undoubtedly nitrogen fixation is an important source of nitrogen to the Atchafalaya Basin as evident by the relatively large areal export of TN. Significant fixation would be expected under the conditions of fairly low N/P ratios that occur in the Atchafalaya Basin. Dierberg and Brezonik (1983) found that nitrogen fixation was an important source of nitrogen in natural cypress swamp domes in Florida.

CHLA levels outside the leveed Atchafalaya Basin were much higher than those inside the leveed Atchafalaya Basin system (table 3) even though nutrient levels were high in both areas. The relatively lower SD readings within the

Table 3.--Ambient parameter means for selected geographic areas within the Atchafalaya Basin Louisiana

	TOC (mg·l <sup>-1</sup> )	DOC (mg·l <sup>-1</sup> )	POC (mg·l <sup>-1</sup> )	TP (µg·l <sup>-1</sup> )	OP (µg·l <sup>-1</sup> )	NH <sub>3</sub> N (µg·l <sup>-1</sup> )	NO <sub>2</sub> NO <sub>3</sub> N (µg·l <sup>-1</sup> )	KJEL (µg·l <sup>-1</sup> )	DO (mg·l <sup>-1</sup> )	CHLA (µg·l <sup>-1</sup> )	SD (l <sup>+</sup> )	pH	TALK (mg·l <sup>-1</sup> )	N/P
<sup>1</sup> Leveed Atchafalaya Basin System (79)	10.2	6.3	4.7	194	63	126	229	768	5.8	8.5	19	7.3	92	3.2
<sup>2</sup> Atchafalaya Basin Floodway (57)	9.1	5.5	4.3	176	53	118	349	697	6.0	8.4	20	7.3	93	3.8
Winter	10.3	7.2	3.7	178	60	90	334	594	7.2	3.5	28	7.3	77	3.6
Spring	9.0	5.9	4.0	219	71	57	403	674	4.7	5.0	19	7.2	80	3.0
Summer	9.9	4.4	5.4	170	36	309	294	941	5.6	16.4	18	7.5	104	5.6
Fall	7.3	4.0	4.0	123	31	61	309	596	7.7	9.5	18	7.4	109	3.3
High water	8.3	4.6	3.8	244	80	75	390	703	5.2	7.4	26	7.2	78	2.4
Low water	9.7	6.2	4.9	173	40	186	266	893	6.2	14.3	18	7.4	103	4.0
Fordoche (16)	12.1	8.3	4.8	219	77	140	169	934	4.9	9.2	19	7.2	83	1.8
Winter	16.2	12.0	5.7	215	89	85	93	856	5.5	2.8	18	7.0	47	0.8
Spring	12.2	10.0	4.0	251	110	112	198	850	3.6	9.3	23	7.0	71	1.9
Summer	12.7	6.4	6.7	275	56	369	190	1,351	3.6	13.9	15	7.2	109	2.5
Fall	9.7	4.6	5.1	159	44	120	156	899	6.4	13.9	16	7.5	112	1.9
High water	12.8	10.0	3.9	288	90	121	293	787	4.6	4.4	19	7.2	68	2.6
Low water	12.3	7.7	6.2	242	66	226	143	1,145	4.4	13.8	19	7.2	93	1.8
Buffalo Cove (16)	10.4	6.0	5.3	203	70	113	278	719	5.3	9.6	22	7.1	101	3.0
Winter	10.6	7.2	4.3	224	82	105	381	591	6.3	7.4	32	7.1	79	3.6
Spring	10.1	6.6	4.3	224	102	70	377	725	3.9	5.9	20	7.0	90	3.3
Summer	10.9	4.2	6.4	219	14	287	180	1,038	4.6	17.0	21	7.0	111	3.7
Fall	9.4	4.6	4.8	124	29	63	166	620	7.8	10.5	16	7.4	123	1.9
High water	9.0	5.1	4.0	304	144	116	359	764	4.4	10.5	35	7.1	87	2.5
Low water	11.4	6.7	7.0	256	45	181	92	1,071	5.8	16.3	18	7.1	111	1.8
Outside leveed Atchafalaya System (37)	11.4	6.6	5.6	207	54	155	303	1288	7.2	15.0	13	7.8	89	2.5
Pat Bay (5)	12.4	8.0	5.2	187	68	157	119	857	5.6	12.7	23	7.6	109	1.7
Winter	11.3	8.3	3.6	151	46	57	84	723	5.3	5.8	42	7.3	95	0.9
Spring	13.8	9.4	5.5	236	98	59	146	866	4.9	12.5	15	7.6	114	1.1
Summer	11.7	6.4	6.6	224	73	237	101	1098	5.6	19.8	13	7.8	118	1.7
Fall	8.2	4.1	4.2	114	35	268	130	713	7.5	18.2	12	7.7	112	2.6

<sup>1</sup>Number of stations located within a geographic area is given in parentheses.

<sup>2</sup>Atchafalaya Basin Floodway exclusive of the Fordoche area.

Atchafalaya Basin Floodway reflect higher mineral turbidity levels.

Primary production within the overflow area is primarily above the water surface and on dry land during low water periods while energy chains within the water are basically dependent upon heterotrophic production. Hern and Lambou (1977) found phytoplankton to be approximately five times as high in Pat Bay (8,000 cells·ml<sup>-1</sup>) as in Buffalo Cove (1,800 cells·ml<sup>-1</sup>) and Fordoche (1,500 cells·ml<sup>-1</sup>). Aquatic primary productivity estimates based on oxygen production and carbon dioxide uptake were found to be in the order of two to five times greater in Pat Bay (11.1 O<sub>2</sub> and 26.8 CO<sub>2</sub> mmol·m<sup>-2</sup>·h<sup>-1</sup>) as compared to Buffalo Cove (5.2 O<sub>2</sub> and 5.4 CO<sub>2</sub> mmol·m<sup>-2</sup>·h<sup>-1</sup>) and Fordoche (7.5 O<sub>2</sub> and 16.3 CO<sub>2</sub> mmol·m<sup>-2</sup>·h<sup>-1</sup>). Based on data presented by Hern and Lambou, aquatic production/respiration ratios for Buffalo Cove and Fordoche were 0.19 and 0.34, respectively, indicating an heterotrophic system.

DO levels within the Atchafalaya Basin Floodway are sometimes relatively low because of decomposition of litter in the flooded forests (table 3). The mean DO saturation was only 61 percent inside the leveed Atchafalaya Basin system while outside the leveed system it was 80 percent. Insufficient DO in the water column can cause fish kills and/or anaerobic decomposition of organic material with concomitant releases of ammonia and other noxious gases such as hydrogen sulfide. However, before the onset of anaerobic conditions DO levels became too low to provide for the maintenance and well-being of the fish population as a whole. DO levels of 2 and 4 mg·l<sup>-1</sup> were selected to compare conditions which may be detrimental to fish populations (table 4). These levels have been reported to impact growth and development of fish or to produce lethal

Table 4.--Percent of the time DO concentrations were below 2 and 4 mg·l<sup>-1</sup> by water level and selected geographic area

	Season			Water Level			Total
	Winter	Spring	Summer	Fall	High	Low	
<sup>1</sup> Atchafalaya Basin Floodway							
No. of days measured	106	194	64	117	312	164	481
Percent of time <2 mg·l <sup>-1</sup>	2	13	4	5	9	5	8
Percent of time <4 mg·l <sup>-1</sup>	11	39	29	11	26	22	25
Buffalo Cove							
No. of days measured	35	38	19	26	67	51	118
Percent of time <2 mg·l <sup>-1</sup>	8	21	5	7	13	9	11
Percent of time <4 mg·l <sup>-1</sup>	22	50	47	11	38	25	33
Fordoche							
No. of days measured	29	58	21	46	88	66	154
Percent of time <2 mg·l <sup>-1</sup>	0	22	4	6	11	10	11
Percent of time <4 mg·l <sup>-1</sup>	0	58	61	10	34	39	36

<sup>1</sup>Atchafalaya Basin Floodway exclusive of Fordoche.

conditions even though finfish and crawfish have been found in DO levels as low as 1 mg·l<sup>-1</sup> in the Fordoche area (Lambou 1985). The majority of the low DO problems occurred in the spring.

The Atchafalaya Basin Floodway is extremely productive of aquatic life, and finfish and crawfish harvest rates of 8,797 km·km<sup>-2</sup>·yr<sup>-1</sup> per maximum area flooded have been documented (Lambou 1985). The key to the high productivity of the Atchafalaya Basin Floodway is the short, efficient, bacteria-detritus food chain (Lambou 1985). Given sufficient nutrients (nitrogen and phosphorus) and adequate DO levels, carbon becomes the lifeblood of the aquatic system. Prolonged overbank flooding, with the inundation of additional land areas containing herbaceous material and forest litter renew the carbon resources needed to drive the bacteria-detritus system.

#### LITERATURE CITED

- Dierberg, F. E., and P. L. Brezonik. 1983. Nitrogen and phosphorus mass balances in natural and sewage-enriched cypress domes. *Journal of Applied Ecology* 20:323-337.
- Fisk, H. N. 1952. Geological investigations of the Atchafalaya Basin and the problem of Mississippi River diversion. U.S. Army Corps of Engineers, Waterways Experiment Station, Vicksburg, Miss. Vol. 10, 145 pp.
- Hern, S. C., and V. W. Lambou. 1979. Productivity responses to changes in hydrological regimes in the Atchafalaya Basin, Louisiana. In: *Proc. Int. Symp. on Environmental Effects of Hydraulic Engineering Works*, pp. 93-102 Tenn. Valley Authority, Knoxville, Tenn.
- Hern, S. C., V. W. Lambou, and J. R. Butch. 1980. Descriptive water quality for the Atchafalaya Basin, Louisiana. EPA-600/4-80-014, Environmental Monitoring Series. 168 pp.
- Lambou, V. W., L. R. Williams, S. C. Hern, R. W. Thomas, and J. D. Bliss. 1976. Prediction of phytoplankton in lakes. In: *Proceedings of the Conference on Environmental Modeling and Simulation*, EPA-600/9-76-016. pp. 696-700.
- Lambou, V. W. 1985. Importance of bottomland hardwood forest zones to fish and fisheries: the Atchafalaya Basin, a case history. To be published in the *Proceedings of Bottomlands. Hardwoods Workshops*, St. Francesville, La. 63 pp.
- Matraw, H. C., and J. F. Elder. 1984. Nutrient and detritus transport in the Apalachicola River, Florida. U.S. Geological Survey water - supply paper 2196-C. 62 pp.
- Roberts, H. H., R. D. Adams, and R. H. W. Cunningham. 1980. Evolution of sand-dominant subaerial phase, Atchafalaya Delta, Louisiana. *Am. Ass. Petrol. Geol. Bull.* 64:264-278.
- Taylor, J. R., M. A. Cardamone, and W. J. Mitsch. 1984. Bottomland hardwood forests, their functions and values. *Mitsch and Associates. Louisiana, Ky.* 87pp.

- U.S. Department of the Interior. 1969. Endrin pollution in the Lower Mississippi River Basin. Federal Water Pollution Control Administration, Dallas, Tex. 213 pp.
- U.S. Environmental Protection Agency. 1971. Methods for chemical analysis of water and wastes. Analytical Quality Control Laboratory, Cincinnati, Ohio. 312 pp.
- U.S. Environmental Protection Agency. 1974. Methods for chemical analysis of water and wastes. National Environmental Research Center, Cincinnati, Ohio. 298 pp.
- U.S. Geological Survey. 1976. Water resources data for Louisiana water year 1976. U.S. Geological Survey Water-Data Report LA-76-1. 463 pp.
- U.S. Geological Survey. 1977. Water resources data for Louisiana water year 1977. U.S. Geological Survey Water-Data Report LA-77-1. 405 pp.
- Yentsch, C. S., and D. W. Menzel. 1963. A method for the determination of phytoplankton chlorophyll and phaeophytin by fluorescence. Deep Sea Res. 10:221-231.

# Management of Streamside Zones on Municipal Watersheds<sup>1</sup>

Edward S. Corbett<sup>2</sup> and James A. Lynch<sup>3</sup>

---

Abstract.--Riparian zones play a major role in water quality management. Water supply considerations and maintenance of streamside zones from the municipal watershed manager's viewpoint are detailed. Management impacts affecting water quality and quantity on forested municipal watersheds are discussed in relation to the structure of the riparian zone.

---

## INTRODUCTION

The principal rivers and lakes on which many of the major cities in the United States were first settled also served as the source of water supply. As pollution became a problem or as water supply plants were damaged by floods, many of them had to be relocated to secondary streams. Many municipalities had the foresight to obtain large uninhabited areas in which to construct water supply reservoirs. These watersheds were generally protected by planted or natural forests and produced a relatively pure water supply (Ring 1977).

Today, municipal watersheds are receiving increased use because of their environmental setting and proximity to population centers. These impacts particularly concern the municipal watershed manager who must balance the supply and quality of water against the demands for products and services. Public pressure and municipal needs are producing a new, more open policy toward watershed use.

The primary function of municipal watersheds is to provide domestic water supplies (often including those for local industries). They may be privately or publicly owned. The municipal watershed includes drainage-basin lands, protection land around reservoirs, and well fields and their recharge areas. These special watersheds are valuable community assets. Municipal watersheds can provide many goods and services in addition to high-quality water. These include income from

timber harvesting, recreation and educational opportunities, increased water yields, and others as enumerated by Corbett et al. (1975).

In the Northeast, 2,000,000 acres (809,400 ha) of watershed land are owned or controlled by more than 750 municipalities, private water companies, and state and federal agencies. Forty-one percent of this acreage is municipally owned, 13 percent is owned by private water companies, and 36 and 10 percent are under state and federal control, respectively. Ownership of an entire drainage basin for water-supply purposes is uncommon (Corbett 1970). Douglass (1983) estimated that 4 to 5 percent of the land base in the Northeast and the South is in municipal watersheds.

Forest management, maintenance of buffer zones on the edges of reservoirs and streams, and control of urbanization and agricultural development are approaches used to maintain water quality in upland reservoirs. Riparian ecosystems are ecotones between aquatic and upland ecosystems. And as Odum (1979) points out, riparian zones have their greatest value as buffers and filters between man's urban and agricultural development and his most vital life-support resource, water.

## WATER-YIELD CONSIDERATIONS

Research on forested watersheds clearly demonstrates that water yield can be increased through forest harvesting practices. The greatest potential for water yield augmentation appears to be on watersheds that have the biophysical potential to produce water for high value purposes and can be managed under sound multiple use management, such as municipal watersheds (Douglass 1983, Ponce and Meiman 1983).

Water yield can be increased by periodically harvesting timber on portions of municipal water-

---

<sup>1</sup>Paper presented at the 1st North American Riparian Conference, Tucson, Arizona, April 16-18, 1985.

<sup>2</sup>Principal Hydrologist, USDA Forest Service, Northeastern Forest Experiment Station, University Park, Pa. 16802

<sup>3</sup>Associate Professor of Forest Hydrology, The Pennsylvania State University, School of Forest Resources, University Park, Pa. 16802

sheds. In the Northeast, water yield the first year after heavy cutting will increase by 4 to 12 inches (10.2 to 30.5 cm), or approximately 109,000 to 326,000 gallons (412.6 to 1233.9 m<sup>3</sup>) of water per acre cut (Lull and Reinhart, 1967). Of special value is the increase in low summer flows. Regrowth after 5 years can reduce the water-yield increase by two-thirds; partial cuttings under all-age management have a much smaller and a shorter-lived effect on water yield than do heavy cuttings. A review of methods used to predict potential water yield augmentation from various forest management practices was published in the Water Resources Bulletin (AWRA 1983).

Where municipal ownership of watershed land is substantial, vegetation management can have a significant influence on the amount of water yielded to a reservoir system, so vegetation conversions and planting programs should be carefully evaluated. On the Baltimore, Maryland, municipal watershed, research has shown that conversion of open land to eastern white and loblolly pines decreased water yield by 238,000 gallons (900.8 m<sup>3</sup>) per acre per year (Corbett and Spencer 1975). This is equivalent to a layer of water almost 9 inches (22.9 cm) deep. Establishment of a mixed hardwood forest on an open-land watershed would not reduce water yield as much as a pine forest. Swank and Douglass (1974) found that 15 years after a mature hardwood forest was converted to white pine, annual streamflow was reduced about 20 percent below that expected for the hardwood cover.

Harvesting and/or converting riparian zone vegetation has resulted in small to insignificant increases in streamflow (Hibbert 1967), but the environmental consequences may outweigh small increases in water yield. On the Newark, New Jersey, Municipal Watershed a streamside vegetation control treatment had been practiced to remove vegetation that dropped its leaves into streams, causing color and chemical build-up in the raw water, and also to prevent the accumulation of debris that might cause stream blockage. An experiment simulating this treatment, conducted on a small portion of this watershed, showed that removing the streamside vegetation was not effective in increasing water yield. There was a definite reduction in diurnal streamflow fluctuation during the growing season, indicating that transpiration losses had been reduced (Corbett and Heilman 1975).

On the Baltimore Municipal Watershed, hardwood vegetation along the main and secondary channels on a small sub-basin was cut back from the streams for 30 to 125 feet (9.1 to 38.1 m) and the area converted to grass. Although water yield increased slightly, serious erosion was caused by the mechanical methods used to control sprout regrowth and summer stream temperatures increased significantly (Corbett and Spencer 1975).

#### WATER QUALITY CONSIDERATIONS

Controlling nonpoint-source pollution during and after forest harvesting is an essential part

of any sound watershed management plan. Excessive nonpoint-source pollution may alter forest productivity, contribute to stream eutrophication, affect aquatic biota, and cause drinking water supplies to deteriorate.

Information from experimental watersheds is sufficient to determine the probable effects of timber harvesting on water quality (Aubertin and Patric 1974, Corbett et al. 1978, Lynch et al. 1985). The most significant impacts involve changes in water temperature, turbidity/sediment levels, and concentrations of dissolved nutrients.

#### Best Management Practices

Several control strategies or best management practices (BMPs) used to minimize or prevent these impacts are described in detail by Lynch et al. (1985). Water quality data collected during the first 2 years after a commercial clearcutting in central Pennsylvania show that the BMP approach was sufficient to control most nonpoint-source pollution during and following logging. Although slight increases in turbidity and sedimentation were observed, the increases could be traced to windblown trees that had been uprooted near an intermittent stream channel. A properly designed buffer zone along this intermittent stream would have reduced the erosion hazard from the windblown trees. Increases in streamwater temperature were generally slight and possibly beneficial to the aquatic ecosystem. Nutrient concentrations remained well below maxima mandated for drinking water.

#### Stream Temperature, Turbidity, and Sedimentation

Of particular importance to municipal watershed managers during and after forest management operations is the control of turbidity, sedimentation, and stream temperature. Problems associated with increased turbidity and sedimentation include reduction in reservoir storage and stream channel water-carrying capacities, water-quality impairment and public health hazards, increased cost of water treatment, reduction in aquatic habitat productivity, and a reduction in hydrologic amenities.

In 1977 the national drinking water standards for turbidity<sup>4</sup> were strengthened. The new standards placed an additional burden on watershed managers. The regulations that became effective in June 1977 changed the turbidity parameter from a secondary (esthetic) to a primary (health) standard. The reason was a concern that microorganisms might be protected from inactivation by disinfectants by their association with particulate matter. The type of turbidity can also affect disinfection efficiency.

Water temperature and changes in light intensity in the stream zone can affect the taste, odor, and color of stream water. Under some conditions,

---

<sup>4</sup>Federal Register 40 (248):59566-59588. Dec. 24, 1975.



light and temperature increases stimulate excessive production of algae degrading raw water supplies, depleting the oxygen supply for aquatic organisms, and lowering the esthetic values of streams.

#### Water Color And Disease

The importance of organic detritus in aquatic ecosystems and its relationship to the abundance and diversity of stream benthos is being increasingly recognized (Slack et al. 1982). However, natural inputs of organic matter can also impair the quality of drinking water supplies. Undesirable color, taste, and odor have been linked to leaf litter in streams and reservoirs. Taylor et al. (1983) found that significant water quality problems are likely during extended periods of low flows and maximum leaf fall. They found increased chlorine demand and rapid regrowth of coliform bacteria in alder leaf extracts, which suggest potential disinfection problems when alder leaf impacts are significant. The formation of trihalo-methanes (suspected carcinogens) in water supplies from the reaction of chlorine with naturally occurring organic materials during disinfection processes (Rook 1974), is also of concern to municipal watershed managers.

Beaver activity is a well-known cause of both true and apparent color in natural waters. Wilen (1977) reported that controlling the beaver population and increasing streamflow gradients on a forested watershed in Massachusetts were successful in reducing levels of organic color production in raw water.

Preventing leaves and other organic debris from reaching streams is not considered practical in most forested watersheds. A measure of leaf control may be exercised by converting riparian woody vegetation from deciduous to coniferous trees (Wilen 1977). However, such a conversion could result in decreased water yields (Swank and Douglass 1974).

Another potential problem with beavers on municipal watersheds is giardiasis. This disease, caused by a protozoan *Giardia lamblia*, has recently emerged as a public health problem where water supplies are unfiltered. *Giardia* outbreaks have occurred in systems that use high-quality surface water from sparsely populated watersheds. Beavers have been implicated as one of the potential intermediate hosts of the *Giardia* cyst that is transmitted to man (Lippy 1981). Systems using surface water with disinfection as the only means of treatment should consider controlling the beaver population on water source lands. Control measures could include periodic surveys, trapping programs, and forest management practices to replace food-source trees along waterways and around reservoirs with less palatable species.

#### Buffer Zones

Buffer zones can protect streams from excessive temperature increases and from accumulations of slash and debris. They moderate siltation and nutrient leaching and provide food for many

aquatic invertebrates. If streamside management zones are to remain a viable buffer for moderating nutrient leaching they will have to be managed through selective harvesting. Old overmature stands that are not increasing rapidly in vegetative mass or humus depth become less effective in utilizing available nutrients, particularly nitrogen, and nutrient discharge into the streamwater is increased (Leak and Martin 1975).

Buffer zones for stream channel and water quality protection must be capable of long-term survival if they are to function effectively. They must be properly designed and managed to prevent failure, and should be evaluated for effectiveness annually. Environmental factors that affect buffer zone stability and stream shading have been studied by Steinblums et al. (1984). They found that the timber volume susceptible to windthrow tends to be lost during the first few years of exposure and that species composition is important in determining the occurrence and amount of windthrow.

Buffer zone widths vary with conditions on different watersheds. The most common widths are from 40 to 100 feet (12.2 to 30.5 m) on each side of the stream. A 40-foot (12.2 m) buffer zone may be adequate to prevent excessive temperature increases in small streams, but a zone of 66 to 100 feet (20.1 to 30.5 m) is usually needed to protect the stream ecosystem (Corbett et al. 1978). A wider streamside management zone may be needed where slope or soil conditions dictate, or when windthrow or sunscald may be a problem. Increased stream discharge as a result of timber harvesting can cause intermittent streams to become perennial (Lynch et al. 1985). This would permit the transport of eroded material to the main stream channels and could result in stream temperature increases, so buffer zones should be maintained along intermittent streams on municipal watersheds as well as perennial ones.

#### DISCUSSION

The impact of any land management practice on water quality should be analyzed before it is used on a municipal watershed to see what safeguards will be needed. Riparian zone management, when integrated with watershed planning, can produce economic as well as environmental benefits. Reducing contamination at the source allows more economical water treatment processes to be used. For instance, direct filtration can treat low turbidity waters of moderate color as effectively as complete conventional treatment, but at considerably lower capital and operating costs (Castorina 1977). The concept that source protection is the first line of defense for a water supply is especially important in the Northeast because for many of its surface water supplies, disinfection is the sole treatment.

The riparian zone is generally the most sensitive part of the watershed. The impacts of management are often integrated in the channel area and in the quality and timing of streamflow. Learning to read early signs of stress here will aid in

evaluating how much "management" a watershed can take.

#### LITERATURE CITED

- Aubertin, G.M. and J.H. Patric. 1974. Water quality after clearcutting a small watershed in West Virginia. *J. Environ. Qual.* 3:243-249.
- AWRA. 1983. *Water Resources Bulletin.* 19:351-419.
- Castorina, A.R. 1977. Surveillance and monitoring program for Connecticut public water supply watersheds. In: *Drinking Water Quality Enhancement Through Source Protection.* R.B. Pojasek (ed.). Ann Arbor Science Pub. Inc., Ann Arbor, MI, p. 137-149.
- Corbett, E.S. 1970. The management of forested watersheds for domestic water supplies. In: *Proc. Conference on Multiple Use of Southern Forests*, Nov. 5-6, 1969, Pine Mountain, GA, Georgia Forest Research Council, p. 35-38.
- Corbett, E.S., and J.H. Heilman. 1975. Effects of management practices on water quality and quantity - Newark, New Jersey, Municipal Watersheds. In: *Municipal Watershed Management Symposium Proc.* USDA For. Serv. Gen. Tech. Rep. NE-13, p. 47-57.
- Corbett, E.S., and W. Spencer. 1975. Effects of management practices on water quality and quantity - Baltimore, Maryland, Municipal Watersheds. In: *Municipal Watershed Management Symposium Proc.* USDA For. Serv. Gen. Tech. Rep. NE-13, p. 25-31.
- Corbett, E.S., W.E. Sopper, and J.A. Lynch. 1975. Municipal watershed management: What are the opportunities? In: *Forestry Issues in Urban America.* Soc. Am. For. National Convention Proc., Sept. 22-26, 1974, New York, NY., p. 50-57.
- Corbett, E.S., J.A. Lynch, and W.E. Sopper. 1978. Timber harvesting practices and water quality in the Eastern United States. *J. For.* 76(8):484-488.
- Douglass, J.E. 1983. The potential for water augmentation from forest management in the Eastern United States. *Water Resour. Bull.* 19:351-358.
- Hibbert, A.R. 1967. Forest treatment effects on water yield. In: *Proc. International Symposium on Forest Hydrology*, W.E. Sopper and H.W. Lull (ed.) Pergamon Press, New York, p. 527-543.
- Leak, W.B., and C.W. Martin. 1975. Relationship of stand age to streamwater nitrate in New Hampshire. *USDA For. Serv. Res. Note NE-211*, 5 p.
- Lippy, E.C. 1981. Waterborne disease: Occurrence is on the upswing. *J. Am. Water Works Assoc.* 73:57-62.
- Lull, H.W. and K.G. Reinhart. 1967. Increasing water yield in the Northeast by management of forested watersheds. *USDA For. Serv. Res. Pap. NE-66*, 45 p.
- Lynch, J.A., E.S. Corbett, and K. Mussallem. 1985. Best management practices for controlling nonpoint-source pollution on forested watersheds. *J. Soil & Water Conserv.* 40:164-167.
- Odum, E.P. 1979. Ecological importance of the riparian zone. In: *Strategies for Protection and Management of Floodplain Wetlands and Other Riparian Ecosystems.* USDA For. Serv. Gen. Tech. Rep. WO-12, p. 2-4.
- Ponce, S.L., and J.R. Meiman. 1983. Water yield augmentation through forest and range management - Issues for the future. *Water Resour. Bull.* 19:415-419.
- Ring, C.A. 1977. The water supply industry and source protection. In: *Drinking Water Quality Enhancement Through Source Protection.* R.B. Pojasek (ed.). Ann Arbor Science Pub. Inc., Ann Arbor, MI, p. 63-70.
- Rook, J.J. 1974. Formation of haloforms during chlorination of natural waters. *Water Treat. and Exam.* 23:234-243.
- Slack, K.V., L.J. Tilley, and S.S. Hahn. 1982. Detritus abundance and benthic invertebrate catch in artificial substrate samples from mountain streams. *Water Resour. Bull.* 18:687-698.
- Steinblums, I.J., H.A. Froehlich, and J.K. Lyons. 1984. Designing stable buffer strips for stream protection. *J. For.* 82:49-52.
- Swank, W.T., and J.E. Douglass. 1974. Streamflow greatly reduced by converting deciduous hardwood stands to pine. *Science* 185:857-859.
- Taylor, R.L., P.W. Adams, P.O. Nelson, and R.J. Seidler. 1983. Effects of hardwood leaf litter on water quality and treatment in a Western Oregon Municipal Watershed. *Water Resour. Res. Inst. Pub. WRR1-82*, Oregon State University, Corvallis, OR, 56 p.
- Wilén, B.O. 1977. Options for controlling natural organics. In: *Drinking Water Quality Enhancement Through Source Protection.* R.B. Pojasek (ed.). Ann Arbor Science Pub. Inc., Ann Arbor, MI, p. 375-392.

# Water Resource Conservation by Reducing Phreatophyte Transpiration<sup>1</sup>

Robert W. Ritzi, Herman Bouwer, and Soroosh Sorooshian<sup>2</sup>

---

Through managing the magnitude of depth to the water table below floodplains supporting phreatophytes, water conservation may be effected due to resulting reductions in evapotranspiration, while the integrity of the riparian ecosystem is maintained. A model of the phreatophyte-floodplain system has been developed for analyzing the method's economic feasibility.

---

## INTRODUCTION AND SCOPE

In the past, water conservation by reducing phreatophyte transpiration has most often involved eradication methods, which have presented a conflict between the interest in saving the large amount of water the plants use, and the interest in the values that come with preserving a natural riparian ecosystem. An alternative conservation method to eradication is presented here, which can maintain the riparian stand and thus reconcile the conflict, if the method proves feasible.

Evidence exists to support a relationship between depth to the water table below phreatophyte-floodplain systems, and the evapotranspiration ( $E_t$ ) rate from them. By managing the position of the water table at increased depths, yet within the range of phreatophyte root extension (salt-cedar roots have been excavated to depths of 30 meters), the  $E_t$  rate can be reduced while maintaining environmental integrity. Thus, hypothetically, pumps or drains would be installed in floodplain alluvium supporting phreatophytes. The water table would be lowered to a deeper position, resulting in a reduction in  $E_t$  after the phreatophyte root termini have deepened to the new position of the capillary fringe. If the pumped water can be substituted into regional demand, then the reduction in  $E_t$  rate represents salvaged water.

The scope of the analysis of this conservation strategy here includes the magnitude of possible  $E_t$  reductions and the cost feasibility. A modeling methodology is used. Certainly, the fea-

sibility of this conservation method will also be constrained by the political and legal implications of affecting a stream-aquifer system including the possibility of prior appropriations and of instream requirements.

## A HISTORY OF WATER CONSERVATION BY REDUCING PHREATOPHYTE $E_t$

After recognizing the relation between certain species of desert plants and the water table, O. E. Meinzer (1923, 1927) introduced the term phreatophyte (the Greek roots phreatos = well, phuton = plant) which he defined as "a plant that habitually obtains its water supply from the zone of saturation, either directly or through the capillary fringe." Early studies demonstrated this relationship by locating observation wells in phreatophyte areas and observing their influence on the water table.

Later, toward the middle of this century, the study of phreatophytes in arid areas of the western United States began to proliferate, no longer because of their usefulness, but because of their water use. Robinson (1958) attributes concern over water supply problems at this time to a prolonged drought contemporaneous to a post World War II increase in water demand, and to the spread of one non-native species, Tamarix chinenses Lour., through the stream valleys of the Southwest. Also, shortly before this time Gatewood et al. (1950), in studying the Safford Valley, Arizona to determine possible water salvage for the war industry in 1943-44, used water balance methods to measure evapotranspiration. They were perhaps the first to draw attention to the potentially large amounts of water transpired by Tamarix sp.

In 1952, Robinson estimated that phreatophytes covered 16 million acres in the western states and consumed 25 million acre-feet of water per year. While noting that these numbers may be "greatly exaggerated", Van Hylckama (1982) points out:

---

<sup>1</sup> Paper presented at the First North American Riparian Conference, Riparian Ecosystems and Their Management: Reconciling Conflicting Uses, April 16-18, 1985, Tucson, Arizona.

<sup>2</sup> Ritzi is a graduate student and Sorooshian is an Associate Professor, University of Arizona, Tucson. Bouwer is with the USDA Water Conservation Laboratory, Phoenix, Arizona.

Robinson's data served to create active, even alarmist interest in the phreatophyte problem...In the literature, salt cedars have been described as "waterhogs" (Douglass, 1954), "aggressive" (Robinson, 1965), "greedy" (Douglass, 1965), "insidious" (Sebenik and Thames, 1968), "thieves" (Robinson, 1952) and "water stealing culprits" (U.S. Information Service, 1965). These expressions indicate the emotional and propagandistic attitude that is sometimes taken towards the phreatophyte problem.

In light of his estimates, Robinson proposed the study of water salvage by either 1) replacing the plants with more beneficial ones, 2) intercepting water upstream of the plants, 3) directly destroying the phreatophytes, or 4) lowering the water table out of their reach and thus killing them. Thus began the proliferation of research into water salvage and also into measuring  $E_t$  to justify water conservation projects. By 1964, Robinson had published a report of 48 projects relating to the phreatophyte problem. Bibliographies containing together over 2,000 titles related to  $E_t$  and phreatophytes have been compiled by Robinson and Johnson (1961), Humphreys (1962), and Horton (1973).

Eradication projects to destroy and replace phreatophytes include those such as Bowser (1952), Koogler (1952), and Cramer (1952). Fox (1977) points out that the Los Angeles report of the Phreatophyte Subcommittee of the Pacific Southwest Inter-Agency Committee in 1969 lists nearly two dozen major clearing projects in Arizona. The best documented and most recent of these (Culler et al., 1982) is the eradication of some 5,000 acres on the Gila River floodplain, producing a measured reduction of 480 mm in yearly  $E_t$ .

No evidence in the literature has been found of further attempts to eradicate phreatophytes for water salvage, probably due to factors including the rapid regenerative properties of *Tamarix* sp., and the objectionable environmental consequences including loss of wildlife habitat and bee pasture, the lowered aesthetic quality, and the increase caused in erosion. Out of concern for the riparian habitat, a conference was held in 1977, titled Symposium on Importance, Preservation and Management of the Riparian Habitat, dedicated to Douglas C. Harrison whose research quantified the effects of phreatophyte control on the breeding of birds in the native riparian woodland of the Verde River.

As an alternative to eradication, substances have been applied to phreatophytes to reduce transpiration, as proposed by Horton (1976), Ffolliott and Thorud (1975), and Affleck (1975). Davenport et al. (1978) measured the  $E_t$  reduction and environmental effects due to various antitranspirants (AT). They concluded that ATs safely and significantly reduce  $E_t$  but were uneconomical to apply. At their estimated application rate of \$135/acre/month to produce a 25%  $E_t$  savings (.007 ft/day) on *Tamarix* sp., the cost is about \$634/ac-ft of water saved/year.

Lowering the water table below floodplains has been previously investigated. Early analyses were done in 1956 by the Bureau of Reclamation (reported by Affleck, 1975), in which a multiple regression equation using air temperature, precipitation, and depth to ground water was used to predict that a five-foot lowering of the water table below the Gila River from Thatcher to Glenbar, Arizona, would effect water savings of about 7,000 ac-ft annually. Bouwer (1975) presented iterative and analytical procedures for computing seepage from streams which incorporated  $E_t$ /water-depth relations for application to the phreatophyte problem.

#### RELATIONSHIP BETWEEN $E_t$ AND DEPTH TO WATER

A phreatophyte-floodplain system is here defined as the relationship between an unconfined, alluvial aquifer, a perennial stream, and phreatophytes with root termini in the capillary fringe (Figure 1).  $E_t$  from this system can be thought of as a function of three interdependent influences including 1) the availability of energy at the evaporating surface to supply latent heat demand, 2) the vapour pressure gradient between the water at the evaporating surface and the bulk air, and 3) the resistances in the water flow pathways (Hillel, 1982; Slayter, 1967). Thus, in the phreatophyte-floodplain system, in addition to factors at the surface of or external to the evaporating bodies (atmospheric evaporativity),  $E_t$  will be a function of water pathway characteristics in the soil as well as resistance to water movement within the vegetation.

It is the increase in pathway resistance in relation to depth of the water table beneath the floodplain system (D) that is of interest. In studying evaporation from bare soils, Gardner

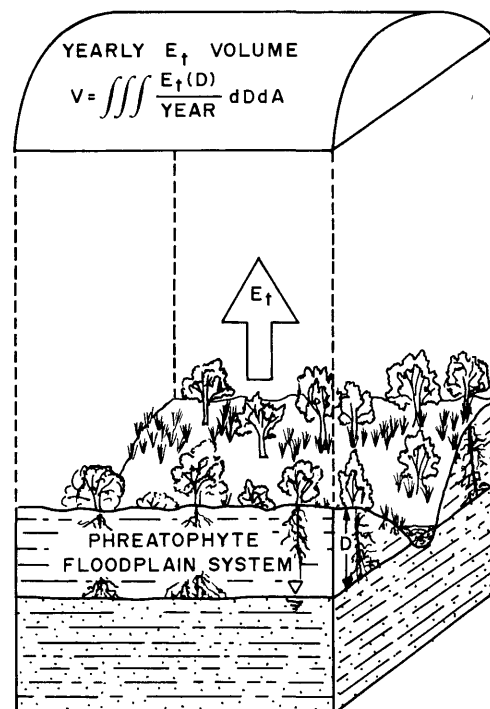

Figure 1.

(1958) has shown that in the presence of very shallow water tables, evaporativity determines the evaporation rate; however, as the depth to the water table is increased, the increase in pathway length and tortuosity became controlling factors. Under the latter conditions, at any given suction head at the surface, the evaporation rate becomes less as D increases. The relationship will vary with soil type, but generally when D exceeds 1 meter, soil evaporation becomes minor to plant transpiration.

In addition to reduced soil evaporation, the literature suggests although the data are limited, that with other factors remaining constant, phreatophytes will transpire less water with increasing D. Excavation studies have shown that phreatophytes concentrate root termini in the capillary fringe (Tomanek and Ziegler, 1963; Gary, 1965). Thus, with an unrestricted water supply, the plants can be thought of as always transpiring at the potential rate, which will lessen with increased root depth. A rigorous explanation for the relation of this phenomenon to resistances in plant pathways for water transport is not yet known. It should be noted that certain phreatophytes may exist in the absence of a water table. Turner (1974) made a distinction between facultative phreatophytes and obligate phreatophytes. The latter need uninterrupted access to the water table, while the former including *Prosopis* sp. and *Tamarix* sp., may survive indefinitely in the absence of saturated soil as zerophytes. However, this analysis will be concerned only with systems having a capillary fringe within rooting range.

In a survey of field studies measuring the water consumption of riparian vegetation, ten were found having  $E_t/D$  data. The majority involve applying water balance methods to evapotranspirometers where D is varied between 1 and 3 meters. From these, some cross sectional data are plotted in Figure 2. The data from Van Hylckama (1974) suggest a linear  $E_t/D$  relationship, having a correlation coefficient above 0.95; however, extrapolating to the abscissa gives the absurdity of zero  $E_t$  for Tamarisk with D greater than 4 meters. Thus Bouwer (1975) has suggested a sigmoidal model. Unfortunately more data outside of the D range of 1 to 3 meters such as that shown from Harr and Price

(1972) do not exist. The data from Gatewood et al (1958) show a relationship; however, their volume/density correction has been questioned (Van Hylckama, 1974).

#### METHODOLOGY

For an analysis of the system, constant evaporativity is assumed, and thus annual  $E_t$  volume for a given community is only a function of D:

$$E_t \text{ Annual Volume} = \iiint E_t(D) dD dA \quad (1)$$

where: A = surface area of the floodplain (L<sup>2</sup>)

In the absence of well defined  $E_t/D$  relationships, we can assume them and examine their sensitivity. An empirically based equation giving a sigmoidal curve is used to model the  $E_t/D$  relationship:

$$E_t = \frac{E_t \text{ MAX}}{1+(D/C)^\alpha} \quad (2)$$

where:  $E_t \text{ MAX} = E_t(0)$  (L/T)

$\alpha, C$  = empirical constants (dimensionless, L)

Curves for various  $\alpha, C$  (C in meters) are plotted in Figure 3. It is assumed that root adjustment is instantaneous with D. In addition, it is assumed that the evaporation rate from the water surface of the river occurs at rate equal to  $E_t \text{ MAX}$ . The latter assumption will tend to over-estimate  $E_t$ , because the evaporating surface of plants may greatly exceed the land area beneath their canopy, and this greater surface area more than compensates for the additional resistance in the water vapor pathway (Slayter, 1967). Examination of Figure 3 shows that because the  $E_t/D$  relationship is nonlinear, lowering the water table from 5 feet below ground surface to 6 feet below will cause greater reductions in  $E_t$  than lowering it an equal amount but from 25 feet below to 26 feet below. Thus, certain segments of the  $E_t/D$  curve can be thought of as being more effective in terms of the reduction in  $E_t$  effected by a unit change in D.

Figure 2.-- $E_t/D$  data.

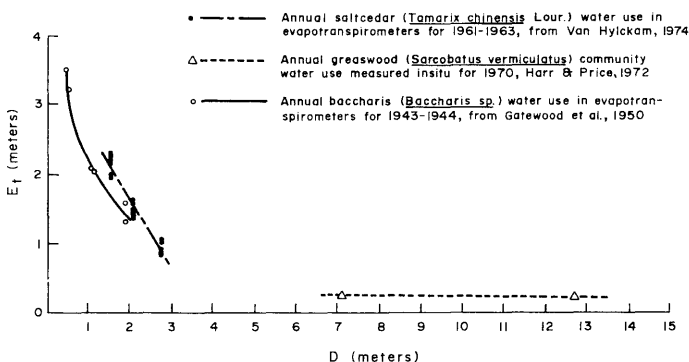
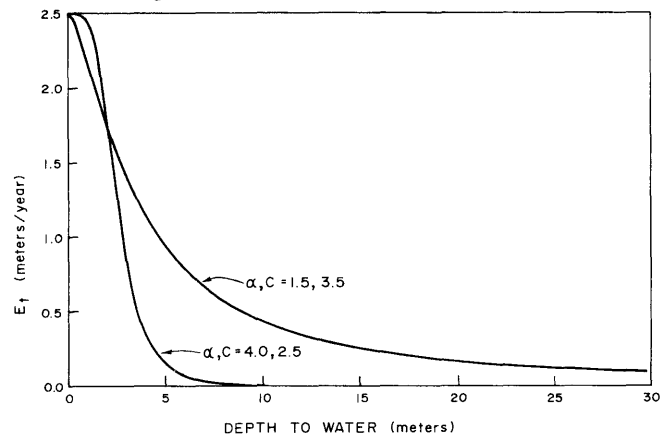

Figure 3.-- $E_t/D$  Models.



If Dupuit assumptions are made with respect to ground water flow, a two dimensional finite difference model for quifer simulation (Trescott et al, 1976) can be used, and equation 2 included as a source term to evaluate various dewatering scenarios.  $E_t$  was made a function of average D at the 2 previous iterations to assure stability of the finite difference scheme.

In defining parameters and boundary conditions for the model, it is assumed that the floodplain aquifer can be represented by a prism of homogeneous and isotropic material symmetric in shape to the river. Average dimensions are based on the Gila River, Arizona (Culler et al., 1982) including width, thickness, topography and channel dimensions. Yearly averages for streamflows, recharge and underflow are used, thus ignoring the seasonality of these components. Dirichlet boundary conditions are used at all aquifer boundaries, and a head dependent source term is used at the river. Recharge and discharge wells normal to the river at its ends, are used to simulate underflow.

### RESULTS

The prepumping, steady state water balances resulting from using  $E_t/D$  models with  $\alpha, C$  of 4, 2.5 and 1.5, 3.5 are compared to estimates for the Gila river in Table 1. Both, while representing different systems, fall within the range of estimates made for the Gila.

With pumping wells arbitrarily spaced 4,000 feet apart and 1,300 feet from the river on either side, it was possible to pump each well at a maximum of 2.2 ft<sup>3</sup>/s without the wells going dry when drawdown was calculated in a 1-foot well radius. The effects of this pumping scenario on the water table were observed after one year and again after steady-state conditions had been reached. Table 2 summarizes the computed  $E_t$  savings with the varied pumping rates, duration, and values of  $\alpha, C$ .

Costs of water saved by lowering the water table include well field installation, operation, and maintenance costs. However, when both fixed and maintenance costs are amortized over the life of the pumping system, they become negligible to energy costs. In light of this and the fact that fixed cost estimates are subject to large variation, only energy requirements will be analyzed.

Power plant and pump efficiency were assumed to be 50%. Electric pumping plants were assumed

Table 1.--Alluvium Water Balance At Steady-state Conditions. Numbers are in ft<sup>3</sup>/s

	$\alpha, c=4, 2.5$	1.5, 3.5	As calculated by Hanson & Culler
$E_t$	-10.32	-11.98	-7.28 to -12.52
Leakage	5.56	7.14	2.92 to 8.08
Recharge	4.81	4.81	3.64 to 5.22
Underflow	±1.0	±1.0	2.57

along with an energy cost of \$0.08/kw-hr. Based results by Campbell & Lehr (1973), at 50% efficiency pump power consumption is 1.5 kw/HP. Results are compared in Table 3.

### DISCUSSION

For the  $E_t/D$  models and pumping scenario used, the steady-state results of  $E_t$  reduction range from 20 to 45%. For perspective, if Robinson's 1952 estimate of 25 million ac-ft/yr for phreatophyte consumption were reduced by 20%, the resulting saving would amount to over three times the annual amount of water to be provided by the Central Arizona Project (assuming annual deliveries of 1.5 million ac-ft, Arizona Department of Water Resources, 1980).

The results show that a maximum reduction in  $E_t$  for this scenario occurs with the model having  $\alpha, C$  values of 2.5, 4 m with a pumping rate of 2.2 ft<sup>3</sup>/s. Increasing the pumping rate by 22% from 1.8 to 2.2 ft<sup>3</sup>/s causes a 4 to 7% increase in  $E_t$  savings, and yet the energy costs for any rate are under \$50/ac-ft of water saved. The volume of water produced by pumping is 4 to 6 times the volume of water saved by reducing  $E_t$ . A continual pumping rate of 2.2 ft<sup>3</sup>/s represents roughly a 3,000 ac-ft/yr per 4,000 ft of river water supply at a cost below \$10/ac-ft. Clearly these costs are low when compared to other large southwestern water projects such as the Central Arizona Project, for which estimates of actual water costs have been as high as \$300/ac-ft.

The cross sections of the floodplain in Figure 4 show that river flow is slightly maintained for  $\alpha, C$  of 2.5, 4 at maximum D, but is not for the other system. These results are important from an environmental standpoint. Clearly, the phreatophyte system is maintained in either case; however, the non-phreatophyte component of the riparian ecosystem would be altered. Thus, pumping rate must be constrained by instream water requirements to maintain environmental integrity.

It is interesting to note that the maximum reduction in the  $E_t$  rate for a given set of conditions is approached or reached by the end of the

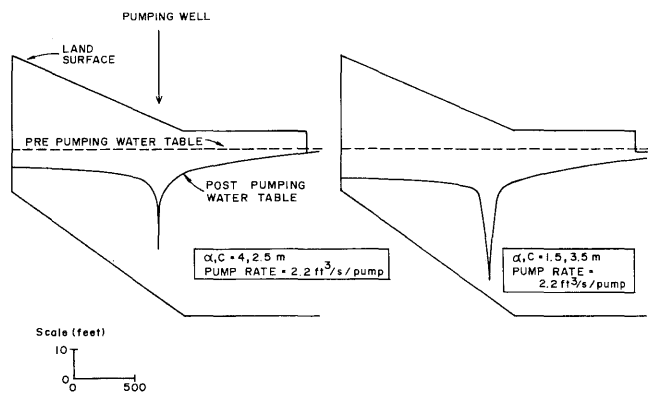

Figure 4.--Floodplain cross sections.

Table 2.--Computed  $E_t$  savings with aquifer dewatering using the eight-well scenario

$\alpha, C =$	1.5, 3.5				4, 2.5	
	1.8	1.8	2.2	2.2	1.8	2.2
Pump rate (ft <sup>3</sup> /s)						
Duration	1 yr	9.13 yrs (steady-state)	1 yr	60.9 yrs (steady-state)	1 yr (steady-state)	1 yr (steady-state)
$E_t$ rate (ft/yr):						
Pre-pumping	4.4467	4.4467	4.4467	4.4467	3.8290	3.8290
Post pumping	3.6024	3.5850	3.3936	3.3554	2.3964	2.1238
Savings	0.8443	0.8617	1.0531	1.0913	1.4326	1.7052
Reduction	18.99%	19.38%	23.68%	24.54%	37.42%	44.53%

first year. This results from the assumption of an instantaneous root adjustment by the plants. How root systems of phreatophytes will respond to dewatering is not well known. Tamarisk roots have been measured to grow 30 inches in the first year to the bottom of phytometers by Merkel and Hopkins (1957) and Tomanek and Ziegler (1963). The latter authors have suggested that maximum root depth may be determined by the position of the water table at a critical time in the life of the plant. Unfortunately, time series data for root extension do not exist. If the roots of one generation of plants are in fact not capable of recovering to a new position, it may take generations of plants with increasing root depth before steady state is reached.

The achieved 45% reduction in  $E_t$  is not the maximum possible for the systems evaluated. To compute a maximum, future hydraulic modeling efforts can be linked to management models to optimize pumping scenarios (see for example Maddock, 1973 and Aguado and Remson, 1980).

#### CONCLUSIONS

The positive results of this analysis will hopefully encourage continued research into managing water table positions in phreatophyte-floodplain systems as a feasible method of water resource conservation.

Clearly the nature of the  $E_t/D$  relationship needs to be better defined. In situ measurements of phreatophyte response to altered water table posi-

tions including  $E_t$  rate, canopy response, and root depth changes are crucial to understanding the feasibility of this approach. Unfortunately, despite the tremendous effort in past phreatophyte research, this still remains a complex and expensive proposition. New advances in remote sensing of  $E_t$  (Reginato et al., 1985) and in psychrometric methods (Gay, 1979) might prove useful for  $E_t$  measurements.

A survey of classifications of riparian-phreatophyte communities has shown that the variation in them in the Southwest is relatively small (see for example Campbell, 1970; Marks, 1950; or Haase, 1972). Ideally, a distinct  $E_t/D$  relationship could be defined for each community, or perhaps a small number of curves for each as they vary with climate or elevation.

#### LITERATURE CITED

- Affleck, R.S. 1975. Potential for water yield improvement in Arizona through riparian vegetation management. 238 p. PhD dissertation, University of Arizona.
- Aguado, E., and I. Remson. 1980. Ground-water management with fixed changes. J. Water Resources Planning Management Div., Am. Soc. Civ. Eng. 106(WR2):375-382.
- Arizona Department of Water Resources. 1980. (Oct.) Colorado River operation and supply studies. [unpublished report]
- Bouwer, H. 1975. Predicting reduction in water losses from open channels by phreatophyte control. Water Resources Research, 2(1):96-101.
- Bureau of Reclamation. 1973. Progress report - phreatophyte investigation - Bernardo evapotranspirometers. 33 p. Middle Rio Grande Project Office.
- Campbell, C.J. 1970. Ecological implications of riparian vegetation management. J. Soil Water Conservation. 25:49-52.
- Campbell, M.D, and J.H. Lehr, 1983, Water Well Technology. McGraw-Hill. p. 325.
- Cramer, S.F. 1952. Activities of the South Pacific Division, Corps of Engineers, in eradication and control of phreatophytes. Trans. Amer. Geophys. Union. 33(1):77-80.
- Culler, R.C., et al. 1982. Evapotranspiration before and after clearing phreatophytes, Gila River floodplain, Graham Co., Arizona. 67 p.

Table 3.--Computed energy requirements and costs based on the eight-well scenario

$\alpha, C =$	1.5, 3.5				4, 2.5	
	1.8	1.8	2.2	2.2	1.8	2.2
Pump rate (ft <sup>3</sup> /s)						
Duration	1 yr	9.13 yrs (steady-state)	1 yr	60.9 yrs (steady-state)	1 yr (steady-state)	1 yr (steady-state)
KW-HR/YR-PUMP:	92375	93051	154071	158129	86102	135990
\$/YR-PUMP:	7390	7444	12326	12650	6888	10879
\$/AF:	35.89	35.42	47.99	47.52	19.71	26.16

- U.S. Geological Survey Professional Paper No. 655-P.
- Davenport, et al. 1978. Factors influencing usefulness of antitranspirants as applied on phreatophytes. 181 p. Water Resources Center, University of California, Davis. Contribution No. 176.
- Douglas, Ernie. 1954. Phreatophytes - water hogs of the West. Land Improvement. 1(3):8-12.
- Douglas, Ernie. 1965. Surveyors gather material for war against saltcedar. Arizona Farmer-Ranchman. May 29, 1965.
- Ffolliott, P.F., and D.B. Thorud. 1975. Water yield improvement by vegetative management: focus on Arizona. 1048 pp. Report for Rocky Mt. Forest and Range Experiment Station, University of Arizona School of Renewable Resources.
- Fox, K.M. 1977. Importance of riparian ecosystems: economic considerations. In Symposium on importance, preservation, and management of the riparian habitat. Rocky Mt. Forest and Range Experimental Station, Report RM-43: 19-22.
- Gardner, W.R. 1958. Some steady state solutions of the moisture flow equation with application to evaporation from water tables. Soil Science 85(4):228-232.
- Gary, H.L. 1965. Some site relations in three flood-plain communities in central Arizona. J. of Arizona Acad. of Sci. 3:209-212.
- Gatewood, J.S., T.W. Robinson, B.R. Colby, J.D. Hem and L.C. Halpenny. 1950. Use of water by bottom-land vegetation in lower Safford Valley, Arizona. 210 p. U.S. Geological Survey Water Supply Paper No. 1103.
- Haase, E.F. 1977. Survey of floodplain vegetation along the lower Gila River in southwest Arizona. J. of Arizona Acad. of Sci. 7(2):75-81.
- Hanson, R.L. 1972. Subsurface hydraulics in the area of the Gila River phreatophyte project, Graham Co., Arizona. 27 p. U.S. Geological Professional Paper No. 655-F.
- Hillel, D. 1982. Introduction to Soil Physics. Academic Press.
- Horton, J.S. 1973. Evapotranspiration and water research as related to riparian and phreatophyte management - an abstract bibliography. 192 p. U.S. Dept. of Agriculture, Forest Service Misc. Publication 1234.
- Horton, J. S. 1976. Management of moist-site vegetation for water. 41 p. Pacific South-west Interagency Committee Contract Report. U. S. Bureau of Reclamation, Denver. GPO 833:655.
- Humphrys, C. R. 1962. Evapotranspiration bibliography. 33 p. Michigan State University Agricultural Experiment Station Water Bulletin No. 7
- Koogler, J.G. 1952. Phreatophyte control on irrigation projects in New Mexico. Trans. Am. Geophysical Union. 33(1):74-77.
- Maddock, T. III. 1972. Algebraic technological function from a simulation model. Water Resources Res. 8(1)129-134.
- Marks, J.B. 1950. Vegetation and soil relations in Colorado desert. Ecology 31(2):176-193.
- Meinzer, O.E. 1923. Outline of ground-water hydrology, with definitions. 71 p. U.S. Geological Survey Water Supply Paper No. 494.
- Meinzer, O.E., ed. 1927. Plants as indicators of ground water. 95 p. U.S. Geological Survey Water Supply Paper No. 577.
- Merkel, D.L. and Hopkins, H.H. 1957. Life history of saltcedar (*Tamarix gallica* L.). Kansas Acad. Sci. Trans. 60(4):366-369.
- Reginato, R.J., R.D. Jackson and P.J. Pinter Jr. 1985. Evapotranspiration calculated from remote multispectral and ground station meteorological data. Remote Sensing of Environment. [in press, January].
- Robinson, T.W. 1952. Phreatophytes and their relation to water in western United States. Trans. Amer. Geophysical Union 33(1):57-61.
- Robinson, T.W. 1952. Water thieves. Chemurgic Digest October:12-15.
- Robinson, T.W. 1958. Phreatophytes. 84 p. U.S. Geological Survey Water Supply Paper No. 1423.
- Robinson, T.W. and A. I. Johnson. 1961. Selected bibliography on evaporation and transpiration. 25 p. U.S. Geological Survey Water Supply Paper No. 1539-R.
- Robinson, T.W. 1964. Phreatophyte research in the western states March 1969 to July 1964. 31 p. U.S. Geological Survey Circular No. 495.
- Robinson, T.W. 1965. Introduction, spread and areal extent of saltcedar (*Tamarix*) in the western states. 12 p. U.S. Geological Survey Professional Publication No. 491-A.
- Sebenik, P.G. and J.L. Thames. 1968. Water consumption by phreatophytes. Progressive Agriculture, March-April:10-11.
- Slayter, R.O. 1967. Plant-water relationships. 366 p. Academic, New York.
- Tomaneck, G.W. and R.L. Ziegler. 1963. Ecological studies of salt cedar. 128 p. Fort Hays Kansas State College.
- Trescott, P.C., Pinder, G. F., and Larson, S.P., 1967. Finite-difference model for aquifer simulation in two dimensions with results of numerical experiments; U.S. Geol. Surv., Techniques of Water Resources Investigations Book 7, Chapter kC1, 116 p.76.
- Turner, R.M. Quantitative and historical evidence of vegetation changes along the upper Gila River, Arizona. 1974. U.S. Geological Survey Professional Paper No. 655-H.
- U.S. Information Service. 1965. U.S. combats water-stealing plants. U.S. Govt. press release. Washington, D.C.
- Van Hylckama, T.E.A. 1974. Water use by salt cedar as measured by the water budget method. 30 p. U.S. Geological Survey Professional Paper No. 491-E.
- Van Hylckama, T.E.A. 1982. Weather and evapotranspiration studies in a saltcedar thicket, Arizona. 78 p. U.S. Geological Survey Professional Paper No. 491-F.



# Methods for Determining Effects of Controlled Dewatering of Shallow Aquifers on Desert Phreatophytes in Owens Valley, California<sup>1</sup>

Peter D. Dileanis, Farrel A. Branson, and Stephen K. Sorenson<sup>2</sup>

Abstract.--The ability of phreatophytic plants to tolerate and survive dewatering of shallow aquifers is being tested. At test sites that have been equipped with pumping wells, soil moisture and plant physiological responses are being measured as water levels decline.

## INTRODUCTION

The U.S. Geological Survey is currently conducting research concerning the possible effects of ground-water withdrawal on native phreatophytic vegetation in Owens Valley, Calif. The project is being done in cooperation with Inyo County and the Los Angeles Department of Water and Power. This paper describes the methods used to measure the plant's ability to survive changes in water availability brought about by lowering ground-water levels due to pumping.

Owens Valley is situated between the Sierra Nevada and the White and Inyo Mountains (fig. 1). The relatively flat valley floor is about 100 miles long and ranges in elevation from about 3,600 to 4,100 feet. Mountains along the east and west sides of the valley rise 3,000 to 10,000 feet from the valley floor. Owens Valley receives an average of only 5 inches annual precipitation due to the rain shadow east of the Sierra Nevada. Despite little precipitation, ground water is plentiful in the valley. Runoff from the Sierra Nevada snowpack percolates through the unconsolidated alluvial deposits along the valley margins, and supplies most of the recharge to the ground-water system. The water table across much of the valley floor ranges from land surface to about 12 feet below land surface. Ground water is within reach of the roots of phreatophytic shrubs and grasses that dominate the valley floor's plant communities. Phreatophytes are plants that habitually rely on ground water by growing roots down near the water table where capillary water is readily available (Meinzer, 1927). The phreatophytic plants being tested are: nevada saltbush (*Atriplex torreyi*), greasewood (*Sarcobatus vermiculatus*), rubber rabbitbrush

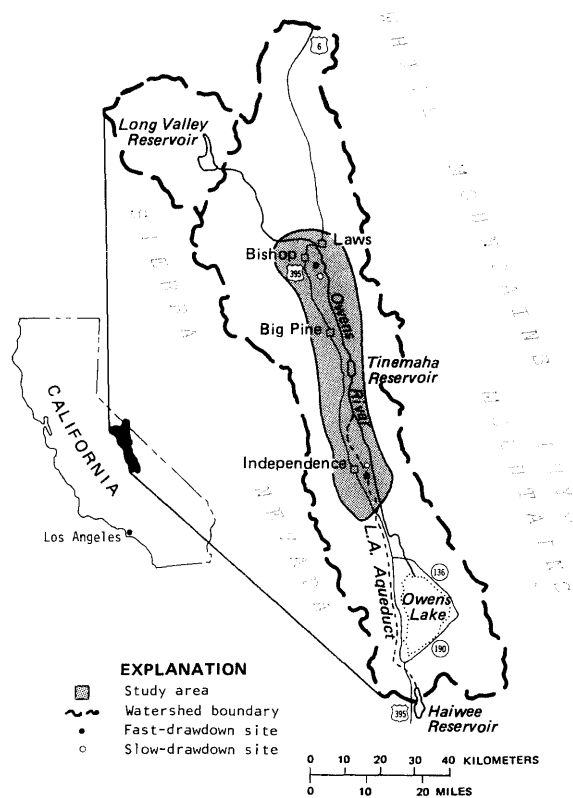

Figure 1.--Location of study area.

(*Chrysothamnus nauseosus*), shadscale (*Atriplex confertifolia*), and big sage (*Artemisia tridentata*). Two of the plants under study, big sage (*Artemisia tridentata*) and shadscale (*Atriplex confertifolia*), while not generally considered to be phreatophytes, are thought to be using ground water in the shallow ground-water areas of Owens Valley. These plants continuing survival on the valley floor may, therefore, be dependent on ground-water availability.

In the early 1900's, the rapidly growing city of Los Angeles, more than 200 miles south, looked to Owens Valley as a long-term plentiful

<sup>1</sup>Paper presented at the North American Riparian Conference, [University of Arizona, Tucson, AZ, April 16-18, 1985].

<sup>2</sup>Peter D. Dileanis and Stephen K. Sorenson are Hydrologists, U.S. Geological Survey, WRD, Sacramento, CA. Farrel A. Branson is a Botanist, U.S. Geological Survey, WRD, Denver, CO.

supply of water. The city bought most of the land in Owens Valley, and in 1913, an aqueduct was completed which diverted surface water from Owens Valley to Los Angeles. In addition, a series of wells was drilled to supply ground water to the aqueduct during periods of low surface-water runoff. Subsequent extensions of the original aqueduct and construction of a second aqueduct, completed in 1970, have increased the amount of water being diverted.

A cooperative project between the U.S. Geological Survey, Inyo County, and the Los Angeles Department of Water and Power began in 1983. The overall objective of this project is to develop mathematical models that would be capable of testing various strategies of ground-water withdrawal designed to mitigate possible impacts on the valley's vegetation. This project has several major components including two- and three-dimensional ground-water-flow models, one-dimensional soil-water-evapotranspiration model, and the controlled drawdown studies described in this paper. All of these components will be integrated into a management/optimization model which will assist Inyo County and the Los Angeles Department of Water and Power to effectively manage the ground-water resources of Owens Valley. Investigation methods being developed for use in this study, and particularly the information obtained concerning vegetation responses to water-table drawdown, will be useful in other areas of the Western United States where the need for water by growing population centers conflict with other uses of available water resources.

#### DESCRIPTION OF TEST SITES

Two types of test sites were established, each designed to investigate different aspects of water-deficit stress caused by controlled de-watering. One type, called a fast-drawdown site, is designed to rapidly lower the ground-water level 25 to 30 feet by pumping from a small cluster of wells. This pumping results in a cone of depression in the water table. Sampling stations are 125-foot transects, located at increasing distances away from the wells (fig. 2). Observation wells were drilled adjacent to all sampling stations to monitor ground-water levels. Two fast-drawdown sites were established, the first located about 4 miles south of Bishop, and the second about 3 miles east of Independence (fig. 1). The second type of site, called a slow-drawdown site, is designed to lower water tables in annual increments of about 6 feet. A constant water table level is maintained under the test sites by pumping the six wells surrounding the site (fig. 3). A drawdown of about 6 feet was made the first year with an additional 6-foot drawdown scheduled for the end of the 1985 growing season. Two slow-drawdown sites were established, the first about 3 miles north of the fast-drawdown site near Bishop, and the other about 0.5 mile west of the fast-drawdown site near Independence. All sites are located in typical areas of relatively undisturbed phreatophytic vegetation. Soil

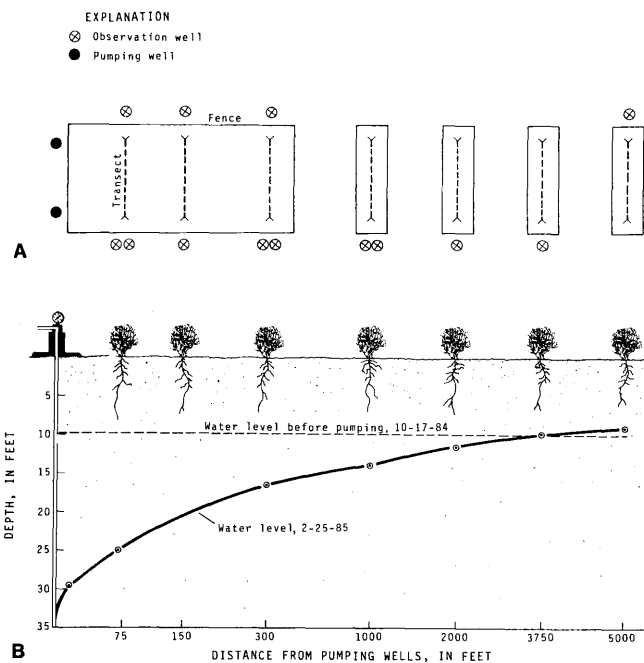

Figure 2.--Fast-drawdown site near Bishop: (A) Areal view showing placement of wells and sampling stations (125-foot transects within fenced enclosures); and (B) cross section showing depth to water as of February 25, 1985.

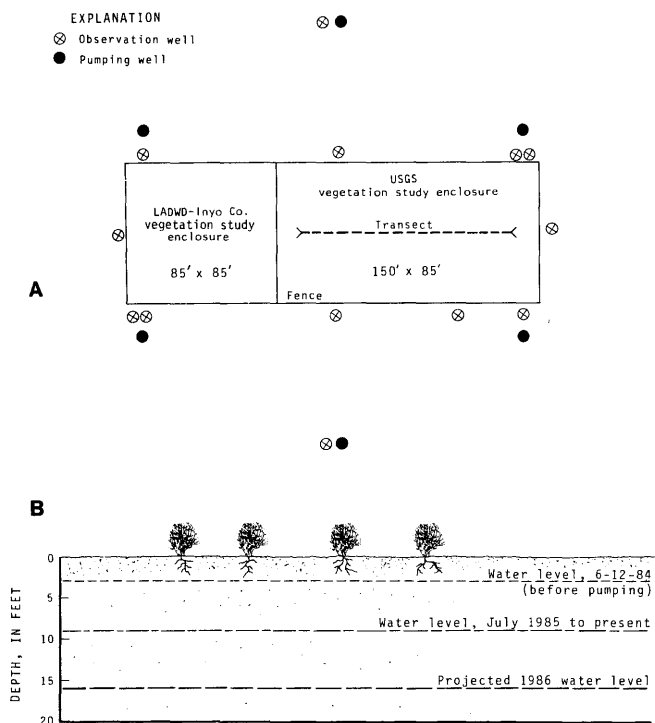

Figure 3.--Slow-drawdown site near Independence: (A) Areal view showing sampling station (125-foot transect within fenced enclosure); (B) cross section showing depth to water.

types are different between the Bishop and Independence area test sites. Variability in soil types was desirable so that plant responses can be linked closely to the variety of soil conditions in the valley.

## METHODS OF INVESTIGATION

As the water level declines below rooting zones of the plants, increasing water-deficit stress is expected to occur. At the fast-drawdown sites, a series of plant stresses is expected to occur, ranging from insignificant changes at control stations farthest from the wells to stress severe enough to cause death to plants at stations closest to the wells. The slow-drawdown sites are testing the ability of the plants to extend roots to a lower water table if water tables are reduced slowly. In order to determine the effects of dewatering on the plants, four methods of investigation are being used.

### Soil Sampling

The survival of plants in a particular location is controlled largely by the physical characteristics of the soil, and by the amount and availability of moisture in the soil. In order to determine soil and soil-moisture characteristics, soil samples are collected monthly from March through October at all transects. The samples are collected using a specially designed, 2-inch diameter hand auger. Successive 10-cm samples are collected from the surface down to near the water table. The samples are put into an air-tight plastic bag along with a 5.5-cm disk of filter paper, sealed in a metal can, and incubated at 20°C for at least 1 week to allow the filter paper to come to moisture equilibrium with the soil. The wet soil and filter paper are weighed, oven dried, and weighed again. Gravimetric soil-moisture content and moisture content of the filter paper are calculated from these weights. Water potential is calculated using the calibration curves of R. F. Miller and F. A. Branson (U.S. Geological Survey, written commun., 1985). Because of the auger barrel design, a reasonably constant volumetric sample is taken each time, making it possible to closely calculate bulk density, void capacity, and volumetric water content of the soil.

Measurements of physical and moisture characteristics of soil are essential in determining soil moisture availability to plants. The amount of water in the soil column, as well as the force with which the soil retains the moisture, determines how much moisture is available to plants and what forces the plant must exert in order to use that moisture. Soil characteristics also are essential to the more applied question of plant survivability with declining water tables. Knowledge of the soil characteristics allows estimates of how much moisture will drain from the soil when water tables decline, and how much remains for plant use. These answers will, in part, determine if the plant will have enough moisture in the newly drained soils to grow deeper roots or whether the amount of water will be so limiting that the plant will not survive.

### Vegetation Transects

Vegetation cover characteristics of the plant community at each site is expected to change as the plants are subjected to increased stress resulting from water table drawdown.

Vegetation cover at each station is measured using the point quadrat method (Goodall, 1952) along each 125-foot linear transect. A linear array of long pins spaced 0.5 foot apart are held in a frame above the plant canopy and perpendicular to the ground. As each pin is lowered, every object the pin contacts enroute to the ground is recorded in one of the following categories: plant species, non-living plant material (standing or detached mulch), and bare ground. The point frame is moved along the entire length of the transect. A summary of all the first contacts made by all pins is used to estimate the percentage of cover of the individual species and plant community at each transect. Records of all pin contacts give estimates of leaf density and cover repetition.

### Plant Growth and Phenology

Water-deficit stress may affect the growth and development of plants. At each station, a representative plant of each of the dominant shrub species has been selected and three branches were labeled with color coded wire. Terminal growth on these branches is measured biweekly or monthly throughout the growing season. In stressed plants, less metabolic energy is available for vegetative growth, resulting in lower growth rates. The phenology of the marked plants is observed and recorded at the same time growth measurements are made. For this study, 10 phenological stages are recognized from beginning leaf growth through dormancy.

### Xylem Water Potential

Negative water potentials occur in the xylem, or water conducting tissues, of vascular plants when loss of water by transpiration through the stems and leaves becomes greater than water gained from absorption by roots. As water is depleted from the soil, the water potential gradient between soil, plant, and atmosphere increases resulting in lower potentials for the water moving through the plant.

Measurements of xylem water potential are made monthly during the growing season to document water-deficit stress and to determine the minimum water potentials the plants can tolerate. In 1984, measurements were made at midday when water potentials are normally at their minimum. In 1985, additional measurements will be made before dawn when water potentials are at their maximum. These measurements will define the range of water-deficit stress the plants experience throughout their diurnal cycle.

Xylem water potential is measured using a pressure bomb (Ritchie and Hinckley, 1975). A small leafy branch is cut from the plant and sealed in a chamber with the cut end of the stem protruding from a gas-tight rubber stopper. Pressurized air is metered into the chamber until fluid appears at the surface of the cut stem. The positive pressure that is needed to force fluid back to the end of the branch in the pressure bomb is equal in number, but opposite in sign, to the negative pressure of potential in the xylem at the time the branch was cut.

#### SUMMARY

By lowering water-table elevations, phreato-phyte plant responses are being studied in relation to moisture availability in the soil. Plant responses are determined by measuring species population, vegetation cover, plant growth, phenological development, and xylem water potential. The amount and availability of moisture in the soil to plants is determined by measuring volumetric water content and soil-moisture potential.

Data from this study will be used to determine the minimum soil moisture required by the phreatophytes and will be used in conjunction with ground-water-flow models being developed by the U.S. Geological Survey. These models will estimate the effects of ground-water withdrawal on plant survivability which can be used to

assist in the effective management of the ground-water resources in Owens Valley.

#### LITERATURE CITED

- Goodall, D. W. 1952. Some consideration in the use of point quadrats for analysis of vegetation. Australian Journal of Scientific Research Series B-Biological Sciences, v. 5, p. 1-41.
- Meinzer, O. E. 1927. Plants as indicators of ground water. U.S. Geological Survey Water-Supply Paper 577, 95 p.
- Ritchie, G. A., and T. M. Hinkley. 1975. The pressure chamber as an instrument for ecological research. Advances in Ecological Research 9: p. 165-254.

# Multiple Regression Analysis for Evaluating Non-Point Source Contributions to Water Quality in the Green River, Wyoming<sup>1</sup>

Timothy E. Fannin, Michael Parker, and Timothy J. Maret<sup>2</sup>

**Abstract.**--The Green River drains 12,000 mi<sup>2</sup> of western Wyoming and northern Utah. The basin incorporates a diverse spectrum of geology, topography, soils, and climate. Land use is predominately range and forest, though an increasing number of industries are locating in the southern half of the drainage. We report on the application of a multiple regression model used to associate various riparian and non-riparian basin attributes (geologic substrate, land use, channel slope, etc.) with previous measurements of phosphorus, nitrate, and dissolved solids in the Green River system. We propose possible reasons for such significant water quality/basin attribute associations, and explain some of the advantages and disadvantages of using such a technique to explore those associations in a large western watershed.

## INTRODUCTION

The Green River basin of western Wyoming and northern Utah is a climatologically, topographically, and geologically diverse watershed. Mean temperatures range from -6°F (-21°C) to 86°F (30°C); mean precipitation varies from 11" (28cm) to 41" (104cm), with the latter figure typical for the surrounding mountains. The major vegetative cover in the drainage is range and forest (table 1).

Table 1.--Land cover by percentage of total basin area in the Green River and Blacks Fork sections (see figure 1) of the Green River Basin.

Land cover type	Green River section	Blacks Fork section
Alpine	2	0
Irrigated crops	6	7
Rock or dunes	1	3
Wetlands	1	1
Urban	<1	<1
Range	73	67
Forest	16	20
Total	100	100
Area (mi <sup>2</sup> )	9500	2920

<sup>1</sup>Paper presented at the first North American Riparian Conference. [The University of Arizona, Tucson, AZ, April 16-18, 1985].

<sup>2</sup>Timothy E. Fannin and Timothy J. Maret are graduate students, and Michael Parker is Associate Professor, in the Department of Zoology and Physiology, University of Wyoming, Laramie, WY.

This paper is based upon research conducted under a grant from the Wyoming Water Research Center, Laramie, WY.

Not surprisingly, the area is used by man predominantly for grazing and forestry. Sparsely inhabited, (the population of the study area is only about 52300 people, U.S. Bureau of the Census 1981), other land uses are mining of trona (sodium carbonate) and farming two major areas of irrigated cropland.

The basin topographically is a mixture of extensive flats and rolling hills surrounded on three sides by mountains (fig. 1) which have a maximum

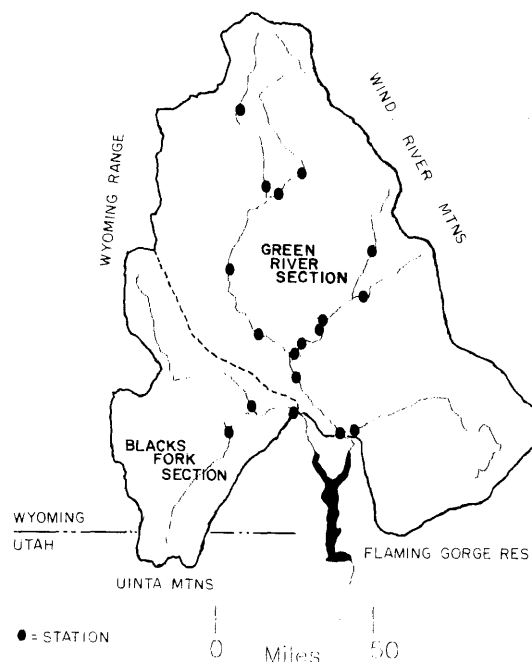

Figure 1.--Outline map of the study area showing water quality/discharge stations, major streams and the Green River and Blacks Fork Sections of the drainage.

elevation of 13804 feet (4207m). Mean elevation is 7416 feet (2260m). Sixty percent of the drainage is underlain by Tertiary formations, and extensive areas of Green River shale.

Though poor water quality has not been a problem in the upper reaches of the basin, the lower reach of the Green River shows a large increase in salinity load as dissolved solids (DeLong 1977). Flaming Gorge Reservoir, immediately downstream of our study area shows sporadic, though increasingly severe, summer eutrophication which has affected adversely both fishing and body-contact recreation (U.S. Environmental Protection Agency 1977, Southwestern Wyoming Water Quality Planning Association 1978, Fannin 1983, Parker, et al. 1984). The low human population density, few industries or facilities requiring surface water discharge permits (Wagner 1984), and relatively high proportion of agricultural land use support the observation that non-point sources are responsible for 88% of the phosphorus input to Flaming Gorge Reservoir (Southwestern Wyoming Water Quality Planning Association 1978).

No systematic basin-wide investigation of the origin of dissolved and suspended substances in the Green River has yet been done. Such a study would be quite useful as a baseline study, both in the accumulation and organization of existing data about water quality and its sources, and in relating present associations of water quality to basin characteristics. Practical applications of such knowledge would be apportioning loadings to a specific source area of the drainage, predicting changes in water quality from changes in basin characteristics such as land use, or investigating if associations of water quality with basin characteristics change with time.

Perhaps one of the reasons such a basin-wide investigation has not been done is the sheer size of the area. However, Lystrom, et al. (1978) proposed and used a multiple regression modeling approach to associate various basin parameters with water quality in the 27,510 mi<sup>2</sup> Susquehanna River watershed. We report here the results of an investigation of the association of watershed characteristics with water quality in the Green River basin of Wyoming and Utah, using a similar multiple regression technique.

The objectives of this project are to:

- 1) associate attributes of the Green River watershed with water quality in the Green River system using multiple regression. A prerequisite to this objective is the collection and organization of water quality data and information about the basin which could conceivably affect water quality.
- 2) estimate water quality changes in Flaming Gorge Reservoir which may be associated with upstream basin characteristics.
- 3) achieve these objectives by analyzing data existing in published records, reports, papers, and maps. No field work is required.

In this paper, we will:

- 1) demonstrate and document our application of multiple regression to associate water quality with attributes of the Green River basin.
- 2) Propose possible causes of such significant water quality/basin attribute associations.
- 3) Discuss the general advantages and disadvantages of using multiple regression techniques to model water quality in the basin.

In conducting this research we assumed that water quality is indeed a function of physical, chemical and biological characteristics of the drainage, that multiple regression is suited for associating such characteristics with water quality, and that non-point sources are paramount in determining water quality in the watershed.

## MATERIALS AND METHODS

### Regression Models

Multiple linear regression describes variation of a single dependent variable as a function of variations in several independent variables. In this case, a single water quality parameter is the dependent variable, and its variation is accounted for by the variation in two or more independent variables of physical, chemical, or biological basin characteristics. The general equation (from Edwards 1979) is:

$$Y' = a + b_1X_1 + b_2X_2 + \dots + b_kX_k$$

where Y' is the dependent variable, X's are the independent variables, k the number of independent variables in the equation, and a is the regression constant. By choosing appropriate independent variables (basin parameters), we seek to maximize the correlation between the predicted value of our water quality variable and the actual value of the variable. The basis of our choice of independent variables derives from an interpretation of results from an SPSS (Nie, et al. 1975) multiple regression program, as detailed in Regression, below.

### Independent Variables

In this paper, we've defined an independent variables as the unique numerical measure of some feature of the drainage basin. The five major types of independent variables (also referred to as "basin attributes"), detailed in table 2, roughly correspond to those of Lystrom, et al., but the individual attributes within each of our categories were dictated by the data available for the Green River basin.

Much of the data from which we derived basin attributes had to be transformed from maps, charts, or lists. We used a COMPAQ microcomputer with a Houston Instruments 11"x11" digitizer to measure areas from maps, and the LOTUS 123 software (Lotus Development Corporation 1983) to store and manipulate collected information. Sources of information and a description of their transformation into independent variables follow.

Table 2.--Major categories of basin attributes for the Green River drainage, the number of variables originally within each category, and some examples of independent variables from each category.

Basin attribute category	Number of variables	Examples
GEOLOGY	51	Glacial area Tipton shale area Area of Precambrian rock
SOILS	19	Soil pH K factor
CLIMATE	3	Mean minimum temp
LAND COVER/LAND USE	75	Area juniper % area of juniper Total range area
HYDROLOGY	16	Bifurcation ratio Total stream length 10 year flood cfs
Number of variables	164	

#### Geology

We calculated areas of all geological formations shown on three hydrologic investigations maps (Welder and McGreevy 1966, Whitcomb and Lowry 1968, and Welder 1968). The area of each formation in each of 18 subbasins (see Dependent Variables) were recorded and areas of geologically similar formations summed as independent variables.

#### Soils

From Young and Singleton (1977) we found which soil series were represented in soil associations in the watershed and the area of each association in each subbasin. From corresponding soil series data sheets supplied by Munn (1984), we calculated and weighted the characteristics of all soil series within each association by area to obtain the subbasin values.

#### Climate

Maps from Lowers (1960) were enlarged and minimum-maximum temperatures, weighted by area, calculated for each subbasin.

#### Land Cover/Land Use

Anderson et al. (1984) compiled a land cover map of Wyoming from which we obtained values of cover, weighted by area, for each subbasin.

#### Hydrology

Hydrological variables were estimated using data taken from U.S. Geological Survey 1:250,000 scale topographic maps of the basin. Areas were obtained with the digitizer, and linear measures with a map measuring wheel. Transformations and calculations were performed within Lotus spreadsheet files.

#### Reduction of Number of Independent Variables

We reduced the number of independent variables from the original 164 by first eliminating variables which were percentages or sums of other variables (except for Geological variables, where we kept the sums and eliminated their components). We make a further reduction in the number of variables by dropping variables which were not significantly related to a water quality variable ( $p=0.05$ ) in a simple bivariate regression. Thus, for every dependent water quality variable, we had a unique set of independent basin attributes for the multiple regression analysis.

#### Dependent Variables

The Wyoming Water Research Center maintains a copy of the U.S. Geological Survey's surface water quality and discharge data for Wyoming. From this we extracted all water quality data for all sampling stations in the watershed. We selected stations with the greatest number of acceptable water quality parameters. A water quality parameter was acceptable if it had at least seven years of data between water years 1965 (when Flaming Gorge Reservoir's dam closed) and 1979, with at least one year of data comprised of ten or more samples. Using these criteria, we found only eight water quality variables for at each of eighteen stations. The areas above these eighteen stations also defined the subbasins for which we compiled basin attribute values.

The concentration of many water quality parameters depends upon discharge (Lystrom, et al.). For these parameters, mean loads should be calculated as the sum of instantaneous loads derived from the concentration/discharge relationship. For the parameters considered in this report [phosphorus (P), nitrate nitrogen ( $\text{NO}_3$ ), and total dissolved solids (TDS)], only TDS concentration showed such a significant relation. We therefore used TDS loads, and phosphorus and nitrate concentrations as our dependent variables in the multiple regression analyses.

#### Regression

Each of the three water quality parameters had a unique set of associated independent variables. A Pearson correlation analysis (Nie, et al. 1975) was used to investigate intercorrelations among the independent variables prior to the regression analysis. For the regression method we chose Hull and Nie's (1981) stepwise NEW REGRESSION, with probabilities of F-to-enter and F-to-remove at default values of 0.05 and 0.10 respectively. All SPSS analyses were conducted on a Control Data Corporation Cyber 760 computer.

Our interpretation of regression results to find the "best" association of water quality with basin attributes hinged on two objective criteria and one somewhat philosophical principle. Our first criterion was that a good regression equation explains the most of the variance about the dependent variable (i.e., has a higher adjusted  $R^2$ ), and

has a lower measure of error (in this case, a lower residual mean square) than would an equation with a poorer fit. Our second criterion was that the equation minimize combinations of strongly interacting independent variables, as defined by a correlation of  $r^2 > 0.60$ .

Given these criteria, we tempered their strict application by the philosophy that "a relationship may be statistically significant without being substantively important" (Milliken and Johnson 1984). Lystrom, et al. also chose their best models based on other-than-statistical criteria; that is, "conceptual knowledge of the water-quality process." In other words, if a regression was best statistically, but we could find no conceptual reason for the association of its basin attributes with water quality, we chose a statistically less good but conceptually more sensible model.

## RESULTS

From 18 subbasin values for each of a selected set of basin attributes, and eighteen values of three water quality parameters taken one at a time, we obtained three regression models with significant and conceptually acceptable relations between the attributes and the parameter (table 3).

Table 3.--Multiple-regression models of basin attributes associated with water quality in the Green River basin.

REGRESSION EQUATION	$\frac{\text{ADJUSTED } R^2}{\text{RESIDUAL MEAN SQUARE}}$ # ATTRIBUTES CONSIDERED
PHOSPHORUS CONCENTRATION (mg/l) = -0.144 + 0.563(K FACTOR) + 0.0393(FLOOD RATIO)	0.978/0.000/24
NITRATE CONCENTRATION(mg/l) = -2.30 + 2.71(FLOOD RATIO) + 0.0043(CRETACEOUS ROCK [mi <sup>2</sup> ])	0.893/0.442/5
TDS LOAD (tons/year) = 9730 + 36.5(TOTAL LENGTH OF CHANNELS [mi]) + 493(IRRIGATED CROPLAND [mi <sup>2</sup> ]) + 135(MIXED RANGELAND [mi <sup>2</sup> ])	0.993/2.21x10 <sup>8</sup> /27

In table 3, FLOOD RATIO is the quotient of the average 10-year flood divided by the maximum discharge recorded for the study period (water years 1965 to 1979). The 5 attributes considered for the nitrate concentration model are a nonintercorrelated subset of an original set of 16 attributes, containing some highly intercorrelated members ( $r^2 > 0.60$ ).

The results of the regression analyses illustrate the application of our criteria for acceptance of a regression model. PHOSPHORUS CONCENTRATION had a relatively low intercorrelation ratio (0.323), and the variables first selected by the regression analysis made sense conceptually. (The

intercorrelation ratio is the number of attribute significant correlations [ $r^2 > 0.60$ ] divided by the number of interactions in the correlation matrix.) TDS LOAD, on the other hand, had a high intercorrelation ratio (0.567), but since the variables first selected by the analysis, which implies that they were statistically best, also were conceptually related to TDS, we accepted this model as best. TOTAL LENGTH OF CHANNELS is, however, correlated with IRRIGATED CROPLAND ( $R^2=0.74$ ), so some caution should be used when applying this model.

NITRATE CONCENTRATION illustrates conceptual acceptability over statistical significance. The intercorrelation ratio was comparable to that of PHOSPHORUS CONCENTRATION, but the initial, or best statistical, regression analysis yielded MEAN JULY MAXIMUM TEMPERATURE as the only significant associated attribute. Because we could think of no process associating temperature with NITRATE CONCENTRATION in the basin, we sequentially removed intercorrelated variables and continued regression analyses after each deletion. The best regression we found then, was the one in a set of conceptually acceptable models which had the highest adjusted  $R^2$ , and lowest residual mean square.

## DISCUSSION

### Green River Regression Models

The PHOSPHORUS CONCENTRATION model is conceptually acceptable because phosphorus (as total phosphorus, measured by the U.S. Geological Survey) is associated with particulate matter in streams. Since K FACTOR is a measure of soil erodability, and FLOOD RATIO and estimate of flooding intensity, we may expect that an increase of either or them could be associated with an increase in particulates and therefore total phosphorus in streams.

For NITRATE CONCENTRATION, positive association of a geologic variable (CRETACEOUS ROCK) and an estimate of flood intensity (FLOOD RATIO) with dissolved nitrate in a river would be expected if the Cretaceous rock bears minerals high in nitrate or perhaps other nitrogenous compounds. The predictors and their relationship to nitrate concentration are therefore conceptually acceptable, although we have not yet investigated whether the mineral components of the Cretaceous rock formations in the subbasins are in fact nitrogenous.

The TDS LOAD model was the only model incorporating land use parameters as predictors of water quality. A positive association of TDS with irrigated cropland is not unexpected, since TDS increases from 223 mg/l (3359 tons/year) above an irrigated area on the Big Sandy River to 2630 mg/l (147,000 tons/year) below it. A disturbed MIXED RANGELAND also could increase TDS LOAD if infiltration increased as a result of reduced plant cover. Increases in TOTAL LENGTH OF CHANNELS may imply an increased chance of infiltrating precipitation being captured by a stream and measured in a sample rather than being "lost" to deeper groundwater.

### Application of the Techniques

There are several advantages in applying multi-



iple regression techniques to water quality data from the Green River basin. First, since existing data were on hand or readily available from published sources, no field work was required, reducing costs. This is not a trivial advantage considering the large basin area.

Secondly, from the results of the multiple regression analyses, we have a smaller set of basin parameters to investigate if we wish to determine cause-effect relations between attributes of the drainage and water quality. Multiple regression is an associative technique; simply because an attribute is associated with a water quality parameter does not mean that a change in the attribute will necessarily cause a change in the parameter. This nomination of important parameters is also a non-trivial advantage given that we found, from existing data, 164 basin attributes.

Thirdly, if we assume a cause-effect relationship between basin attributes and water quality, and if the models have been tested and verified, we may use them to predict changes in water quality from changes in the basin attributes. This is not useful for relatively non-static basin attributes. The area of the drainage underlain by Cretaceous rock is not as likely to change as the area under different land cover. We must note that the three models we propose have not yet been tested or verified; they should not be used as predictive equations.

Finally, the water quality database for the portion of the Green River basin we studied was, compared by Lystrom et al., very sparse. In order to get 18 stations, two less than the minimum they recommend, we had to liberalize our criteria of choice twice. We increased the temporal width of the study from 10 years to 15, and reduced the proportion of years for which we required at least one data point from 10 to 7. Lystrom, et al. also extrapolated the data from a single year with at least 10 seasonally spaced samples to their entire 10-year study. In the arid and semi-arid West, where year-to-year variation in precipitation can be significant, we did not feel that extrapolating a single year of data to the entire study period was wise. We feel that the scarcity of water quality data found in this study would be typical of other western drainages with low human population densities and little cropland agriculture.

#### LITERATURE CITED

- Anderson, S.H., and D.B. Inkely. 1984. Wyoming land cover map. Wyoming Cooperative Fish and Wildlife Unit, University of Wyoming, Laramie, WY.
- DeLong, Lewis L. 1977. An analysis of salinity in streams of the Green River basin, Wyoming. U.S. Geological Survey Water-Resources Investigations #77-103. 32pp. USGS Water Resources Division, Cheyenne, WY.
- Edwards, Allen L. 1979. Multiple regression and the analysis of variance and covariance. 212 pp. W.H. Freeman and Co., San Francisco, CA.
- Fannin, Timothy E. 1983. Wyoming lake classification and survey, volume 1. 226pp. Wyoming Game and Fish Department, Cheyenne, WY.
- Hull, C. Hadlai, and Norman H. Nie. 1981. SPSS update 7-9: new procedures and facilities for releases 7-9. 402pp. McGraw-Hill Book Company, New York, NY.
- Lowers, A.R., 1960. Climate of Wyoming. Climatology of the United States #60-48. U.S. Department of Commerce, Washington, DC.
- Lotus Development Corporation. 1983. Lotus 123. Lotus Development Corporation, Cambridge, MA.
- Lystrom, David J., Frank A. Rinella, David A. Rickert, and Lisa Zimmerman. 1978. Multiple regression modeling approach for regional water quality management. EPA-600/7-78-198. 60pp. Environmental Research Laboratory, Athens, GA.
- Milliken, George A. and Dallas E. Johnson. 1984. The analysis of messy data, volume 1: designed experiments. 473pp. Lifetime Learning Publications, Belmont, CA.
- Munn, Larry. 1984. Personal correspondence. Department of Plant Science, University of Wyoming, Laramie, WY.
- Nie, Norman H., C. Hadlai Hull, Jean G. Jenkins, Karin Steinbrenner, and Dale H. Brent. 1975. SPSS: statistical package for the social sciences. 675pp. McGraw-Hill Book Company, New York, NY.
- Parker, Michael, Wayne A. Hubert, and Steve Greb. 1984. A preliminary assessment of eutrophication in Flaming Gorge Reservoir, Denise Bierley, ed. 46pp.+app. Wyoming Water Development Commission, Cheyenne, WY, and Wyoming Water Research Center, Laramie, WY.
- Southwestern Wyoming Water Quality Planning Association. 1978. Clean water report for southwestern Wyoming, 313pp. CH2M Hill, Denver, CO.
- U.S. Environmental Protection Agency. 1977. Report on Flaming Gorge Reservoir, Sweetwater County, Wyoming and Daggett County, Utah, EPA Region VIII. National Eutrophication Survey Working Paper #885.
- U.S. Bureau of the Census. 1981. 1980 census of the population; vol. 1: characteristics of the population; chapter A: number of inhabitants, part 52 Wyoming. PC80-11-A52. U.S. Bureau of the Census, Washington, DC.
- Wagner, John. 1984. Personal correspondence. Wyoming Department of Environmental Quality, Cheyenne, WY.
- Welder, George E. 1968. Ground-water reconnaissance of the Green River basin--southwestern Wyoming. Hydrologic Investigations Atlas HA-290. U.S. Geological Survey, Washington, DC.
- \_\_\_\_\_, and Laurence J. McGreevy. 1966. Ground-water reconnaissance of the Great Divide and Washakie basins and some adjacent areas, southwestern Wyoming. Hydrologic Investigations Atlas HA-219, reprinted 1981. U.S. Geological Survey, Washington, DC.
- Whitcomb, Harold A. and Martin E. Lowry. 1968. Ground-water resources and geology of the Wind River basin area, central Wyoming. Hydrologic Investigations Atlas HA-270. U.S. Geological Survey, Washington, DC.

# Increasing Summer Flow in Small Streams Through Management of Riparian Areas and Adjacent Vegetation: A Synthesis<sup>1</sup>

D. Frederic Stabler<sup>2</sup>

---

Abstract.--Construction of small dams, suppression of woody vegetation in and adjacent to riparian zones, and removal of livestock from streambanks have all led to summer streamflow increase. Potential may exist to manage small valley bottoms for summer flow increase, while maintaining or improving riparian habitat, range and watershed values.

---

## INTRODUCTION

Techniques to increase streamflows through treatments in phreatophyte (i.e. riparian) zones depend almost exclusively on reducing evapotranspiration during the growing season (Satterlund 1972). At present, phreatophyte control to improve water yield has largely been abandoned, as a result of smaller than expected water savings and poor benefit/cost ratios stemming in part from potential loss of high-value riparian habitat (Graf 1980). Watershed and habitat improvement projects within riparian zones are, however, occasionally reported to increase summer streamflows without employing evapotranspiration control methods (Heede 1977, Jester and McKirdy 1966). Are there alternatives to currently accepted techniques? In an attempt to answer this question, this paper reports and interprets the results of a search for information pertaining to activities in or near riparian areas that have resulted in summer streamflow modification.

## METHODS

Conventional literature search methods were used. In addition, researchers and field personnel were contacted to obtain unpublished information.

## INFORMATION REVIEW

Information located relates primarily to small fluctuating streams, orders one through four (Strahler 1957). Three categories of activity were identified which can result in modification of summer streamflows: change in numbers of dams present, changes in vegetation in and near riparian zones, and changes in livestock grazing.

---

<sup>1</sup>Paper presented at the North American Riparian Conference (Tucson, Arizona, April 16-18, 1985).

<sup>2</sup>D. Fred Stabler is the District Fisheries Biologist, Bureau of Land Management, Rawlins, Wyoming.

## Dams

### Beaver Dams

The effects of beaver dams on summer streamflow were observed on a small stream in Massachusetts after beaver, their dams and instream woody debris had been removed (Wilens et al. 1975). In the year beaver were removed, both experimental and control streams maintained perennial flow, but the control stream maintained the higher flow. The following spring, beaver unexpectedly reoccupied the experimental stream and built dams, while the control stream remained free of beaver. During the summer of the same year, the control stream went dry, but flow continued throughout the year at a station below the new dams on the experimental stream.

In a beaver study in Utah (Bates 1963), seepage into the stream in the study area was found to increase in the summer and decrease during the winter months. As a result, water budgets could not be determined with the instrumentation available. Analysis of streamflow data indicated that beaver did not, however, significantly affect overall consumptive use of water during the dry season by building dams and altering adjacent vegetation. Instead, consumptive use was shifted to earlier in the growing season in beaver pond areas, as compared to a stream section without ponds.

Reports of the effects of beaver on streamflow are rare in the literature, but where reported tend to support the idea that beaver ponds augment summer streamflow. Beaver dams constructed after introduction of beaver on Ragg Creek in California in 1938 resulted in a small but steady flow throughout the summer in an area that normally was almost dry by mid-summer, and a similar finding was noted on another California stream (Tappe 1942). Serious economic losses were reported as the result of the loss of beaver on several streams in the Ochoco National Forest in eastern Oregon (Smith 1938, Finley 1937). Trout streams disappeared and hay crops in beaver pond areas were reduced by 90 percent, resulting in a loss at the time of \$30,000 per year. Ranchers were either without recourse or had to drill

wells to water their stock. Downstream, lack of irrigation water resulted in reversion of cultivated land to desert. In Missouri, beaver in headwater streams reportedly restored permanently flowing water with resultant good fishing (Dalke 1947). Literature reviews by Call (1970) and Bates (1963) strongly support the idea that beaver dams help stabilize streamflow regimen and extend flows into the summer months.

Reid (1951) stated that enlarged water surfaces created by beaver dams in an Adirondack spring-fed stream increased evaporation rates and reduced the volume of streamflow by 50 percent. This observation is the only information located suggesting that the activities of beaver can reduce summer streamflow.

#### Check Dams/Gabions

The conversion of streams to perennial flow has been reported as a result of check dam and gabion installation in New Mexico, Oregon, Texas, and Colorado. The best-documented case was in Colorado in the Alkali Creek drainage (Heede 1977). In 1958, the drainage was fenced and cattle were excluded. In 1963, 132 check dams were installed in ephemeral gully networks for erosion control, and disturbed areas were reseeded. In 1967, live-stock were reintroduced at a low stocking rate. In 1970, the rehabilitated gullies unexpectedly developed perennial flow. Old beaver dams exposed in the gully walls were observed during construction of the check dams, and since 1977 beaver have reoccupied a portion of the drainage just below the study area.<sup>3</sup> Precipitation remained normal during the term of the study. Increases in ground cover and new sediment deposits in the gullies were believed to be responsible for change to perennial flow. Willow and rushes had become firmly established by 1977, yet perennial flow continued (Heede 1977).

In the Fremont National Forest in Oregon, the installation of 34 rock check dams on Shoestring Creek in 1974 resulted in perennial flow below a mile-long erosion control project (Anon. 1979). Livestock grazing patterns remained unchanged. Recovery of bank vegetation and use of the water by trout and waterfowl where none had existed for years was reported.

Brown (1963) reported the results of a water conservation program undertaken on the Flat Top Ranch, Texas, in which all major drainages were converted to perennial flow. Dams were constructed to accelerate infiltration into sandy banks. Water storage in banks was also increased by diversion channels to spread water and promote infiltration and storage. Development of upland areas into grasslands, to retard runoff and promote storage, was also undertaken.

---

<sup>3</sup>Heede, Burchard H. 1983. Personal communication. USDA Forest Service, Rocky Mountain Forest and Range Experimental Station, Tempe, Arizona.

In New Mexico, Jester and McKirdy (1966) reported that installation of check dams in Taos Creek resulted in perennial flow within 10 years, and that trout were subsequently stocked in the stream. On another stream, Las Huertas Creek, within three years of installation of 25 gabion structures, streamflows were extended each spring by a month or more. The improved stream section was lightly stocked with trout, and some fishing was provided.

#### Streamside Vegetation

The information reported here has been limited to situations where streamflows have been measured at gaging stations, or where flow changes have been observed in the field, following treatment of valley bottom vegetation. A large part of the literature on water yield improvement via suppression of phreatophytes has involved estimation of potential water savings (Horton and Campbell 1974). Predicted water savings, however, have often been more than actual savings, as determined by field measurement. Few studies meeting the above criteria have been reported (Sopper 1971). No literature was located reporting streamflow modification by use of anti-transpirants in riparian zones.

In a paired-watershed experiment, Rowe (1963) reported that removal of 4 acres of riparian and 34 acres of woodland vegetation along Monroe Canyon, California, resulted in variable but significant water savings that ranged from 0.4 to 1.2 acre-feet per acre treated. Perennial flow from the treated stream section also resulted. The greatest water savings were attributed to removal of peripheral, deep-rooted woodland species that were able to tap the capillary fringe and saturated valley bottom soils through a layer of aerated overburden. The smallest savings in water was thought to occur along the stream channel where free water and wet soil surfaces, within the capillary fringe, were subjected to the direct effects of wind and solar radiation. Evaporation from such areas was estimated to be about the same as evapotranspiration loss from areas with an undisturbed riparian cover.

Ingebo (1971) reported that removal of streamside chaparral from Whitespar B watershed in Arizona resulted in perennial flow from a previously intermittent stream. Water savings ranged from 0.35 to 0.55 acre-feet annually per acre treated.

Rich and Thompson (1974) reported that removal of alder and bigtooth maple adjacent to streams, springs and seeps in the North Fork of Workman Creek drainage in Arizona resulted in no significant changes in water yield during the riparian growing season, and that diurnal fluctuations in streamflow were not changed. Less than one percent of the basal area of trees in the 248 acre watershed were removed from riparian areas. Later, the removal of 80 acres of adjacent nearby moist-site conifer resulted in a 45 percent increase in annual water yield.

Bowie and Kam (1968) reported that after the eradication of cottonwood, willow and seepwillow

along a 1.5 mile section of Cottonwood Wash, Arizona, a water savings amounting to 6 percent over inflow occurred during the growing season. Riparian vegetation was eradicated on 22 acres of floodplain and water savings amounted to 1.7 acre-feet per acre treated. Reduced water savings later in the study were attributed to the reestablishment of seepwillow. Increased evaporation from exposure of riparian soils to wind and sun was postulated as the reason for less than expected savings.

Small increases in dry-season streamflow have been reported after removal of riparian vegetation from streambanks by Dunford and Fletcher (1947) in North Carolina, by Nanni (1972) in South Africa, and by Biswell and Schultz (1958) in California.

Streamflows increased in five small Oregon drainages where juniper cuttings were performed for understory release<sup>4</sup>. Livestock were excluded from the treated drainages. Each drainage was reported to have undergone conversion from a dry, erosive, juniper-dominated valley to one containing a true riparian system. Increased release of groundwater was attributed to the juniper cuttings. At each site, extension of flows in both time and distance downstream occurred, and riparian vegetation also developed. Along one of these once intermittent drainages (Skull Hollow, Crooked River National Grassland, Oregon), perennial flow was present throughout a mile-long study area and for 0.3 miles downstream four years after treatment.

#### Livestock Grazing

Six years after fencing 7 miles of Willow Creek in the Crooked River National Grasslands in Oregon, flows changed from intermittent to perennial.<sup>4</sup> While Willow Creek for 5 miles above and below the enclosure remained dry in the summer, there was perennial flow within the enclosure. Riparian vegetation recovered, but beaver had not constructed dams within the enclosure. Fencing of McMeen Springs and the creek below (a tributary to Willow Creek) also resulted in development of perennial flow.<sup>4</sup> A similar finding was reported on Camp Creek in Crook County, Oregon.<sup>4</sup> By 1974, 4 miles of Camp Creek had been fenced from cattle. As a result, dramatic increases in wildlife utilization, pronounced buildups of soil within the stream channel, and substantial increases in the amount of riparian vegetation occurred (Winegar 1977). During the droughts of 1977 and 1981, the West Fork of Camp Creek, which is the main source of flow in Camp Creek, became dry. Downstream, however, just within the enclosure, flow began and persisted for four miles and then disappeared just outside the enclosure. Camp Creek now supports fish and beaver, although none were present at the time of fencing.<sup>4</sup>

Change from intermittent to perennial flow on three small, spring-fed Texas streams was observed after elimination of cattle grazing.<sup>5</sup> Big game species were not removed. Riparian vegetation grew

abundant at about the same general time that perennial flow developed. It is unknown if flow from springs increased.

#### DISCUSSION

The research studies that were located generally pre-date the development of modern concepts of streamflow generation from headwater catchments. Specifically, the principles of the variable source area concept (Sattlerlund 1972) have not been used to help interpret riparian water yield improvement research, although this research has almost exclusively been performed in headwater catchments.

Summer flow increases after small dam construction indicates that the potential for water storage and enhanced summer streamflow within small valleys is often unrealized. Enough water can be stored, as a result of a high density of dams, to provide enough water for increases in consumptive water use by riparian plants and for change from intermittent to perennial flow (Heede 1977, Jester and McKirdy 1966, Anon. 1979). By providing materials for debris jams, dams, and instream obstructions, woody riparian species may partly mitigate for water losses through high rates of transpiration during the growing season. Beaver often construct and maintain dams in areas where there would otherwise be few dams, because of the lack of woody debris of sufficient size and abundance to form instream obstructions. Wood brought to the stream by beaver may also later become part of instream obstructions.

Management geared to increase the number of dams on small, low flow streams may have good potential for summer flow augmentation, even in relatively humid areas as demonstrated by findings in Massachusetts (Wilén et al 1975). Small dams often have beneficial effects on fish and waterfowl and can improve watershed values by stabilizing stream channels and trapping sediment. As an alternative to removing woody riparian vegetation to improve water yield during the growing season, the placement of small dams in the channel is especially attractive from a fish and wildlife habitat maintenance standpoint.

The means by which small dams can increase summer streamflow may be postulated. Small dams may increase the size of the zone saturation, or the saturated wedge, contained within the valley bottom. The most striking change in streamflow reviewed, in which check dams installed in gullies of the Alkali Creek drainage resulted in changes from ephemeral flow to perennial flow (Heede 1977), may have been the result of creating a saturated zone within the sediment trapped behind check dams (Heede and DeBano 1984). Small dams may be especially effective in increasing summer flow in stream channels in which channel downcutting has occurred and resulted in a greatly reduced saturated wedge. Peterson (1950) reported that

<sup>4</sup>Winegar, Harold H. 1982. Personal communication. Oregon Department of Fish and Wildlife (retired), Prineville, Oregon.

<sup>5</sup>McCullum, James M. 1982. Personal communication. U.S. Fish and Wildlife Service, Ecological Service Branch, Fort Worth, Texas.

gully on San Simon Creek, Arizona, was accompanied by change to ephemeral flow, and channel aggradation has occurred on several streams where summer streamflow increases have been reported (Winegar 1977, Anon. 1979). The possibility that channel downcutting itself may favor loss of summer flow, without change in climate, should be seriously considered.

The removal of nonriparian vegetation, such as chaparral or conifer, from streambanks and valley slopes near the riparian zone has resulted in increases in summer streamflow (Ingebo 1971, Rich and Thompson 1974, Rowe 1963). In several cases, removal of juniper has apparently resulted in the release of enough water to provide water for developing riparian vegetation and change from ephemeral to perennial flow<sup>4</sup>. These findings demonstrate that in some cases the presence of riparian vegetation is not the most important factor governing summer streamflow, and that nonriparian vegetation removal and conversion to grass may be a management alternative to riparian removal for summer streamflow augmentation in small streams. Advantages to this approach include increase in forage production through control of vegetation not likely to resprout. Disadvantages could include potential destabilization of valley slopes and in many cases the need to remove livestock for a short time after treatment.

It is hypothesized here that the downslope movement of water, or subsurface flow, can be intercepted and transpired by vegetation on valley slopes to a greater degree than presently believed, and that removal of deep-rooted valley slope vegetation can reduce transmission losses as water moves toward the saturated zone in valley bottoms. Diurnal fluctuations in downslope subsurface flow have been measured and are shown to correspond to diurnal fluctuations in streamflow (Burt 1979). During the day, movement of water was toward slope surfaces, and at night downslope movement of water towards the valley bottom resumed. Biswell and Shultz (1958) reported that removal of deep-rooted vegetation upslope from springs resulted in immediate increases in spring flow. Although diurnal fluctuation in streamflow and water tables is often attributed solely to riparian evapotranspiration, vegetation on valley slopes may also play a role. Lewis (1961) reports that diurnal fluctuations in streamflow have been detected before the riparian growing season, and suggested evaporation from riparian zones may play a more important role in controlling streamflow than previously supposed. Diurnal fluctuations in the zone of saturation in response to diurnal fluctuations in subsurface flow could also explain this phenomenon, since valley slope vegetation can begin transpiring earlier in the year than woody riparian vegetation.

Studies involving removal of woody riparian vegetation have shown that summer streamflow can be increased as a result of removal of this vegetation alone, but that savings have been at most moderate. The best water savings after eradication of woody riparian vegetation yet

achieved (Bowie and Kam 1968) amounted to 1.7 acre-feet of water saved per acre of the floodplain treated. This savings, however, represented less than half the total evapotranspirative water losses measured before treatment. After treatment, evaporation and transpiration by untreated vegetation amounted to over 50 percent of the total losses of water found prior to treatment. Substantial increases in evaporation loss were postulated (Bowie and Kam 1968).

Besides shading and maintenance of a moist microclimate, riparian vegetation provides structural materials for beaver dams and debris jams, and also the most important foods for beaver. Other suggested water-conserving functions of true riparian vegetation include building organic soils better able to retain soil moisture (Marcuson 1977), and stabilizing stream channels and prevention of channel degradation and loss of the water table. During overbank flows, riparian vegetation helps slow and spread flows and may encourage better streambottom aquifer recharge. Although removal of riparian vegetation may result in small increases in summer streamflow over the short term, the elimination of woody riparian vegetation and debris over the long term may result in eventual loss of summer streamflow, especially along stream reaches susceptible to gullying.

Livestock are seldom removed from large, intermittent stream sections where unexpected flow increases would be likely to be noticed visually. This may explain why more reports of streamflow increase after removal of livestock are not available. Mechanisms by which summer flow increase might result upon removal of livestock may be hypothesized. Combined utilization of riparian vegetation by beaver and livestock can lead to the virtual elimination of wood, beaver and their dams. Upon removal of livestock, beaver and woody riparian vegetation often reestablish. In gully situations, recovery of riparian vegetation may lead to channel aggradation, improved channel morphology, and improved storage capacity. Beaver may in turn help the situation by colonizing when more water and structural material becomes available. Removal of livestock may result in increased ground cover and reduced compaction in areas contributing to streamflow, resulting in increased infiltration and water storage. As the results from Willow Creek indicate, there may be unknown flow maintenance functions of the riparian zone which may come into play when livestock are removed.

Summer streamflow can be influenced by a large number of interacting factors within the areas contributing to streamflow in small valleys. Information reviewed suggests that riparian vegetation may not be as detrimental to summer streamflow maintenance as is generally supposed, and that there may well be, depending on the situation, management alternatives that would allow for both increasing summer flows and for maintaining or improving riparian zones and other values.

Without including ephemeral channels, small streams (orders 1-4) comprise over 85 percent of the stream mileage on a worldwide average (Windell 1980). Information reviewed, however, suggests

that the complexities of streamflow generation and maintenance in these streams during the dry season are not fully understood. Particularly where dry-season water is at a premium, improved knowledge of summer streamflow generation could be beneficial in many ways.

#### LITERATURE CITED

- Anonymous. 1979. Proceedings of fish habitat improvement workshop. Ochoco Ranger Station, Sept. 26-29, 1978. Oregon Dept. Fish and Wildl. 19pp.
- Bates, J. W. 1963. The effects of beaver on streamflow. Job Comp. Rpt. Fed. Aid Proj. W-65-R, Job C-3g, Utah Dept. Fish and Game. 81pp.
- Biswell, H. N., and A. M. Shultz. 1958. Effects of vegetation removal on spring flow. Calif. Dept. Fish and Game 44(3):211-230.
- Bowie, J. E. and W. Kam. 1968. Use of water by riparian vegetation, Cottonwood Wash, Arizona. U.S. Geol. Surv. Pap. 1858. 62pp.
- Brown, J. B. 1963. The role of geology in a unified conservation program, Flat Top Ranch, Basque County, Texas. Baylor Geol. Stud. Bull. 5, Baylor Univ., Waco, Texas. 29pp.
- Burt, T. P. 1979. Diurnal variations in stream discharge and through flow during a period of low flow. J. Hydrol. 41:291-301.
- Call, M. W. 1970. Beaver pond ecology and beaver trout relationships in south-central Wyoming. Ph.D. thesis, Univ. Wyoming, Laramie. 319pp.
- Dalke, P. D. 1947. The beaver in Missouri. Mo. Conserv. 8(6):1-3.
- Dunford, Earl G., and P. W. Fletcher. 1947. Effect of removal of stream-bank vegetation upon water yield. Trans. Am. Geo. Union 28(1):105-110.
- Finley, W. L. 1937. The beaver - conservator of soil and water. Trans. Am. Wildl. Conf. 2:295-297.
- Graf, William L. 1980. Riparian Management: a flood control perspective. J. Soil Water Cons. Volume 35(4):158-161.
- Heede, B. H. 1977. Case study of watershed rehabilitation project; Alkali Creek, Colorado. USDA For. Serv. Res. Pap. RM-189, Rocky Mtn. For. and Range Exp. Sta., Fort Collins, Colo. 18pp.
- Heede, B. H., and L. F. DeBano. 1984. Gully rehabilitation - a three-stage process in a sodic soil. Soil Sci. Soc. Am. J. 48:1416-1422.
- Horton, J. S., and C. J. Campbell. 1974. Management of phreatophyte and riparian vegetation for maximum multiple use values. Res. Paper RM-117, U.S. Forest Serv., Fort Collins, Colo. 23pp.
- Ingebo, P. A. 1971. Suppression of channel-side chapparal cover increases streamflow. J. Soil and Water Cons. 26:79-81.
- Jester, D. B., and J. H. McKirdy. 1966. Evaluation of trout stream improvement in New Mexico. Ann. Conf. West. Assoc. State Game and Fish Comm. 26:79-81.
- Lewis, D. D. 1961. Effects of controlling riparian vegetation. Arizona Watershed Symp. Proc. 5:27-32.
- Marcuson, P. E. 1977. The effect of cattle grazing on brown trout in Rock Creek, Montana. Mont. Dept. of Fish and Game, Spec. Rpt. Proj. No. F-20-R-21, II-a. 26pp.
- Nanni, U. W. 1972. Water-use by riparian vegetation at Cathedral Peak. S. Afr. For. J. 80:1-10.
- Peterson, H. V. 1950. The problem of gullying in western valleys. In: Applied Sedimentation, John Wiley and Sons, New York pp. 407-434.
- Reid, K. A. 1951. Planning for wildlife on a managed forest. J. Am. For. 49(6):436-439.
- Rich, L. R., and J. R. Thompson. 1974. Watershed management in Arizona's mixed conifer forests: the status of our knowledge. USDA For. Serv. Res. Pap. RM-130, Rocky Mtn. For. and Range Exp. Stat., Fort Collins, Colo. 15pp.
- Rowe, P. B. 1963. Streamflow increases after removing riparian vegetation from a southern California watershed. J. Forestry 61:365-370.
- Satterlund, Donald, R. 1972. Wildland Watershed Management. The Ronald Press Co., New York.
- Smith, L. H. 1938. Beaver and its possibilities in water regulation. Univ. Idaho Bull. 33(22):85-88.
- Sopper, William E. 1971. Water supply augmentation by watershed management in wildland areas. Nat. Water Comm. Rpt. NWL 71-008: 65-90.
- Strahler, A. N. 1957. Quantitative analysis of watershed geomorphology. Trans. Am. Geophys. Union 38:913-920.
- Tappe, D. T. 1942. The status of beavers in California. Calif. Dept. Nat. Res., Game Bull. No. 3. 59pp.
- Wilens, B. O., Bill P. MacConnell, and Donald L. Mader. 1975. The effects of beaver activity on water quality and water quantity. Proc. Soc. Am. For.:235-240.
- Windell, John T. 1980. Colorado Water Resource-- Status 1980. Proc. Colo.-Wyo. Chap. Am. Fish Soc. 15:47-57.
- Winegar, Harold H. 1977. Camp Creek channel fencing - plant, wildlife, and soil, and water response. Rangeman's Jour. 4(2):10-12.

# The Effects of Streamflow Modification on the Development of a Riparian Ecosystem<sup>1</sup>

Robert C. Szaro and Leonard F. DeBano<sup>2</sup>

---

Abstract.--The interrelationships between riparian vegetation development and hydrologic regimes in a ephemeral desert stream were examined at Whitlow Ranch Dam along Queen Creek in Pinal County, Arizona. Our data indicates that a flood control structure can have a positive impact on riparian ecosystem development and could be used as a mitigation tool to restore this critically threatened habitat.

---

## INTRODUCTION

Less than 25 years ago the focus on riparian vegetation was from the perspective of controlling phreatophytes to increase water yield (Campbell 1970, Horton 1972). Since that time the focus has shifted in the other direction to the importance, preservation, and restoration of riparian habitat (Johnson and Jones 1977). Road construction, dams, grazing, agricultural encroachment, and recreational uses have all been blamed for the continued loss of riparian habitat. Techniques for replacing this lost habitat include revegetation (Anderson and Ohmart 1979) and utilizing the increased water yield resulting from shrub control to increase flow in ephemeral channels (DeBano et al. 1984).

There has been little work on how changes in the hydrologic regime and river bed morphology resulting from dam construction may affect riparian vegetation. Previous work has emphasized how stabilized water flows reduce regeneration of flood-adapted species (Brown et al. 1977, Fenner et al. 1985). However, we will examine a case where dam construction increased riparian vegetation. The importance of increased sediment deposition and near perennial stream flow on riparian vegetation development will also be discussed.

## SITE DESCRIPTION

The study area is along Queen Creek on the Tonto National Forest, about 16 km west of Superior, Pinal County, Arizona (figs. 1, 2, 3). The site is at an elevation of 625 m. In November 1960, the U.S. Army Corps of Engineers completed Whitlow Ranch Dam on the site as a flood control improvement for the community of Queen Valley. The dam is an earthfill structure with a maximum height of 45 m and a crest length of 255 m. The reservoir behind the structure was designed to store 44 million cubic meters ( $M m^3$ ) of water with a peak inflow of 3,100 cubic meters per second ( $m^3/s$ ) before flowing through the emergency spillway. The dam is equipped with a large draw-down tube that drains the impoundment (at a maximum rate of 28.3  $m^3/s$  during stormflows) into a canal for downstream use. The dam was provided with a large emergency spillway, but no water has been discharged over it since construction.

## METHODS

### Vegetation Analysis

The study area was subdivided into six distinct vegetative units based on visual examination: riparian interior, riparian edge, stream bed, stream bank, desert wash, and desert upland. Ten 15 m-radius (0.7 ha) macroplots were selected in each unit. The initial plot in each vegetative subdivision was randomly selected. The riparian interior and edge plots were located in the riparian stand immediately behind the dam. The stream bed and stream bank plots were located 1 km upstream of the upper portion of the riparian stand to insure sampling beyond the water influence zone of the structure. The desert wash and desert upland plots were located at 100 m intervals on 1 km transects perpendicular to the edge of the riparian stand.

Within each macroplot all trees greater than 2.5 cm dbh were measured and tree species

---

<sup>1</sup> Paper presented at the Symposium, Riparian Ecosystems and Their Management: Reconciling Conflicting Uses. [Tucson, Arizona, April 16-18, 1985],<sup>2</sup>

<sup>2</sup> Robert C. Szaro is a Research Wildlife Biologist and Leonard F. DeBano is a Principal Soil Scientist, USDA Forest Service, Rocky Mountain Forest and Range Experiment Station, Arizona State University Campus, Tempe, Arizona 85287.

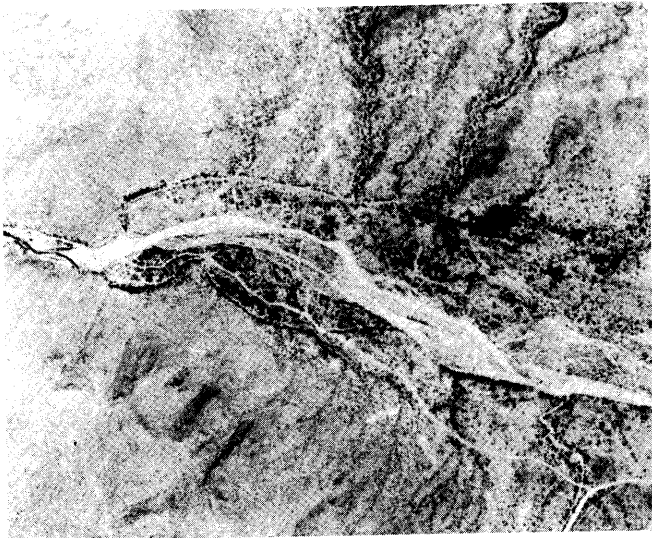

Figure 1.--Aerial photo taken 7 June 1958 of the Whitlow Ranch Dam site prior to construction. Upstream is to the right in the photo.

recorded. All shrubs and subshrubs including saplings and seedlings were counted, and the diameters of the first 20 shrubs of each species in each plot were measured. Shrub cover for each plot was then calculated using a mean shrub size for that plot or actual shrub size for those shrubs with less than 20 individuals. Eight 20-by 50-cm microplots were sampled in each plot. Crown cover of each herbaceous species was recorded as a percentage of the microplot area.

Estimates of riparian interior and edge area were made using a digitizer and aerial photos.

#### Hydrologic Analysis

Daily and instantaneous streamflow records have been maintained at Whitlow Dam since its construction in 1960 (there are some gaps in the records because of instrument failure). Data collected included instantaneous inflow ( $m^3/s$ ), outflow ( $m^3/s$ ), and storage ( $m^3$ ).

The streamflow and storage data from 1963 to 1983 were summarized to determine the effect of Whitlow Dam on the hydrologic regime of the stream reach on Queen Creek now occupied by the impoundment. Inflow and outflow data were classified into storm and non-storm periods. Because Queen Creek is an ephemeral stream, it was assumed inflow occurred only during storm periods and that outflow occurred both during storm and non-storm periods. During storms, outflow was through the draw-down tube which drained any free standing ponded water. If a structure had not been present these stormflows would have moved rapidly downstream. Outflow during non-storm periods was produced by the slow drainage of saturated sediments and banks above the dam. Based on these assumptions records of

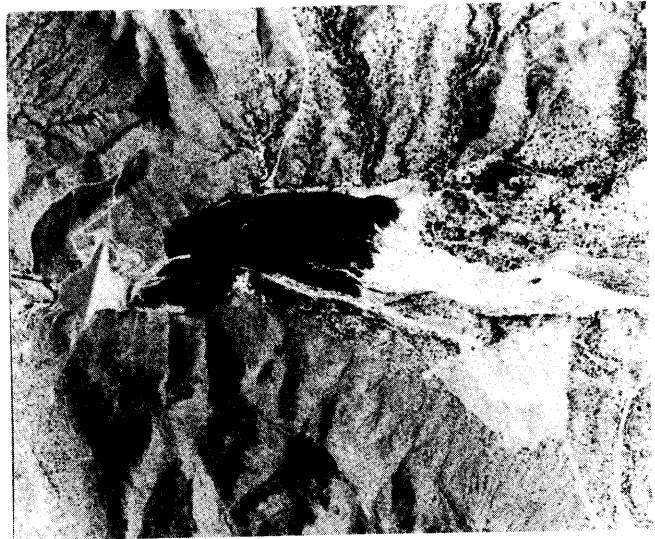

Figure 2.--Aerial photo of Whitlow Ranch Dam taken 16 June 1967. Note the lack of vegetation along the top border of riparian vegetation behind the dam.

daily and instantaneous inflows were used to reconstruct the flow regime that would have existed had the reservoir not been constructed. The data for storm and non-storm periods were expressed in terms of the number of days each type of flow occurred per hydrologic year (October 1 to September 30) from 1960 to 1983. Outflow from the structure represents the streamflow regime that existed after the structure had been constructed.

The maximum instantaneous and daily amounts of water stored above the structure were also

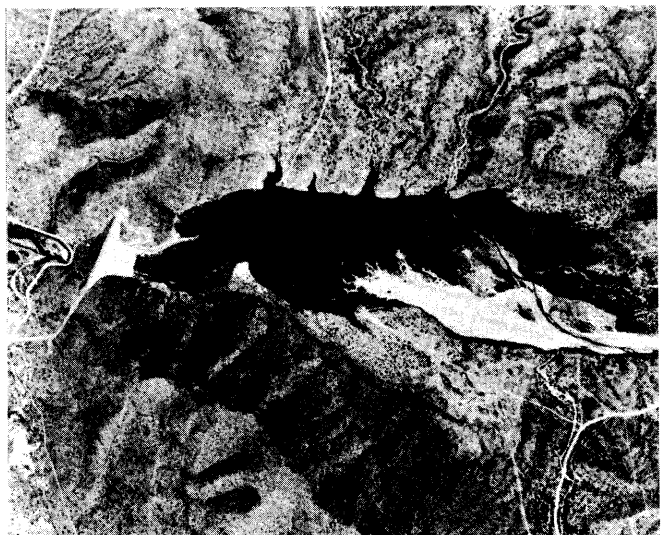

Figure 3.--Aerial photo of Whitlow Ranch Dam taken 7 April 1980. Note the substantial invasion of vegetation up the adjacent desert washes.



Table 1.--Tree densities (trees/hectare), total basal area (T.B.A.) of trees (m<sup>2</sup>/hectare), shrub densities (shrubs/hectare) and shrub cover (m<sup>2</sup>/hectare).

SPECIES	Riparian Interior		Riparian Edge		Stream Bed		Stream Bank		Desert Wash		Desert Upland	
	Density	T.B.A.	Density	T.B.A.	Density	T.B.A.	Density	T.B.A.	Density	T.B.A.	Density	T.B.A.
<u>Trees</u>												
<u>Acacia greggii</u>									8± 5	t	1± 1	t
<u>Cereus giganteus</u>									20± 9	3± 1	34± 13	5± 2
<u>Cercidium microphyllum</u>									64± 15	1± 0	66± 14	1± 0
<u>Lycium spp.</u>									1± 1	t		
<u>Nicotiana glauca</u>			1± 1	t								
<u>Olneya tesota</u>								3± 3	t	1± 1	t	1± 1
<u>Opuntia bigelovii</u>											4± 2	t
<u>Opuntia fulgida</u>											3± 2	t
<u>Populus fremontii</u>	1± 1 <sup>a</sup>	t <sup>b</sup>	1± 1	t								
<u>Prosopis velutina</u>			35± 19	t			11± 5	t	69± 17	3± 1		
<u>Salix gooddingii</u>	236± 34	23± 3	41± 13	6± 2					1± 1	t		
<u>Tamarix pentandra</u>	788± 139	7± 1	833± 134	9± 1								
<b>Tree Totals</b>	<b>1025± 128</b>	<b>29± 2</b>	<b>911± 130</b>	<b>15± 2</b>	<b>0</b>	<b>0</b>	<b>14± 6</b>	<b>t</b>	<b>164± 22</b>	<b>7± 1</b>	<b>109± 21</b>	<b>6± 2</b>
<u>Shrubs</u>												
<u>Acacia greggii</u>							23± 10	26± 19	184± 27	523± 97	18± 17	12± 12
<u>Ambrosia deltoidea</u>									266± 158	79± 39	4101± 486	897± 125
<u>Ambrosia ambrosioides</u>					11± 5	15± 9	6± 4	2± 2	35± 24	8± 5		
<u>Baccharis glutinosa</u>	41± 36	85± 69	439± 114	2418± 624	9± 4	5± 4	413± 60	1697± 185	127± 122	302± 288		
<u>Baccharis sarathroides</u>									17± 9	4± 1		
<u>Calliandra eriophylla</u>									4± 3	t		
<u>Celtis pallida</u>			1± 1	t			14± 6	49± 28	51± 16	286± 99	6± 4	t
<u>Cercidium microphyllum</u>					3± 3	t			71± 28	109± 46	42± 16	53± 18
<u>Cereus giganteus</u>									1± 1	t	9± 3	t
<u>Condalia lycioides</u>									30± 11	37± 13	6± 2	4± 2
<u>Echinocereus spp.</u>									3± 2	t	255± 68	13± 3
<u>Encelia farinosa</u>									1± 1	t	16± 12	1± 1
<u>Ephedra spp.</u>									23± 13	12± 7	17± 17	4± 2
<u>Ericameria laricifolia</u>					3± 3	t	3± 3	2± 2	3± 3	t	6± 6	t
<u>Eriogonum fasciculatum</u>					3± 3	2± 1			106± 50	23± 10	1787± 464	163± 49
<u>Ferocactus wislizenii</u>									6± 4	t	9± 3	1± 1
<u>Fouquieria splendens</u>									3± 3	2± 2	13± 6	14± 8
<u>Krameria parvifolia</u>									96± 43	70± 31	136± 33	56± 18
<u>Larrea tridentata</u>									267± 102	523± 217	151± 76	326± 178
<u>Lycium spp.</u>							9± 6	15± 9	57± 14	90± 25	26± 10	10± 5
<u>Mammillaria microcarpa</u>									3± 3	t	96± 48	t
<u>Nicotiana glauca</u>	35± 16	27± 13	42± 28	33± 22	3± 3	t			14± 8	4± 3	134± 30	30± 6
<u>Opuntia bigelovii</u>									7± 3	2± 1	126± 27	48± 23
<u>Opuntia fulgida</u>									23± 12	5± 2	61± 20	15± 6
<u>Opuntia leptocaulis</u>					3± 3	t			11± 6	6± 3	89± 27	43± 15
<u>Opuntia phaeacantha</u>									3± 3	t	37± 16	14± 8
<u>Opuntia versicolor</u>									1± 1	t		
<u>Populus fremontii</u>			30± 21	93± 66			3± 3	10± 10	17± 6	52± 16		
<u>Prosopis velutina</u>					3± 3	t						
<u>Ricinus communis</u>	3± 3	t										
<u>Simmondsia chinensis</u>									14± 11	10± 9	142± 31	50± 13
<u>Tamarix pentandra</u>	200± 41	39± 8	709± 256	139± 50					103± 103	5± 5		
<u>Hymenoclea monogyra</u>					942± 262	1091± 204	806± 264	856± 319	8± 8	63± 63		
<u>Olneya tesota</u>							3± 3	1± 1				
<b>Shrub Totals</b>	<b>279± 54</b>	<b>152± 69</b>	<b>1221± 232</b>	<b>2683± 570</b>	<b>979± 256</b>	<b>1171± 195</b>	<b>1280± 245</b>	<b>2661± 186</b>	<b>1555± 354</b>	<b>2211± 267</b>	<b>7283± 770</b>	<b>1754± 133</b>

<sup>a</sup> Mean ± Standard Error, N = 10.

<sup>b</sup> t = trace amount, less than 1 m<sup>2</sup>.

summarized for the period of record to estimate the quantities of water stored.

## RESULTS

### Vegetation Response

Prior to the construction of Whitlow Ranch Dam, Sonoran riparian scrubland extended many kilometers upstream from the dam site (fig. 1). There were no trees in the stream bed, but high densities of burrobrush (Hymenoclea monogyra) (table 1). In contrast, the stream bank had 11 velvet mesquite (Prosopis velutina) and 3 ironwood (Olneya tesota) trees per hectare. Moreover, desert broom (Baccharis sarathroides) was a co-dominant shrub along with the burrobrush.

Only 7 years after completion, aerial photos documented a dramatic change in the vegetation behind the dam (fig. 2). The riparian vegetation consisted of a vigorously expanding Sonoran deciduous forest of Goodding willow (Salix gooddingii) and saltcedar (Tamarix pentandra) occupying an area of approximately 17.7 ha. By April 1980 the riparian stand behind the dam had expanded to 29 ha (fig. 3). The riparian interior was characterized by large willow trees, large numbers of smaller saltcedars, few shrubs, and low herbaceous cover (tables 1 and 2). In contrast, the riparian edge had significantly fewer willows (p<0.05, t-test) and as many saltcedars as the riparian interior. However, the riparian edge also had three times the number of mesquite trees than found on the stream bank. It also had high densities of seepwillow (Baccharis glutinosa) instead of desert broom and

burrobrush. In 1980, there were 18.8 ha of riparian interior and 10.2 ha of riparian edge.

Water-influenced vegetation has also developed in desert washes tributary to the reservoir. From 1967 to 1980 there was a pronounced increase in vegetation density in the desert wash. The wash vegetation is a mixture of desert upland, stream bank, and riparian edge species including saltcedar, seepwillow, velvet mesquite, desert hackberry (Celtis pallida) and creosotebush (Larrea tridentata) (table 1). However, herbaceous cover of 23.3% was significantly higher than on any other area ( $p < 0.05$ , Duncan's multiple range test) (table 2). The desert upland, unlike the desert wash, lacked the water-influenced vegetation and had high densities and cover values of bursage (Ambrosia deltoidea) and buckwheat (Eriogonum fasciculatum).

#### Hydrologic Response

Analysis of the inflow records showed that if the reservoir had not been present, the channel reach would only have been wetted by stormflow on the average of 24 days per year ( $s = \pm 26.1$ ) between 1960 and 1983 (fig. 4). The number of days stormflow occurred varied from 1 day in hydrologic year 1981 to 109 days in 1979. A parallel analysis of the outflow records showed that flow was nearly-perennial after construction of the dam although the outflow rates sometime

dropped to as low as .03 m<sup>3</sup>/s. The number of days non-storm outflow occurred averaged 341 ( $s = \pm 25$ ) per year and ranged from 256 in 1979 to 364 in 1980.

High intensity storms produced high peaks and provided most of the inflow into the impoundment. Instantaneous and daily peak inflows during these storm periods showed streamflow ranged widely. The largest instantaneous and daily peak inflows were 310 and 79 m<sup>3</sup>/s, respectively, during a storm period on October 19, 1972. These flows were ponded temporarily behind the structure so that the maximum instantaneous and daily outflows through the draw-down tube were 19.1 and 18.9 m<sup>3</sup>/s, respectively. During this storm, the maximum instantaneous and daily storage levels in the impoundment were 5.9 and 5.4 M m<sup>3</sup>. The impounded water was stored in the reservoir for several days before it was emptied by the draw-down tube. During this storm more than 0.31 M m<sup>3</sup> of water was stored in the reservoir for 5 days.

Another large storm occurred during the end of February and beginning of March 1978. Although the instantaneous and daily peak flows were only 49.7 and 38.9 m<sup>3</sup>/s, respectively, about 7.1 M m<sup>3</sup> of water was stored instantaneously in the reservoir. The maximum daily storage was 6.6 M m<sup>3</sup> on March 6, 1978. Over 0.5 M m<sup>3</sup> of water was stored in the reservoir from February 28 to March 9. Although the impoundment was only partially filled, the reservoir, water would have infiltrated into the sediment and banks immediately upstream from the structure. During non-storm periods this water was used by plants or drained slowly from the banks and sediment to produce near-perennial flow from the reservoir.

Table 2. Percent herbaceous cover.

SPECIES	Riparian		Stream		Desert	
	Interior	Edge	Bed	Bank	Wash	Upland
<u>Amaranthus</u> spp.		t				
<u>Andropogon</u> spp.					t	
<u>Baileya multiradiata</u>					t	
<u>Bromus rubens</u>					16±3	6±2
<u>Cynodon dactylon</u>			4±3	8±4		
<u>Datura meteloides</u>			t			
<u>Eriogonum defexum</u>					t	t
<u>Eriogonum inflatum</u>					t	1±0
<u>Helianthus ciliaris</u>		t				
<u>Kerniaria cinerea</u>					t	
<u>Marrubium vulgare</u>				t		
<u>Mentzelia pumila</u>			t	t		
<u>Mimulus guttatus</u>	t <sup>a</sup>	1±1				
<u>Plantago</u> spp.					3±1	4±1
<u>Poa</u> spp.					2±1	t
<u>Polanisia trachysperma</u>				t		
<u>Polygomon monspeliensis</u>	3±1 <sup>b</sup>	1±0				
<u>Rumex hymenosepalus</u>	1±1	1±1	t			
<u>Trixis californica</u>					1±1	
<u>Veronica americana</u>	t					
<u>Viguiera annua</u>		1±1				
<u>Xanthium saccharatum</u>	1±1	t				
Total	5±1	4±1	5±3	8±4	23±4	11±3

<sup>a</sup> Mean ± standard error, N = 80.

<sup>b</sup> t = trace amount, less than 1 percent.

Sediment accumulated in the impoundment over the years. By 1975 about 8.6 M m<sup>3</sup> of sediment was measured. Although the exact amount is not known, the present sediment is level with the top of the draw-down structure. Samples of the upper layers of sediment deposited in the reservoir showed it to contain between 17 and 40% clay, 28 and 39% silt, and 22 and 55% sand.

#### DISCUSSION

Since Whitlow Ranch Dam does not act like the typical storage dams found on other Arizona drainages, its impact on the land area behind the structure has been considerably different. There is a continual release of water after each storm event which results in water storage for only limited time periods. Thereby, in addition to species such as saltcedar, which is known to readily establish around reservoirs (Warren and Turner 1975), a large stand of flood-adapted Goodding willow has developed above the dam. In contrast to storage structures that negatively modify downstream conditions by stabilizing water flows, reducing floodplain inundation, and decreasing alluvial seedbeds (Brown et al. 1977, Fenner 1985), Whitlow Ranch Dam has just the opposite effect on upstream conditions. It enhances even moderate flows, causing gradually

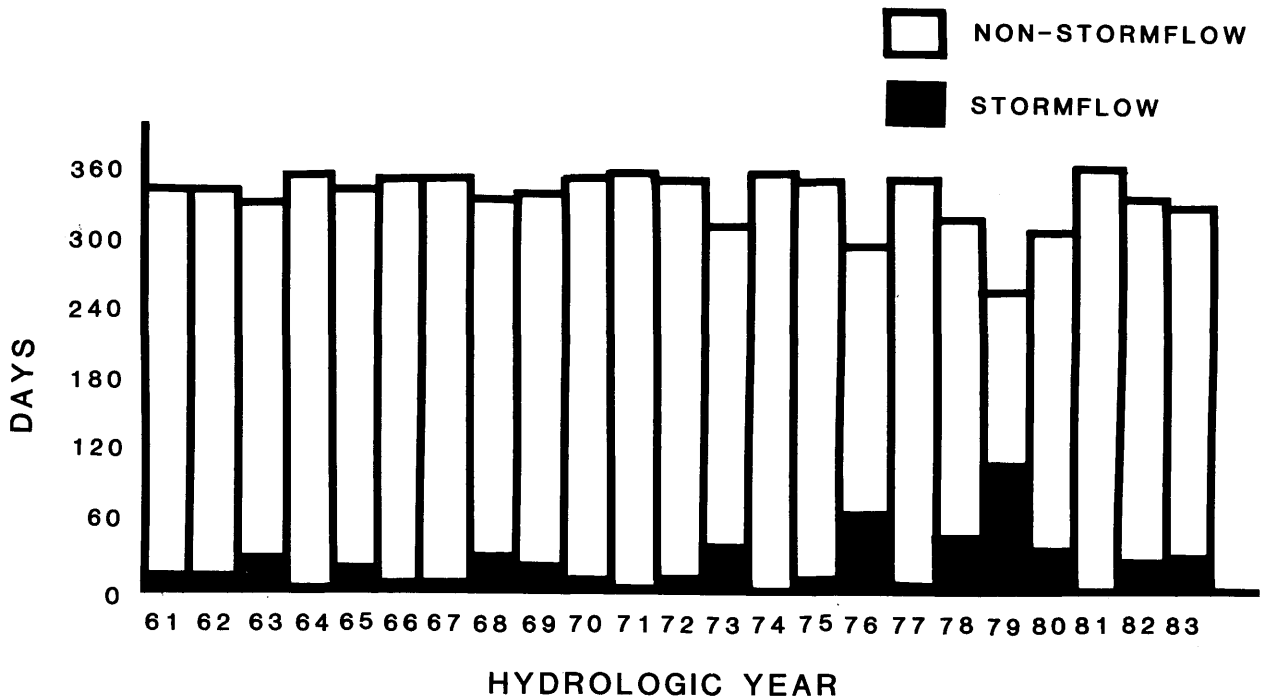

Figure 4.--The number of days per year of storm and non-storm flows through Whitlow Ranch Dam, 1961-1983.

receding water levels, establishment of alluvial seedbeds through sediment deposition, and the maintenance of low flow conditions for most of the year. Anderson and Ohmart (1979) reported that the cost of replacing riparian vegetation is about \$10,000 per hectare. Thus, Whitlow Ranch Dam has resulted in the replacement of almost \$300,000 of riparian habitat although it was not designed for that purpose.

In conclusion, our data indicates that a flood control structure can have a positive impact on riparian ecosystem development, and could be used as a mitigation tool to restore this critically threatened habitat in an arid environment.

#### LITERATURE CITED

- Anderson, Bertin W., and Robert D. Ohmart. 1979. Riparian revegetation: An approach to mitigating for a disappearing habitat in the Southwest. p. 481-487. In The mitigation symposium: A national workshop on mitigating losses of fish and wildlife habitats. [Fort Collins, Colo., July 16-20, 1979] USDA Forest Service General Technical Report RM-65, 696 p. Rocky Mountain Forest and Range Experiment Station, Fort Collins, Colo.
- Brown, David E., Charles H. Lowe, and Janet F. Hausler. 1977. Southwestern riparian communities: Their biotic importance and management in Arizona. p. 201-211. In Importance, preservation, and management of riparian habitat: A symposium. [Tucson, Ariz., July 9, 1977] USDA Forest Service General Technical Report RM-43, 217 p. Rocky Mountain Forest and Range Experiment Station, Fort Collins, Colo.
- Campbell, C. J. 1970. Ecological implications of riparian vegetation management. *Journal of Soil and Water Conservation* 25:49-52.
- DeBano, L. F., J. J. Brejda, and J. H. Brock. 1984. Enhancement of riparian vegetation following shrub control in Arizona chaparral. *Journal of Soil and Water Conservation* 39(5):317-320.
- Fenner, Pattie, Ward W. Brady, and David R. Patton. 1985. Effects of regulated water flows on regeneration of Fremont cottonwood. *Journal of Range Management* 38(2):135-138.
- Horton, Jerome S. 1972. Management problems in phreatophyte and riparian zones. *Journal of Soil and Water Conservation* 27:57-61.
- Johnson, R. Roy, and Dale A. Jones, tech. coord. 1977. Importance, preservation, and management of riparian habitat: A symposium. [Tucson, Ariz., July 9, 1977] USDA Forest Service General Technical Report RM-43, 217 p. Rocky Mountain Forest and Range Experiment Station, Fort Collins, Colo.
- Warren, Douglas K., and Raymond M. Turner. 1975. Saltcedar (*Tamarix chinensis*) seed production, seedling establishment, and response to inundation. *Journal of the Arizona Academy of Science* 10:135-144.

# Focused Recreation Use in Riparian Ecosystems: A Taxonomy of User Types<sup>1</sup>

Jean C. Behrens-Tepper, Joseph T. O'Leary, Douglas C. Andersen<sup>2</sup>

---

Abstract.--Using data from the 1980 National Survey of Fishing, Hunting and Wildlife Associated Recreation, this paper examines Indiana anglers by amount of participation at rivers and streams, sociodemographic background and conservation activity involvement. Each of these factors appears to facilitate identification of different user types that should be considered in managing and planning riparian environments.

---

## INTRODUCTION

Riparian ecosystems in Indiana and the mid-west are critical habitats for recreation and wildlife now and in the future. In the most recent Indiana Outdoor Recreation Plan (IDNR 1984), rivers and streams are identified as a major statewide issue and priority in terms of developing opportunities and access, restoring the riparian corridor, and confronting the problem of water quality. Action must consider the types of users of these environments. By identifying subgroups of recreation participants with high commitment to the riparian resource, management agencies may be better able to elicit support and to minimize conflict through interaction with these clients.

Using data from the 1980 National Fishing and Hunting Survey this study examines the degree of focused (specialized) use of riparian ecosystems by persons involved in sport fishing in the state of Indiana. Particular attention is paid to identifying variables that can be used to develop a taxonomy of user types.

## RELATED RESEARCH

Recreation specialization (or what we have called focused use) is a concept that has recently been advanced as a way of disaggregating

participants in recreation activities into more homogeneous subgroups (Bryan 1977, 1979; Romsa and Girling 1976; O'Leary and Pate 1978; Stebbins 1982; Wellman et al. 1982).

Bryan (1977,1979) noted that definite levels of specialization are found within any recreation activity. He noted that a continuum of behaviors can be found that can be differentiated by equipment, skills and setting preferences. Developing the notion of "leisure social worlds", Bryan suggested that the most specialized individuals form a peer group network with fellow specialists. In addition, this group was hypothesized to have the strongest commitments toward conservation and how the process should be directed. Wellman et al. (1982) further developed this notion by suggesting that small groups of highly committed and expert people emerge who tend to set the standards for attitudes and behavior in an activity.

The concept is interesting for riparian management and planning. The classification scheme is straightforward and makes intuitive sense. The notion of people starting some activity at a given level of involvement and progressing to greater levels of commitment and discrimination is familiar, and its application to recreation seems reasonable. The scheme presents those who would use it with an easily understood construct on which people are arrayed from low to high, rather than being classified according to complex, empirically derived scales with nuances in scale labelling and interpretation. The designation of participants types also has substantive support from the recreation behavior literature that has recently argued for a movement away from the more traditional activity vs. activity comparison to a consideration of groups of actors operating along a continuum of involvement (Vaske et al. 1982). Without this understanding of structure and process, inappropriate resolution techniques for conflict and management strategies are likely to be adopted by resource agencies.

---

<sup>1</sup> Paper presented at the Interagency North American Conference on Riparian Ecosystems and Their Management, University of Arizona, Tucson, April 16-18, 1985.

<sup>2</sup> Jean C. Behrens-Tepper, Graduate Research Assistant; Joseph T. O'Leary, Associate Professor of Forest Recreation; and Douglas C. Andersen, Assistant Professor of Wildlife Ecology are all in the Dept. of Forestry & Natural Resources, Purdue University, W. Lafayette, IN 47907.

This research supported through the Purdue University Water Resources Research Center (USGS - Grant Agreement No. 14-08-001-G905).

Recent research has attempted to provide empirical support for Bryan's ideas about activity specialization. Graefe (1980) demonstrated that annual frequency of angling participation was a useful surrogate measure for angling specialization. Katz (1981), testing Bryan's resource setting dependency proposition, found that environmental concerns increased with higher fly fishing participation levels in Pennsylvania anglers. Kauffman (1984) reached similar conclusions from a study of canoeists. The findings of a study by McGurrian (1984) indicated that highly specialized Maryland trout fishermen exhibited greater commitment to the sport, had more specific quality requirements, and had greater interest in conservation of the resource than less specialized anglers.

Sufficient evidence exists to warrant additional investigation of the specialization concept. From this discussion, this paper examines two key questions. First, can we identify variables that are appropriate for classifying different users? Second, can this classification be developed from an extensive set not specifically designed for specialization study?

#### METHODS

The source of data for this study was the 1980 National Survey of Fishing, Hunting, and Wildlife-Associated Recreation, conducted by the U.S. Bureau of Census (USBC), for the U.S. Fish and Wildlife Service (USFWS).

The survey was conducted in two phases. The initial screening phase, conducted primarily by phone, sought to identify households in which at least one member, 6 years or older, engaged in wildlife-associated sport or recreation. The followup phase consisted of detailed, personal interviews with all actual users of the wildlife resource, 16 years and older, in selected households with participants. The followup Hunting and Fishing Questionnaire, File FH-3, yielded over 35,000 records of individual sportsmen nationwide, with 5676 characters of information for each respondent. Of 771 Indiana sportsmen selected for detailed interviewing, roughly 680 interviews were completed.

After selecting the Indiana respondents from the data base, the analysis used only those cases where the respondent had done freshwater fishing in rivers and streams (File FH3, Item I2930B3) in 1980.

The USBC procedure for inflation of the weighted sample results to independent estimates of the entire population was not used.

Computations were performed on the Purdue University CDC 6500 Computer using the SPSS data analysis system. SPSS subprograms for frequencies and crosstabulations were run in order to determine the distribution of days spent fishing and to test the strength of relationships under consideration.

#### RESULTS

A frequency analysis of the responses to questions about type of freshwater used indicated that 44% of the Indiana angler population had fished in rivers or streams in 1980. Further analysis revealed two distinct subgroups: those anglers that did at least some river and stream fishing and those that did most of their fishing in this type of water. These subgroups comprised 29% and 15% of the total angler population, respectively.

Crosstabulation of the sociodemographic variables of those individuals who had or had not engaged in river and stream fishing indicated statistically significant gender and age differences between the two groups. The results of the age analysis are the more interesting (Table 1) because they appear to conflict with Bryan's proposition of advanced years being related to increased specialization level and resource setting preference.

Table 1.--Age of respondent by participation in river and stream fishing. (Associations were statistically significant at  $\alpha = 0.01$ )

Age	River & Stream Fishing	
	No	Yes
16-25 years	54%	46%
26-35	52	48
36-45	50	51
46-55	62	38
56-65	71	29
GTE 66	76	24
% Total Population	56	44

Continuing the analysis of factors affecting resource setting preference, the annual frequency of participation (high, medium, or low classification of days afield) was found to be significantly related to riparian resource dependency (level of river and stream concentration) (Table 2). Bryan's contention that increased angler specialization implies a shift from consumption to preservation was supported by 2 of 4 measures used. A significantly higher percentage of those Indiana anglers who do fish in rivers and streams read outdoor magazines, and read these magazines more frequently than those who do not use this resource setting. However, there was no

Table 2.--Frequency of angling participation by level of river and stream concentration. (Associations were statistically significant at  $\alpha = 0.01$ )

Frequency of Participation	River & Stream Fishing		
	None	Some	Most
Lo (1-7 days)	69%	18%	13%
Med (8-30)	57	30	14
Hi (GTE 31)	45	36	19
% Total Population	56	29	15

significant difference between these two user groups in percentages of individuals who paid dues to local or national conservation organizations. Interestingly, a significantly higher percentage of river and stream anglers also participated in hunting in 1980. River and stream anglers comprised 50% of those Indiana anglers who hunt and 40% of the 1980 Indiana hunter population.

#### DISCUSSION AND CONCLUSIONS

The results indicate the presence of several different angler subgroups focused on use of the riparian environment in Indiana. We have been able to identify a few variables that will facilitate discrimination of these groups.

The large percentage of anglers reporting river and stream fishing was unanticipated as the State of Indiana has recently acknowledged problems encountered by recreationists seeking access to these areas. We speculate that as these problems are alleviated the percent of anglers using this resource setting would increase. In addition, the intent of urban communities to develop the river corridor as an economic and recreational partnership should also precipitate greater pressure on the riparian ecosystem.

These observations imply a need for flexibility in management strategies for riparian resource allocation in order to accommodate the variability exhibited by resource users. The ability to identify intra-state subgroups of users exhibiting different characteristics also points out the need to more carefully explore the data being provided in large national surveys. It might also be useful to examine the relationship between anglers and the high concentration of these people in the hunting population. To the extent subgroups within the angler population are apparent, does this contribute to identifying subgroups in other activities like hunting?

The human dimensions of fish and wildlife management will increasingly be the foundation upon which planning and policy must be based, no longer on habitat and species questions alone. Unless we incorporate human dimension information as it relates to the riparian environment in our decision-making processes, our solutions will ultimately fail.

#### LITERATURE CITED

- Bryan, H. 1977. Leisure value systems and recreational specialization: the case of trout fishermen. *J. Leisure Res.* 9(3):174-187.
- \_\_\_\_\_. 1979. Conflict in the great outdoors. *Sociological Studies* No. 4, 98 p. Bureau of Pub. Admin., Univ. of Alabama, University, AL.
- Graefe, A.R. 1980. The relationship between level of participation and selected aspects of specialization in recreational fishing. Ph.D. Dissertation, 155 p. Texas A&M Univ., College Station, TX.
- Katz, M. 1981. An assessment of intra-group differences in conservation attitudes and environmentalism as a function of activity involvement among fly fisherman. Ph.D. Dissertation, 277 p. Pennsylvania State Univ., University Park, PA.
- Kauffman, R.B. 1984. The relationship between activity specialization and resource related attitudes and expected rewards for canoeists. Ph.D. Dissertation, 133 p. Univ. of Maryland, College Park, MD.
- McGurrin, J.M. 1984. Angler specialization in Maryland trout fisherman. M.S. Thesis, 60 p. Univ. of Maryland, College Park, MD.
- O'Leary, J.T. and G. Pate. 1978. An examination of frequency of participation in water-based activities by recreation consumers in Indiana. Tech. Rpt. No. 114, 18 p. Water Resources Research Center, Purdue Univ., W. Lafayette, IN.
- Romsa, G. and S. Girling. 1976. The identification of outdoor recreation market segments on the basis of frequency of participation. *J. Leisure Res.* 8(4):247-255.
- State of Indiana, Department of Natural Resources. 1984. Outdoor Recreation Plan, 95 p. Indianapolis, IN.
- Stebbins, R.A. 1982. Serious leisure: a conceptual statement. *Pacific Sociological Review* 25(2):251-272.
- Vaske, J., M.P. Donnelly, T.A. Heberlein, and B. Shelby. 1982. Differences in reported satisfaction ratings by consumptive and on consumptive recreationists. *J. Leisure Res.* 14(3):195-206.
- Wellman, J., J.W. Roggenbuck, and A.C. Smith. 1982. Recreation specialization and norms of depreciative behavior among canoeists. *J. Leisure Res.* 14(4):323-340.

# The Economic Value of Sportfishing at Lees Ferry, Arizona<sup>1</sup>

MERTON T. RICHARDS AND D. BRENT WOOD<sup>2</sup>

---

Economic values were estimated for trophy and non-trophy anglers at Lees Ferry, Arizona. Management recommendations are made, based on these values, that permit discrimination between various users of the riparian environment and among anglers specifically.

---

## INTRODUCTION

The Lees Ferry fishery is a fifteen mile stretch of the Colorado River in northern Arizona. It is within Glen Canyon National Recreation Area and is managed by the National Park Service. Anglers are attracted by the trophy-size trout commonly taken from these cold, clear waters as well as by the red-walled canyon's spectacular scenery. Lees Ferry has gained widespread popularity in recent years leading to dramatic increases in recreational use. Park Service managers have expressed concern that the experience available to visitors may be deteriorating. The Arizona Game and Fish Department, responsible for managing the biological resource, is also concerned that increases in use may inhibit their ability to maintain an adequately-stocked fishery. Current policies of the two agencies responsible for the management of Lees Ferry are not addressing what officials perceive as a worsening situation, and the absence of an adequate data base has hindered their attempts to arrive at appropriate policy decisions.

To manage Lees Ferry for its optimal use, managers need to know the desired experiences that motivate different user groups. They also need to know how the different groups might react to policies designed to control visitor numbers. In addition, it is important to know the values that different groups attach to their desired experiences. An economic measure of the benefits enjoyed by visitors to Lees Ferry resulting from sportfishing opportunities would allow managers

to assess the worth of their management activities. Measures of differences in the benefits derived by different angler groups permit managers to evaluate the relative impacts of policies that discriminate between users.

The objectives of the analysis are:

1. To establish a base of information on visitor characteristics and their perceptions, preferences, and practices.
2. To estimate the economic value of sportfishing experiences.
3. To make recommendations for improving the management of the Lees Ferry fishery based on research findings.

## ECONOMIC ANALYSIS AND BENEFIT ESTIMATION

Economic values are ordinarily based on market-determined prices and quantities. However, because fishing on the Colorado River is free of charge, other methods must be employed to determine the value of the resource to fishermen, or their "willingness to pay." This information could be estimated by directly asking fishermen how much they would be willing to pay to fish the river. A more objective method, however, is to infer willingness to pay from actual responses to other costs associated with the fishing experience. The most widely used and probably the best method is the travel-cost procedure. Developed and refined by Clawson and Knetch (1966), the travel-cost procedure has been used extensively to estimate values for various recreational activities (Martin et al. 1974, Brown and Nawas 1973, Burt and Brewer 1971). Gum and Martin (1975) used a derivation of the procedure in estimating values for various kinds of outdoor recreation (including fishing) in Arizona. The method is based on the fact that users experience a variety of costs because of differing travel distances. Consequently, rates of participation for a range of costs can be empirically determined. These participation rates are used to estimate the effects of different use fees on

---

<sup>1</sup>Paper presented at the First North American Riparian Conference (Tucson, Arizona, April 16-18, 1985).

<sup>2</sup>Merton T. Richards and D. Brent Wood are Associate Professors, School of Forestry, Northern Arizona University, Flagstaff, Arizona.

visitation. The resulting functional relationship between price and quantity defines demand and provides the information required to determine value.

#### Data Collection

Two survey methods were employed to facilitate data collection: on-site interviews and a mail survey. The on-site interviews obtained pertinent inputs to the demand analysis and also gathered visitor characteristics data. The mailed questionnaires supplemented the economic data and provided visitor perception and attitude inputs. Boating visitors to Lees Ferry were contacted at the fishery's only boat launching ramp. Anglers fishing from the shore were contacted there. In all, 845 groups of anglers were contacted from September 1982 through May 1983. One member from each of the groups was selected randomly and asked to participate in a mail survey. Of the anglers asked, 781 (94 percent) agreed and provided their addresses. Of 773 successfully delivered questionnaire mailings, 519 questionnaires were returned for a mail response rate of 67 percent. No follow-up methods were employed. Analysis was conducted on 511 usable responses.

Respondents were separated into two categories, trophy anglers and non-trophy anglers. This selection was based on responses to two questions on the mailed questionnaire and is described in a comprehensive report of this study.<sup>3</sup> Data were collected on respondents' variable costs for food, lodging and transportation expenses incurred on-site and while traveling to and from Lees Ferry. Respondents were also asked the amount of time they spent traveling to the site in order to include actual travel time, in hours, as an independent variable in the demand equations. On-site costs were added to travel costs, in dollars, as both an appropriate measure of trip cost and as a proxy for time on-site.

#### Regression Variables

Using multiple regression analysis the dependent variable (quantity demanded) is the number of trips per year to Lees Ferry made by individual angler households. This variable was regressed on independent variables representing costs (price) per trip, including time costs, and on certain categorical variables derived from the analysis of user differences.

<sup>3</sup>Richards, M.T., D.B. Wood, and D.A. Caylor. 1985. Details of survey, respondent characteristics, and data analysis. Unpublished final report to Northern Arizona University Organized Research Committee. School of Forestry, NAU, Flagstaff, AZ.

Three major cost variables were calculated for this analysis, variable on-site costs, variable travel costs, and the arithmetic sum of these two cost components. Mean values for these dollar costs per trip are separated by trophy and non-trophy categories and appear in table 1, along with mean number of trips per year.

Table 1.--Mean variable costs per trip and mean trips per year by trophy and non-trophy classifications

	Trophy (n = 122)	Non-trophy (n = 322)
Travel Costs (dollars)	42.32	33.78
On-Site Costs (dollars)	37.18	28.30
Total Costs (dollars)	79.50	62.08
Trips Per Year (number)	8	4

#### REGRESSION EQUATIONS

Regression equations were developed separately for trophy and non-trophy anglers using a stepwise regression procedure. Alpha levels for "t" statistics were set at 0.05 for inclusion of variables in the equations. Cases having a missing value for any regression value were dropped causing a reduction in the number of usable responses.

#### Trophy Anglers

The demand equation for trophy anglers is:

$$Y = 38.75 + 32.47x_1^{-1} - 8.151x_2 - 7.03x_3 - 8.78x_4 + 5.85x_5$$

(6.45) (10.07) (1.49) (3.21)  
(3.83) (2.61)

Where:

- Y = number of trips per year
- x<sub>1</sub> = total cost per trip in dollars
- x<sub>2</sub> = round-trip travel time in hours
- x<sub>3</sub> = angler success rating  
(1 = successful; 0 = not successful)
- x<sub>4</sub> = importance of scenic beauty  
(1 = important; 0 = not important)
- x<sub>5</sub> = angler fishing practice  
(1 = artificial only; 0 = all others)

Values in parentheses are the standard errors of the estimates. n = 122. Adjusted R<sup>2</sup> = .407.

Total cost per Lees Ferry trip, the major independent variable, appears in the equation as a reciprocal with a positive coefficient. This



indicates that as cost per trip increases, the number of trips taken per year decreases.

Round-trip travel time, the only other quantitative independent variable, appears in logarithmic form in the equation. With a negative coefficient, travel time also is inversely related to the number of trips taken; as travel time increases, number of trips decreases.

Three more variables appear in the trophy angler demand equation, all of them categorical variables. These variables will shift the demand function horizontally, but have no effect on its shape. However, they do improve the predictability of the equation.

#### Non-Trophy Anglers

The demand equation for non-trophy anglers is:

$$Y = 6.51 - 1.04 \ln x_1 + 2.16 x_2^{-1} + 2.53 x_3 - 1.49 x_4 - 1.76 x_5$$

(1.40) (0.31) (1.05) (0.74)  
(0.65) (0.71)

Where:

- Y = number of trips per year
- x<sub>1</sub> = total cost per trip in dollars
- x<sub>2</sub> = round-trip travel time in hours
- x<sub>3</sub> = angler success rating  
(1 = successful; 0 = not successful)
- x<sub>4</sub> = attitude toward reservation system  
(1 = approve; 0 = undecided or disapprove)
- x<sub>5</sub> = attitude toward catch and release designations  
(1 = agree; 0 = undecided or disagree)

Values in parentheses are the standard errors of the estimates. n = 322. Adjusted R<sup>2</sup> = .136.

Total cost per Lees Ferry trip, the major independent variable, appears in the logarithmic form with a negative coefficient. This indicates that as cost per trip increases, the number of trips taken per year decreases.

Round-trip travel time, again the only other quantitative independent variable in the equation, appears in reciprocal form with a positive coefficient. As in the trophy equation, the number of trips taken decreases as time spent traveling to and from Lees Ferry increases.

The non-trophy demand equation also has three categorical variables. The first of these, angler success rating, is the only categorical

variable common to both trophy and non-trophy equations.

Several variables failed to improve the fit of the demand functions. Among these were age and income, indicating that demand for fishing at Lees Ferry does not differ significantly between respondents of different ages or income levels.

#### BENEFIT ESTIMATION

The estimated demand functions permit the calculation of benefits enjoyed by anglers at Lees Ferry. In economic terms, the aggregate of such benefits is known as consumers' surplus. It is the maximum sum of money consumers would be willing to pay for a given amount of goods or service, less the amount they actually pay (Mishan 1976). For Lees Ferry anglers, then, consumers' surplus values represent the additional amount, in dollars, that they would be willing to pay rather than forego the fishing opportunities provided by this riparian resource. Mathematically, it is calculated by measuring the total area beneath a demand function, but above the area defined by the actual price or cost incurred for a good or service (recreational experience).

The demand functions proved to be highly inelastic. In other words, anglers at Lees Ferry are not very "price responsive"; increases in their costs of participation result in a less than proportional decrease in the number of visits they make. Significantly, trophy anglers are even less price-responsive than non-trophy anglers. Anglers at Lees Ferry, then, are very committed to pursuing their desired experiences and trophy anglers more so.

The demand functions were used to estimate the economic benefits received by anglers as a result of the fishing opportunities provided at Lees Ferry. Based on National Park Service visitation figures for 1982, an estimated \$5 million in benefits was enjoyed by all anglers. Approximately \$1.7 million accrued to trophy anglers and \$3.2 million to non-trophy anglers. The unit of analysis in this study was a family household. The annual value per household for trophy anglers was estimated to be more than \$3,000 and for non-trophy anglers nearly \$1,100. Also of significance is our finding that trophy anglers make an average of eight trips per year to Lees Ferry while non-trophy anglers average four trips per year. The benefits per trip for trophy anglers, then, is about \$380 as opposed to \$270 for non-trophy anglers.

In addition to the derived measure of benefits to Lees Ferry anglers, respondents surveyed in this study were asked their willingness to pay a special annual fee to fish at Lees Ferry on the condition that such fees would be used strictly for fishery improvements at Lees Ferry. The responses resulted in an average willingness to

pay value of nearly \$15. For trophy anglers the average response was almost \$22 and for non-trophy anglers about \$12.

#### MANAGEMENT RECOMMENDATIONS

Trophy trout fisheries are rare in the American Southwest, and Lees Ferry is regarded by many anglers to be the most highly prized of these. Indeed, some anglers travel across the nation to fish its waters. A resource of this quality would seem worthy of preservation, yet current management policies do not entirely address a worsening situation.

The Lees Ferry fishery is only a small part of a system of recreation opportunities. However, the number of recreation sites affording opportunities to catch ten pound rainbow trout is extremely limited. Because Lees Ferry can provide opportunities for such trophy fishing experiences, it is indeed a rare commodity. The demand functions estimated in this study show that, as a result, trophy anglers place a very high value on Lees Ferry.

We recommend managing Lees Ferry for the trophy anglers who have few, if any, substitute recreation sites. For the less critical anglers, many substitutes are available.

Our data suggest that non-trophy anglers are density-tolerant, that they like to catch the limit, and that they oppose artificial-only and catch-and-release areas. Arizona alone provides numerous fisheries which could satisfy these anglers. The trophy group, on the other hand dislikes crowding, is not concerned with number of fish caught, and supports restricted fishing areas. Managing Lees Ferry for trophy anglers requires two types of action. First, the fishery should be managed to provide a satisfactory number of trophy fish. This alone, however, is insufficient to ensure a high quality experience. Crowding is perceived as a major problem by trophy anglers and we believe policies

should be initiated to discourage users who have other alternatives available to them.

We recommend three regulation changes: (1) a creel limit reduction, (2) designation of catch-and-release areas, and (3) designation of artificial-only areas. We further recommend rationing angler use with an annual user fee of between \$5 and \$15. In conjunction with these actions, we believe that enforcement should be increased to ensure compliance with the changes. Additional enforcement costs could be financed through the user fee. These recommendations should reduce crowding while favoring trophy fishermen over those whose desires can be satisfied elsewhere.

#### LITERATURE CITED

- Brown, William G., and Farid Nawas. 1973. Impact of aggregation on the estimation of outdoor recreation demand functions. *Amer. Jour. Ag. Econ.* 55(2):246-249.
- Burt, Oscar R., and Durward Brewer. 1971. Estimation of net social benefits from outdoor recreation. *Econometrica* 39(5):813-827.
- Clawson, Marion, and Jack Knetsch. 1966. *Economics of outdoor recreation.* 328 p. Johns Hopkins Press, Baltimore.
- Gum, Russell L., and William E. Martin. 1975. Problems and solutions in estimating the demand for and value of rural outdoor recreation. *Amer. Jour. Ag. Econ.* 57(4):558-566.
- Martin, William E., Russell L. Gum, and Arthur H. Smith. 1974. The demand for and value of hunting, fishing, and general rural outdoor recreation in Arizona. *Ariz. Ag. Exp. Sta. Tec. Bull.* 211. 55 p. University of Arizona, Tucson.
- Mishan, E. J. 1976. *Cost-benefit analysis.* 454 p. Praeger, New York.

# A Wilderness Riparian Environment: Visitor Satisfaction, Perceptions, Reality, and Management<sup>1</sup>

Sharon L. Hoover, David A. King, and William J. Matter<sup>2</sup>

---

Abstract.--Visitors to the area were generally satisfied with their visits, but cited features associated with cattle, fishing and contact with other people as detractors. Their perceptions of the relative abundance of selected environmental conditions closely matched real-world measures. Attributes given the highest desirability ratings by the users were largely features likely to be prevalent in healthy riparian systems. Thus, management which maintains or enhances the ecological integrity of riparian areas may also contribute to their potential recreational values.

---

## INTRODUCTION

Relative to other land types, riparian areas are characterized by the combination of high species diversity, high species densities and high biological productivity. As noted by the Western Division of the American Fisheries Society (1980), the riparian zone is recognized as a very important and potentially valuable land type because: 1) it determines, in part, the quality of bordered aquatic habitats; 2) it provides a vegetative buffer zone for bottomland stability against overland water flows; 3) it offers more seasonal and year-long habitat to the greatest numbers and diversity of terrestrial wildlife populations than any other habitat type; 4) it accommodates and attracts important recreational activities; and 5) its pleasing combination of land, water, vegetation, and wildlife is very aesthetically valuable. Additionally, riparian areas can provide highly palatable forage for domestic livestock.

While riparian areas can provide for a multitude of potential uses, they are relatively limited in extent everywhere, and especially in the Southwest. Historically, the area of riparian ecosystems has always been small relative to other ecosystems. More recently, however, human encroachment and activities have further reduced the relative extent of these sensitive ecosystems, making those that remain even more significant. In the Southwest, domestic livestock grazing,

stream channel alteration, water pollution, recreational use, and urban development are primary factors contributing to the loss of riparian communities (Brinson, et al. 1981).

Given the social and ecological importance of riparian areas and their increasing relative scarcity, they must be very carefully managed for maximum net social benefits. To do this, it is necessary to have information about their values to society.

This study was designed to identify some of the benefits, in terms of satisfaction, that people obtain from recreating in a riparian environment within a designated Wilderness Area. In particular, we wanted to identify features in the environment that added to or detracted from visitor satisfaction. We also explored the relationships between visitors' perceptions of the desirability and commonness of environmental attributes and objective measures of those attributes.

## METHODS

### Study Area

The study area was located in the Mount Baldy Wilderness Area (MBWA) in east central Arizona, administered by the Apache-Sitgreaves National Forest. The Wilderness is 7,000 acres in size and ranges in elevation from 9,200 to 11,400 feet. Spruce-fir is the primary forest type with small stands of aspen scattered throughout. Two perennial streams, the West and East Forks of the Little Colorado River, form in and flow from the area.

Only a portion of the Wilderness, within the West Fork drainage, was included in the study. A trail parallels the meandering stream for about the first 2 miles, from the Wilderness boundary

---

<sup>1</sup>Paper presented at the Interagency North American Riparian Conference: "Riparian Ecosystems and Their Management: Reconciling Conflicting Uses." Tucson, Ariz. April 16-18, 1985.

<sup>2</sup>Sharon L. Hoover was Graduate Research Assistant, David A. King is Professor, and William J. Matter is Associate Professor in the School of Renewable Natural Resources, University of Arizona, Tucson, Ariz.

through several meadows. The next 4.2 miles of trail are steeper and enter densely forested areas.

In 1981, the estimated recreational use of the Wilderness was 5,000 visitor days, a density of 0.68 visitor days per acre. In 1975 the density of use was 0.65 visitor days per acre which, at that time, was the highest of any wilderness area in Arizona (Hendee, et al. 1978).

During the summer, the Arizona Game and Fish Department stocks the West Fork, just below the Wilderness boundary, with about 600 catchable-sized trout every week, but few of these fish become residents within the wilderness reaches of the stream.

Cattle grazing has taken place since about 1900. Typically, 300 cattle are put on the range in June and removed by late October. Every third year the pasture undergoes a complete rest.

#### Data Collection and Analysis

Three measures of visitor satisfaction were used. The first was a direct query as to their overall satisfaction with the trip and the second came from visitor ratings of their satisfaction with the following 12 attributes of the area.

Scenery  
Streams  
Forest  
Meadows  
Wildflowers  
People you are with  
Trails  
Wildlife  
Other people you encountered  
Fishing  
Trail signs  
Cattle

Seven point scales were used for both measures. Mean scores across respondents were used as estimates of overall visitor satisfaction with the trip and of satisfaction with the attributes presented for response.

The third index of satisfaction was Peterson's (1974) measure of relative congruity. This index is based on the hypothesis that satisfaction is a function of the degree to which there is congruency between a visitor's aspirations for, and perceptions of, the presence of the attributes in the environment. Aspirations were measured in terms of visitors' expressions of the degree of desirability of the attributes. Perceptions of the presence of the attributes in the environment were measured in terms of the visitors' expressions of the commonness of the attributes in the area. Desirability and perceived commonness also were measured with a 7-point scale.

Theoretically, satisfaction with a given attribute is maximized when the degree of desirability is congruent with the degree of perceived commonness (Peterson 1974). The measure of congruence is the difference in the mean standard scores for the desirability and for the perceived commonness of an attribute. A difference of zero indicates complete congruence and, theoretically, maximum satisfaction with the attribute. The statistical significance of the congruities of the attributes were tested with Student's t. Relative congruities were calculated for each of the following 34 attributes.

Mature, virgin forests  
Trails, with views  
Large, open meadows  
Trails within dense forests  
Streamside trails  
Primitive campsites  
Rock outcrops  
Knowing that you can get help  
Seeing no one but your own party  
Really big fish in the streams  
Registration boxes  
Opportunity to catch stocked trout  
Stream sections that easily yield fish  
Stretches of stream with no other anglers  
Steep trails  
Stream banks clear of trees and brush  
Fallen logs or trees across the trails  
Cattle grazing in meadows  
Areas where two trails run side by side  
Campfire rings left by other campers  
Shortcuts up and down switchbacks  
Cattle drinking from streams  
Trails that are deeply rutted  
People using non-motorized bicycles  
Cow manure along streams  
Cow manure in and near trails  
Cow manure in and around campsites  
Murky or discolored water  
Live trees with carving  
Water pollution  
Initials or names carved into signs  
Litter at campsites  
Litter along trails  
Litter along streams

Several environmental attributes and patterns of use vary along an upstream gradient within the study area. Visitors who travel different distances are exposed to different real levels of attribute commonness and, hence, would be expected to experience different levels of satisfaction as well. This variation in site conditions provided the opportunity to compare visitors' perceptions of the commonness of various attributes (cattle, litter, trail conditions, damage to vegetation, fish, and number of users) with objective measures of their commonness.

To control for and take advantage of this variation, the area was stratified into three units. The Lower segment was defined as the first 0.7 miles of the trail and contained most of the casual picnicking and sight-seeing. It is made up largely of small, narrow meadows, broken by small

stands of spruce and fir. The Middle segment was defined as the next 1.5 miles and included larger, broader meadows bordered by stands of spruce and fir. The Upper segment extended from mile 2.2 nearly to the crest, a distance of 4 miles, and wholly within very dense coniferous forest. Landmarks were used to make these delineations known to the respondents.

The objective measures of environmental conditions were made as follows. A total count of litter, damage to vegetation (carvings, hatchet cuts, stripped bark, exposed roots), and cow manure within 5 meters of either side of the trail was made twice during the summer. Similar counts of litter and manure were made along nine, 0.1-mile lengths of stream. Fish abundance was estimated from direct current electrofishing samples from a series of 5--meter sections of the stream throughout its course. Trail conditions (ruts, switchbacks, braids) were measured along the entire trail. The number of users reaching specific distances into the Wilderness area were estimated from full day visual counts at selected points and from visitor reports during interviews.

During July and August of 1983, 301 visitors were interviewed on-site: 90 who had experienced only the Lower segment, 87 who had experienced the Lower and Middle segments, and 124 who had experienced all three segments. Obviously, respondents could express their perceptions of attribute commonness only for trail segments they had experienced. Those who had experienced only the Lower segment or the Lower and Middle segments were asked only about those segments. Those who experienced all three segments were qualified to respond to all three, but this was considered too great a response burden and they were asked only about two of the segments, randomly selected.

## RESULTS

### Visitor Satisfaction

The direct measures of satisfaction indicate the visitors to the area were generally satisfied with their trip and with the particular attributes as well.

ATTRIBUTE	MEAN	STANDARD DEVIATION
Trip, overall	6.69	0.53
Scenery	6.83	0.45
Streams	6.79	0.49
Forest	6.68	0.70
Meadows	6.59	0.68
Wildflowers	6.56	0.75
People you are with	6.50	0.90
Trails	6.23	1.03
Wildlife	5.65	1.27
People encountered	5.05	1.39
Fishing	4.50	1.39
Trail signs	4.28	1.60
Cattle	3.66	1.90

While respondents indicated they were very satisfied with attributes such as scenery, streams and forests, they were dissatisfied with cattle, trail signs, fishing, and other people.

Open ended comments by the visitors sampled provided more insight into the causes of dissatisfaction with various attributes. Most of the respondents wanted to see more signs giving mileages to the crest, identifying plants, and providing general information about the wilderness area. Dissatisfaction with cattle was mainly caused by the odor and sight of manure. The quality of the fishing was considered unsatisfactory largely because of low success ratios. Dissatisfaction with other people in the area was caused by encounters that were too frequent to allow some sense of solitude.

Based on the relative congruity measure, the visitors also seem to be generally satisfied with the area. Only one attribute, "Cow manure in and near the trails", had a congruity score significantly different from zero at the 10 percent level.

### Attribute Desirability

The ten most and ten least desirable environmental attributes, in the context of the Mt. Baldy Wilderness Area, are shown below.

ATTRIBUTE	RANK
Mature, virgin forests	1
Trails with views	2
Large, open meadows	3
Trails within dense forests	4
Streamside trails	5
Primitive campsites	6
Rock outcrops	7
Knowing you can get help	8
Seeing no one but your own party	9
Really big fish in the streams	10

---

Cow manure in and near trails	25
People using non-motorized bikes	26
Cow manure in and around campsites	27
Murky or discolored water	28
Live trees with carving	29
Water pollution	30
Initials or names carved in signs	31
Litter at campsites	32
Litter along trails	33
Litter along streams	34

The attributes with the highest desirability include features nearly always present in relatively undisturbed riparian ecosystems while those with high undesirability include indicators of system degradation.

### Attribute Commonness

The rank of each of the segments according to the measured and perceived commonness of attributes within them are shown below. There is a strong positive correlation between perceived commonness and actual commonness of these attributes.

ATTRIBUTES	LOWER	MIDDLE	UPPER
Large, open meadows			
Actual	2	1	3
Perceived	2	1	3
Cow manure along trails			
Actual	2	1	3
Perceived	2	1	3
Litter along trails			
Actual	1	3	2
Perceived	1	3	2
Trails that are rutted			
Actual	2	1	3
Perceived	2	1	3
Litter in campsites			
Actual	2	3	1
Perceived	1	2	3
Shortcuts on switchbacks			
Actual	2.5	2.5	1
Perceived	3	2	1
Opportunity to catch trout			
Actual	1	2	3
Perceived	1	2	3
Litter along streams			
Actual	1.5	1.5	3
Perceived	1	1	3
Streamside trails			
Actual	1	2	3
Perceived	1	2	3
Vegetative damage			
Actual	2.5	2.5	1
Perceived	1	2	3
Cattle grazing in meadows			
Actual	2	1	3
Perceived	2	1	3
Cow manure in campsites			
Actual	1	2	3
Perceived	1	2	3
Braided trails			
Actual	1	2	3
Perceived	1	2	3
Density of use			
Actual	1	2	3
Perceived	1	2	3

### CONCLUSIONS

The primary sources of dissatisfaction expressed by visitors to the MBWA were related to undesirably high evidence of cattle and people. Satisfaction per visitor would be increased if the numbers of each of these animals were reduced.

The fact that only one attribute had a relative congruity score significantly different from zero at the 10 percent level probably indicates that the Mount Baldy Wilderness Area is providing satisfactory experiences for the people now using it. This result is not surprising, people tend to go to places that are satisfying to them.

Data on visitors' backgrounds (Hoover 1984), however, clearly indicated that even visitors with very limited outdoor experience and knowledge (and possibly expectations) penetrated the furthest reaches of the Wilderness, one indication that the area may not be supporting demand for wilderness dependent activities as defined by Hendee, et al. (1978, p. 146). If this is true, then the concerns of knowledgeable wilderness users are not strongly represented in the results of this study. We did find that visitors with education in natural resource fields or with higher levels of wilderness experience reported the greatest dissatisfaction with several of the environmental attributes. Thus, experienced recreationists or wilderness-obligate users (Hendee, et al. 1978), although only a fraction of the present user group, may represent a survey pool of more environmentally sensitive visitors and more likely to provide early warning to imminent management needs in this area. Further, if the area were enhanced environmentally through management of the resource and its use, the proportion of wilderness obligate users might be increased, which could possibly increase the total use benefits provided by the Wilderness.

The results indicate that those attributes desired by the visitors also were those attributes necessarily present in riparian ecosystems. And those attributes the visitors found to be undesirable are indicators of environmental deterioration. In other words, functional ecological values appear to be congruent with the preference related values of human beings with respect to this riparian environment. Furthermore, visitors' perceptions of the commonness of objectively measurable environmental attributes were generally in accord with reality. These are important conclusions for management. They mean that managing this environment, and the uses of it, to maintain and enhance its ecological health also will contribute to the value it holds for the visitors.

### LITERATURE CITED

- Brinson, M. M., B. L. Swift, R. C. Plantico and J. S. Barclay. 1981. Riparian ecosystems: their ecology and status. Final Report FWS/DBS-81/17. Eastern Energy and Land Use Team, USDI Fish and Wildlife Service.
- Hendee, J. C., G. H. Stankey, and R. C. Lucas. 1978. Wilderness Management. USDA Forest Service Misc. Publication No. 1365, 381p. Washington, D.C.
- Hoover, Sharon Lee. 1984. Levels and Sources of Satisfaction in the Mt. Baldy Wilderness Area. Unpublished M. S. thesis, University of Arizona, 88p. Tucson, Ariz.
- Peterson, George L. 1974. Evaluating the quality of the wilderness environment: congruence between perception and aspiration. *Environment and Behavior*. 6(2):169-193.
- Western Division of the American Fisheries Society. 1980. Management and protection of western riparian stream ecosystems: a position paper. American Fisheries Society, Bethesda, Maryland. 24p.

# Human Behavior and Recreation Habitats: Conceptual Issues<sup>1</sup>

Donald R. Field, Martha E. Lee, and Kristen Martinson

2

---

Abstract.--Individual recreation behavior and recreation experiences are more often than not determined by three sets of factors: the social group within which an individual participates, including the mix of social groups occupying a specific recreation place; the biological or physical characteristics of that place; and the management prescriptions applied there. Few studies have examined recreation behavior in the context of these three sets of factors. The present paper provides a conceptual framework to do so. The focus is upon human behavior and recreation habitats. Human ecological principles, along with concepts used to classify recreation "habitats" according to the recreation opportunities they provide, form the conceptual framework for the presentation.

---

## INTRODUCTION

Human behavior in recreation areas is largely a representation of culture, human experiences, the social group associated with the present recreation event, and conditions under which the current recreation event takes place. For some the above statement may strike a cultural deterministic cord. While not intended, the statement is made to reinforce the position that each of us has cultural baggage which frames our view of the world and guides the experiences (recreation and non-recreation) that we have. When a recreation group arrives at a recreation site, this cultural baggage will assist in the human adaptation to the facilities present, (management prescriptions) and the biological, physical, and social environments. The purpose of the present paper is to describe a conceptual

framework which acknowledges the interplay of human culture, social groups, and natural resource systems in defining human behavior at a recreation site. This framework is based upon human ecology and incorporates a recreation planning and management perspective called the Recreation Opportunity Spectrum (ROS). The conceptual framework emphasizes the creation of leisure settings from the blending of human behavior (culture and social organization) with recreation places, the management system described by the Recreation Opportunity Spectrum (ROS). The benefits of our approach yield both a more holistic understanding of people, the dimensions of human behavior in recreation environments, and an understanding of management options for monitoring a recreation system, measuring human response to management actions, and resolving social conflicts and human impacts on the environment. This framework is guiding our research on recreation behavior associated with the riparian zone. Our research is being conducted at the Whiskeytown Unit of the Whiskeytown-Shasta-Trinity National Recreation Area.

---

<sup>1</sup>Paper presented at the First North American Riparian Conference (Tucson, Arizona, April 16-18, 1985).

<sup>2</sup>The paper is part of a human resource inventory project at the Whiskeytown Unit of the Whiskeytown, Shasta, Trinity N.R.A. Funds for the project provided by the Science Division, Western Region, National Park Service, through a Cooperative Agreement (Subagreement No. 5) to Oregon State University, College of Forestry.

<sup>3</sup>Donald R. Field is Senior Scientist, National Park Service, Coop. Park Studies Unit and Professor, College of Forestry; Marty Lee is Research Associate, Dept. of Resource Recreation Management and NPS Coop. Park Studies Unit; and Kristen Martinson is Research Assistant, NPS Coop. Park Studies Unit, Oregon State University, Corvallis.

## DEFINING A CONCEPTUAL FRAMEWORK

Human ecology shares its development with plant and animal ecology, geography, sociology, anthropology, and demography. Each discipline has helped to refine the definition and relationship of people to their environment incorporated within the human ecological paradigm. Human ecology will not be defined here. There are excellent state-

ments about human ecology such as Human Ecology: A Theory of Community Structure (Hawley 1950), Social Morphology and Human Ecology, (Schnore 1958), and Land Use in Central Boston, (Firey 1947). The history of human ecology as a field of study is well described in Urban Patterns: Studies in Human Ecology (Theodorson 1982). Recent work such as The Ecological Transition (Bennett 1976) and Overshoot (Catton 1982) reaffirm the basic tenants of the theory and relationship of people, human behavior and natural resources.

For our purpose the key to the ecological perspective is as follows:

- a. The framework acknowledges humankind as part of the natural world.
- b. The interconnectedness of behavior and environment is depicted by the human ecosystem.
- c. All human interrelationships are social with culture and biotic components inseparable in analysis.
- d. Social and ecological change is acknowledged as having ramifications for all components of the system.
- e. The unit of analysis is community structure/social structure.

The application of the human ecology theory to recreation behavior has been made (Machlis et al. 1981), but further elaboration is appropriate. Human ecology stresses the interplay of homo sapiens and natural resource systems. The environmental basis for social organization is a central issue for human ecologists and is especially important for those of us studying recreation behavior in parks and forests. In every recreation situation both management and the visitor are in their own way molding or creating a social environment. Sometimes these social environments are similar, in other cases not.

Nevertheless, social environments are created by people in the manner in which they adapt to the biophysical environment and the social meanings shared within those environments. No matter how temporary, a social order and social organization is established by people which governs the behavior of the people present. Firey (1945) suggests culture and cultural display are key factors in the creation of these social environments. Cultural display such as the language used by occupants, the manner of dress, the technology (i.e., beer bottles and ice cooler, backpacking or other camping gear, climbing equipment), art forms and music, to name but a few cultural objects, are all present in recreation environments. Cultural objects and symbolic values attached to places help define appropriate behavior and the kind of people who are welcome. While not the central thrust of the article, DeVall's (1973) description of mountain climbers in a Yosemite campground, for example, is representative of the conversion of a

recreation place into a social environment. Here language and equipment together provide guidance to one's ability to enter and become part of the social world. Family reunions in Olympic National Park's Klaloch campground each year likewise reflect the conversion of a recreation place into a social environment where social meanings of family togetherness reinforce the commitment of multiple generations of the same family to each other. The social environment is a family gathering, the campground a backdrop for the activities occurring. Campsites and rules are modified by family members to ensure that a social environment for the family is secured. Nonfamily entering this camping loop soon learn there are other more accommodating campsites down the road. Lee's (1972) description of an ethnic group's definition of a park and subsequent visit hinges on the ability of these people to create a social environment consistent with their values and definition of resources within the park they are visiting. Recent work by Edgerton (1979) illustrates how some biological/physical environments such as beaches can simultaneously accommodate drug dealing and use, courtship, family activities and picnics, nude bathing, and games of sport. Visitors include blacks, hispanics, whites, gay families, single parent families, two-parent families, teenagers, retired adults, and representatives of the baby boom generation. Social environments for each are established usually without interference from another social environment.

Ecological descriptions of social environments have led to the description of the contrived community (Suttles 1982), the defended neighborhood (Suttles 1972), and the rural neighborhood (Kolb 1959). A similar perspective is employed here to describe leisure settings. Leisure settings are the social environments created by people as they apply their particular brand of leisure lifestyle to a recreation place; as they transport or superimpose their culture upon a recreation place; or as they create a particular leisure or recreation experience within a recreation place (Cheek, Field and Burdge 1976).

Recreation places are those "habitats"--watersheds, bays, shorelines, picnic areas, campgrounds, parking lots, roadside pullouts, restaurants, subalpine meadow campsites, lake campsites, etc., created in part by a land management agency, accommodating human use. These places may have intended recreational value given by management, but until people occupy and adapt to the space provided, social environments or leisure settings do not occur. There can be numerous recreation places within designated recreation areas such as national parks and forests, just as there can be numerous leisure settings established within and among recreation places.

The recreation place people choose to visit can influence and somewhat define the activities they choose as well as the behavior and subsequent experiences that may occur there. The recreation place and its potential influence on recreation experiences is the focus of the Recreation Opportunity Spectrum (ROS). ROS is a framework



for understanding the relationship between recreation experiences and the environment. ROS defines a range or spectrum of recreation opportunities ranging from primitive to urban that land managers can provide to meet a diversity of visitor preferences (Buist and Hoots 1982). This concept is based on the assumption that quality in outdoor recreation is best assured by providing a diversity of recreation opportunities (Clark and Stankey 1979), an idea suggested in early research on recreation users (e.g., Shafer 1969; Wagar 1966; King 1966). Operationalized, ROS is a system which enables public or private recreation managers to inventory and classify land and water areas according to their capability to provide recreation "potential" as defined within the agency guidelines. Both the USDA Forest Service and USDI Bureau of Land Management have adopted a planning system (Recreation Opportunity Planning) which uses the ROS to inventory and manage their recreation resources (Buist and Hoots 1982).

The focus in ROS is on the recreation place. The variety in types of recreation places an area provides represents the choices people have when considering outdoor recreation opportunities. ROS recognizes that the experiences derived from recreation are related to the places or locales in which they occur but are not determined by them (Clark and Stankey 1979). Recreation opportunity places, as described by ROS, are composed of three primary elements: the physical attributes--natural features such as vegetation, bodies of water, and topography; the social environment--the numbers and types of people and activities present; and the management prescription--the level and types of development, rules, and regulations provided by managers (Clark and Stankey 1979; Stankey and Brown 1981). These elements, existing in various combinations, can be used by managers to provide diversity in recreation opportunities. It is these elements over which they have most control. By offering a variety of "combinations" of such elements where

recreationists can pursue a variety of activities (social and physical), recreation managers can provide for the widest possible achievement of desired experiences.

Though ROS can be used by land managers to describe what a particular recreation place is like and what visitors might expect to find there, it cannot describe or predict an individual or group's choices, behavior, or subsequent experiences that will occur at a particular recreation place (Clark 1982). Figure 1 describes the relationship between people, culture and human behavior and the bio/physical environment. In addition, it illustrates that recreation places are provided by management and that leisure settings result from the joint interaction of people, culture and those recreation places.

#### REVIEW OF LITERATURE

The literature on water-based recreation which addresses the interaction of human behavior and bio/physical environment is limited. Social science research on water-based recreation has, however, generated several key findings which support the conceptual framework we have outlined.

Leisure activities oriented around water resources make up a considerable portion of all recreation participation. "Water is probably the greatest of all outdoor recreational attractions" (Lime 1975). People seek out water resources not only for direct recreational use such as swimming or boating but also as an aesthetic background for non-water oriented activities. A study of water-based recreation by residents in western Washington, western Oregon, and northern California identified that activities of observing nature, visiting the beach, and beachcombing comprised a large percent of all water-oriented recreation (Field and Cheek 1974).

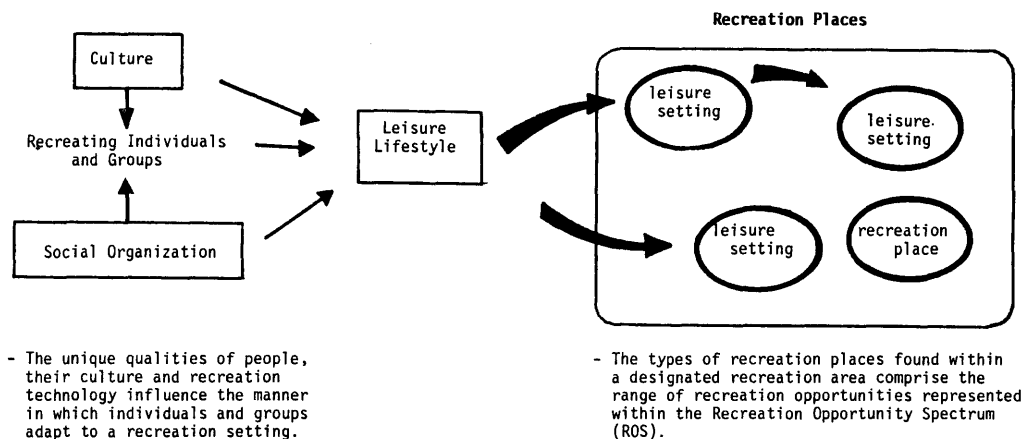

Figure 1. The relationship of people and recreation places for creating leisure settings.

## Location of Use

Water-based recreation occurs in a variety of different places and includes a wide range of activities. Water resource areas may differ considerably in setting attributes but they all have the common characteristic of water. Consequently, an activity such as swimming can be common among the most diverse resource settings and it is erroneous to assume that such activities are area-specific (i.e., kayaking only on rivers or swimming only at the beach) (Field and Cheek 1974).

It is interesting, however, to note some general trends. McDonough and Field (1979) identified the distribution of outings among water resources in a survey of Washington residents. Lakes received considerably more use than any other water resource type. Reservoirs, followed by rivers, were the next most often used areas. A small percent of outings occurred at the ocean. The most common activities occurring at each of these areas were also identified. Swimming, powerboating, sailing, canoeing, and fishing all occurred primarily at lakes, followed by reservoirs in considerably smaller percentages. Beachcombing also took place most often at lakes, followed closely by the ocean.

## Recreation Places and Water Resources

There are essentially three types of water resources based on their characteristics: rivers and streams (running water), lakes and reservoirs (standing fresh water), and beaches adjacent to oceans or large lakes. Differences in resource attributes, such as screening from other users due to topography or vegetation, give rise to differences in social norms dictating appropriate types and amounts of use. A variety of activities take place at all water environments though some are unique to a particular setting (e.g., surfing at the ocean) and obviously some water resources are more conducive to particular activities than others. McDonough (1980) points out in her study of lake users that though activity is a primary reason for choosing a specific place to recreate, there are many other influencing factors. Differences and similarities in activities are examined for each of the three water resource types.

Common activities on rivers and streams include fishing, tubing, river running, and swimming. The definition of any one of these activities, as with most recreation activities, may vary considerably depending on the degree of individual involvement. A single activity such as fishing can actually consist of a continuum of involvement levels ranging from generalized participation to specialized style (Bryan 1977). Fly fishing for trout in a high mountain stream and bait fishing for salmon in a coastal river are very different activities. This variation within any one activity must be kept in mind when generalizing about river or any water resource use.

In general, because of the secluded nature of river ways, many users prefer and expect few encounters with other groups while traveling on the river, particularly in wilderness areas (Schreyer et al. 1976, Shelby and Nielsen 1975, Heberlein and Vaske 1977, Tarbet et al. 1977). Most river systems provide considerable screening from other river users due to winding channels, thick bank vegetation, and often steep, narrow corridors. There may be several groups floating a particular waterway who would not see each other all day if they were traveling at the same speed and sufficiently separated for the particular setting. However, for a visitor who is stationary, such as a fisherman on the bank, contacts with floaters could be numerous because the river would continually bring groups into and out of view (Heberlein and Vaske 1977).

Lakes and reservoirs do not provide as much screening from other users as do river ways. Thick vegetation may provide seclusion from other groups around the shoreline but the nature and shape of lakes provide prime exposure of most users on the water and on opposite shores.

Lakes and reservoirs can often provide opportunities for a wider variety of activities than rivers or ocean beaches. Common activities include swimming, fishing, waterskiing, powerboating, sailing and canoeing. McDonough (1980) found that primary reasons for visitors choosing to recreate at a lake resource were presence of friends, proximity, solitude, and water quality--pursuit of specific activities being less important.

Beaches are water oriented recreation places, often with irregular shorelines and open spaces that accommodate a wide variety of use. Beaches are popular environments for both water and non-water recreation activities, with many users spending the majority of their visit out of the water. Common recreation activities include surfing, sail boarding, swimming, boating, sunbathing, team sports (e.g., volleyball or football), kite flying, and beach combing. Visible evidence of management activities (e.g., lifeguards or food concessions) are often more acceptable at beaches than at other water settings.

People visiting beaches often expect to encounter others, and in fact, some social groups depend on density of use to secure privacy, while others seek the outside contacts that beaches may provide (Hecock 1970). A wide variety of social groups visit beach areas, and of the three water settings, beaches are where one would most likely find individuals recreating alone.

## SUMMARY

Understanding the relationships between behavior, culture, leisure lifestyle and recreation places is an important step in recreation research. There has been considerable research done on specific aspects of recreation behavior, but little which attempts to understand the joint interaction of behavior and habitat. Indeed, the

social organization of leisure behavior in parks and forests is as complex and sophisticated as the social organization of an urban neighborhood.

The conceptual framework presented here is another step in describing this human/biological picture. From here we can begin to examine related resource management issues such as assessing social impact, social conflicts and carrying capacity, and predicting visitor response to management actions. Using this perspective we can better understand the dynamic nature of various recreation places to accommodate a variety of visitors engaging in a wide diversity of activities across time and space.

#### LITERATURE CITED

- Bennett, J. 1976. *The Ecological Transition: Cultural Anthropology and Human Adaptation*. Pergamon Press, Inc. New York.
- Bryan, H. 1977. Leisure value systems and recreational specialization: The case of trout fishermen. *J. of Leisure Research* 9(3):174-187.
- Buist, L. J. and T. A. Hoots. 1982. Recreation opportunity spectrum approach to resource planning. *J. Forestry* 80(2):84-86.
- Catton, W. R., Jr. 1982. *Overshoot: The Ecological Basis of Revolutionary Change*. University of Illinois Press, Urbana, Ill.
- Cheek, N. H., D. R. Field, and R. J. Burdge. 1976. *Leisure and Recreation Places*. Ann Arbor Science, Ann Arbor, MI.
- Clark, R. N. 1982. Promises and pitfalls of the ROS in resource management. *Australian Parks and Rec.*, May, pp. 9-13.
- Clark, R. N. and G. H. Stankey. 1979. The recreation opportunity spectrum: A framework for planning, management, and research. USDA For. Serv. Gen. Tech. Rep. PNW-98. 32 p.
- DeVall, W. 1973. Social worlds of leisure. Pp. 131-144 in *Leisure and Recreation Places*. Edited by N. H. Cheek Jr., D. R. Field, R. J. Burdge. Ann Arbor Press. 1976.
- Edgerton, R. B. 1979. *Alone Together: Social Order on an Urban Beach*. Univ. of California Press, Berkeley.
- Firey, W. 1945. Sentiment and symbolism as ecological variable. *Am. Sociological Review* 10(April):140-148.
- Firey, W. 1947. *Land Use in Central Boston*. Harvard Univ. Press. Cambridge.
- Field, D. and N. H. Cheek, Jr. 1974. A basis for assessing differential participation in water-oriented recreation. *Water Resources Bulletin* 10(6):1218-1227.
- Hawley, A. 1950. *Human Ecology: A Theory of Community Structure*. The Ronald Press, New York.
- Hecock, R. D. 1970. Recreation behavior patterns as related to site characteristics of beaches. *J. of Leisure Research* 2(4):237-250.
- Heberlein, T. A., and J. J. Vaske. 1977. *Crowding and conflict on the Bois Brule River*. Water Resources Center Tech. Rep. WIS WRC 77-04. Madison, Wisc.
- King, D. A. 1966. Activity patterns of campers. USDA For. Ser. Res. Note NC-18.
- Kolb, J. 1959. *Emerging Rural Communities: Group Relations in Rural Society*. Univ. of Wisconsin Press, Madison.
- Lee, R. 1972. The social definition of outdoor recreation places. Pp. 68-84 in *Social Behavior, Natural Resources and the Environment*. Edited by William Burch, Jr., Neil H. Cheek, Jr. and Lee Taylor. Harpers Row, New York, New York.
- Lime, D. 1975. Backcountry river recreation: Problems and research opportunities. *Naturalist* 26(1):2-5.
- Machlis, G. E., D. R. Field, and F. L. Campbell. 1981. The human ecology of parks. *Leisure Sciences* 4(3):195-212.
- McDonough, M. H. 1980. *The influence of place on recreation behavior: The case of northeast Washington*. Ph.D. Dissertation, Univ. of Washington, Seattle.
- McDonough, M. H. and D. R. Field. 1979. *Coulee Dam National Recreation Area: Visitor use patterns and preferences*. NPS Univ. of Washington, Seattle.
- Schnore, L. 1958. Social morphology and human ecology. *American Journal of Sociology* 63(May):620-24, 629-34.
- Schreyer, R., J. W. Roggenbuck, S. F. McCool, L. E. Royer and J. Miller. 1976. *The Dinosaur National Monument whitewater river recreation study*. Institute for the Study of Outdoor Recreation and Tourism, Utah State Univ., Logan.
- Shafer, E. L., Jr. 1969. The average camper who doesn't exist. USDA For. Ser. Res. Pap. NE-142.
- Shelby, B. and J. M. Nielsen. 1976. Use levels and crowding in the Grand Canyon: River contact study. Final Report Part III. Grand Canyon National Park, Arizona.
- Stankey, G. H. and P. J. Brown. 1981. A technique for recreation planning and management in tomorrow's forests. Pp. 63-73 in *Proceedings XVII IUFRO World Congress, Japan*.
- Suttles, G. D. 1972. *The Social Construction of Communities*. Univ. of Chicago, Chicago.
- Suttles, G. D. 1982. The contrived community: 1970-1980. Pp. 224-230 in *Urban Patterns: Studies in Human Ecology*, George Theodorson. Penn. State Univ., University Park.
- Tarbet, D., G. H. Moeller, and K. T. McLoughlin. 1977. Attitudes of Salmon River users toward management of wild and scenic rivers. Pp. 365-371 in *Proceedings: River Recreation Management and Research Symposium*. USDA For. Ser. Gen. Tech. Rep. NC-28. North Central For. Exp. Sta. Minneapolis, MN.
- Theodorson, G. 1892. *Urban Patterns: Studies in Huma Ecology*. Penn. State Univ. Press, University Park.
- Wagar, J. A. 1966. Quality in outdoor recreation. *Trends in Parks and Recreation* 3(3):9-12.

# Riparian Vegetation and Indigenous Southwestern Agriculture: Control of Erosion, Pests, and Microclimate<sup>1</sup>

Gary Paul Nabhan<sup>2</sup>

---

Abstract.--Native American and Spanish American farmers of the arid Southwest have managed riparian vegetation adjacent to their agricultural fields for centuries. They have planted, pruned and encouraged phreatophytic tree species for flood erosion control; soil fertility renewal; buffered field microclimates and fuel-wood production. These practices benefit wildlife and plant genetic diversity.

---

## INTRODUCTION

Of the numerous studies of human impacts on riparian communities of the arid Southwest, several have critically analyzed the effects of modern agricultural use of water and land on riparian biota (Rea 1983; Reichhardt et. al. 1978; Johnson, 1979). Many riparian ecologists have attempted to compare human-disturbed sites with so-called "natural controls" which are assumed to be the kinds of ecosystems present in the region prior to the impact of modern man and his technologies (Barclay 1979; Conine et. al. 1978). Although bird and/or mammal species diversity appears higher in riparian woodlands than in field crops (Conine et. al. 1978) or in degraded woodlands simplified by phreatophyte control, the highest bird densities and diversity have been recorded in homogeneous cottonwood stands adjacent to field crops (Carothers et. al. 1974).

In fact, many of the so called "natural riparian stands" are sites which were in part formerly cultivated on a small scale by native Americans (Nabhan et. al. 1982). Prehistorically, irrigation systems of considerable size were developed on the Salt, Gila and Santa Cruz Rivers in Arizona (Masse 1981); and with aboriginal depopulation, some of them were abandoned and reverted to the "natural areas" studied by ecologists today. Cottonwoods, willows and elderberry are among the phreatophytic trees intentionally planted by native and Spanish American at the Quitobaquito oasis in Organpipe Cactus National Monument (Anderson et. al. in press) and along the intermittent streams of northeastern Sonora, Mexico (Nabhan et. al. 1982). Some of these artificially

planted riparian stands found near fields have been mistaken by Anglo observers as "natural stands" (Nabhan and Sheridan 1977).

From ethnobiological studies done in remnant areas of indigenous agriculture, it appears that small intercroppings of domesticated and weedy annuals formed mosaics with living hedges, taller shelterbelts, vegetation-reinforced earthen ditch-banks, and open surface water (Rea 1979; Reichhardt et. al. 1983). These habitat mosaics certainly encouraged biotic diversity to a greater degree than do modern monocultural fields plowed from concrete canal clear to the nearest road or next canal. Indigenous farmers recognize certain benefits of this structural diversity of habitat, and associated biotic diversity (Nabhan and Sheridan 1977; Nabhan 1983). The following summary highlights the benefits derived from riparian plants integrated into native agriculture of the arid Southwest, particularly in the U.S./ Mexico borderlands of the Sonoran Desert.

## SOIL EROSION CONTROL

Among of the major efforts made by prehistoric and historic communities in the arid Southwest were attempts to buffer themselves and their field crops from the effects of floods of short duration. Except for the last few centuries of the prehistoric era when bajadas and mountainside terraces were used for the cultivation of perennials such as agave, most native agriculture and horticulture were localized on floodplains. Where older patterns of land use and water control still persist in the region, one can see the traditional use of riparian vegetation as a buffer against floods. From the Tarahumara villages of the Rio Conchos, Chihuahua, through the intermittent streams of northeastern Sonora, clear to the Quitovac oasis in northwestern Sonora, native farmers weave brush between the trunks of lines of cottonwood, willow and mesquite adjacent to their floodplain fields to break the force of floods (Sheridan and Nabhan 1979; Nabhan 1983). This process of using living

---

<sup>1</sup>Paper presented at the international conference, "Riparian Ecosystems and Their Management: Reconciling Conflicting Uses," Tucson, Arizona, April, 16-18, 1985.

<sup>2</sup>Dr. Gary Paul Nabhan is Research Associate, Office of Arid Lands Studies, University of Arizona, 845 North Park Ave., Tucson, AZ 85719

fencerows as permeable weirs to reduce the erosive force of floods is still practiced extensively in northeastern Sonora, from 31°N - 29°30'N, and from 111°-109°W (Sheridan and Nabhan 1979; Nabhan and Sheridan 1977).

During the winter months, farmers cut branches of cottonwood (*Populus fremontii*) and willow (*Salix goodingii*), and plant the pruned, trimmed branches 1.5m deep and 0.5-0.75m apart at field margins on the edge of the most recently developed stream channel. These cuttings sprout by March, set down roots which stabilize the field edge, and grow into large trees which are periodically, removed for fuelwood. Between their trunks, brush of seep willow (*Baccharis salicifolia*), burrobush (*Hymenoclea* spp.); and mesquite (*Prosopis Juliflora*) are woven to form a horizontal, semipermeable barrier 1-2 m high.

This woven fence serves to slow later flood waters without entirely channelizing the primary streambed the way in which concrete or riprap channel banks would. As a result, when summer or winter floods arise which cover the entire first terrace of flood-plains, channels do not become as readily entrenched, nor is erosion as pervasive as it would be on a barren floodplain. December 1978 floods were responsible for five million dollars worth of crop, public works and machinery damage on a section of the Rio Magdalena lacking living fence rows and dozens of hectares have not yet been brought back into cultivation there. The same floods destroyed sections of living fencerows near Cucurpe on the Rio San Miguel and near Mazocahui on the Rio Sonora, and scouring was locally significant, but neither as profound nor pervasive. Within two years, farmers had made efforts to repropagate fencerows, and refill incipient headcuts running through fields from side drainages. While not foolproof, the hundreds of kilometers of propagated cottonwood and willow corridors in eastern Sonora work best in buffering fields from floods smaller in magnitude than 20 year events.

Soil Conservation Service projects near Safford on the Gila River and Canyon de Chelly on the Navajo Reservation once planted cottonwoods and willows to reduce bank erosion and lateral cutting associated with meanders. Although theoretically such woody riparian vegetation can bring stream channel erosion and aggradation into local equilibrium (Hadley and King 1977), I urge geomorphologists to set up studies to monitor the effects of these plantings in "real life situations" in eastern Sonora. Nevertheless, Sonoran farmers are correct when they say, "The trees and woven branches accept the floodwater and make it tame."

#### SOIL FERTILITY RENEWAL

Farmers in eastern Sonora claim that such semipermeable weirs of riparian vegetation "give soil to the fields" by trapping the rich detritus and silt suspended in floodwaters (Sheridan and Nabhan 1979). By placing now living fencerows

several meters into an eroded channel from an older row on a field bank, they force modest sized floods to drop their suspended bedloads as food energy is dissipated by hitting the woven brush. Some of this detritus and silt fills up in the place between the bank and the new fencerow; if flood levels are high enough, the rest slowly spreads out across the field. As one farmer in Cucurpe declared, "The floodwater's detritus is the richest, best material for fertilization." A San Ignacio, Sonora farmer claimed his field would yield well for four years following the fencerow mediated deposition of abono del rio (river manure/nutrients).

I had the opportunity to test this hypothesis while studying the desert riparian ecosystems which nurture Papago Indian floodwater fields (Nabhan 1983). The impermeable weirs which Papago farmers now build at strategic locations on or above alluvial fans play much the same role as the living fences in eastern Sonora; before barbed wire, Pima and Papago farmers lined their oval fields with dense hedges of mesquite (*Prosopis* spp.) and wolfberry (*Lycium* spp.)

Analyses published elsewhere (Nabhan 1984) verify that floodwashed detritus deposited in fields is as rich in nitrogen and certain other nutrients as are commercial organic fertilizers. A composite of debris from 14 plant species, including 5 legumes, and dung of 3-5 mammal species, this desert riparian detritus is rapidly decomposed in fields, where it contributes to plant growth and soil moisture holding capacity. The effects of this managed deposition of soil fertility is unequivocal. Nearly all Papago fields receiving organic floodwash from ephemeral streams maintained levels of soil macronutrients comparable to those recommended for commercial crop production, and need amendments only for one or two micronutrients that were geologically scarce in their watersheds. Fields that had been periodically cultivated at least since early historic times were not significantly less fertile than nearby, uncultivated floodplain soils (Nabhan 1983). The nitrogen rich detritus of mesquite and other desert riparian legumes probably have played a key role in floodplain soil fertility in the Sonoran Desert for millenia.

#### FIELD MICROCLIMATES

In arid and semiarid zones, the free exposure of irrigated herbaceous crops to hot, dry winds creates an evaporative pull resulting in extremely high transpiration rates (Carder 1961; El Rahman and Batanouny 1965). This herbaceous crop water loss can be diminished by planting windbreaks to reduce the clothesline or oasis effect over the crop canopy (Lomas and Schlesinger 1971). Particularly when the windbreak trees are tapping moisture reserves unavailable to crop roots, water savings from the crops far outweighs the losses from the trees. In effect, this system has been implemented by Sonoran farmers who greatly benefit from the microclimate buffering at springfed oases and along floodplain corridors. Temperature

control, wind control, and partial shading interact to moderate crop microclimate. In windspeeds of 20 mph, a 20 foot tall living windbreak can reduce wind velocity 80 feet into fields by 40%, reducing evaporation and pollination losses (Al-Mutawa 1985). A more favorable crop microclimate probably translates into yield increases, but these interactions have not been empirically studied in the Sonoran Desert.

#### FUELWOOD PRODUCTION

Except for mesquite, which is a highly marketable firewood, none of the commonly propagated Sonoran Desert riparian species have much market value. However, cottonwood and willow prunings are used as kindling and for short-duration cooking fires by the families of the farmers who seasonally trim the fence rows. Because fuelwood resources are rapidly being depleted in arid zones globally, these local renewable energy resources should not be overlooked.

#### PEST CONTROL

Mesquite and hackberry hedgerows with brush woven between served farmers historically in excluding livestock from their fields. Now barbed wire fulfills this function, but hedges and fence rows act as a secondary barrier. More importantly perhaps is the control of insect pests by insectivorous birds which nest or perch in the planted trees and understory. For instance, the Quitovac oasis harbored 29 insectivorous bird species in late Spring, 1982, more than any of the five other agricultural and natural vegetation sites studied by our Man and the Biosphere project (Reichhardt et. al. 1983). This site had a variety of hedge and fencerow features, as well as open water. Yet in three of the four seasonal censuses we made, the agricultural Quitovac oasis had more insectivores than non-agricultural Quitovaquito that also had open water. Overall, Quitovac had a higher Shannon-Weaver diversity value for passerine birds, including many insectivores, for three out of four seasons when compared with Quitovaquito (Reichhardt et. al. 1983). Obviously, empirical studies of insect populations and crop pest species are justified.

#### WILDLIFE

The above discussion suggests that fencerow habitats positively influence the diversity of bird species present in agricultural habitat mosaics within riparian ecosystems. Amadeo Rea observed that at the 6 Sonoran Desert sites which we studied, we found the following species only at farms adjacent to mesquite thickets: Crissal Thrasher; Northern Cardinal, Pyrrhuloxia, and Abert's Towhee. Rea also noted ten transient species attracted to the cool, shady microhabitats of fencerows: Epidonax flycatchers; Nashville, Yellow-Throated and Black-throated Warblers; Blue Grosbeaks; Lazuli Buntings; Pine Siskins; Savannah sparrows; Scott's Orioles, and Lincoln's sparrows

(Reichhardt et. al. 1983). His earlier hypothesis (Rea 1979) that these microhabitats also support a higher diversity of small mammals was not clearly documented, in part due to habitat destruction during our study. Eric Mellink, the vertebrate ecologist on our project, is currently studying seven rodent species inhabiting non-irrigated fields on floodplains in San Luis Potosi, Mexico. It is clear from avifaunal analyses of prehistoric agricultural habitats in the Rio Grande river basin (Emslie 1981) and from recent studies of mammals and birds in Midwestern shelterbelts (Yahner 1983 a and b) that woodland and field mosaics support considerable wildlife, including numerous species valued by hunters.

#### WILD GENETIC RESOURCES

One hidden benefit to Southwestern agriculture of adjacent riparian vegetation is the harboring of wild plant genetic resources in the understory of floodplain bosques, fencerows and shelterbelts. These genetic resources, largely cross-compatible relatives of native American crops, are strongly associated with riparian vegetation from the U.S./ Mexico borderlands, Southward. Through introgressive hybridization, these flood disturbance adapted plants contribute genes for tolerance to environmental stress, pests and diseases to crop plants with which they share pollen vectors. Laura Merrick, Steve Buchmann and I have begun to document this phenomena in detail at Pima Indian fields on the Rio Yaqui floodplain, where wild Cucurbita Soronia group populations outcross with the Cushaw squash, Cucurbita mixta (Nabhan 1984; Merrick and Nabhan 1984). Introgressive hybridization between Southwestern crops and riparian understory plants potentially occurs among chiles (Capsicum), beans (Phaseolus), maize (Zea), devil's claw (Proboscidea), amaranthus (Amaranthus), sunflowers (Helianthus) and introduced Songhums (Sorghum). Recently initiated efforts to study such introgressive hybridizations in indigenous agriculture in Arizona and northwest Mexico will undoubtedly result in more evidence that riparian biotic diversity has positive benefits for agricultural genetic diversity. Clearing away wild vegetation around native fields has begun in Onavas and Quitovac, Sonora, as part of government-subsidized agricultural development programs. This land use change, if continued, will likely isolate crops from the wild plant gene pools that have enriched them over evolutionary time, resulting in increasing genetic vulnerability of the crops.

#### CONCLUSIONS

The above-mentioned interactions between small-scale native agriculture and riparian vegetation in the binational Southwest present a different relationship than that occurring amidst modern, mechanized agriculture. The benefits to the diversity and stability of native agriculture are difficult to assess in monetary or energetic terms, but are nonetheless significant. I urge other scientists to apply their expertise and tools to the study of riparian vegetation mosaics and

and corridors interspersed with agricultural fields. Such studies may help us better appreciate 2500 years of native, floodplain-based agriculture in the binational Southwest, and may encourage us to reconsider overlooked options for future floodplain land use.

#### ACKNOWLEDGEMENTS

This research and writing was supported by the C.S. Fund, by NSF grant BNS-8317190, by the Wenner-Grenn Foundation, by U.S. Man and the Biosphere Program assistance via the USDA Forest Service, and by a Border States University Consortium travel grant.

#### LITERATURE CITED

- Al Mutawa, Subhi. 1985. Influence of Shelter Belts. Kuwait University Press, Kuwait.
- Anderson, Susan, Peter L. Warren and Gary P. Nabhan. In press. Vascular plants of the Quitobaquito management area, Organ Pipe Cactus National Monument. Report Submitted to Cooperative National Park Resources Studies Unit, University of Arizona, Tucson Arizona.
- Barclay, John S. 1979. The effects of channelization on riparian vegetation and wildlife in south central Oklahoma. p. 129-138. *In* Strategies for Protection and Management of Floodplain Wetlands and Other Riparian Ecosystems [Callaway Gardens, GA., December 11-13, 1978] USDA Forest Service General Technical Report WO-12, 410 p. USDA Forest Service, Washington D.C.
- Carder, A.C. 1961. Rate of evaporation from free exposure. Canadian Journal of Plant Science 41:1-13.
- Carothers, Steven W., R. Roy Johnson, and Stewart W. Aitchison. 1974. Population structure and social organization of Southwestern riparian birds. American Zoologist 14:97-108.
- Conine, Kathleen H., Bertin W. Anderson, Robert D. Ohmart, and Jeff F. Drake. 1979. Responses of riparian species to agricultural habitat conversions. p. 248-262. *In* Strategies for Protection and Management of Floodplain Wetlands and Other Riparian Ecosystems [Callaway Gardens, GA, December 11-13, 1978] USDA Forest Service General Technical Report WO-12, 410 p. USDA Forest Service, Washington, D.C.
- El Rahman, A.A. Abd and Kitt, Batanouny. 1965. Transpiration of desert plants under different environmental conditions. Journal of Ecology 53(2): 267-273.
- Emslie, Steven D. 1981. Birds and prehistoric agriculture: The New Mexico Pueblos. Human Ecology 9(3): 305-329.
- Hadley, R. and N. King. 1977. The influence of vegetation on the morphology of ephemeral stream channels. U.S. Geological Survey, Denver, CO.
- Johnson, R. Roy. 1979. The Lower Colorado River: A Western System. p. 56-62. *In* Strategies for Protection Wetlands and Other Riparian Systems. [Callaway Gardens, GA, December 11-13, 1978] USDA Forest Service General Technical Report WO-12, 410 p. USDA Forest Service, Washington, D.C.
- Lomas, J. and E. Schlesinger. 1971. The influence of a windbreak on evaporation. Agricultural Meteorology 8:107-115.
- Masse, W. Bruce. 1981. Prehistoric irrigation systems in the Salt River Valley, Arizona. Science 214:408-415.
- Merrick, Laura C. and G.P. Nabhan. 1984. Natural hybridization of the *Cucurbita sororia* group and domesticated *C. mixta* in Southern Sonora, Mexico. Cucurbit Genetics Cooperative Newsletter. 7:74-75.
- Nabhan, Gary P. 1983. Papago fields: Arid lands ethnobotany and agricultural ecology. University of Arizona dissertations.
- Nabhan, Gary P. and Thomas E. Sheridan. 1977. Living fencerows of the Rio San Miguel, Sonora, Mexico: Traditional technology for floodplain Management. Human Ecology. 5:97-111.
- Nabhan, Gary P., Amadeo M. Rea, Karen L. Reichhardt, Eric Mellink and Charles F. Hutchinson. 1982. Papago influences on habitat and biotic diversity: Quitovac oasis ethnoecology. Journal of Ethnobiology. 2(2):124-143.
- Nabhan, Gary P. 1984. Evidence of gene flow between cultivated *Cucurbita mixta* and a field edge population of wild *cucurbita* at Onavas, Sonora. Cucurbit Genetics Cooperative Newsletter. 7:73-74.
- Rea, Amadeo M. 1979. The ecology of Pima fields. Environment Southwest. 484
- Rea, Amadeo M. 1983. Once a river Bird life and habitat changes on the middle Gila. 286 p. University of Arizona Press, Tucson, AZ.
- Reichhardt, Karen L., B. Schladweiler, and J.L. Stelling. 1978. An inventory of riparian habitats along the San Pedro River.
- Reichhardt, Karen, Gary P. Nabhan, Eric Mellink, Charles F. Hutchinson and Amadeo Rea. 1983. Plant and Wildlife Diversity Associated with Native Agriculture of the Sonoran Desert. Final Report to the Consortium for the Study of Man's Relationship with Global Environment. Office of Arid Lands Studies, Tucson, Arizona.

Sheridan, Thomas E. and Gary P. Nabhan. 1979. Traditional technology for floodplain management in Sonora, Mexico. p. 74-82. In Symposium on flood monitoring and management: Proceedings of the Arizona Section, American Water Resources Association. [Tucson, AZ, October 26, 1979] University of Arizona Water Resources Research Center, 96 p., Tucson, AZ.

Yahner, Richard H. 1983b. Small mammals in farmstead shelterbelts: habitat correlates of seasonal abundance and community structure. *Journal of Wildlife Management* 47(1):74-84.

Yahner, Richard H. 1983a Seasonal dynamics, habitat relationships, and management of avifauna in farmstead shelterbelts. *Journal of Wildlife Management*. 47(1) 85-104.



# REM: A Model for Riparian Ecosystem Management in Agricultural Watersheds<sup>1</sup>

Richard Lowrance and Adel Shirmohammadi<sup>2</sup>

---

Abstract.--A model for Riparian Ecosystem Management (REM) is presented. The model is driven by daily hydrologic inputs and is designed to predict water quality changes in riparian ecosystems of agricultural watersheds. Using the principle of the Conservation of Mass, the model predicts water and nutrient inputs from uplands to the riparian ecosystem. Predictions of changes in nutrient levels due to interactions of water with soil, leaf litter, and vegetation are made in four submodels. The next step in this modeling effort is to develop a computer program and to verify the model with available data sets from other watersheds.

---

## INTRODUCTION

Riparian forest ecosystems in the coastal plain are effective filters of nutrients moving in surface and subsurface flow from agricultural fields (Jacobs and Gilliam 1983, Lowrance et al. 1984, Peterjohn and Correll 1984). A model of nutrient filtering in riparian ecosystems is needed in order to properly manage streamside forests as functional parts of agricultural watersheds. In this paper we will present conceptual and mathematical models of riparian ecosystems which might eventually be used to make management decisions for nonpoint source pollution control. The specific example used in this paper is a nitrogen model, but REM is designed to model any of the essential plant nutrients.

This discussion and the model presented here assume a general land use of agricultural lands on better drained upland soils and a forest of mostly native tree and shrub species on poorly drained bottomland soils. The model also assumes that a shallow aquifer is part of the riparian ecosystem and is available for evapotranspiration from the vegetation. This situation exists or has existed in parts of the lower coastal plain, most of the upper coastal plain, and many areas of the southern piedmont.

---

<sup>1</sup>Paper presented at the First North American Riparian Conference, Tucson, Arizona, April 16-18, 1985.

<sup>2</sup>Richard Lowrance is an Ecologist with the Southeast Watershed Research Laboratory, USDA-ARS, and Adel Shirmohammadi is an Assistant Research Agricultural Engineer with the Department of Agricultural Engineering, University of Georgia, Tifton, Georgia, USA.

Nutrient filtering by riparian ecosystems is dependent on nutrient dynamics within streamside forests and on the timing and amount of nutrient transport from agricultural areas. Hydrologic and nutrient transport models of entire watersheds such as the Pesticide Runoff Transport (PRT) model (Crawford and Donigian 1973), the Agricultural Runoff Model (ARM, Donigian and Crawford 1976), and the Agricultural Chemical Transport Model (ACTMO, Frere et al. 1975) are available, but none include explicit models of riparian areas. The model presented here does not treat upland nutrient dynamics and therefore requires that nutrient concentrations in upland runoff be specified as part of the input.

Nutrient dynamics in the riparian ecosystem are controlled by a combination of hydrologic, physical, chemical, and biological processes. The degree of nonpoint pollution control depends on the interaction between the chemical load transported from the uplands and the hydrologic and nutrient cycling processes in the streamside zone.

Water and nutrients enter the riparian ecosystem from upland surface runoff, upland subsurface runoff, and bulk precipitation. Water and nutrients leave the riparian zone via surface runoff and subsurface flow which together constitute streamflow. The important processes affecting surface runoff inputs are infiltration, sediment deposition, and exchange of dissolved nutrients. All of these processes take place at the interface between overland flow and the soil/litter surface. Subsurface flow into the riparian zone generally goes into storage in a shallow alluvial aquifer. Water and nutrients move from the alluvial aquifer

into streamflow or move into the root zone to be available for uptake by vegetation.

### Model Structure

REM is based on dividing the riparian ecosystem into three nutrient pools - a biological pool (VEGETATION) consisting of above and belowground vegetation; a litter pool (LITTER) consisting of both woody and non-woody litter on the forest floor; and a soil pool (SOIL) consisting of organic and inorganic nutrients in the unsaturated soil and in the saturated soil which makes up the shallow alluvial aquifer (Figure 1). These pools of nutrients are initialized based on published data and/or field data and are altered due to inputs and outputs each day. The inputs and outputs are calculated in the nutrient load component of the model (NUTRIENT) which is in turn driven by the hydrology component (HYDROLOGY).

The inputs to the riparian ecosystem are surface runoff from uplands, subsurface runoff from uplands, bulk precipitation, and nitrogen fixation (for REM - nitrogen only). Outputs from the riparian ecosystem are surface and subsurface flow components of total streamflow, harvest of biomass, and denitrification (for REM-nitrogen only). Inputs are modified by the processes taking place in VEGETATION, LITTER, and SOIL to produce outputs.

REM is driven by hydrologic inputs to the riparian ecosystem and by climate as expressed through evapotranspiration. Inputs to the model include the hydrologic parameters needed to calculate surface and subsurface inputs to the riparian ecosystem and the various parameters necessary to simulate fluxes in VEGETATION,

LITTER and SOIL. Most of these parameters are based on empirical data derived from coastal plain riparian ecosystem studies. The HYDROLOGY, NUTRIENT, VEGETATION, LITTER, and SOIL components of the model are described in detail below.

### HYDROLOGY

The HYDROLOGY submodel is used to solve the water balance equation for the riparian ecosystem and to calculate daily surface runoff ( $Q_{usur}$ ) and daily subsurface flow ( $Q_{usub}$ ) inputs from the uplands. The general equation for these calculations is:

$$Q_{usur} + Q_{usub} = Q_{osur} + Q_{osub} + \Delta AS - TF + AET \quad (1)$$

where,  $Q_{osur}$  = surface runoff contribution to total streamflow at the watershed outlet.

$Q_{osub}$  = subsurface runoff contribution to total streamflow at the watershed outlet.

$\Delta AS$  = change in alluvial aquifer storage.

AET = actual evapotranspiration.

TF = throughfall to riparian area.

For a rainday, assuming AET = 0 and that none of  $Q_{usur}$  infiltrates:

$$Q_{usur} = Q_{osur} - (TF - TF_I) \quad (2)$$

and

$$Q_{usub} = Q_{osub} + \Delta AS - TF_I \quad (3)$$

where,  $TF_I$  = throughfall which infiltrates.

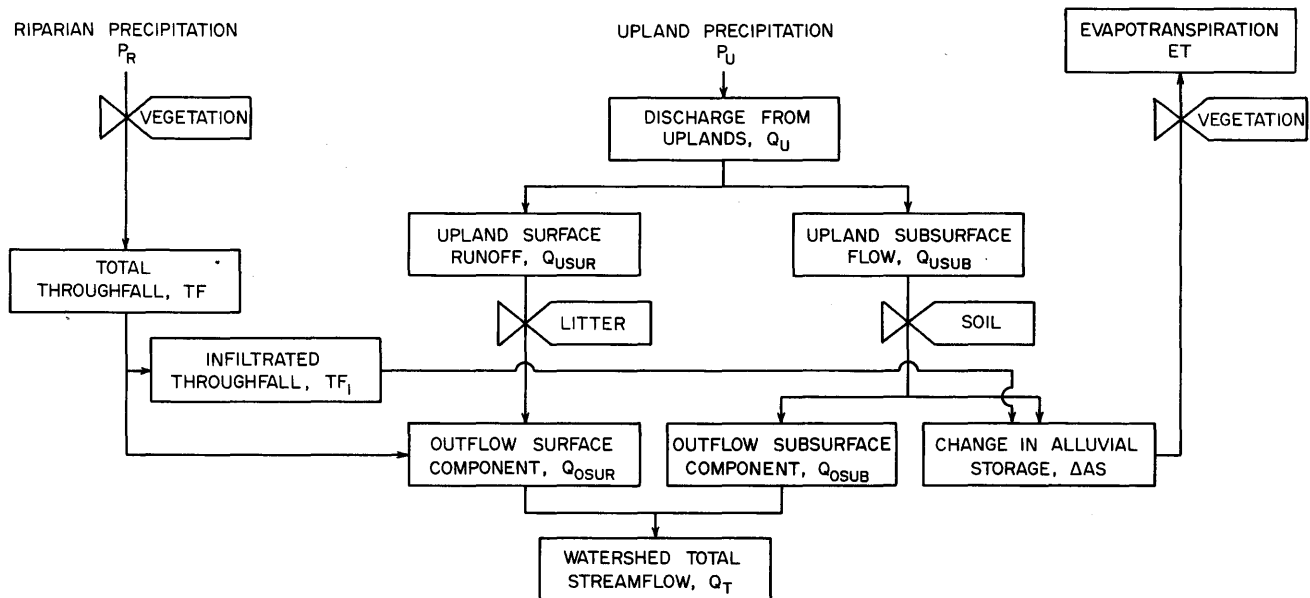

Figure 1.--Flow diagram for the movement of water and associated nutrients in REM.

For a non-rainday where  $Q_{\text{usur}} = 0$ , the upland subsurface flow can be determined as follows:

$$Q_{\text{usub}} = Q_{\text{osub}} + \Delta AS + AET. \quad (4)$$

The input data for HYDROLOGY are daily values of  $Q_{\text{osur}}$ ,  $Q_{\text{osub}}$ ,  $\Delta AS$ , bulk precipitation, and mean daily temperature. The surface and subsurface outputs ( $Q_{\text{osur}}$  and  $Q_{\text{osub}}$ ) are calculated using an approximate method for partitioning daily streamflow data (Shirmohammadi et al. 1984a), and the change in alluvial storage ( $\Delta AS$ ) is calculated from groundwater elevation data using the procedure presented by Shirmohammadi et al. (1984b). Separately measured surface and subsurface components of total streamflow can also be used as input into HYDROLOGY for watersheds where these kinds of data are available.

#### NUTRIENT

The NUTRIENT submodel is used to calculate the daily hydrologic flux of nutrients entering and leaving the riparian ecosystem. The basic equation for outputs is:

$$LOAD = [Q_{\text{osur}} \cdot C_{\text{osur}}] + [Q_{\text{osub}} \cdot C_{\text{osub}}] \quad (5)$$

Expressing equation 5 in terms of upland inputs and riparian hydrologic fluxes, one can define LOAD as follows:

$$LOAD = Q_{\text{usur}} \cdot [(\gamma - 1) \cdot C_{\text{sed}} + (\beta - 1) \cdot C_{\text{sol}}] + (1 - \alpha) \cdot TF \cdot C_{\text{tf}} + Q_{\text{usub}} \cdot C_{\text{usub}} - \Delta AS \cdot C_{\text{usub}} - AET \cdot C_{\text{ss}} \quad (6)$$

where,  $LOAD$  = total streamflow load of nutrient  
 $C_{\text{sed}}$  = concentration of sediment associated nutrient in upland surface runoff,  
 $C_{\text{sol}}$  = concentration of dissolved nutrient in upland surface runoff,  
 $C_{\text{usub}}$  = concentration in upland subsurface runoff,  
 $C_{\text{tf}}$  = concentration in throughfall,  
 $C_{\text{ss}}$  = concentration in unsaturated soil solution,  
 $\alpha$  = fraction of TF which infiltrates,  
 $\beta$  = factor for enrichment or depletion of dissolved concentration by litter,  
 $\gamma$  = factor for enrichment or depletion of sediment associated concentration by soil.

The daily hydrologic data needed in NUTRIENT are passed from HYDROLOGY. The concentration data are given as input to the submodel based on literature values, field data, or other models. Values of the factors  $\alpha$ ,  $\beta$ , and  $\gamma$  are input to NUTRIENT based on infiltration characteristics of soils and literature values of enrichment or depletion of surface runoff by litter or soil,

respectively. Surface runoff moving through riparian forests loses significant quantities of particulate N and P at the water/soil interface (Peterjohn and Correll 1984). The runoff enrichment factors,  $\beta$  and  $\gamma$ , assume that exchange of dissolved nutrients takes place with the litter, and the exchange of sediment-associated nutrients takes place with the soil.

#### SOIL

The SOIL submodel is used to calculate daily changes in the riparian forest soil nutrient pool. The soil nutrient pool includes the nutrients in alluvial storage. The major processes in the SOIL submodel, decomposition and uptake, are driven by the relationship between daily actual evapotranspiration and the maximum daily AET for the forest. The SOIL submodel solves the equation:

$$\Delta SOIL = (MAXDEC - MAXUPTK) \cdot \left( \frac{AET}{MAXAET} \right) - MAXDEN \cdot \left( \frac{F_n + F_m + F_t}{3} \right) + (1 - \gamma) Q_{\text{usur}} \cdot C_{\text{sed}} + \Delta AS \cdot C_{\text{usub}} \quad (7)$$

where,  $MAXDEC$  = maximum daily litter decomposition rate,  
 $MAXUPTK$  = maximum daily uptake rate by vegetation,  
 $MAXAET$  = maximum daily AET for riparian ecosystem,  
 $MAXDEN$  = maximum daily denitrification rate.  
 $F_n, F_m, F_t$  = factors related to soil  $NO_3-N$ , soil moisture, and soil temperature, respectively. These vary from 0 to 1.

For nutrients other than nitrogen, the output due to denitrification is omitted.

The maximum rates of decomposition, uptake, and denitrification are determined from literature values or field data. The maximum daily AET rate is calculated from long-term (10 year) water balance computations in order to find the maximum actual evapotranspiration from a site.

The factors used to control maximum denitrification are based on empirical data of the relationships between denitrification rates and soil moisture, soil nitrate, and soil temperature. The denitrification factors assume that the maximum activity takes place in saturated soil at a soil temperature of 35°C. Growing plants and denitrifying bacteria compete for the available  $NO_3-N$  in the soil. Based on an extensive study of environmental factors affecting denitrification in bottomland soils (Hendrickson 1981),  $F_n$  and  $F_m$  are maximum in May. The nitrogen factor is minimal in July, and the moisture factor is minimal in October. The temperature factor peaks during August.

## LITTER

The LITTER submodel calculates daily changes in the riparian ecosystem litter nutrient pool. The LITTER submodel solves the equation:

$$\Delta \text{LITTER} = \text{LITFALL} + [(1-\beta) \cdot Q_{\text{usur}} \cdot C_{\text{usur}}] - \text{MAXDEC} \cdot \left( \frac{\text{AET}}{\text{MAXAET}} \right) \quad (8)$$

where, LITFALL = litterfall based on Julian date.

Litterfall includes both woody and nonwoody litter and is based on literature values or field data. Other parameters in equation 8 are defined in previous sections.

## VEGETATION

The VEGETATION submodel calculates daily changes in the living vegetation nutrient pool using the equation:

$$\Delta \text{VEGETATION} = \text{MAXUPTK} \cdot \left( \frac{\text{AET}}{\text{MAXAET}} \right) - \text{LITFALL} - \text{HARVEST} \quad (9)$$

where, HARVEST = daily removal of woody material.

Harvest data are based on field data and allow the effects of forest clearing to be simulated. Forest clearing affects the values used for MAXUPTK since this is based on mass/area and is decreased when fewer trees remain per unit area. Tree harvest also adds a pulse of litterfall to the forest floor although future litterfall is decreased.

## DAILY BALANCE

REM calculates the final riparian nutrient pool each day from the previous day's level and the changes calculated in SOIL, LITTER, and VEGETATION submodels:

$$\text{FRIPNUT} = \text{IRIPNUT} + \Delta \text{SOIL} + \Delta \text{LITTER} + \Delta \text{VEGETATION} \quad (10)$$

where, FRIPNUT = nutrient pool for day (i)  
IRIPNUT = nutrient pool for day (i-1).

Model output on a daily basis includes SOIL, LITTER, VEGETATION, FRIPNUT, and LOAD.

## POTENTIAL USES

The Riparian Ecosystem Management model, once it is refined and functional, will be useful either by itself or combined with existing models of nutrient transport from agricultural fields such as CREAMS (Knisel 1980). Coupled with a field-scale model of nutrient transport, REM would process upland inputs without relying on partitioning of total streamflow in order to calculate  $Q_{\text{usur}}$  and  $Q_{\text{usub}}$ .

At this point in its development, the model is based on a body of empirical evidence about the function of coastal plain riparian ecosystems. REM incorporates hydrologic and nutrient cycling realism through a large quantity of empirical factors requiring estimation by the user. Despite this need for many empirical relationships, REM represents an attempt at a simple usable management model which avoids the difficulties of simulating the effects of individual storm events on riparian ecosystem processes.

## LITERATURE CITED

- Crawford, N. H., and A. S. Donigian, Jr. 1973. Pesticide transport and runoff model for agricultural lands. EPA-660/274-013. Office of Res. and Development, U.S. Environmental Protection Agency, Washington, D.C. 211 p.
- Donigian, A. S., Jr., and N. H. Crawford. 1976. Modeling pesticides and nutrients on agricultural lands. Environmental Protection Technology Series, EPA-600/2-76-043. Office of Res. and Development, U.S. Environmental Protection Agency, Washington, D.C. 311 p.
- Frere, M. H., C. A. Onstad, and H. N. Holtan. 1975. ACTMO, an Agricultural Chemical Transport Model. U.S. Department of Agriculture, Agricultural Research Service, ARS-H-3. U.S. Govt. Printing Office, Washington, D.C. 54 p.
- Hendrickson, O. Q., Jr., 1981. Flux of nitrogen and carbon gases in bottomland soils of an agricultural watershed. Athens, GA, University of Georgia, 210 p. Dissertation.
- Jacobs, T. C. and J. W. Gilliam. 1983. Nitrate loss from agricultural drainage waters: implications for nonpoint source control. Water Resources Research Institute, University of North Carolina, Raleigh, NC. Report No. 209.
- Knisel, W. J. (editor) 1980. CREAMS: A Model of Chemicals, Runoff, and Erosion from Agricultural Management Systems. U.S. Dept. of Agric., Agric. Res. Serv.
- Lowrance, R., R. Todd, J. Fail, Jr., O. Hendrickson, Jr., R. Leonard, and L. Asmussen. 1984. Riparian forests as nutrient filters in agricultural watersheds. BioScience 34:374-377.
- Peterjohn, W. T. and D. L. Correll. 1984. Nutrient dynamics in an agricultural watershed: observations on the role of a riparian forest. Ecology 65:1466-1475.
- Shirmohammadi, A., W. G. Knisel, and J. M. Sheridan. 1984a. An approximate method for partitioning daily streamflow data. Journal of Hydrology 74(3/4):335-354.
- Shirmohammadi, A., J. M. Sheridan, and L. E. Asmussen. 1984b. Hydrology of alluvial stream channels in southern coastal plain watersheds. ASAE paper No. 84-2502, presented at the 1984 Winter ASAE Meeting, New Orleans, Louisiana, 23 p.

# Riparian Vegetation Reduces Stream Bank and Row Crop Flood Damages<sup>1</sup>

Donald Roseboom and Kenneth Russell<sup>2</sup>

---

Abstract.--Large alluvial stream valleys in the prairies of western Illinois have been channelized to increase the size of row crop fields. Fish surveys at thirteen sites in the 61,760 acre watershed documented the elimination of large game fish in old channelized stream segments when upstream segments contained smallmouth bass up to 2.7 lbs. Channelized stream banks contributed much of the sediment, which eliminated instream habitat.

---

## INTRODUCTION

The Soil Conservation Service has designated 33 Illinois counties in the Mississippi and Illinois River basins of western Illinois as critical sediment producing areas (Crews, 1983). Western Illinois streams have highest instream sediment yields in the state (Bonini et al., 1983). Non-point pollution is generally regarded as the most common cause of stream degradation in Midwestern streams (Judy et al., 1984).

From 1980 to 1983, the Illinois Department of Energy and Natural Resources funded a study by the Illinois State Water Survey to determine the effects of land use on water quality in a 97.5 square mile watershed in western Illinois. By determining the extent of different land uses in 16 large subwatersheds during two years of stream sampling, the influences of agriculture, stripmining, urban activities, and stream modifications were assessed in watershed streams.

## GEOGRAPHIC AREA

Court Creek flows east along the southern boundary of the watershed from Galesburg, IL to the Spoon River at Dahinda, IL. Three major tributaries (Middle Creek, North Creek, and Sugar Creek) drain 65 percent of the watershed from the north. Ten land uses of agriculture, stripmining,

and residential land management types were planimeted from ASCS aerial photographs for the entire watershed. Agricultural land uses were row crop (corn and soybean), pasture, and wooded pasture. Row crops were the largest single land use in the watershed (49 percent of the area).

The topography and soil types in the watershed were determined during the Wisconsin Glacier Age. Glacier deposits not only formed the flat prairie of western Illinois, but torrential runoff from melting glaciers formed very large stream valleys with extremely steep bluffs. Present day streams meandered down the wide floodplains formed by glacier runoff. Fehrenbacher et al. (1977) described the upland prairie and floodplain landforms of waterways in western Illinois. Soil types have developed as dark upland prairie soil, lighter timber soil along the bluffs, and alluvium from soil deposition in the old glacier valleys. Row crop acreages are confined to the relatively flat upland prairie and the floodplain. Pastures and wooded pastures are found on bluffs bordering the floodplain because the steep slopes and infertile soils preclude other agricultural uses. Stripmined land is also very steep and is almost entirely pasture.

## METHODOLOGY

Sixteen stream sampling stations were established on Court Creek and its tributaries. Subwatersheds are the watershed areas between sampling stations. The extent of each subwatershed area determined from U.S. Geological Survey topographical maps developed in 1978. Each quarter section of land use was placed in a subwatershed on the basis of topographic maps. The extent of land uses were measured for each quarter section of watershed from 5 sets of aerial photographs taken between 1940 and 1979. By this method the extent of agriculture, stripmining, residential housing, and stream length reduction was determined in each subwatershed.

---

<sup>1</sup>Paper presented at Riparian Ecosystems and their Management. University of Arizona, Tucson, April 16-17, 1985.

<sup>2</sup>Donald Roseboom is Associate Professional Scientist, Illinois State Water Survey, Peoria, IL. Kenneth Russell is District Fishery Biologist, Illinois Department of Conservation, Galesburg, IL.

Stream flow gages were established at nine of the 16 subwatershed sampling stations. Flows at ungaged sampling stations were calculated on the basis of watershed area. A continuous stage recorder was placed at the C2 sampling station. Flow-duration curves of staff gages were adjusted to the flow-duration curve of the C2 continuous stage recorder. Stream samples were obtained with a USGS depth-integrating DH-59 sampler.

Annual stream loadings were calculated by means of a flow-duration curve and a sediment or nutrient discharge curve. Stream loadings for individual storms were determined by sampling each event during the rise and fall of flood waters. Each stream sample represented a stream flow and a sampling time period. Sediment and nutrient loadings (lbs.) per sampling period (min.) were determined as the product of stream flow (cfs), sample concentration (mg/L), time period (min.) and a factor of 0.003747. The storm loadings were the sum of the sampling period loadings.

Fish survey sites were established on stream segments representing the upper and lower sectors of the principal streams in the watershed. Illinois Department of Conservation personnel performed the fish surveys and identified the collected fishes. Fish were collected with a rotenone-potassium permanganate technique with a blocking net at the lower end of the site. Each site contained a pool and riffle. Stream habitat evaluations for in-stream habitat, water depth, stream bed materials, and riparian vegetation were made by experienced Illinois Department of Conservation personnel.

## RESULTS

The C2 sampling station represented the combined effects of all land uses in the entire watershed (table 1). At the C2 station, sediment, total ammonia, and total phosphorus were the most pronounced water quality effects. The bulk of the row crops were in the flat upland prairie surrounding the headwaters of streams as in the M3 subwatershed. The sediment and nutrient yields of upland prairie subwatersheds are compared with yields from one floodplain subwatershed and the total watershed in Table 1. The three upland prairie subwatersheds of M3, S5, and C12 represent, respectively, the contribution of agriculture, stripmining, and

residential land uses to the major water quality problems at C2.

The M3 subwatershed is 71 percent row crop (3093 of 4320 acres) and had the highest annual sediment and nutrient yield of the three upland prairie subwatersheds. However, the agricultural subwatershed between the M1 and M3 sampling stations is only 40 percent row crop (834 of 2080 acres) but had much greater stream sediment and nutrient yields. The M1 subwatershed had annual sediment and nutrient yields similar to the net annual yields for the entire watershed at sampling station C2.

During April of 1983 the amount of sediment and nutrients transported during a single storm (storm loadings) were determined. The M1 subwatershed contributed 74, 74, and 66 percent of the sediment, phosphorus, and ammonia loadings, even though it represents only 33 percent of the combined M1 and M3 subwatersheds. The peak stream flow at M1 was 320 cfs from 2.4 inches of rain while the peak flow at M3 was 76 cfs from 2.1 inches of rain.

An analyses of the M1 and M3 subwatersheds revealed 58 percent of the M1 subwatershed and only 25 percent of the M3 subwatershed had steep slopes (>15 percent). Bluffs along the floodplain become even steeper in lower segments of Middle Creek. This steep topography increases the rate of storm water runoff as indicated by greater peak storm flows at M1. A comparison of aerial photographs between 1940 and 1979 found a 7 percent stream length reduction in the M1 subwatershed. Channelization further increases the rate of storm water runoff. Even more importantly, 25 percent of M1 subwatershed lays in the floodplain below the steep bluffs. Since row crop fields are the dominant land use in the relatively flat floodplain, this cultivated land occurs downstream of areas in which storm water runoff reaches high velocity. The primary complaint of land owners in floodplain subwatersheds is damage to row crop fields from high velocity stream flows, not submergence of crops. Channelization efforts in the floodplain during the 1980's were attempts to divert high velocity stream flows from row crop fields. Either the stream is straightened (thus increasing stream velocity) or diverted into the bluff (eroding large earthen cliffs).

Table 1. Annual stream yield on a per acre basis.

Landform type	Upland prairie	Upland prairie	Upland prairie	Floodplain alluvium	Total watershed at C2
Land use	Residential	Mining	Agriculture	Agriculture	
Sediment tons/ac/yr	0.7	1.0	1.7	9.2	7.5
Ammonia lbs/ac/yr	1.8	1.4	2.5	4.6	3.7
Phosphorus lbs/ac/yr	2.9	2.0	7.4	14.0	14.2

Downstream floodplain subwatersheds had even greater annual sediment yields of 52.2, 26.8, 23.4, 46.5, and 21.0 tons/acre/yr. On North Creek, the lower 25 percent of the watershed contributed 50 percent of the annual sediment yields. Stream nutrient yields for floodplain subwatersheds are closely correlated with sediment yields. As in Middle Creek, these floodplain subwatersheds are bordered by very steep bluffs, which have high rates of surface water runoff.

Stream lengths in downstream floodplain subwatersheds have been reduced by an average of 15 percent since 1940. Stream reduction as great as 25 percent were determined from 1940 and 1979 aerial photographs. The broad floodplain of Court Creek had similar stream length reductions. Stream reconnaissance of floodplain subwatersheds found major bank erosion sites occurring at the sites of former stream meanders in the floodplain, especially sites bordering row crop fields.

Bank erosion measurements were begun during the second year of sampling when analysis of the 1981 annual sediment yields found large increases of sediment yield from the floodplain subwatersheds. In the eroding banks, Soil Conservation Service (SCS) personnel identified a sandy overburden of recent origin, a well developed soil layer developed over thousands of years, and a sandy glacial outwash dating from the glacial ages. A 48 inch steel pin was driven into each bank layer following the method described by J.M. Hooke (1979). Six foot wooden stakes were driven vertically into the stream bed and bank to mark the pin positions. The location of each set of three pins was marked by a wooden stake placed 15 feet from the edge of the bank. Bank erosion measurements were made with a steel surveyors tape after each storm. The weight of the eroded bank was the product of the length of the section, the height of the bank, the depth of erosion into the bank, and a unit weight of 90 lbs/cu. ft. SCS personnel from the Knox County soil survey estimated this unit weight during the inspection of the eroding banks.

In July of 1982, flood waters eroded as much as 1150 tons of soil from a single bank erosion site during one storm. These storms also caused the extensive uprooting of very large trees, which hung up on sand bars and diverted much of the stream flow into stream banks and across row crop fields. In an attempt to correlate the contribution of eroding stream banks to the sediment budget of large streams, the amount of bank erosion at seven sites was measured during the next three storms. The amount of bank soil eroded from all seven sites during the three storms is shown in column 4 of Table 2. Chemical analysis of bank soils for total ammonia and total phosphorus permitted the determination of the amounts of ammonia and phosphorus entering the stream with bank soil.

Storm yields for the three storm events are also given in Table 2. Bank erosion from just seven bank erosion sites represents a significant proportion of the sediment, phosphorus, and ammonia leaving the entire watershed at C2. Given the extent of bank instability found during stream sur-

Table 2. Percentage of storm yield eroded from seven bank erosion sites

Type of yield	Storm date	Storm yield	Amount eroded from seven bank sites <sup>1</sup>	Percent of storm yield from eroded banks
Sediment (tons)	12/2/82	13387	1391	10.4
	12/24/82	13206	639	4.8
	4/1/83	33293	2551	7.7
T. Ammonia (lbs)	12/2/82	4569	166.9	3.7
	12/24/82	3524	76.7	2.2
	4/1/83	8470	306.1	3.6
T. Phosphorus (lbs)	12/2/82	37858	7511	19.8
	12/24/82	29311	3451	11.8
	4/1/83	53381	13775	25.8

<sup>1</sup> Weights are calculated from bank soils with a unit weight of 90 lbs. per cubic foot with average total ammonia and total phosphorus concentrations of 60 mg/kg and 2700 mg/kg respectively.

veys of Court Creek and its three tributaries, these seven sites are not estimated to contribute more than 10 percent of the total bank erosion occurring during major storms.

Fish surveys revealed instream habitat degradation in channelized floodplain stream segments, even though channelization occurred at least 20 years earlier. The habitat degradation and its effects on fish populations are illustrated by two fish survey sites on Court Creek - C3 and C6 (table 3). The C3 site was located below 72 square miles of watershed while the C6 site had a watershed area of 35 square miles. Both water depth and instream habitat at C3 were severely reduced by the deposition of fine sands. Stream banks had very little woody riparian vegetation and large bank erosion sites were present upstream. Approximately 20 percent of bank soils at major bank erosion sites were fine sand. Much of the sand was located in the lowest layer of bank soil.

The C6 fish survey site was characterized by deep pools with instream cover of snags and exposed tree roots. High gradient riffles provided coarse gravel and large rock rubble. Large mature trees increased bank stability and provided shade. Stream fish populations reflected the habitat differences between C3 and C6. The standing crop of fish at C6 was 303 pounds per acre while the C3 site had only 100 pounds per acre even though both sites contained over 2600 fish. At C3 forage species represented 95 percent of the crop by number and 55 percent of the crop by weight. Bluntnose minnows and sand shiners were the most abundant species. Game fish comprised only 4 percent of the C3 crop by weight.

At the C6 site, forage species comprised 88 percent of the crop by number but only 10 percent by weight. Game fish, mainly smallmouth bass, comprised 22 percent of the crop by weight. Eighty

Table 3. Species and number of fishes found in unstable channelized stream site C3 and the stable site C6.

Species	C3	C6
Largemouth Bass	22	10
Smallmouth Bass	8	87
Bluegill	29	15
Green Sunfish	19	11
Channel Catfish	11	9
Yellow Bullhead	12	38
Stonecat	7	26
River Carpsucker		14
Quillback	33	40
White Sucker		2
Golden Redhorse	9	76
Carp		3
Stoneroller	107	37
Hornyhead Chub	35	24
Emerald Shiner	116	
Striped Shiner	9	56
Bigmouth Shiner	134	3
Red Shiner	360	93
Sand Shiner	769	59
Suckermouth Minnow	3	
Bluntnose Minnow	928	1963
Fathead Minnow	3	
Creek Chub	23	31
Johnny Darter	7	6
Orangethroated Darter		3
Logperch		1
No. of Fish	2646	2607
No. of Species	22	23

seven smallmouth bass were found with weights up to 2.7 lbs. Pool depth and instream habitat were the most important habitat differences found between the C6 and C3 survey sites. The major bank erosion sites upstream of the C3 site contributed tons of sand to the stream during flooding. The deposition of this sand is the major cause of stream degradation in the watershed.

#### DISCUSSION

Floodplains in Knox County have served as sediment traps for upstream erosion for thousands of years; indeed floodplain soils are characterized as alluvium. Forests in western Illinois were confined to the floodplain bluffs and large valleys formed by glacial melting. The major land use changes in these floodplain areas has been the removal of forests and the channelization of streams to maximize row crop fields and increase the rate of storm water runoff. The Court Creek study suggests this land management practice has been too extensive.

A comparison of 1940 and 1979 aerial photographs of C2 subwatershed revealed the complete erosion of a small field at bank erosion site III. An average of 2000 tons of soil was eroded every year from 600 feet of bank. The soil deposited over thousands of years was replaced by sand, gravel,

and scrub timber. Except for the constant filling of eroded banks by the local land owners, such field damage would be more apparent on aerial photographs.

Now the major reason for channelization is to divert floodwaters from eroding into floodplain fields. Erosion of floodplain fields also occurs as scour in areas away from the stream bank. Channelization is often practiced without legal authorization as the only method available for the local land owner to limit flood damages to fields. Aerial photography and bank erosion measurements suggest channelization is a short term solution, which results in long term damages to streams and surrounding row crop fields.

Individual land owners are attempting to stabilize stream banks, but are having limited success. Between areas of extensive bank erosion, certain channelized stream segments demonstrated remarkable stability. These stream segments were characterized by a well developed stream border of woody vegetation, which reduce stream flow velocity and prevent bank erosion. These green belts of trees act on high velocity water in the same manner that wind breaks of trees act on high velocity winds. They reduce erosion by decreasing the velocity of the flood waters at the surface of bank soils. They reduce the effects of upstream erosion since sedimentation occurs among the trees and forms a natural levee. Sand is deposited along the banks and not as sand bars in floodplain fields.

#### LITERATURE CITED

- Bonini, A.P., N.G. Bhowmik, R.L. Allgire, and D.K. Davie. 1983. Statewide instream sediment monitoring program for Illinois. SWS Contract Report 318A, 45 pp. IL. St. Water Sur. Champaign, IL.
- Crews, W. 1983. Erosion in the upper Mississippi River system: an analysis of the problem. 17 pp. Upper Mississippi River Basin Assoc. St. Paul, MN.
- Fehrenbacher, J.B., I.J. Jansen, B.W. Ray, J.D. Alexander, and T.S. Harris. 1977. Soil associations of Knox County, Illinois. Spec. Publ. 46. 27 pp. University of IL, College of Agriculture, Urbana, IL.
- Hooke, J.M. 1979. An analysis of the processes of river bank erosion. Jour. Hydrol. 42:39-62.
- Judy R.D., P.N. Seeley, T.M. Murray, S.C. Svirsky, M.R. Whitworth, and L.S. Ischinger. 1984. 1982 national fisheries survey vol. I technical report: initial findings. 140 pp. FWS/OBS-84/06. Fish and Wildlife Service. Washington, D.C.
- Roseboom, D.P., R.L. Evans, J.E. Erickson, and L.G. Brooks. 1982. An inventory of Court Creek watershed characteristics that may relate to water quality in the watershed. Doc. No. 83/23-A. 95 pp. IL. St. Water Survey. Peoria, IL.



# The Pecan Orchard as a Riparian Ecosystem<sup>1</sup>

Kenneth J. Kingsley<sup>2</sup>

---

Abstract.--The world's largest irrigated pecan orchard is located 20 miles south of Tucson, Arizona, in the Sahuarita-Green Valley area. The mature orchard is a dense woodland of tall deciduous trees, with abundant weeds as understory and surface water generally available. Native animals have invaded the orchard and adapted to it.

---

## INTRODUCTION

The decline of native riparian habitat in the southwestern U.S. has been well documented and much lamented. The Santa Cruz River runs northward from Mexico, up through southern Arizona to join the Gila River just south of Phoenix. Johnson and Carothers (1982) summarized the transformation of the riparian habitat along the Santa Cruz River. Irrigated agriculture has flourished in the Santa Cruz valley for hundreds of years. Native American farmers were replaced by Spanish who were in turn replaced by Anglos. All practiced the same basic flood irrigation techniques and grew many of the same crops. But the scale of agriculture changed over time. In the 1950's, the Sahuarita-Green Valley area 20 miles south of Tucson had more than 6000 acres of cotton and small grains. A few mesquite trees remained in places along the river banks, but essentially the native riparian habitat was gone, and with it the native animals that require riparian habitat. Agricultural development may have significant adverse impact on wildlife communities when riparian habitat is converted to agricultural uses (Connie et al. 1978).

In 1964, the Farmers' Investment Company (FICO) began conversion of their cotton and small grains acreage to pecans (Walden 1970). Presently about 4500 acres are devoted to pecans, making this the world's largest irrigated pecan orchard. Wells et al. (1979) have published apparently the only paper on use of western orchards by native wildlife. Apparently no published reports on wildlife uses of pecan orchards exist, with the exception of one paper (Couch 1981) on wildlife pest control in pecans.

The pecan tree is a native of the southern United States and northern Mexico. Wild pecans are found from west central Texas to western Alabama in the east and extend up the Mississippi River and its tributaries into southern Illinois. In its native range the pecan tree is largely confined to bottomlands and floodplains bordering rivers and streams. In prime habitat, the wild pecan is so successful as a competitor that virtually all other significant tree species are eliminated, leaving almost pure stands of pecans (Wolstenholme 1979). Pecans are not native in Arizona, but were introduced in about 1920. By 1978 there were over 12,000 commercial acres of pecan trees in Arizona, mostly in Pima, Pinal and Maricopa counties (Miekle and True 1981). All pecan culture in Arizona depends upon irrigation; the climate is much too dry to support the trees without the growers providing a large amount of water. Drip or trickle irrigation has been used successfully on some of the smaller plantings of pecans (Bach and Kuykendall 1971), but the largest orchards use flood irrigation, on a two-week schedule.

Over the years, the pecan trees on the FICO farm have grown and appear to be maturing into a biotic community that is very similar to the native riparian community in some ways, yet is also different from it. The information presented here was gathered incidental to a study of pest mosquitoes that breed in the orchard.

## DESCRIPTION OF THE AREA

The orchard presently consists of approximately 4500 acres of pecan trees, divided by roads and canals into fields ranging in size from 5.3 to 143 acres. The fields are more or less contiguous along the east side of the Santa Cruz River for approximately 10 miles. The southern half of the farm has had the land on the west side of the river developed as the Green Valley retirement community. Green Valley presently is a thriving retirement community of approximately 11,000 residents. It is rapidly growing, with projections for a population of approximately 100,000 residents in the year 2000. Most of the development will be

---

<sup>1</sup>Paper presented at the Interagency North American Riparian Conference on Riparian Ecosystems and their Management. Univ. of Arizona, Tucson, April 16-18, 1985.

<sup>2</sup>Graduate student, Department of Entomology, Univ. of Arizona, Tucson.

on land that is presently in pecans. The development grew up on the west side of the orchard, paralleling the orchard and the river. Between the orchard and the houses, in the area designated as floodplain, golf courses and recreation centers were created. The development plans call for more golf courses in some of the floodplain, with about 1800 acres remaining in pecans. The northern half of the farm has the land on both sides of the river in pecans, where it is about 1.5 miles wide. Adjacent to the orchard, at widely scattered locations are individual houses, the communities of Continental and Sahuarita, and a trailer park.

Irrigation water is pumped from wells and distributed about the farm in a system of concrete-lined ditches. At each field, when irrigation time arrives, the ditch at the head of the field is filled with water, and water siphoned from the ditch into the areas between tree rows, called borders. The borders are 30 feet wide, and may be two or three hundred yards long. Borders are filled with water to a depth of six inches to a foot. Each day sections of several fields are irrigated, with a complete rotation around the farm approximately every two weeks. During the drier parts of the year, water percolates through the soil rather quickly, but the soils on approximately 20 percent of the farm are high enough in clay content that puddles may last for several days to a week. During the rainy season in July and August, parts of some fields may remain wet continuously, creating a swamp that may last for several weeks.

The trees were originally planted at a density of 96 trees per acre on 2,500 acres, 80 trees per acre on 1,000 acres, and 48 trees per acre on 2,500 acres. Thinning has occurred on most of the land, so that present density does not exceed 48 trees per acre, and in the fields with the largest trees, density is now 24 trees/acre. Eventually a density of 12 trees/acre is anticipated. With the exception of trees planted to replace the very few that have died, all trees in a given field are the same age, and very similar in size. As a general management policy, no tillage is done in the fields. Dense weeds grow in the borders. The farmers attempt to keep the weeds down by mowing, but stop during the rainy season because the soil is too muddy. The dominant weed species is barnyard grass, Echinochloa cruzgalli, which can grow to more than six feet tall and is a major producer of seeds that are potentially valuable as food for wildlife (Martin et al. 1951). Shrubs are not present, and would not be tolerated. Around the edges of many of the fields there are slash piles, where cuttings from the trees are dumped.

#### ANIMAL USE OF THE ORCHARD

##### Invertebrates

The most abundant invertebrates appear to be mosquitoes and aphids. Two species of floodwater mosquitoes, Aedes vexans and Psorophora columbiae,

breed prodigiously in the orchard and are a serious pest for farm workers and residents of the area. There is also a large dragonfly population, with at least nine species of dragonflies found in the orchard. They are probably eating the adult mosquitoes. The amount of permanent water suitable as breeding habitat for dragonflies seems insufficient in the area to support the dragonfly population. The larvae require long-lasting water (Corbet 1980), and the only water I have found in the vicinity that seems suitable is in cowponds and golf course water hazards, which are heavily stocked with fish that might eat or compete with dragonfly larvae. I have found a few larvae in some irrigation ditches, and seen adults ovipositing in ditches and flooded borders, but I have not found water in the orchard that would last long enough for dragonfly larvae to grow to maturity. The abundant adults may be immigrants or transients. Damselflies of several species are also abundant. Several aquatic insects are common, including the giant water scavenger beetle Hydrophilus triangularis and several species of notonectidae. These insects rapidly colonize newly flooded borders and attempt to reproduce, but usually the water is gone before the insects mature. I have also found crustaceans, including seed shrimp, clam shrimp, and fairy shrimp occurring in the flooded borders. A systematic survey of the invertebrates of the pecan orchard would probably turn up many more taxa that are characteristically found in our native riparian habitats.

##### Vertebrates

The vertebrate fauna is more conspicuous and easier to note with casual observation than the invertebrates. Birds are the only vertebrates for which I have kept consistent records, the other vertebrates being observed incidentally during my other studies. The only species of fish found in the orchard is the mosquito fish, Gambusia affinis. The fish were originally planted in stockponds adjacent to the orchard, one of which is filled by a ditch bringing water from one of the irrigation canals. Occasionally some fish swim upstream and get out into the orchard when irrigation is occurring. They live for a few days and then either have to find a way back home or die when the water dries up.

##### Amphibians

Several species of toads are abundant in the orchard. The large Colorado River Toad, Bufo alvarius, breeds in the ditches and also in some of the waterlogged borders. Red spotted toads, Bufo punctatus, and Great Plains toads, Bufo cognatus, are abundant and breed successfully in some of the borders, although most of the tadpoles are stranded when the irrigation water seeps into the soil. Early in irrigation season, most of the amphibians' reproductive effort is wasted, since water does not remain long enough for tadpoles to mature. Once the summer rains have begun, many puddles in the orchard originally created by

irrigation water are replenished by rain water and last long enough for successful toad reproduction. Couch's spadefoot toads, Scaphiopus couchi, breed very successfully in parts of the orchard during the summer rainy season.

#### Reptiles

Reptiles are much less common in the orchard than amphibians. Apparently the ground-living reptiles can not survive well when the land is flooded so often. I have seen a few tree lizards, Urosaurus ornatus, and desert spiny lizards, Sceloporus magister, but lizards appear to be, at least to casual observation, rather scarce. Snakes also are uncommon. In three summers, I have not seen a rattlesnake in the orchard, although farm workers have told me that they have seen rattlesnakes. I have seen two gopher snakes, Pituophis melanoleucus, and one garter snake, Thamnophis sp. The gopher snakes were both outside the flooded area, along ditchbanks. The garter snake was in the area that is flooded, and appeared to be feeding on toadlets.

#### Birds

Birds are abundant in the orchard. A list of the birds observed in the orchard is presented in Table 1.

I would like to briefly mention a few of the more interesting species, and point out what they may be doing in the orchard. Hawks are abundant: Red-tailed Hawks are present all year, apparently feeding on rock squirrels which are extremely abundant. I have observed no Red-tailed Hawk nests in the orchard; good nest sites may be a limiting factor for the population. The farmers are considering erecting artificial nest platforms in the hope of increasing their density, in an attempt to decrease the squirrel population. Other hawks are seasonally common to abundant. Most are apparently migrating through the area and discover the abundant squirrels, so stay for a few days or weeks.

Several species of birds characteristically found in native riparian habitats have settled in the orchard. Yellow-billed Cuckoos, which are scarce and declining in native habitats (Gaines 1977) appear to be abundant in the orchard. I have not attempted a systematic count, but that there is approximately one nesting pair per ten acres. This is approximately the same density observed by R. R. Johnson (personal communication) in mature cottonwood forests on the Salt and Verde Rivers, Arizona. Black Phoebes, although uncommon, are probably nesting. Lucy's Warbler and Yellow Warblers are abundant nesting birds in the orchard, as they are in native riparian woodland (Phillips et al. 1964). Blue Grosbeaks are common nesting birds here. Lazuli Buntings are present but uncommon, and they are probably summer visitors rather than nesters. Lesser Goldfinches are abundant throughout the summer. Song Sparrows,

which are characteristically found in reed-sedge-brush types along major permanent rivers (Phillips et al. 1964) are present and singing all summer long in the weeds around the orchards and in slash piles, but their breeding status is unknown. Albert's Towhees are also present in and around the slash piles. Red-winged Blackbirds are abundant and appear to follow the irrigators, glean insects flooded out of the soil by the irrigation water. I have found no nests of these birds, but they are abundant throughout the summer, probably only as transient foragers. Both Hooded and Northern Orioles, common birds in native riparian woodlands (Phillips et al. 1964) are not common in the orchard and their nesting status is not known.

Some birds that might be expected in riparian habitat are apparently absent in the orchard. The Cardinal and Bell's Vireo are apparently not present. They typically live in brushy areas along streams (Phillips et al. 1964), and in the orchards there is no shrub midstory of vegetation. The vegetation profile in the orchard is limited to an understory of weeds, sometimes very tall and dense, although the farmers try to keep the weeds down, and a tall canopy of pecan trees. This limits the diversity of foliage layers for foraging and nesting, and would effectively eliminate species that prefer the shrub midstory that is characteristic of some native riparian woodland. Slash piles around the orchard may be suitable for some species of midstory-frequenting birds, such as Abert's Towhee, and not others. The slash piles are not covered by a canopy of trees, and this may reduce their usefulness to some species. Hole-nesting birds are rare. Woodpeckers apparently do not make holes in the pecan trees, although 3 species of woodpeckers are occasionally seen in the orchard. Tree holes caused by rot setting in where branches have broken off apparently do not occur because the trees are well care for, and broken limbs treated to prevent fungus infection. A native fungus, Cytospora sp., which invades broken limbs has created problems for the growers. It is characteristically found in cottonwood trees. Careful treatment of the trees has kept infection with the fungus to a minimum. Snag nesting birds are also absent, because dead trees are removed and replaced by the farmers.

#### Mammals

A number of species of mammals live in or use the orchard. I have made no attempt to investigate the mammal fauna, except very casually. Because most species are nocturnal, casual observation has been insufficient to get any but the most superficial picture of the fauna. Bats are rather abundant and appear to be of several species. They are probably feeding on adult mosquitoes (Hinman 1934). Coyotes, Canis latrans, are very common, as are javelina, Pecari tajacu. Both of these probably eat some of pecans. Raccoon, Procyon lotor, tracks and skunk tracks are very common. Remains of road-killed striped skunks, Mephitis mephitis, are frequent along the highway running through the orchard. Burrowing mammals appear rare

Table 1.--Birds observed in the pecan orchard. Nomenclature and order follow A.O.U. Checklist 1983. Abundance and status refer only to the orchard, not the surrounding desert and urban areas. Codes: Abundance: A=Abundant, C=Common, U=Uncommon, R=Rare; Status: V=Visitor B=Breeds, ?=Unknown; \*=Characteristically Riparian Habitat Dependent.

Turkey Vulture <u>Cathartes aura</u> CV	Cactus Wren <u>Campylorhynchus brunneicapillus</u> CV
Northern Harrier <u>Circus cyaneus</u> RV	Bewick's Wren <u>Thryomanes bewickii</u> U?
Sharp-shinned Hawk <u>Accipiter striatus</u> UV	Ruby-crowned Kinglet <u>Regulus calendula</u> UV
Cooper's Hawk <u>Accipiter cooperi</u> CV	American Robin <u>Turdus migratorius</u> UV
Harris' Hawk <u>Parabuteo unicinctus</u> RV	Northern Mockingbird <u>Mimus polyglottos</u> UV
Swainson's Hawk <u>Buteo swainsoni</u> CV	Curve-billed Thrasher <u>Toxostoma curvirostre</u> UV
Red-tailed Hawk <u>Buteo jamaicensis</u> AV	Water Pipit <u>Anthus spinoletta</u> UV
American Kestrel <u>Falco sparverius</u> CV	Loggerhead Shrike <u>Lanius ludovicianus</u> RV
Peregrine Falcon <u>Falco peregrinus</u> RV	European Starling <u>Sturnus vulgaris</u> AV
Gambel's Quail <u>Callipepla gambelii</u> AB	Lucy's Warbler <u>Vermivora luciae</u> AB
Killdeer <u>Charadrius vociferus</u> RV	Yellow Warbler <u>Dendroica petechia</u> AB*
Rock Dove <u>Columba livia</u> RV	Yellow-rumped Warbler <u>Dendroica coronata</u> AV
White-winged Dove <u>Zenaida asiatica</u> AB	Western Tanager <u>Piranga ludoviciana</u> UV
Mourning Dove <u>Zenaida macroura</u> AB	Black-headed Grosbeak <u>Pheucticus melanocephalus</u> UV
Inca Dove <u>Columbina inca</u> CB	Blue Grosbeak <u>Guiraca caerulea</u> CB*
Common Ground-Dove <u>Columbina passerina</u> CB	Lazuli Bunting <u>Passerina amoena</u> RV*
Yellow-billed Cuckoo <u>Coccyzus americanus</u> CB	Abert's Towhee <u>Pipilo aberti</u> RB*
Greater Roadrunner <u>Geococcyx californianus</u> CV	Chipping Sparrow <u>Spizella passerina</u> UV
Common Barn-Owl <u>Tyto alba</u> RV	Lark Sparrow <u>Chondestes grammacus</u> UV
Lesser Nighthawk <u>Chordeiles acutipennis</u> CV	Song Sparrow <u>Melospiza melodia</u> U?*
Common Poorwill <u>Phalaenoptilus nutallii</u> CV	White-crowned Sparrow <u>Zonotrichia leucophrys</u> AV
Black-chinned Hummingbird <u>Archilochus alexandri</u> CV	Red-winged Blackbird <u>Agelaius phoeniceus</u> AV*
Gila Woodpecker <u>Melanerpes uropygialis</u> CV	Western Meadowlark <u>Sturnella neglecta</u> CV
Ladder-backed Woodpecker <u>Picoides scalaris</u> CV	Yellow-headed Blackbird
Northern Flicker <u>Colaptes auratus</u> CV	<u>Xanthocephalus xanthocephalus</u> RV*
Black Phoebe <u>Sayornis nigricans</u> U?*	Brewer's Blackbird <u>Euphagus cyanocephalus</u> UV
Say's Phoebe <u>Sayornis saya</u> CB	Great-tailed Grackle <u>Quiscalus mexicanus</u> A?*
Vermilion Flycatcher <u>Pyrocephalus rubinus</u> R?*	Bronzed Cowbird <u>Molothrus aeneus</u> UB*
Western Kingbird <u>Tyrannus verticalis</u> AB*	Brown-headed Cowbird <u>Molothrus ater</u> CB
Purple Martin <u>Progne subis</u> UV	Hooded Oriole <u>Icterus cucullatus</u> U?*
Violet-green Swallow <u>Tachycineta thalassina</u> UV	Norther Oriole <u>Icterus galbula</u> U?*
Northern Rough-winged Swallow	House Finch <u>Carpodacus mexicanus</u> AB
<u>Stelgidopteryx serripennis</u> UV	Lesser Goldfinch <u>Carduelis psaltria</u> AB*
Common Raven <u>Corvus corax</u> AV	House Sparrow <u>Passer domesticus</u> UV

or uncommon, probably because their homes would be flooded by the irrigation water. Pocket gopher, Thomomys bottae, sign is uncommon. No rodent trapping has been done in the area, so the rodent fauna is largely unknown. Cotton rats, Sigmodon hispidus, have been seen in the orchard. Rock squirrels, Citellus variegatus, are extremely abundant and are considered an important pest. They burrow in ditch banks and also live in the slash piles. The farmers estimate that over \$100,000 worth of nuts are consumed by rock squirrels each year (R. K. Walden, personal communication). Farm workers attempt to poison and shoot the squirrels.

#### MANAGEMENT

The farmers had no intention of creating wildlife habitat when they planted the orchard. But they do recognize the value of the wildlife that has moved into their farm. As part of their farm management, the farmers would like to minimize

negative effects of cultural techniques on the native wildlife and are reluctant to contaminate the environment with insecticides. The only economically important insect found in the orchard is the blackmargined aphid, Monellia caryella. The floodwater mosquitoes are not considered an economic pest, but a nuisance and public health pest. Considerable political pressure has been applied on the growers to combat the mosquitoes. Options for mosquito control are limited. Few chemical insecticides are legally labeled for us on pecans, and no insecticide is specifically labeled for killing mosquitoes in pecans. Several chemicals are labeled for use for aphid control on pecans. Most of those chemicals will also kill mosquitoes, and were formerly used in an inefficient attempt to control mosquitoes. The growers are concerned that overuse of chemicals to combat mosquitoes may cause resistance to chemicals to develop in the aphids and might kill beneficial insects. My research over the past three years has been primarily directed toward development of techniques for the use of a bacterial mosquito larvicide, Bacillus

*thuringiensis israelensis*, also called BTI. BTI is an effective mosquito larvicide that is harmless to nontarget organisms (Garcia et al. 1981), Mulligan and Schaefer 1981, and is exempt from tolerances on food crops because of its proven safety. The treatment regime proved to be highly successful in the 1984 irrigation season. For the first time in many years, not a single mosquito complaint was received by the county health department, and it was possible to work comfortably in the orchard.

In conclusion, it appears that a land-use decision based upon economic considerations has resulted in the creation of a new type of agricultural ecosystem that closely resembles a declining native habitat. The new habitat has been settled by native animals, and the development of a distinctive biotic community is apparent and should be studied over time. Some native animals that are becoming rare because their habitat is disappearing are becoming settled and abundant in the pecan orchard. At the same time, mosquitoes, undesirable residents of native riparian wetlands, have found good habitat as well, and created problems for the human population. A management plan for the pests has been developed that takes into account the value of the nontarget organisms in and around the orchard and works with the biology of the mosquitoes, using the softest possible approach to solving a difficult problem.

Acknowledgements: I wish to thank R. R. Johnson, W. L. Nutting, F. G. Werner, and R. L. Smith for reviewing the manuscript and contributing helpful suggestions, and Typing Unlimited for typing the final copy.

#### LITERATURE CITED

- Bach, D. and J. R. Kuykendall. 1971. Trickle irrigation for pecan orchards. *Pecan Quarterly* 5(2):11-15.
- Conine, K. H., B. W. Anderson, R. D. Ohmart, and J. F. Drake. 1978. Responses of riparian species to agricultural habitat conversions. pp. 248-262. In: R. R. Johnson and J. F. McCormick (tech. coords.). *Strategies for Protection and Management of Floodplain Wetlands and Other Riparian Ecosystems*. Proceedings of the Symposium. USDA For. Serv. Gen. Tech. Rpt. WO-12, Washington, D.C. 410 pp.
- Corbet, P. S. 1980. Biology of Odonata. *Ann. Rev. Entomol.* 25:189-217.
- Couch, G. A. 1981. Wildlife control in pecans. *Proc. Texas Pecan Growers Assoc.* 60:52-55.
- Gaines, D. 1977. The valley riparian forests of California: their importance to bird populations. pp. 57-85. In: A. Sands (ed.) *Riparian Forests in California, Their Ecology and Conservation*. Div. of Agric. Sciences, Univ. of Calif. Priced pub. 4101, 122 p.
- Garcia, R. B. Desrochers, and W. Tozer. 1981. Studies on *Bacillus thuringiensis* var. *israelensis* against mosquito larvae and other organisms. *Proc. Calif. Mosquito Control Assoc.* 49:25-29.
- Hinman, E. H. 1934. Predators of the Culicidae (mosquitoes). II. Predators of adult mosquitoes. *J. Trop. Med. and Hyg.* 37:145-150.
- Johnson, R. R. and S. W. Carothers. 1982. Riparian Habitat and Recreation: Interrelationships and Impacts in the Southwest and Rocky Mountain Region. *Eisenhower Consortium Bulletin* 12, 31 p. Rocky Mountain Forest and Range Experiment Station, Forest Service, U.S. Dept. of Agriculture, Fort Collins, Colo.
- Martin, A. C., H. S. Zim and A. L. Nelson. 1951. *American Wildlife and Plants*. 500 p. Dover, New York.
- Mielke, E. A. and L. F. True. 1981. Pecans in Arizona. 12 p. Cooperative Extension Service, University of Arizona, Tucson.
- Mulligan, F. S. III and C. H. Schaefer. 1981. Integration of a selective mosquito control agent *Bacillus thuringiensis* serotype H-14 with natural predator populations in pesticide-sensitive habitats. *Proc. Calif. Mosquito Control Assoc.* 49:30-35.
- Phillips, A., J. Marshall, and G. Monson. 1964. *The Birds of Arizona*. 212 p. Univ. of Arizona Press, Tucson.
- Walden R. K. 1970. Why and how to establish a pecan orchard in the West. *Proc. Texas Pecan Growers Assoc.* 49:43-47.
- Wells, D. B. W. Anderson, and R. D. Ohmart. 1979. Comparative avian use of Southwestern citrus orchard and riparian communities. *J. Ariz.-Nev. Acad. Science* 14:53-58.
- Wolstenholme, B. N. 1979. The ecology of pecan trees, part 1: Characteristics of the native habitat. *Pecan Quarterly* 13(2)32-35.

# Relationships Between the Expansion of Agriculture and the Reduction of Natural Riparian Habitat in the Missouri River Floodplain of Northeast Montana, 1938-1982<sup>1</sup>

Alexander R. Hoar and Michael J. Erwin<sup>2</sup>

---

Abstract.--The floodplain composition is described for four points in time over a 45-year period. Broad changes in the area, density, and percent of the floodplain represented by agricultural and other developed land and three general riparian cover types are documented. Evidence is provided of the patterns and rates at which riparian cover types were lost and gained, including the conversion to agriculture and other developed types.

---

## INTRODUCTION

Human use of the floodplain zone has often resulted in the removal of the natural riparian vegetation. This reduction has been complete and permanent in some areas of the arid west (Ohmart et al. 1977). In the Sacramento River Valley of California, the riparian forests have been reduced from an estimated 775,000 acres in the 1850's to less than 13,000 acres in 1980 (Haugen 1980). Approximately 90 percent of the cottonwood forests along the lower Colorado River was eliminated between 1600 and 1967, the major decline occurring between 1940 and 1967. Similar declines occurred on the Rio Grand River in New Mexico and Texas (Ohmart et al. 1977) and on the South Platte River in Colorado.

Why these changes have occurred is sometimes confounding, at other times straightforward. Ohmart et al. (1977) concluded that the demise of cottonwood forests on the lower Colorado River was directly related to changes in that system caused by upstream dams. Taylor (1982) studied a series of aerial photographs taken in 1940, 1954, and 1963 of a small mountain stream in California from which water had been diverted since 1940. He found that the riparian zone declined steadily throughout the 24-year period, failing to reach a state of equilibrium. He attributed the observed changes to the reduction of streambank recharge resulting from the annual dewatering of the stream. This in turn stressed the vegetation in the riparian zone. Johnson et al. (1976) found

that tree growth below dams on the Missouri River became less vigorous following control of river flows and flooding. Other contributing factors were reduction of groundwater recharge, soil moisture, soil nutrient enrichment, and seedbed availability.

The most permanent destruction of riparian habitat on the middle and upper portions of the Missouri River has been caused by federal water development projects. Between Gavins Point, South Dakota and the junction of the Madison, Gallatin, and Jefferson Rivers in Montana, 838 of the 1510 river miles (or 55 percent) must now be classified as reservoir rather than as free-flowing river (MTDNRC 1979, USCOE 1977 and 1981c). A compilation of land-cover types flooded by six dams (Fort Peck Dam not included) in this river reach provides evidence that 27 percent (219,800 acres) of the total pool areas formerly consisted of trees, shrubs, and marsh; 35 percent (293,800) was grassland; 19 percent (158,400 acres) was agriculture; 18 percent (152,000 acres) was river channel; while less than one percent (5000 acres) consisted of forb and upland cover types. Thus, approximately 62 percent of the area flooded by six dams on this reach was occupied by woodland/grassland vegetation (USCOE 1981 (a and b); USFWS 1946, 1948, 1950, and 1952).

Little is known about how much riparian vegetation has existed in those areas of the upper and middle Missouri River floodplain that have not been inundated by reservoirs. The largest concentration of remnant gallery forests and other riparian vegetation types on the Missouri River upstream from Gavins Point, South Dakota is believed to exist now along 190 river miles in northeast Montana and northwest North Dakota. This paper documents how much riparian cover, agriculture, and other development existed in this area at different times between 1938 and 1982.

---

<sup>1</sup>Paper presented at the first North American Symposium on Riparian Ecosystems and Their Management: Reconciling Conflicting Uses, Tuscon, Arizona, April 16-18, 1985.

<sup>2</sup>Wildlife biologists, Ecological Services, U.S. Fish and Wildlife Service, Billings, Mont.

Broad changes in the floodplain composition are documented. Some general patterns and causes of change are identified and put in perspective.

#### STUDY AREA

The study area included the forests and other riparian vegetation along a 186-mile reach of the Missouri River in northeast Montana. In addition to the riparian vegetation, the study area encompassed the remainder of the "historic" floodplain and the Missouri River. The terrestrial acreage of the floodplain varied between 180,134 and 185,526 acres, depending upon the water level of the river at the time the aerial photographs were taken.

The western boundary of the study area was Fort Peck Dam. The eastern boundary was near the confluence of the Yellowstone River in North Dakota. Specifically, it was the north-south section line located in T152N, R104W that falls between Sections 8 and 9; 16 and 17; 20 and 21; and 28 and 29. Because the north and south boundaries were the extreme outer limits of the Missouri River "historic" floodplain, all of the potential riparian zone was contained therein.

There were five cities either within or near the study area, none of which exceeded a population of 10,000. Most had less than 2500 residents. Farming and grazing were the main land-uses within the area during the period studied.

#### METHODS AND MATERIALS

Included below are general descriptions of the interpretative classification system, the aerial photography and its interpretation, field verification, map production, and the digitizing and data processing systems used during this project.

##### Land-Cover Classification System

A land-cover classification was used that included general surface features that could be reliably identified on new black and white aerial photographs produced from old negative film. The system was designed to be compatible with classifications already in existence for wetlands (Cowardin et al. 1979) and riparian vegetation (Bachelor et al. 1982), but also to include features developed by humans such as agriculture, roads, residential areas, and so on.

Understory vegetation was not part of the classification because it could not be identified on older photographs. Surface cover was classified in terms of the tallest visible layer of homogeneous areas. The interpretation process was standardized so that each surface feature was interpreted in a particular order on each photo and minimum recognized sizes were established for each type. These standards are presented in Table 1.

Table 1.--Standards for interpretation of surface features on the Missouri River floodplain.

Surface Feature	Order of Photo Interpretation	Minimum Polygon Size (acres)
Floodplain	1	N.A.
Urban/Ranchyard	2	0.25
Deciduous Woodland	3	0.25
Shrub-Scrub	4	0.25
Herbaceous	5	0.25
Agriculture	6	10.00
Rights-of-way	7	N.A.

##### Floodplain

The first order feature was the floodplain. It was defined as a relatively flat expanse of land bordering the Missouri River (but not including the river) and extending north and south to the extreme limits of the "historic" floodplain. Contained within the floodplain were all oxbows, historic meander lines, and other telltale signs of riverine activity. So that all of the land would be classified, islands were considered to be part of the floodplain. The floodplain boundary was largely based on natural rather than such man-made features as canals, railways, or highways.

Portions of the boundary between the upland and the floodplain, and many of the original terrace contours, were indiscernible on the 1982 film (due to recent agricultural grading of upper terraces). These boundaries were clearest on the 1938 black and white photography. Thus, the floodplain boundary delineated on the 1938 photography served as the boundary within which the photography of all subsequent eras was interpreted. The boundary was arbitrarily drawn across tributary rivers or streams as they entered the Missouri River floodplain. This boundary defined the limits of the study area.

##### Urban/Ranchyard

The Urban/Ranchyard category included rural, urban, residential, commercial, and multiple-use development. Some mature trees and "L"-shaped windbreaks associated with farm and ranch sites were sometimes included in this category. In such cases, the delineation of the "yard" was somewhat subjective, depending upon the various clues visible to the interpreter.

##### Deciduous Woodland

Riparian deciduous woodlands were categorized by percent-canopy closure. Stands with less than ten percent closure were incorporated into other categories; e.g., herbaceous or shrub-scrub. All stands with a canopy closure equal to or greater than ten percent were included in the woodland type. This type encompassed extensive woodland tracts, farm woodlots, stands in and between agricultural fields, and linear windbreaks not asso-

ciated with farm or ranch sites. Cottonwood (Populus spp.) was the predominant tree species in this category.

#### Shrub-Scrub

The riparian shrub-scrub category consisted of woody plants up to five meters tall with erect single or multiple stems in areas containing less than ten percent woodland canopy closure and more than 30 percent shrub cover. Where the canopy closure of shrubs did not fall within the bounds of these criteria, the area was classified according to the dominant vegetation type; e.g., deciduous woodland or herbaceous.

Some dominant shrub species were willow (Salix spp.), dogwood (Cornus stolonifera), green ash (Fraxinus pennsylvanica) and cottonwood (Populus spp.) saplings, western wild rose (Rosa woodsii), and snowberry (Symphoricarpos occidentalis). Other common woody shrub species included Russian olive (Elaeagnus angustifolia), buffaloberry (Shepherdia argentea), and choke-cherry (Prunus virginiana).

#### Herbaceous

The riparian herbaceous category consisted of areas with a woodland-canopy cover of less than ten percent and a shrub cover of less than 30 percent. Small, non-shrub clearings within a woodland or large areas of low vegetation outside the woodland boundary with no visible evidence of farming such as furrows or hay piles, were included within the herbaceous category. Grazing was a common land-use in areas classified as this type. This category included herbs, grasses, young willows and cottonwood seedlings, wildrose, and snowberry, as well as wetland species such as cattail (Typha latifolia). Many emergent wetlands were included within this cover type as was permanent water in oxbows, natural and man-made ponds, channels that had been dammed or naturally arrested, depressions, or excavations. This lumping was necessary because these features could not be reliably interpreted on the 1938-era photography; thus reliable comparisons could not have been made with successive eras.

#### Agriculture

Agriculture was defined as any land visibly disturbed for the purpose of producing or harvesting crops. Three types of agriculture were included in this feature: flood-irrigated, center-pivot irrigated, and non-irrigated. Pastureland for grazing was difficult to identify on a black and white print. It was not considered as a separate feature, but was incorporated into this and other cover types, such as the herbaceous, shrub-scrub, and deciduous woodland types.

#### Rights-of-way

Rights-of-way included areas developed as transportation and utility corridors. This type

typically consisted of the Burlington Northern Railway; and transmission, pipeline, and Interstate Highway corridors. Miscellaneous paved and gravel roads were not included here, but were included with whatever cover type was adjacent to them.

#### Aerial Photography

##### Coverage

Complete physical coverage for the 1938, 1956, 1974, and 1982 time periods was acquired from several sources. The photographic products for the three older eras consisted of 9x9 inch, black and white, contact prints. The 1982 coverage was Kodak 2443 color infrared (CIR) film. The scale of all aerial photography was 1:24,000. These years were chosen because 1) photographic coverage for the entire area was available; 2) the Fort Peck Dam was completed in 1938, and 3) the years span a reasonable time period within which change could be assessed.

##### Adequacy

The black and white aerial photography used for this project was the best available. The resolving quality was generally adequate for feature identification, but considerable time was required for "keying-out" the textural, depth, and height characteristics of the surface-cover types. Poor exposure control of the black and white photography reduced the contrast on some frames, especially those of 1938 vintage. In some cases, gray tones were not consistent for the same feature on two adjacent frames and there was lack of full stereo coverage. Quality of the negatives improved substantially for eras after 1938.

The 1982 CIR film had excellent resolving and exposure qualities, but no stereo coverage. Overall, the 1982 film presented distinct contrasts between features, very sharp resolution, and appropriate mid-day shadows, which assisted in making height determinations. However, classifying dense stands of cottonwood trees was difficult if they approached the height limits of the shrub-scrub and woodland categories.

#### Data Processing

Photointerpretation and digitizing was done by the U.S. Fish and Wildlife Service in Fort Collins, Colorado. The process of interpreting the aerial photography was divided into several phases: field orientation, interpretation, overlay production, field verification, and quality control.

Field orientation was conducted during late July of 1981. Reference points for most features in the classification system were located on the ground, photographed, and marked on aerial photographs. These reference points provided a standard for interpretation throughout the project.



Aerial photos covering 100 percent of the floodplain were interpreted using an eight-power lens and the naked eye. Delineations were made on acetate overlays. Quality control and interpretative consistency was achieved during this phase by specialists each regularly examining the other's work.

Mylar overlays for twenty-eight 1:24000 scale, USGS topographic maps were produced by standard zoom-transfer processes. Ground truthing of these final interpretative products for the 1974 and 1982 eras was accomplished during a low-altitude flight over the entire length of the study area; during a roadside survey along a 23-mile length of secondary highway; and during visits to preselected sites.

Mylar overlays for each era were digitized using the WAMS (Wetland Analytical Mapping System) digitizing system. Data analyses were performed using a geographic information system, WINDOW, developed by the U.S. Fish and Wildlife Service. A Control Data Cyber 750 mainframe computer was used for data processing.

#### RESULTS AND OBSERVATIONS

How much riparian vegetation existed in north-east Montana along the Missouri River during 1938, 1956, 1974 and 1982 was investigated and is reported. Broad changes in the composition of the floodplain are documented. General patterns of change are described. Causes of change are discussed and their relative effects on floodplain composition are put in perspective. Riparian cover broadly included three cover types: the deciduous woodland (or forest), shrub-scrub, and herbaceous cover types. All areas of visible agricultural disturbance and hard construction were collectively referred to as developed cover or land. Developed cover included the agriculture, rights-of-way, and urban/ranchyard cover types. Developed cover was most often void of riparian vegetation.

The composition of the floodplain was not stagnant, but was dynamic throughout the period studied. Since 100 percent of the study area was inventoried for all four eras, no statistical analyses were performed. Differences were assumed to be real. Composition was described in terms of several measures. These were the area, density, and percent of the floodplain represented by each cover type. Broad changes were documented in terms of the net gain or loss of a cover type between eras.

General patterns are described based on these changes. These patterns and the magnitude of the changes were directly influenced by events caused by both humans and nature. These events included, but were not limited to, the conversion of riparian vegetation to cultivated farmland; the erosion of the shoreline by the Missouri River; the reduction of forests and shrubs by mechanical and chemical means as well as by burning; the abandonment of developed land and subsequent regrowth of riparian cover; the conversion of developed land to pastureland; natural succession; and growth. (Due to the height categories of the shrub-scrub and woodland types in the classification, plus inability to differentiate between the photographic signature of the herbaceous type and the seedling stage of woody species, homogeneous areas dominated by woody species could have been classified as any riparian type depending on whether the area was in a seedling, sapling, or mature stage of growth.) The effect of each event was not determined, but the results of cumulative effects were summarized in terms of broad categories of change.

#### Floodplain Composition

Several measures are presented in Table 2 for each cover type that together describe the floodplain composition in each era.

Table 2.--Floodplain cover types - Measures of composition by era.

Kinds of measurements	Developed Land			Riparian Habitat		
	Agriculture	Rights of way	Urban/Ranchyard	Deciduous Woodland	Herbaceous	Shrub Scrub
Percent of the floodplain						
1938	24	0.2	0.6	10	52	14
1956	47	0.4	0.9	16	25	11
1974	51	0.5	1.0	20	21	7
1982	55	0.5	0.8	13	26	5
Density (a./sq.mi.)						
1938	150	1	4	63	334	86
1956	301	2	6	101	158	71
1974	325	3	6	128	134	43
1982	349	3	5	81	168	34
Acres per cover type						
1938	43,592	434	1,173	18,374	96,804	25,037
1956	84,809	687	1,587	28,447	44,601	20,003
1974	94,263	992	1,792	37,082	38,849	12,548
1982	100,475	956	1,557	23,189	48,279	9,837

In 1938, the riparian herbaceous type occupied more than half (52 percent) of the floodplain. It was the dominant cover type. Agriculture, a development type, occupied approximately a quarter (24 percent) of the floodplain. It was the second-most dominant cover type. The shrub-scrub type occupied a larger percentage (14 percent) of the floodplain than did woodlands (10 percent). Urban/ranchyards and rights-of-way occupied the smallest percentages of the floodplain (0.6 and 0.2 percent, respectively).

In 1982, agriculture occupied over half (52 percent) of the floodplain. At this time, it was the dominant cover type. The herbaceous type occupied approximately a quarter (26 percent) of the floodplain. It was the second-most dominant type. The woodland type was the third most dominant cover type, while the shrub-scrub type was the fourth. Woodlands occupied 13 percent of the floodplain; the scrub-scrub type occupied only 5 percent. Urban/ranchyards and rights-of-way occupied small percentages of the floodplain. These were 0.8 and 0.5 percent, respectively. This order of cover dominance was set before 1956.

#### General Changes

Between 1938 and 1982, the total acreage of riparian cover declined by 58,910 acres (from 140,215 to 81,305 acres), while developed cover increased by 57,789 acres (from 45,199 to 102,988 acres). However, most of the decline of riparian cover occurred before 1956, by which time it had been reduced by 47,164 acres (from 140,215 acres to 93,051 acres). During this same time span, (1938-1956) developed cover increased by 41,884 acres (from 45,199 to 87,083 acres). The average annual decline of riparian cover between 1938 and 1956, was estimated to have been 2482 acres per year. The average annual increase of developed land was estimated to have been 2204 acres per year during the same period. The changes that occurred between 1938 and 1956 were the largest of the study period.

A list of cover types, ordered by percent of net change in acreage, would have agriculture in the number one position. Agriculture increased 130 percent over the entire study period; rights-of-way increased 120 percent; urban/ranchyards increased 33 percent; forests increased 26 percent; herbaceous cover decreased 50 percent; and the shrub-scrub type decreased 61 percent.

Of those cover types that increased, only agriculture increased throughout the study period. The maximum acreages for rights-of-way, urban/ranchyards, and woodlands appear to have occurred during the mid-1970's; by 1982, acreages for the latter two types were less than they had been since 1938. The rights-of-way category changed little between 1974 and 1982.

Observed changes in areal extent were not uniform for each type, nor were they similar between types, but a pattern was observed. Data presented in Table 2 provides evidence that the herbaceous type declined until 1974 and then in-

creased; shrub-scrub declined throughout the study period; and forests increased until 1974 and then declined. The largest decrease of herbaceous acreage took place between 1938 and 1956, when a net loss of 54 percent took place (52,203 acres; from 96,804 to 44,601 acres). The largest decline in the shrub-scrub type occurred between 1956 and 1974, when a net loss of 37 percent took place (7455 acres; from 20,003 to 12,548 acres). Between 1974 and 1982, 37 percent (13,893 acres; from 37,082 to 23,189 acres) of forests were eliminated. Forest acreages declined more than any other cover type between 1974 and 1982. Also during this period, the herbaceous acreage increased 9430 acres (from 38,849 to 48,279 acres). These patterns of riparian decline appear to be the result of the cumulative effects of several broad categories of change. The influence of each category is not detectable from the data presented in Table 2. Further analyses were necessary in order to place in perspective the patterns and causes of the riparian decline.

#### Causes of General Changes

The observed changes in the riparian types noted above resulted from three broad categories of loss or gain. These categories of change were: 1) loss to development, 2) loss to the River, 3) and loss (or gain) due to other causes.

An areal loss and a gain occurred whenever the classification of a parcel changed from one era to the next. For example, if woodland was converted to cropland, a "loss" would have occurred in the amount of woodland and a "gain" would have occurred in the amount of cropland. But, when a woodland was cleared to create new pasture, a loss of woodland as well as a gain of herbaceous area would have occurred. And, if a stand of sapling cottonwoods had grown above the height category for the shrub-scrub type, a loss would have occurred for this type while a gain would have occurred in the amount of woodlands. Interactions such as these between cover types were not investigated. But, evidence is provided that adds another dimension to the broad patterns of change described above. Specifically, data are provided on the relative influence of each category of change on each riparian type.

The amount of loss (or gain) attributable to each category was measured for each riparian type during each time period. These amounts were then divided by the number of years in the period. Chronologically, these were 19, 18, and 8 years. These rates are presented in Table 3 in terms of acres per year. Estimating loss (and gain) as a rate, rather than as the sum of change, facilitated comparisons of change between periods of unequal length.

In order to simplify calculating the rates at which individual riparian types were lost, all developed types were combined. Between 1938 and 1982, approximately 97.5 percent (85,894 acres) of all riparian cover converted to a developed type was converted to agriculture, 1.7 percent (1498 acres) was converted to urban/ranchyards, and 0.8 percent (698 acres) was converted to rights-of-

Table 3.--Estimated loss (or gain) of riparian cover types attributable to categories of change over time.

Categories of change for each time period	Riparian Cover Types			
	Deciduous	Scrub	Herbaceous	Totals
	Woodland	Scrub	Herbaceous	Totals
acres/year				
Loss to development				
1938 through 1956	106	248	2123	2477
1956 through 1974	167	234	904	1305
1974 through 1982	455	218	1519	2192
Loss to the River				
1938 through 1956	52	109	237	398
1956 through 1974	26	40	28	94
1974 through 1982	96	159	118	373
Loss (gain) to other causes				
1938 through 1956	( 688)	( 92)	388	( 392)
1956 through 1974	( 673)	140	( 612)	(1145)
1974 through 1982	1185	( 38)	(2816)	(1669)

way. Since far more acres were converted to agriculture than all other developed types combined, the "loss to development" category, can be for the most part, be thought of as a "loss to agriculture" category.

"Loss to development" accounted for a large percentage (49 percent) of the total riparian losses during the entire period studied. Some of each riparian type was developed during every period, but substantially more of the herbaceous type was lost to development than any other type. Development accounted for 65, 64, and 79 percent (chronologically) of all herbaceous losses. The rate at which each riparian type was lost to development changed over time. The rate of loss declined for both the herbaceous and shrub-scrub types, while it increased for the forest type. It appears that as the amount of herbaceous and shrub area declined, more emphasis may have been placed on converting woodlands to agriculture.

"Loss to the river" included the loss of riparian cover from the shores of islands as well as the mainland, due to bank erosion by water. It also included loss of riparian cover from an area downstream from Fort Peck Dam, where earth was removed and used to construct the Dam. Since then this excavated area has filled with water. Floods occurred during the study period that influenced the amount of riparian cover lost to the river. A total of 12,238 acres of riparian cover was lost to the river during the study period. This type of loss accounted for only seven percent of the total riparian losses during the entire period. Less of each cover type was lost to the river than was lost to any other category during the same period.

"Loss (or gain) to other causes" accounted for all other effects of reduction and growth of riparian vegetation caused by humans and nature that resulted in the conversion of one type into another. A gain occurred whenever developed land reverted to riparian cover (28,932 acres in total), and when new riparian growth occurred on soil deposited by the river (not specifically calculated). The rate of change was quite volatile with each cover type undergoing periods

of loss and gain. Only three periods of loss occurred and they were staggered, one in each time period. The increase in forest loss attributable to this category was acute between 1974 and 1982, when a rate of gain of 673 acres per year dropped to a loss of 1185 acres per year.

#### CONCLUSIONS

There is much concern over the loss of riparian habitat, especially in the western United State, because of the importance of this habitat to fish and wildlife resources. Although studies conducted elsewhere have documented the loss of this habitat, information was not available on the status of riparian habitat on the Missouri River in Montana. This fact plus the observations of numerous biologists that rather large blocks (20 to 80 acres) of trees were being cleared in the mid-to-late 1970's along the reach of Missouri River reported upon here, with unknown habitat consequences, led to this study.

A cursory examination of data in Table 2 may lead one to believe, at least in the case of forests, that there is not much reason for concern about loss of this type in the study reach. There was actually more of the forest type in 1982 (23,189 acres) than there was in 1938 (18,374 acres). However, closer examination shows that there was an increase of forests from 1938 through 1974, followed by a substantial loss between 1974 and 1982. The data reflect a gain of 102 percent in this type in the 36-year interval between 1938 and 1974, followed by a 37 percent loss in just eight years between 1974 and 1982. Further confirmation of this reversal is shown in Table 3. The annual rate of "gain due to other causes" of the woodland type declined from about 680 acres per year between 1938 and 1974 to a loss of 1185 acres per year between 1974 and 1982. If the rate of loss observed between 1974 and 1982 continues into the future, there is valid reason to be concerned about the longevity of the cottonwood forests in this reach of river.

A simpler relationship was observed for the shrub-scrub type. Table 2 shows a steady decline from 1938 to 1982. From 1938 when there was 25,037 acres of this type, there was a decline to 9,837 acres by 1982.

The herbaceous cover type was consistently the most abundant riparian type within the floodplain and substantial losses of this type have also been documented. Data presented in Table 2 provide evidence that in 1938, 52 percent of the floodplain was classified as this type and that early in the study period (by 1956) the areal extent of this type had been reduced to just 25 percent of the floodplain.

"Loss to development" accounted for most of this reduction. During the early period, 42 percent (40,333 acres) of all herbaceous cover was "loss to development," predominantly cropland. Throughout the study period, most agricultural development has been on land formerly classified as this type.

Many wetlands that may have been included within the herbaceous and other cover types may have been lost or mechanically altered during the initial phases of agricultural development within the floodplain. These would probably have included seasonal and temporary wetlands that form in topographic depressions, as well as permanent wetlands in oxbows, channels that had been naturally arrested, and low areas of subterranean irrigation. Those that were not impacted during initial development may well have been altered due to agricultural grading of upper terraces, which by 1982 had been extensive enough to obliterate many of the original terrace contours from an aerial view. Wetlands are an important component of the riparian community, but were not included in the inventory or the subsequent analyses, due to the poor resolving power of the black and white prints that were available.

Information provided in this study provides some insights into how dynamic the surface composition of the riparian system has been in terms of agricultural development and natural events.

#### REFERENCES CITED

- Batchelor, R., M. Erwin, R. Martinka, D. McIntosh, R. Pfister, E. Schneegas, J. Taylor, K. Walter. 1982. A taxonomic classification system for Montana riparian vegetation types. USDA, Coop. Extension Service, Rural Areas Development Committee. MSU, Bozeman. 13 pp.
- Cowardin, L.M., V. Carter, F.L. Golet, E.T. LaRoe. 1979. Classification of wetlands and deepwater habitats of the United States. U.S. Fish and Wildlife Service, Biological Services Program; FWS/OBS-79/13. December. 103 pp.
- Haugen, G. 1980. Position paper on management and protection of western riparian stream ecosystems. American Fisheries Society - Western Div., Tualatin, Oregon. 24 pp.
- Johnson, W.C., R.L. Burgess, W.R. Keamnerer. 1976. Forest overstory vegetation and environment on the Missouri River floodplain in North Dakota. Ecological Monograph; 46:59-84.
- MTDNRC. 1979. River mile index of the Missouri River. Water Resources Div., Montana Dept. Natural Resources & Conservation. Helena. January. 142 pp.
- Ohmart, R.D., W.O. Deason, and C. Burke. 1977. A riparian case history: The Colorado River. USDA Forest Serv., Gen. Tech. Rpt. RM-43: 35-47.
- Taylor, D.W. 1982. Eastern Sierra riparian vegetation: ecological effects of stream diversions. Contribution No. 6, Mono Basin Research Group. (Rep. to Inyo National Forest.) 56 pp.
- USFWS. 1946. A report on the fish and wildlife problems in relation to the water development plan for the Canyon Ferry Reservoir: Missouri River, Montana. U.S. Fish and Wildlife Service. (on file with USFWS in Billings, Mont.).
- \_\_\_\_\_. 1948. Fort Randall Reservoir: A preliminary evaluation of the effect of the Fort Randall Dam and Reservoir on fish and wildlife resources. U.S. Fish and Wildlife Service. February. (on file with USFWS in Pierre, S.D.).
- \_\_\_\_\_. 1950. Lewis and Clark Lake: A preliminary evaluation report on fish and wildlife resources, Gavins Point Reservoir, South Dakota and Nebraska. U.S. Fish and Wildlife Service. August. (on file with USFWS in Pierre, S.D.).
- \_\_\_\_\_. 1952. A report on the development of fish and wildlife resources for Garrison Reservoir, Missouri River, North Dakota. U.S. Fish and Wildlife Service. September. (on file with USFWS in Bismarck, N.D.).
- USCOE. 1977. Missouri River, South Dakota, Nebraska, North Dakota, Montana: review report for water resources development. Appendix 1. Tech. Rpt. Vol 2 of 3, pp. B5-6 and B-55. Missouri River Div., Dept. of Army, Washington, D.C.
- \_\_\_\_\_. circa 1981a. Lake Sharpe: Final feasibility report/Final EIS, Lake Oahe/Lake Sharpe, South Dakota, fish and wildlife mitigation. Omaha District, Corps of Engineers, Dept. of Army, Omaha.
- \_\_\_\_\_. circa 1981b. Lake Oahe: Final feasibility report/Final EIS, Lake Oahe/Lake Sharpe, South Dakota, fish and wildlife mitigation. Omaha District, Corps of Engineers, Dept. of Army, Omaha.
- \_\_\_\_\_. circa 1981c. Flooded areas and profile, Vol. 4. Omaha District. Corps of Engineers, Dept. of Army, Omaha. March.

# Management Goals and Habitat Structure<sup>1</sup>

Henry L. Short<sup>2</sup>

---

Abstract.--Many management goals can be developed for riparian habitats. Each goal may dictate different management policies, strategies, and tactics and result in different impacts on wildlife. Habitat structure, expressed in terms of habitat layers, can provide a useful framework for developing effective strategies for a variety of management goals because many different land uses can be associated with habitat layers. Well-developed goals are essential both for purposeful habitat management and for monitoring the impacts of different land uses on habitats.

---

## INTRODUCTION

Habitat managers sometimes inadequately establish management goals for land units, like riparian habitats, which results in expensive and ineffective management and an inability to monitor changes in habitat quality. I demonstrate, in this paper, how different management goals affect the management policies, strategies, and activities developed for a land unit. I also discuss how some management strategies for achieving management goals can be modeled in terms of layers of habitat.

Management goals, policies, strategies, and tactics provide a hierarchical series of plans and actions. Management goals are a determination of the desired product from some land unit. The development of goals requires an understanding of what can be reasonably produced on that land unit. Goals may need to be developed in a workshop setting with advocates of different land uses as participants. Policy, in the examples below, is a commitment to achieve a particular habitat structure to attain a management goal. The management strategy in the following examples is a description of the particular habitat structure to be achieved in management. I describe species-habitat word models and simple optimization models as techniques for developing management strategies. Tactics are those activities used to produce the desired habitat structure required to attain the management goal. A discussion of procedures to evaluate the effects of management is beyond the scope of this paper.

---

<sup>1</sup>Contributed paper, Symposium on Riparian Ecosystems and Their Management, April 16-18, 1985, Tucson, AZ.

<sup>2</sup>Terrestrial Ecologist, Western Energy and Land Use Team, U.S. Fish and Wildlife Service, Fort Collins, CO 80526-2899

## NEED FOR A MANAGEMENT GOAL

The management goal for a riparian area needs to be well-defined. Policies, strategies, and tactics vary with different goals and result in different impacts on the area. Consider the two management options for the same riparian habitat listed in figure 1. The goal in the first example is to maximize plant and animal richness. The management policy, in this case, is to implement a system that will result in a diverse ecosystem. The management strategy is to determine the habitat structure that will best provide the diverse ecosystem. The goal for the same land unit in example two is to maximize forage yield for domestic livestock production. The management policy is to implement a grazing system that will maximize the production and use of forage over time. The management strategy is to produce a particular habitat structure where forage production can be maximized. The tactics chosen to meet the management goals obviously differ for these two examples.

An impact to a land unit can be considered positive or negative, depending on the management goal for that land unit. This fact is illustrated in figure 2. Reductions in the structure of habitat that reduce diversity in the riparian ecosystem would have a negative impact in example one but a positive impact in example two. On the other hand, an increase in structural diversity would result in reduced light penetration to the understory and less forage production for livestock. This change would have a positive impact in example one but a negative impact in example two.

## MODELING HABITAT STRUCTURE FOR MANAGEMENT

Goal setting is the most important activity in habitat management. The future appearance of

	<u>Example one</u>	<u>Example two</u>
Goal	To restore or preserve the integrity and diversity of wildlife and plant communities.	To maximize forage yield within the riparian zone for the production of domestic livestock.
Policy	Establish a management system that will produce a diverse ecological system.	Establish a management system that will maximize forage yield and use over time.
Strategy	Determine the habitat structure that will favor plant and wildlife diversity.	Determine a habitat structure that will maximize forage production.
Tactics	Modify habitat to provide and maintain a structure that favors plant and animal diversity.	<p>Modify the structure of vegetation within the riparian zone to maximize light penetration to the understory.</p> <p>Develop an irrigation system to maximize forage production.</p> <p>Develop a fencing system to regulate grazing at different seasons to intensively harvest forage over time without destroying grazing habitat.</p>

Figure 1. Different goals, policies, strategies, and tactics can be developed by users of riparian zones.

many riparian habitats depends on the establishment of management goals. In many instances, the goal will be formulated in terms of some product from that land, such as forage, fish and wildlife habitat, scenery, recreation opportunity, or timber, and the strategy for attaining the management goal will describe a vegetative structure to be established or restored that will yield the desired product.

The structure desired for riparian habitats often can be represented in terms of habitat layers, such as surface water, terrestrial subsurface, understory, midstory, tree bole, and overstory (Short and Burnham 1982; Short 1983).

<u>Impacts</u>	<u>Example one</u>	<u>Example two</u>
Develop multi-layered vegetative cover	positive	negative
Limit grazing	positive	negative
Maximize understory vegetative cover	negative	positive

Figure 2. An impact can be either positive or negative, depending on the management goal for a land unit.

The advantage of such a representation is that many land uses can be considered in terms of how they impact habitat layers. A variety of different land uses can be considered in the same model of habitat structure. I indicate, in the following section, how two different management goals can be developed by considering habitat structure in terms of layers of habitat. These two goals are: (1) to restore or preserve breeding populations of selected wildlife species within the riparian zone; and (2) to restore or preserve a habitat structure that will allow managers to maximize products from a variety of land uses within the riparian zone. Other management goals also could be addressed, using the concept of layers of habitat as a common denominator for expressing habitat structure.

#### Management for Wildlife Values

A riparian zone can be managed to maximize wildlife diversity or to favor selected wildlife species. The following discussion describes management efforts to favor selected wildlife species. The goal, policy, strategy, and management tactics to favor this type of effort are summarized in figure 3. The goal is to restore or preserve breeding populations of selected species within the riparian zone; the management policy is to establish a management system that will meet that goal. The strategy is to determine a habitat structure that will allow the

goal to be attained. There are three intermediate steps between the policy and strategy levels in this planning hierarchy. These can be considered tools for determining the management strategy. The first tool is to determine the species to be favored in management. Species may be considered for selection either because they are listed in some legislative mandate or because they have been selected by some logical process, like the process for selecting species of "high concern" described by Short and Williamson (in prep.).

The second tool is to determine the habitat requirements of species of "high concern". These requirements can be summarized by developing simple species-habitat word models, like the one for the screech owl summarized in figure 4. The word models describe the layer of habitat (tree bole) where breeding occurs, the layer of habitat (understory with limited cover) where foraging occurs, and major habitat dependencies, such as the size of habitat blocks necessary or, in the case of the screech owl, a dependency on tree holes excavated by cavity-making birds. The word model is a generalization of the species-habitat information available in the literature.

The third tool is to summarize the information in the word models to yield a description of the habitat structure (layers) to be developed or maintained within the riparian zone. The summarization may be either descriptive or a matrix (Short and Williamson in prep.), which lists the structural conditions that occur within each layer of habitat. A portion of a matrix that lists habitat conditions in the understory layer where the screech owl feeds is reproduced in Table 1. The appropriate elements of the matrix are notated for each species of "high concern". The resulting pattern describes the conditions within layers of habitat that are to be restored or preserved by management actions. This is the management strategy for achieving the management goal.

- Goal: To restore or preserve breeding populations of selected wildlife species.
- Policy: Establish a management system that will restore or preserve habitat for the selected wildlife species.
- Strategy: Determine the habitat structure required to achieve the management goal.
- Tactics: Develop the habitat structure required by selected wildlife species. Maintain required habitat structure through time.

Figure 3. The goal, policy, strategy, and tactics for managing a riparian zone for its wildlife value.

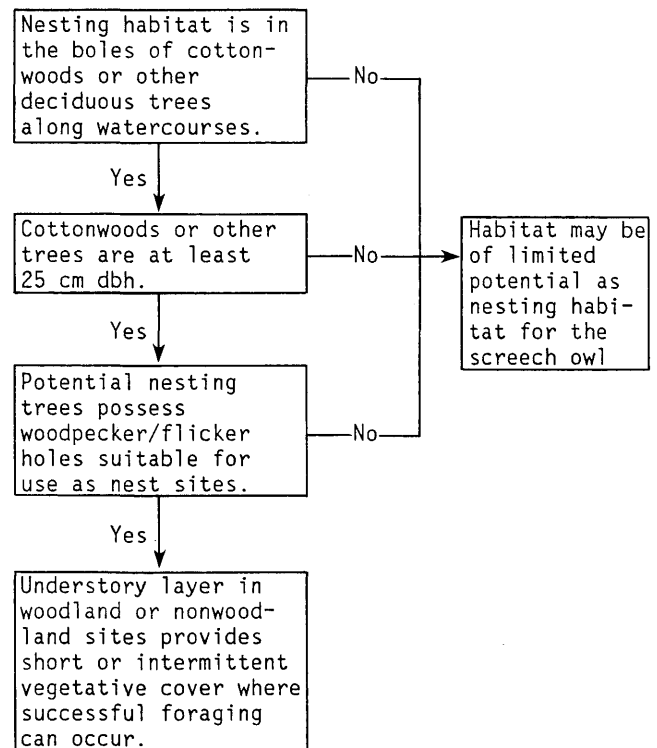

Figure 4. Simple word model describing the important characteristics of the nesting and foraging habitat of the screech owl.

Management tactics for the example in figure 3 are those that will produce and maintain the habitat structure that seems most important to the wildlife species of "high concern".

#### Multiple Use Management

The multiple use management goal listed in figure 5 is to restore or preserve a habitat structure that will optimize the products from a variety of land use options in a riparian habitat.

The management strategy in this example is to describe the appropriate habitat structure to meet the management goal. The models described below are simple optimization models, similar to those used in business planning (Wagner 1969). The models occur at the same level in the planning hierarchy as did the word model and the summary matrix in the previous section. The optimization models are tools for determining preferred management strategies. The major difference between business planning and the applications discussed in this paper is that the value of the products of habitat management usually are not expressed in monetary terms. It is difficult to consider a multiple use model in "market value" terms because not all legitimate land uses can be equally well represented in the market place.

The alternative is to give common scalar values to products of land uses such as grazing,

timber management, and wildlife management. Product values for such land uses are given the maximum value of 1.0 under some most favorable habitat structure configuration and are given the minimal value of 0.0 under some least favorable habitat structure configuration. Habitat structure configurations of intermediate quality are given intermediate product values in the models.

I have considered only the understory, midstory, and overstory layers of habitat in this analysis of vegetative structure because the tree bole layer is produced at the same ecological cost as is the overstory layer and the two layers are highly dependent variables.

Two alternative examples for multiple use management are described below. The two alternatives exist because the riparian systems differ in the two examples. Example A, in figure 6, determines the desired habitat structure for a large riparian area where wildlife species breed and forage mostly within the riparian area.

Table 1.--A large variety of structural conditions occurs within the understory layer of habitat, and the use of particular conditions by the screech owl and other species of "high concern" can be summarized in a matrix format.

Structural condition	Screech owl requirements
Understory layer	
salt playas	
bare ground (sand to rubble)	
boulder-covered surface	
talus, unvegetated	
talus, vegetated	
cliff-ledge or cavity near valley floor	
cliff-ledge or cavity near mesa or mountain top	
woody litter (includes shrub branches, tree branches, and stumps) < 50% cover	X
woody litter ≥ 50% cover	
herbaceous vegetation - short (< 0.5 m)	
sparse ≤ 33% cover	X
moderate 34 to 66% cover	
dense ≥ 67% cover	
herbaceous vegetation - (≥ 0.5 m)	
sparse ≤ 33% cover	X
moderate 34 to 66% cover	
dense ≥ 67% cover	
supine or dwarf woody vegetation	
sparse ≤ 33% cover	
moderate 34 to 66% cover	
dense ≥ 67% cover	
cactus stems and pads	
sparse ≤ 33% cover	
moderate 34 to 66% cover	
dense ≥ 67% cover	

Goal: To restore or preserve habitat structure that will allow managers to maximize products from a variety of land uses within the riparian zone.

Policy: Establish a management system that will optimize products of different land uses from the riparian zone.

Strategy: Determine the habitat structure that will maximize values from the potential land uses.

Tactics: Develop the habitat structure that will optimize production from a variety of land uses within the riparian zone. Maintain that habitat structure through time.

Figure 5. The goal, policy, strategy, and tactics for managing a riparian zone to optimize production from a variety of land uses.

Example B, in figure 6, determines the desired habitat structure for a limited riparian habitat in which species may breed but where many of the species rely on cover types away from the riparian area for foraging activities. The two examples in figure 6 illustrate how different strategies may exist for attaining the same goal in two different habitats where the wildlife values are perceived differently.

Products from land uses like grazing, timber management, and wildlife management can be considered products of particular layers of habitat. Grazing products are maximized in the riparian area in both examples when the overstory and midstory layers are absent and there is maximum sunlight penetration to the understory. The value of the grazing product is 1.0 in both examples when only the understory layer is present; 0.3 in example A when the overstory, midstory, and understory layers are equally abundant because less forage is available for livestock; and 0.1 in both examples when the only understory vegetation is the early regenerative stage of treelands.

Timber management products are maximized in both examples when most of the riparian area is in trees and tree boles are allowed to mature to a stage useful for cutting. Some small portions of the treeland should be in regenerative stages, so that early successional (understory) and mid-successional (midstory) stages also are present. The value of the timber product is 1.0 when extensive portions of the riparian area are in overstory vegetation; 0.4 in example A when the areas of overstory, midstory, and understory vegetation are similar and the forested area is reduced; and 0 in both examples if only the understory layer is present.

Wildlife species richness is favored in example A and species richness is presumed to be enhanced when the overstory, midstory, and understory layers each are present and equally



Example A  
Matrix Summarizing Multiple Use Problem

	Portion of each layer to maximize		
	Grazing	Wildlife	Timber
Overstory	0	0.34	0.7
Midstory	0	0.33	0.2
Understory	1.0	0.33	0.1
Values of the products			
Grazing	1.0	0.3	0.1
Wildlife	0.2	1.0	0.4
Timber	0	0.4	1.0
Total Values	1.2 (P <sub>1</sub> )	1.7 (P <sub>2</sub> )	1.5 (P <sub>3</sub> )

Objective function:  $1.2 P_1 + 1.7 P_2 + 1.5 P_3$

Constraints:  $P_1 \leq 1.00$        $P_1 \geq 0.10$   
 $P_2 \leq 1.00$        $P_2 \geq 0.10$   
 $P_3 \leq 1.00$        $P_3 \geq 0.10$   
 $P_1 + P_2 + P_3 \leq 1.00$

Solution for variable value:  $P_1 = 0.10$   
 $P_2 = 0.80$   
 $P_3 = 0.10$

Solution to determine quantity of different layers of habitat:

$$\text{Overstory} = (0 \times 0.1) + (0.34 \times 0.8) + (0.7 \times 0.1) = 0.34 = 34.3\%$$

$$\text{Midstory} = (0 \times 0.1) + (0.33 \times 0.8) + (0.2 \times 0.1) = 0.28 = 28.3\%$$

$$\text{Understory} = (1.0 \times 0.1) + (0.33 \times 0.8) + (0.1 \times 0.1) = 0.37 = 37.4\%$$

Example B  
Matrix Summarizing Multiple Use Problem

	Portion of each layer to maximize		
	Grazing	Wildlife	Timber
Overstory	0	0.7	0.7
Midstory	0	0.2	0.2
Understory	1.0	0.1	0.1
Values of the products			
Grazing	1.0	0.1	0.1
Wildlife	0.2	1.0	1.0
Timber	0	1.0	1.0
Total Values	1.2 (P <sub>1</sub> )	2.1 (P <sub>2</sub> )	2.1 (P <sub>3</sub> )

Objective function:  $1.2 P_1 + 2.1 P_2 + 2.1 P_3$

Constraints:  $P_1 \leq 1.00$        $P_1 \geq 0.10$   
 $P_2 \leq 1.00$        $P_2 \geq 0.10$   
 $P_3 \leq 1.00$        $P_3 \geq 0.10$   
 $P_1 + P_2 + P_3 \leq 1.0$

Solution for variable value:  $P_1 = 0.10$   
 $P_2 = 0.45$   
 $P_3 = 0.45$

Solution to determine quantity of different layers of habitat:

$$\text{Overstory} = (0 \times 0.10) + (0.7 \times 0.45) + (0.7 \times 0.45) = 0.63 = 63\%$$

$$\text{Midstory} = (0 \times 0.10) + (0.2 \times 0.45) + (0.2 \times 0.45) = 0.18 = 18\%$$

$$\text{Understory} = (1 \times 0.10) + (0.1 \times 0.45) + (0.1 \times 0.45) = 0.19 = 19\%$$

Figure 6. Matrices, linear program algorithms, and solutions of two alternatives for the multiple use management of riparian habitats.

distributed throughout the riparian zone. Data in Short (1983) indicated that species richness is maximum when the number of layers of habitat on a land unit is maximum. The value of the wildlife product in example A in figure 6 is 1.0 when the overstory, midstory, and understory layers are present and equally abundant throughout the riparian zone, 0.2 when only the understory layer is present, and 0.4 when most of the riparian zone is a mature treeland with only limited quantities of understory and midstory present. The value of the wildlife product in example B is maximized when a large portion of the land area is covered by overstory vegetation that provides nest sites for species that forage in non-riparian cover types. The value of the wildlife product is 1.0 in example B for the same structural condition for which timber values were maximized.

The structure to be favored in multiple use management in these very simplified examples was

determined by maximizing the values present for the three management options in examples A and B. This was accomplished by using the LINDO Computer Program (Schrage 1984) to solve the two linear programming problems. Multiple use values in example A are maximized when overstory, midstory, and understory are each dominant over about equal portions of the riparian area. Multiple use values in example B are maximized when overstory conditions predominate on the riparian area. The solutions for examples A and B differ because wildlife values are different in A and B. More explicit statements of the desired habitat structure in example A and B were obtained by using the values for  $P_1$ ,  $P_2$ , and  $P_3$  to estimate the quantities of each layer of habitat to be produced and maintained in the riparian habitats. These quantities represent the management strategies required to attain the management goal listed in figure 5. The quantity of each layer of habitat desired was estimated by summing, for each habitat layer (overstory,

## SUMMARY

midstory, and understory), the product of the quantity of that layer in each land use option and the relative value contribution of each land use option. This value is expressed as a percent of the summed total of the products of the layer quantity x relative value contributions. In example A, the products for the overstory layer were  $(0 \times 0.10) + (0.34 \times 0.80) + (0.70 \times 0.10)$ , which equals 0.34 (fig. 6). This value is 34.3% of the summed total of the products of the nine individual layer quantity x relative value contribution combinations (0.99 in fig. 6). In like manner, the desired quantity of midstory vegetation was calculated as 28.3% of the land area, and the desired quantity of understory vegetation was calculated as 37.4% of the land area. The strategy for attaining the multiple use management goal for the habitat conditions listed in example A in figure 6 is to produce a habitat where the overstory is dominant on 34% of the land area, the midstory is dominant on 28% of the land area, and the understory is dominant on 37% of the land area.

The same type of solution for example B describes a very different habitat structure. Based on the same type of calculations, the management strategy in this example is to produce a habitat where the overstory is dominant on 63% of the land area, the midstory is dominant on 18% of the land area, and the understory is dominant on 19% of the land area (figure 6).

The tactics to achieve the multiple use management goals in both example A and example B include the application of grazing and timber management practices that will obtain and maintain the desired habitat structures across time.

These two examples indicate that establishing different objectives for a wildlife resource can influence the habitat structure required as a management strategy to attain a multiple use management goal.

The efficient management of riparian habitats requires the formulation of an explicit management goal for a land unit and the development of the appropriate management policies, strategies, and activities to achieve that goal. Setting goals enhances the efficiency of habitat management and helps managers evaluate the impacts of potential land use changes. Vegetative structure of riparian areas, expressed in terms of layers of habitat, is a habitat criterion that can be used in modeling to help develop management strategies and predict impacts on habitats.

## ACKNOWLEDGEMENTS

I appreciate Adrian Farmer's help in formulating the linear programming models and helpful reviews by Samuel C. Williamson, Carl Armour, and Charles Segelquist. Cathy Short edited the paper and Jennifer Shoemaker prepared the manuscript for camera reproduction. Carolyn Gulzow and Dora Ibarra provided the word processing.

## LITERATURE CITED

- Schrage, Linus. 1984. User's manual. Linear, integer, and quadratic programming with LINDO. 86 pp. The Scientific Press, Palo Alto, CA.
- Short, Henry L. 1983. Wildlife guilds in Arizona desert habitats. USDI Bureau of Land Management Tech. Note 362. 258 pp.
- Short, Henry L., and Kenneth P. Burnham. 1982. Technique for structuring wildlife guilds to evaluate impacts on wildlife communities. USDI Fish Wildlife Service, Special Scientific Report - Wildlife 244. 34 pp.
- Short, Henry L., and Samuel C. Williamson. A procedure for selecting cover types for management. in prep.
- Wagner, Harvey M. 1969. Principles of operations research. 937 pp. + append. Prentice-Hall, Inc., Englewood Cliffs, NJ.

# Streamside Management Zones and Wildlife in the Southern Coastal Plain<sup>1</sup>

James G. Dickson and Jimmy C. Huntley<sup>2</sup>

---

Abstract.--We are assessing the impacts of presence and vegetative composition of Streamside Management Zones (SMZ) on squirrels, deer, furbearers, small mammals, birds, reptiles, and amphibians. Preliminary results for squirrels show gray and fox squirrels were abundant in the wide SMZ, but virtually absent from medium and narrow SMZ.

---

## INTRODUCTION

There are some 81 million ha in commercial forests in the southern coastal plain. On much of this land, especially industrial forest land, mature mixed pine-hardwood forests are being cut and replaced by pine (*Pinus* spp.) plantations. In young pine plantations a large variety and quantity of herbaceous and woody vegetation make young plantations good wildlife habitat for many species of wildlife. White-tailed deer (*Odocoileus virginianus*), cotton rats (*Sigmodon hispidus*), cottontail rabbits (*Sylvilagus floridanus*), and many birds fare well in young clearcuts. But wildlife habitat for most species deteriorates after 7 to 10 years when pine canopies close and non-pine vegetation dwindles.

Mature vegetation along permanent and intermittent streams bisecting upland sites often is retained to reduce non-point source pollution and to enhance wildlife habitat. These areas of hardwood or mixed pine-hardwoods are called stringers, streamers, or streamside management zones. Streamside Management Zones (SMZ) throughout a pine plantation create habitat diversity and edge. They serve as corridors and are limited habitat for species associated with mature forests. Nesting sites, food, and cover probably are increased for many species of wildlife. Hard and soft mast are produced by the residual trees, and nesting and foraging sites are provided by the shrub and canopy vegetation. Studies have shown that floodplain forests support more birds than upland pine stands (Dickson 1978, Stauffer and Best 1980), probably due to their greater vegetation structural diversity. Bottomland hardwood forests are also prime habitat for white-tailed deer

(Stransky and Halls 1968). In Mississippi, time-area counts of squirrels (*Sciurus* spp.) was higher in SMZ than in pine-hardwood stands (Warren and Hurst 1980). In eastern Texas, McElfresh et al. (1980) captured squirrels regularly in Sweetbay Magnolia-Redbay Persea "stringers" but rarely in adjacent pine plantations. Retention of mature vegetation along streams in clearcuts has been recommended for deer, turkeys (*Meleagris gallopavo*), squirrels, and song birds. In the south the retention of SMZ in clearcuts is policy for the U.S. Forest Service and several large industrial forest landowners.

Quantitative data on effects of SMZ on wildlife populations are generally lacking. Wildlife managers are being asked to justify retention of SMZ in land-use plans on a biological and economical basis. What differences do SMZ make in populations of various species? What differences are there in wildlife populations in areas with SMZ and areas without SMZ? What are the relationships between SMZ width and vegetative composition, and wildlife abundance? The Wildlife Habitat and Silviculture Laboratory, Southern Forest Experiment Station, USDA Forest Service is conducting research to help answer these questions by assessing the impact of presence, vegetative composition, and extent of SMZ on various segments of the wildlife community. The purpose of this paper is to provide background information on the nature of SMZ in the southern coastal plain, present approach and techniques for our research, and outline tentative results for one animal group.

## METHODS

Nine recent clearcuts 2-4 years old, from 49 to 121 ha in size and located in East Texas were selected for study areas. Selection of nine areas was based on similarity of topography, soils, vegetation, and surrounding land use. All areas were previously vegetated by second growth pine-hardwoods, had been recently clear-cut, mechanically site prepared, planted to loblolly pines (*Pinus taeda*) and were traversed by SMZ. Pines were generally 0.5 to 1.5m

---

<sup>1</sup>Paper presented at the North American Riparian Conference. [University of Arizona, Tucson, April 16-18, 1985].

<sup>2</sup>James G. Dickson is Supervisory Research Wildlife Biologist and Jimmy C. Huntley is a Research Wildlife Biologist for USDA Forest Service, Southern Forest Experiment Station, Wildlife Habitat and Silviculture Laboratory, Nacogdoches, TX. (In cooperation with School of Forestry, Stephen F. Austin State University)

high. The stands were dominated by hardwood browse, and other woody and herbaceous vegetation. Oak (*Quercus* spp.) and hickory (*Carya* spp.) sprouts, *Callicarpa americana*, *Rubus* spp., and *Rhus* spp. were abundant. Dominant overstory vegetation in SMZ included southern red oak (*Quercus falcata*), white oak (*Q. alba*), post oak (*Q. stellata*), sweetgum (*Liquidambar styraciflua*), and American beech (*Fagus grandifolia*). Assigned treatments were SMZ of 3 widths; narrow SMZ (< 20 m wide), medium SMZ (25-50 m), and wide SMZ (> 50 m). Three replications of each treatment were applied. Four sample transects (200 m each) have been established in each of the 9 study areas--2 in the SMZ and 2 in the adjoining pine plantation. Along each transect, understory, midstory, and overstory vegetation has been sampled from 4 points on each transect. Additionally, hard mast is being sampled from visual estimates corrected by collection in barrels.

The vertebrate community is being sampled by various means. Deer tracks and pellet groups are being counted on plots in SMZ and plantations. Scent stations baited with bobcat urine and fish oil are used to survey furbearers. Small mammal abundance is being determined from live trapping and marking. Bird censuses from transects during winter and the breeding season are being conducted. Reptiles and amphibians in SMZ and plantation slopes are being surveyed by visual counts, by inspection of artificial covers, and by captures from drift fences and funnel traps.

Gray squirrel (*Sciurus carolinensis*) and fox squirrel (*Sciurus niger*) abundance was estimated with time-area counts on 6 of the 9 study areas, 2 each with narrow, medium, or wide streamside management zones (SMZ). Four observation points at least 100 m apart were located in each SMZ. Three counts were conducted by different observers for a total of 12 observation periods in each SMZ. Observation time at each point was 20 minutes as recommended by Bouffard and Hein (1978). Counts were conducted in late September before squirrel hunting season, between 0700 and 1030 hours.

## RESULTS

Squirrels were detected regularly in the wide SMZ, and rarely in the medium SMZ. None were detected in the narrow SMZ. Total squirrels seen were 4 and 8 in wide SMZ, 0 and 1 in medium SMZ, and none in either narrow SMZ.

The number of squirrels seen per hour in the wide, medium, and narrow was respectively 1.5, 0.1, and 0.0. No squirrels were seen using the young (2-4 years old) pine plantations that surround the SMZ.

Substantial detections plus numerous signs of heavy feeding indicate that squirrels were permanent residents in the 2 wide SMZ, which averaged 93 m and 73 m in width. The 2 medium SMZ, which averaged 36 m and 37 m in width, appeared not to support permanent squirrel populations, although light feeding signs were present. Signs of squirrel feeding were not present in the narrow SMZ. Gray and fox squirrels were equally abundant. Only gray squirrels were observed in one wide SMZ and fox squirrels were predominant in the other. One fox squirrel was seen in the medium SMZ.

Primary results from the early phase of this study will be published after the second year of data collection.

## LITERATURE CITED

- Bouffard, S. H., and D. Hein. 1978. Census methods for eastern gray squirrels. *J. Wildl. Manage.* 42:550-557.
- Dickson, J. G. 1978. Forest bird communities of the bottomland hardwoods. Pages 66-73 in R.M. DeGraaf, Tech. Coor., Proc. workshop on management of southern forests for nongame birds. USDA For. Serv. Gen. Tech. Rep. SE-14. Atlanta, GA.
- McElfresh, R. W., J. M. Inglis, and B. A. Brown. 1980. Gray squirrel usage of hardwood ravines within pine plantations. *La. State Univ. Ann. For. Symp.* 19:79-89.
- Stauffer, D. E., and L. B. Best. 1980. Habitat selection by birds of riparian communities: evaluating effects of habitat alterations. *J. Wildl. Manage.* 44:1-15.
- Stransky, J. J., and L. K. Halls. 1968. Woodland management trends that affect game in coastal plain forest types. *Proc. Ann. Conf. Southeast. Assoc. Game and Fish Comm.* 21:104-108.
- Warren, R. C., and G. A. Hurst. 1980. Squirrel densities in pine-hardwood forests and streamside management zones. *Proc. Ann. Conf. Southeast. Assoc. Fish and Wildl. Agencies.* 34:492-498.

# Development and Management of Riparian Wildlife Habitat by the Tennessee Valley Authority<sup>1</sup>

Ronald J. Field and Roosevelt T. Allen<sup>2</sup>

---

The Tennessee Valley Authority is responsible for management of 11,200 miles of riverine or lacustrine shoreline in portions of seven States. The agency has undertaken numerous projects including wetlands enhancement, manipulation of dewatering units, agricultural license restrictions, and drawdown zone seeding, to improve these areas for wildlife populations.

---

The Tennessee River system transects portions of the seven southeastern States of Virginia, North Carolina, Kentucky, Tennessee, Georgia, Alabama, and Mississippi. Its major tributaries, the Holston and French Broad, begin in mountainous southwestern Virginia and North Carolina and fall from 2600 feet to 1000 feet msl from the headwaters to their confluence at Knoxville where they form the Tennessee. From there the river flows 650 miles to its junction with the Ohio River in Paducah, Kentucky, at a final elevation of 300 feet msl. Historically the Tennessee was an undeveloped resource which defied navigation because of abrupt fluctuations in gradient, and several hazardous shoal areas as shallow as 18 inches. The river seasonally ravaged the Valley with floodwaters, scouring erosive top soils from poorly managed farms to deposit them in bottomlands further downstream (McCarthy & Voightlander 1983).

In 1933 legislation known as the Tennessee Valley Authority Act was introduced by Senator George Norris of Nebraska and signed into law by President Franklin D. Roosevelt. The Act directed the Tennessee Valley Authority to provide flood control, navigation, electrical power production, fertilizer development, reforestation, agricultural and industrial development, and to "aid further the proper use, conservation, and development of the natural resources of the Tennessee River drainage basin" (TVA Act of 1933).

TVA operates across an 80,000 square mile, 201-county region. The nine mainstream reservoir and 23 tributary dam projects inundate 654,000 acres at full summer pool, creating

---

<sup>1</sup> Paper presented at the Riparian Ecosystems and their Management: Reconciling Conflicting Uses Conference. [University of Arizona, Tucson, April, 16-18, 1985].

<sup>2</sup> R. J. Field is Program Manager of Wildlife Resources Development, TVA, Norris, Tenn.; R. T. Allen, Divisional Environmental Coordinator, TVA, Knoxville, Tenn.

11,280 miles of lacustrine and riverine shoreline (TVA 1984). Much of this land conforms to the definition of riparian zone used by Thomas et al. (1979). For uniformity, areas adjacent to both impounded and freeflowing water will be considered riparian for this paper.

The Office of Natural Resources and Economic Development is responsible for providing environmental safeguards and enhancement of environmental quality within the riparian zones of the 346,000-acre area owned by TVA above normal full pool level, as well as the 176,000 acres of shoreline subject to annual flooding and drawdown (Fowler & Maddox 1974). These activities are conducted through a series of Federal laws, executive orders, and agency promulgated policies and practices designed for environmental protection, and through programmatic projects designed to develop or enhance natural resources in the Tennessee Valley. These activities have been previously discussed during this conference (Allen and Field, 1985).

## ENHANCEMENT OF RIPARIAN ZONES FOR WILDLIFE

Because of the agency's role in conservation and development of natural resources, TVA has, for many years, been involved in the management of riparian zones for numerous purposes. Development of wildlife habitat in these areas is an integral part of this role.

### Dewatering Areas Management

Early in the history of TVA, biologists in the Biological Readjustment Unit attempted to evaluate how the conversion of the Tennessee River into a chain of lakes affected water-related wildlife (Cahn 1938) and how forestry and agriculture would affect upland species (TVA 1946). One of the first major efforts to manage riparian zones occurred in conjunction with establishment of Kentucky Reservoir by constructing several miles of low dikes and levees along the river. On Wheeler Reservoir, similar structures were built

after impoundment (Weibe & Hess 1944). They were equipped with water control gates and massive pumps with up to 52,000 gallon per minute water movement capacity. The pumps were designed to remove the shallow, impounded water from areas behind these dikes during the spring and summer seasons. Through this dewatering process breeding habitat for the malaria vectoring Anopheles quadrimaculatus mosquito was eliminated. Eight of the dewatering units began operation during 1945, and two in 1949. The seasonal dewatering of slightly more than 13,000 acres of fertile bottomlands not only eliminated mosquito breeding areas, it enabled extensive production of agricultural crops and native moist soil plants such as smartweeds and millets (Weibe et al., 1950). Several thousand acres of lands in the units were licensed or transferred to the States or what is now the U.S. Fish and Wildlife Service, for the management of waterfowl and other wildlife. These units subsequently became a principal factor, in combination with the deteriorating wetlands habitat along the Gulf Coast, in establishing the Tennessee River Valley as a major wintering area for more than 1/2 million waterfowl annually, on an area that had formally held fewer than 10,000 birds. By 1962, 68 percent of the wintering waterfowl in the States of Tennessee and Alabama were located within the Tennessee Valley (TVA 1962).

A combination of factors, including design of a detailed forest inventory procedure on TVA lands (Field et al, 1985) and record high spring water levels in 1983 and 1984, resulted in close scrutiny of the more than 3,000 acres of bottomland hardwoods in the dewatering areas. Several stands of timber were found to exhibit uneven symptoms of water induced stress. Efforts were quickly initiated to evaluate the extent of the problem and attempt to identify the source. A combination of techniques, including the use of high altitude color infrared photography, elevation surveys, and onsite vegetation analysis and inventory described elsewhere (Fowler et al., 1985), was used.

This investigation resulted in the diagnosis of a major problem within three of the ten dewatering units. Increasing populations of beavers within the units had combined with siltation in several drainage ditches or canals, to effectively prevent removal of water from the seasonally flooded timber during the spring. This inundation during the growing season had caused tree mortality in several areas, and as the dead trees fell across drainage ditches, the problem was exacerbated. The magnitude of the situation required an extensive program of debris and silt removal to restore water management capability, which resulted in approximately 62 miles of ditch and levee renovation, at a cost of approximately \$1.4 million. Fortunately, the initiation of this project coincided with passage of the 1983 Federal Jobs Bill (Public Law 98-8), and a large number of previously unemployed workers were hired to execute the renovation with minimum environmental disturbance. Following guidelines published by the International Association of Fish and Wildlife Agencies (McConnell et al., 1983), hand clearing operations, small tractors

with backhoes, and some heavy equipment using draglines were used to remove obstructing materials from clogged ditches and repair eroded dikes. Helicopters were used to reseed spoil banks. Some timber salvage has been conducted to utilize standing timber before further deterioration occurs. Experiments are presently underway for reestablishing important bottomland hardwood stands in many areas where water damage has resulted in the loss or removal of these species.

#### Drawdown Zone Management

The dewatering units located on Kentucky and Wheeler Reservoirs are readily accessible to waterfowl migrating along the Mississippi Flyway. The majority of the Tennessee River and its major tributaries, the Holston, French Broad, Clinch, and Little Tennessee, however, lie between the Mississippi and the Atlantic flyways. Their geographic location in the mountainous terrain of Virginia and North Carolina, combined with their major functions in flood storage and power production, long ago were identified as major impediments to effective management of wildlife on these upper reservoirs (Weibe 1946). The drawdown zone for flood water storage on tributary reservoirs may exceed 100 feet in some cases, making natural growth and maintenance of either emergent or submergent aquatic plants nearly impossible during the fall migrating and wintering periods for waterfowl. Consequently little food is present and few waterfowl use the region, even though Bellrose (1976) estimates that up to 3/4 million waterfowl overfly these areas during annual migrations.

Several techniques have been successfully employed to address this situation for the benefit of waterfowl and upland species. Fowler and Whelan (1980) clearly showed the value of drawdown zone seeding for deer on TVA reservoirs. Earlier work by Fowler and Maddox (1974) and Fowler and Hammer (1976) identified effective techniques for applying seed and fertilizer to both mudflats and steep shorelines along reservoirs, using a barge mounted hydroseeder or aquaseeder, an air cushion vehicle, and a helicopter. Each exhibited some advantages under specific conditions.

In 1982 TVA initiated a program on Douglas Reservoir to establish suitable habitat and food for migrating waterfowl. Initially the project involved the hand clearing of woody vegetation and use of a rice terrace plow to temporarily retain standing water after the summer reservoir drawdown. Areas adjacent to the temporary sub-impoundment were seeded with a mixture of Japanese millet and buckwheat in order to provide adequate food for incoming birds. Portable pumps were used to pump water up from the reservoir to flood the sites.

Initial efforts in the 740-acre area were moderately successful and encouraging. Although unusually dry weather and porous soil inhibited water retention, informal surveys suggested increased use of the area by both migrant waterfowl and deer. Efforts were consequently expanded and

sand bags were used to build low dikes in runoff areas, thus creating 12 shallow ponds or sloughs ranging in size from 1/10 to 4 acres. These areas contained large quantities of natural moist site vegetation, which was supplemented with seeded cereal crops. Surveys during September 1984 indicated several thousand shore and wading birds, including great egrets, white ibises, and herons; 900-1000 wood ducks, and large numbers of teal, mallards, and Canada geese, made extensive use of the area. A major increase in white-tailed deer use of the project area also occurred, which was attributed to availability of natural and domestic food plants. A total of 22 deer were legally harvested from the 740-acre area in 1984, the first year of open hunting on the site.

#### Nolichucky Project

A major project on one of the second order tributaries of the Tennessee is TVA's Nolichucky Waterfowl Sanctuary and Environmental Study Area in east Tennessee. The Nolichucky Dam, built in 1913 as a small hydroelectric project, initially impounded some 21,750 acre feet of water covering approximately 635 surface acres (TVA, 1972). Mica and feldspar mining operations in the North Carolina watershed, however, caused extensive siltation in the reservoir, gradually reducing storage capacity. By 1970 less than 25 percent of this storage remained, and by 1980, 90 percent had been eliminated. In 1972, TVA retired the facility and designated the 1,000-acre project as a waterfowl sanctuary and environmental study area. Water levels were manipulated using a 2-foot scheduled drawdown to seasonally expose 70 acres of mudflats. These areas were seeded to millet, buckwheat, sorghum, and other cereals, and reflooded during the fall and winter for migrating waterfowl. The mudflats also supported numerous native species including smartweeds and sedges. Concomitantly, upland areas adjacent to the reservoir were planted to hedgerows of autumn olive, sawtooth oak, and bicolor lespedeza, and nest boxes were built and placed for bluebirds, wood ducks, and other species. The result has been an influx of breeding wood ducks, with 1983 nighttime float counts as high as 3.5 broods and 38 birds per mile of impounded water, and wintering waterfowl counts ranging between 2,000 and 3,000 birds.

#### Agricultural Practices

Nearly 20,000 acres of TVA's reservoir lands are licensed to local farmers for hay/pasture or row crop production. In many areas soils are highly erosive and most are subject to irregular inundation during periods of unusually high water. Poor farming practices, historically a problem in the Tennessee Valley, have sometimes been employed on these licensed lands, resulting in soil erosion and decreased water quality in adjacent reservoirs. Consequently in 1982, TVA implemented a program designed to curtail riparian zone erosion and simultaneously enhance lands under agricultural license for wildlife. A policy was established which required that each tract of land subject to

row crop licensing, be reviewed by a wildlife biologist. In tracts of sufficient size, configuration, or placement to be important, special requirements such as buffer strips of unmowed natural vegetation adjacent to the reservoir, maintenance of ditches or gullies in native vegetation, or leaving a percentage of grain crops for wildlife use, are incorporated within the license agreement. Agency lands licensed for livestock pasturage are also being reviewed to determine whether rest-rotation grazing schemes (Kauffman and Krueger 1984) may be practical on these areas.

#### Other Projects

Numerous other less conspicuous but very important projects have been established on TVA's riparian lands for the benefit of wildlife. These include Valley-wide wood duck habitat evaluation and cooperative wetlands mapping with the U.S. Fish and Wildlife Service in the National Wetlands Inventory program.

Another important action has been the establishment of two eagle sanctuaries covering approximately 1000 acres of land and water surface on TVA's Land Between The Lakes (LBL). These sanctuaries were established in 1974 and 1981 to secure an area frequented by relatively large numbers of wintering bald and golden eagles. An average of 50 eagles, at times ranging as high as 85, winter on the 170,000 LBL area and a communal roost has been documented within one of the sanctuary areas.

Establishment of these sanctuaries has been an integral aspect of TVA's raptor restoration and management projects. These include a cooperative bald eagle restoration effort involving State, other Federal agencies, and private conservation organizations which have resulted in the release through hacking of 12 young and 2 rehabilitated adult bald eagles at LBL since 1980, and an additional 8 bald, 24 golden eagles, 131 ospreys, and 8 peregrine falcons at other sites. This project resulted during 1984 in the first successful nesting of a captive reared bald eagle in the wild (Hammer et al., 1984).

#### CONCLUSION

TVA has been active in the management of riparian lands under its ownership since its inception in 1933. Many of the techniques that have been used have involved innovative approaches to management of vegetation, and consequently wildlife, in conjunction with water level manipulations. Other efforts have concentrated on protection of riparian habitat. Additional techniques including comprehensive land use planning and compartmental forest management have been discussed elsewhere (Field et al., 1985) and blend well with the overall conservation and development responsibility of the Tennessee Valley Authority. These techniques, and others yet to be developed, contribute to the maintenance of environmental quality in the Tennessee River Valley.

## LITERATURE CITED

- Allen, R. T., and R. J. Field. 1985. Riparian Zone Protection by TVA: An Overview of Policies and Programs. Proc. of 1985 Riparian Ecosystem Management Conference (In Press).
- Bellrose, Frank C., 1976. Ducks, Geese and Swans of North America. A Wildlife Management Institute Book sponsored jointly with the Illinois Natural History Survey. Stackpole Books. Harrisburg, PA. 544 pp.
- Cahn, A. R., 1938. The work of the TVA in relation to the wildlife resources of the Tennessee Valley. Jl. of the Tenn. Acad. of Sci. 13(3):174-179.
- Field, R. J., D. C. Forbes, and L. M. Doyle, 1985. Multiple-use management on Tennessee Valley Authority lands. Trans. 50th North Am. Wildlife and Nat. Res. Conf. (In Press).
- Fowler, D. K. and J. B. Maddox, 1974. Habitat improvement along reservoir inundation zones by barge hydroseeding. Jl. Soil & Water Cons. 29(6):263-265.
- Fowler, D. K. and D. A. Hammer, 1976. Techniques for establishing vegetation on reservoir inundation zones. Jl. Soil & Water Cons. 31(3):116-118.
- Fowler, D. K. and J. B. Whelan, 1980. Importance of inundation zone vegetation to white-tailed deer. Jl. of Soil & Water Cons. 35(1):30-33.
- Fowler, D. K., W. K. James, and D. Becker, 1985. Use of infra-red photography to identify bottomland hardwood stands damaged by standing water. Presentation at 1985 Soil Cons. Soc. of Amer. annual meeting (In preparation).
- Hammer, D. A., J. L. Mechler, M. E. Cope, and R. L. Lowe, 1984. Successful wild nesting of a three-year old captive reared bald eagle (Abstract). Raptor Research Foundation annual meeting, Blacksburg, VA.
- Kauffman, J. B. and W. C. Kreuger, 1984. Live-stock impacts on riparian ecosystems and streamside management implications. . . a review. Jl. Range Management 37(5):430-437.
- McCarthy, D. M. and C. W. Voightlander, Editors, 1983. The first fifty years: changed land, changed lives. State-of-the-environment in the Tennessee Valley--1983. Tennessee Valley Authority, Knoxville, TN. 212 pp.
- McConnell, C., A. Burns, E. Claire, D. Huff, J. Karr, G. Montgomery, D. Parsons, J. Sedell, and M. Seehorn, 1983. Stream obstruction removal guidelines. International Assoc. of Fish & Wildlife Agencies, The Wildlife Society, and The Am. Fisheries Soc., Bethesda, MD. 10 pp.
- Tennessee Valley Authority Act (PL 48-58, 18 May 1933).
- Tennessee Valley Authority 1946. Biological Readjustment Division. Annual report, fiscal year 1946. Rept. 190-46. Norris, TN.
- Tennessee Valley Authority 1962. Annual report FY 1962. Division of Forestry Development. Norris, TN.
- Tennessee Valley Authority, 1972. Environmental Statement: Rehabilitation of Nolichucky Project. TVA-OHES-EIS-72-2. Chattanooga, TN. 17 pp & appendix.
- Tennessee Valley Authority. 1984. TVA Handbook. Knoxville, Tennessee. 261 pp.
- Thomas, J. W., C. Maser, and J. E. Rodiek. 1979. Wildlife Habitats in Managed Rangelands--The Great Basin of Southeastern Oregon. Riparian Zones. USDA Forest Service General Technical Report PNW-80. 18 pp.
- Weibe, A. H. 1946. Improving Conditions for Migratory Waterfowl on TVA Impoundments. Jl. Wildlife Mgt. 10(1):4-8.
- Weibe, A. H. and A. D. Hess, 1944. Mutual interests of wildlife conservation and malaria control on impounded waters. Jl. Wildlife Mgmt. 8(4):275-283.
- Weibe, A. H., E. R. Cady and P. Bryan, 1950. Waterfowl on the Tennessee River impoundments. Trans. 15th North Am. Wildlife Conf. 15:111-117.



# Responses of Small Mammals to Forest Riparian Perturbations<sup>1</sup>

Stephen P. Cross<sup>2</sup>

---

Abstract.--Trapping studies at several mixed conifer forest sites in southwestern Oregon demonstrate a differentially high use of riparian habitat by small mammals. Harsh perturbations of this habitat radically affect the presence and abundance of many species. Riparian leave-strips were found to support small-mammal communities comparable to undisturbed sites.

---

## INTRODUCTION

Riparian areas have been identified as extremely important habitat for wildlife (Johnson and Jones 1977, Thomas et al. 1979). Much of the supporting data for this contention comes from studies in arid regions where the riparian vegetation contrasts sharply with other types and is the only local source of some essential habitat components such as trees and free water. The riparian zone in more mesic regions, although recognizable, does not contrast as sharply with nearby habitats. Trees are not so limited in distribution and free water is generally more widely available and in less demand by wildlife. Considering these conditions, it is appropriate to ask if there is disproportionately high use of the riparian zone by wildlife in mesic regions.

Natural history information suggests that more wildlife species potentially use forest riparian habitat than other nearby habitats. But quantitative assessments of species diversity and abundance are necessary to verify the predicted differential or disproportionate use.

Streamside forest riparian vegetation is usually distinct from nearby upland vegetation which is upslope and not under direct influence of the stream. The blending of riparian and upland vegetation often creates a rather broad and distinctive ecotone, usually referred to as the transition zone. This zone is particularly important because of its potentially high value for timber production, wildlife habitat, and as a buffer for the riparian zone.

Clearcutting and other harsh forest perturbations are known to have a profound effect

on some small-mammal species (Gashwiler 1970, Black and Hooven 1974, Hooven and Black 1976, Campbell and Clark 1980). But little attention has been given to comparing the effects of such perturbations on wildlife such as small mammals of different forest vegetational zones. Leaving a strip (buffer) of riparian and transition zone vegetation along the edges of streams when the surrounding area is logged is a forest management practice used in some areas. There are many potential benefits to this practice but the effects on resident wildlife populations of the streamside leave-strip are not known.

The studies reported here were designed to make quantitative comparisons of the small-mammal use of various forest vegetation zones associated with streams. A related objective was to assess the impact of harsh forest perturbations and riparian leave-strips on the resident small-mammal communities.

## GENERAL STUDY AREA AND METHODS

The studies were conducted at four sites in southwestern Oregon in the mixed-conifer vegetation zone (Franklin and Dyrness 1973). The study sites were widely separated and varied in vegetational composition.

Small mammals were collected using three types of traps. Sherman live-traps (9 x 7.5 x 23.5 cm) and pitfall traps (5-lb plastic food container, 18.4-cm deep with 14.6-cm diameter opening) were used at all the sites. Museum Special snap traps were used at two of the sites. Bait consisted of rolled oats for the live-traps and a mixture of rolled oats and peanut butter for the snap traps. After all traps were in place at a given site there was a 4-5 day waiting period before they were activated. During this period the pitfall traps were covered with tight fitting lids and the other traps were prebaited. Once traps were activated they were checked twice daily, during the 3-4 hours after sunrise and the 2-3 hours before dark.

---

<sup>1</sup>Paper presented at the North American Riparian Conference. [University of Arizona, Tucson, April 16-18, 1985].

<sup>2</sup>Stephen P. Cross is a Professor of Biology, Department of Biology, Southern Oregon State College, Ashland, Oregon.

Small mammals trapped alive were identified, sexed and aged when possible, and toe-clipped for individual identification. Emphasis was placed on live-trapping to minimize any increase in immigration that might be caused by removal and to study the influence of streams on local movements.

Data from each sample plot were placed in contingency tables and analyzed with the chi-square statistic. Since small-mammal trapping is somewhat selective and may not accurately reflect the true community structure, the Brillouin index (log to base 2) was used as a measure of diversity. Two quantitative values for similarity, the quotient of similarity and percent similarity, were used to compare small-mammal samples from various habitats or test plots. The former takes into account only the presence or absence of species, whereas the latter also takes into account the relative abundances of the various species. Derivation and use of the above quantitative measures are described in Brower and Zar (1984).

#### DIFFERENTIAL USE OF RIPARIAN HABITAT - SODA CREEK

The specific objective of this study was to compare small-mammal abundance, community composition, and diversity in a coniferous forest streamside riparian zone with neighboring habitats.

#### Study Site and Methods

The Soda Creek study site is located in an old-growth forest in the foothills of the southern Oregon Cascades, 23-km northeast of Ashland, T37S, R3E, Sections 19 and 20, Willamette Meridian at ca. 900-m elevation. The creek flows northerly into the south fork of Little Butte Creek, part of the Rogue River drainage. Although relatively small (streambed ca. 5-m), the creek influences the surrounding vegetation to the extent that three typical zones (i.e. habitats) may be recognized.

The riparian zone is dominated by Douglas-fir (*Pseudotsuga menziesii*), bigleaf maple (*Acer macrophyllum*), white alder (*Alnus rhombifolia*), and western redcedar (*Thuja plicata*) in the canopy and understory. Shrub species in the understory include California hazel (*Corylus cornuta*), ocean spray (*Holodiscus discolor*), and ninebark (*Physocarpus capitatus*). Thirty species of ground cover plants were identified with mosses, bedstraw (*Galium* sp.), thimbleberry (*Rubus parviflorus*), snowberry (*Symphoricarpos albus*), and grasses occurring most frequently.

The upland zone has a canopy and understory also dominated by Douglas-fir with some western redcedar and Pacific madrone (*Arbutus menziesii*), and occasional Ponderosa pine (*Pinus ponderosa*) and California black oak (*Quercus kelloggii*). There are very few shrubs present. Twenty-two species of ground cover were identified but most ground is devoid of cover.

The transition zone, located between the riparian and upland zones, includes a distinctive combination of vegetative characteristics of the other two zones. This area is dominated by Douglas-fir in the canopy to a greater extent than the other zones. There are some western redcedar, bigleaf maple, and grand fir (*Abies grandis*) also present. Twenty-five species of ground cover were recorded with whipple vine (*Whipplea modesta*), twinflower (*Linnaea borealis*), mosses, snowberry, and grasses being the most abundant. Widths of the riparian and transition zones are somewhat variable depending upon slope and aspect.

Small-mammal communities in each of the zones were sampled in the following manner. Two-row belt transects were placed parallel to the stream in each vegetative zone. Each row consisted of 20 stations divided into two separate 10-station sections. The resulting pattern had 40 stations in each zone in the form of two replicate 20-station belt transects. The two rows of each transect were 12.5-m apart while the distance between stations within a row was 15-m. The two 20-station transects within each zone were offset from those of the other zones to avoid interference. The riparian transect was positioned so that the two rows of traps were on opposite sides of the stream. This was done in order to stay within the relatively narrow zone of riparian vegetation and to allow mammals utilizing this zone equal exposure to both rows of traps, as in the other zones.

Two Sherman live-traps and one pitfall trap were placed within 2.5-m of the station marker. The live-traps were placed on opposite sides of the station marker and moved roughly 90° after each two days of trapping. The traps were activated on 23 June 1981 and remained in operation for 10 days (9 nights). Total trap-days (nights) were identical for each zone.

#### Results and Discussion

Since the small-mammal samples from the replicate transects within each of the three habitat zones were not significantly different ( $p > 0.05$ ) they were combined for further analysis. The species captured and the associated measures of abundance and diversity within each habitat zone are shown in table 1. The species frequencies in the samples from the three zones are significantly different ( $p < 0.001$ ). Pairwise comparisons of the samples indicate that the riparian is significantly different from both the transition ( $p < 0.001$ ) and upland ( $p < 0.001$ ) but the transition is not significantly different from the upland ( $p > 0.05$ ). Sample size, an indication of abundance, is similar in the riparian and transition zones (106 and 102, respectively), almost double that of the upland zone (54).

Species richness is greatest in the sample from the riparian zone, intermediate in the transition zone, and lowest in the upland zone. The computed diversity indices follow the same trend. All the species captured in either the upland or transition habitats are also present in

Table 1.--Small-mammal species abundance and diversity in three habitat zones adjacent to Soda Creek.

Species and Summary	Habitat Zone		
	Riparian	Transition	Upland
Deer mouse	23	14	13
California red-backed vole	24	35	18
Trowbridge's shrew	25	43	23
Pacific shrew	13	3	0
Shrew-mole	13	7	0
Jumping mouse	6	0	0
Siskiyou chipmunk	1	0	0
Vole species	1	0	0
Total species	8	5	3
Total individuals	106	102	54
Diversity (H)	2.39	1.75	1.44
Evenness (J)	.8524	.7976	.9763

the riparian zone sample. Conversely, five of the species captured in the riparian zone are absent in the samples from one or both of the other zones. The riparian zone sample has the highest number of individuals for six species while the transition zone has the highest number of individuals for two species.

The quotient of similarity (table 2), based only on species composition, indicates that the riparian and upland samples are less similar to each other than the other combinations. But when the number of each species is also considered, as in percent similarity, the transition and upland zones are more similar to one another than the other combinations, which agrees with the chi-square analysis.

These data indicate differential occupancy patterns in the three habitats sampled. The Soda Creek riparian zone appears to support a more diverse small-mammal fauna than the adjacent forested habitats. Most species also occur in greater abundance in this habitat, but a high number of two species in the transition zone makes it comparable in total abundance to the riparian zone.

Table 2.--Community comparisons of small mammals in the three zones adjacent to Soda Creek (R = riparian, T = transition, U = upland).

Characteristic	Habitats Compared		
	R x T	R x U	T x U
Total species	8	8	5
Species in both	5	3	3
Quotient of similarity	.769	.545	.750
Percent similarity	69.8	67.9	89.2

DIFFERENTIAL USE AND HARSH PERTURBATION - LOUIS CREEK

The first objective of this study was identical to that described for Soda Creek. Another objective was to compare the small mammals from the riparian and upland zones in an old-growth coniferous forest to similar locations in a neighboring clearcut.

Study Area and Methods

The Louis Creek study site is located on the western flank of the Cascade Mountains, ca. 470-m elevation, 17.7-km northeast of Myrtle Creek, T28S, R3W, sections 29 (forest) and 30 (clearcut), Willamette Meridian. Louis Creek flows southeasterly into South Myrtle Creek, part of the Umpqua River drainage. The creek is quite small (streambed ca. 2-m) and the associated open (non-canopied) corridor is also small, but a riparian zone along the edges of the creek can be recognized. The transition and upland zones are also recognizable although the edges are not as clearly defined as in the more xerically situated Soda Creek site.

The three vegetation zones may be distinguished on the basis of the combinations of dominant canopy and understory. The riparian zone is characterized by a canopy dominated by western hemlock (Tsuga heterophylla) with some representation of western redcedar, Pacific yew (Taxus brevifolia), and grand fir. The understory of this zone is dominated by vine maple (Acer circinatum) with some Pacific dogwood (Cornus nuttallii). A few red alder (Alnus rubra) are unique to this zone. The transition zone canopy is also dominated by western hemlock followed by western redcedar, grand fir, and Douglas-fir. The understory is again dominated by vine maple but also includes California hazel (Corylus cornuta) and western hemlock. A few bigleaf maple occur in both the riparian and transition zones. The upland zone canopy is dominated by grand fir and Douglas-fir with western hemlock scarcely represented. The understory is dominated by incense cedar (Libocedrus decurrens) and saplings of Douglas-fir and grand fir.

Riparian zone ground cover has the highest density and the greatest number of unique species. The upland zone ground cover has lower density and few unique plant species while the transition zone has moderate density and virtually no unique species.

A clearcut, located to the immediate west of the forest study area was used for another study plot. The site was logged, prepared and replanted during the summer and fall of 1977. It was sprayed with herbicides each year from 1978 through 1981 to reduce competition with conifer seedlings.

The trap transect pattern for sampling small mammals in the forest was similar to the one used at Soda Creek. The interstation distance was 10-m between rows and 12-m within each row. Two

additional transects, similar in relative location and interstation distances to the riparian and upland zones in the forest, were placed in the clearcut. Trapping regimen was identical to Soda Creek. Trapping began on 18 August and was completed on 28 August 1981.

### Results and Discussion

The frequencies of small mammal captures from the replicate transects within each of the habitat zones of both the forest and the clearcut were not significantly different ( $p > 0.05$ ) so those samples were pooled. The capture frequencies, total individual captures, and sample diversity are shown in table 3. Within the forest, the capture frequencies of the samples from the three habitat zones are significantly different ( $p < 0.001$ ). Also, when the samples from the habitat zones are compared in a pairwise fashion, they are significantly different ( $p < 0.01$ ).

Sample size indicates that small mammals are somewhat more abundant in the forest riparian zone than in the other two forest zones. Species richness is highest in the riparian and transition zone samples. The diversity indices grade from highest in the riparian to lowest in the upland. The greatest similarity of species occurs between the riparian and transition zones (table 4). When numbers of each species are also considered, as in percent similarity, it is evident that the riparian and upland zones are the least similar.

Frequencies of small mammals in samples from the two zones of the clearcut are also significantly different ( $p < 0.001$ ). Species richness, abundance, and diversity are highest in the riparian zone sample. Although 10 species were captured in the clearcut, only five of them were found in both zones, producing a relatively

low quotient of similarity (table 4). But when the numbers of each species are also considered, the two zones show a relatively high percent similarity, a reflection of the equally high numbers of three species.

The frequencies of small mammals in the samples from the riparian zone of the forest and the clearcut are significantly different ( $p < 0.001$ ). This is also true for the upland region of the forest and the clearcut. Species richness and other measures of diversity are higher for the forest riparian than in the clearcut riparian samples. But sample size, an indication of density, is greater in the clearcut. To a lesser degree, this also holds true for the forest and clearcut upland samples but they are comparable in richness and other measures of diversity. Species composition within a given zone is quite different (tables 3 and 4) in the forest and clearcut samples. Only six of 12 species occurred in both riparian zones and only four of 10 occurred in both upland zones. This results in relatively low quotients of similarity. The percent similarity, however, indicates that the respective riparian zones of the forest and clearcut are more similar to one another than the riparian and upland zone of the forest. The composition and frequencies of species from the upland zone of the forest and clearcut are very dissimilar.

Individual species patterns in the three Louis Creek forest habitat zones are similar to those observed at Soda Creek. The jumping mouse (*Zapus* sp.) is almost completely restricted to the riparian habitat in both forests. Other species, such as the northern flying squirrel (*Glaucomys sabrinus*) and shrew-mole (*Neurotrichus gibbsii*), show preference tendencies for the conditions found in the riparian zone. The marsh shrew (*Sorex bendirii*) is represented by only one capture in the riparian zone at Louis Creek but,

Table 3.--Small-mammal species abundance and diversity in three habitat zones adjacent to Louis Creek.

Species and Summary	Forest			Clearcut	
	Riparian	Transition	Upland	Riparian	Upland
Deer Mouse	18	20	9	56	50
California red-backed vole	11	25	31	0	0
Trowbridge's shrew	26	19	33	24	19
Pacific shrew	16	12	6	10	0
Townsend's chipmunk	8	3	11	8	6
Pacific jumping mouse	25	1	0	36	0
Creeping vole	3	3	1	39	37
Northern flying squirrel	3	1	1	0	0
Shrew-mole	1	1	0	0	0
Other (2 species)	1	1	0	0	0
California ground squirrel	0	0	0	5	4
Dusky-footed woodrat	0	0	0	0	8
Other (2 species)	0	0	0	2	1
Total species	10	10	7	8	7
Total individuals	112	86	92	180	125
Diversity (H)	2.60	2.30	1.99	2.39	2.10
Evenness (J)	.841	.757	.763	.831	.758

Table 4.--Community comparisons of small mammals in the various habitat zones at Louis Creek (R = riparian, T = transition, U = upland, ClC = clearcut, For = forest).

Characteristic	Areas and Habitats Compared					
	Forest			Clearcut	For x ClC	
	R x T	R x U	T x U	R x U	R	U
Total species	11	10	10	10	12	10
Species in both	9	7	7	5	6	4
Quotient of similarity	.900	.824	.824	.667	.667	.571
Percent similarity	71.3	58.7	73.1	73.3	63.9	30.9

based on life history information (Maser et al. 1981), it is likely to be restricted to that zone. With the exception of one individual of one species, a mole (Scapanus sp.), all species that were sampled in the transition and upland zones were also sampled in the riparian zones. This finding is important when considering the relative value of the different zones as travel corridors or permanent living space.

Clearcutting and the other associated harsh perturbations had some striking affects on the zonally associated small-mammal communities. Some species, such as the deer mouse (Peromyscus maniculatus) and creeping vole (Microtus oregoni), appear to be more abundant in both the riparian and upland zones of the clearcut than in the forest. The jumping mouse also occur in larger numbers in the riparian zone of the clearcut than in the forest. Some species, such as the California ground squirrel (Spermophilus beecheyi), dusky-footed woodrat (Neotoma fuscipes), Townsend's vole (Microtus townsendii), and house mouse (Mus musculus) occur only in the clearcut samples. Effects on other species, such as Townsend's chipmunk (Eutamias townsendii) and Trowbridge's shrew (Sorex trowbridgii) seem to be minimal.

A species very closely tied to the riparian zone of the forest, the Pacific jumping mouse, was not lost in the clearcut. Other species, such as the California red-backed vole (Clethrionomys californicus), northern flying squirrel, shrew-mole, and three others that occur in the forest, were not found in the clearcut. The Pacific shrew (Sorex pacificus), found in all three zones of the forest, is only present in the riparian zone sample from the clearcut.

These findings suggest that the majority of small mammals residing in mixed-conifer communities in southwestern Oregon are capable of living in the riparian zone. Some species survive even when this zone is harshly perturbed, while others are exterminated or have populations reduced. Riparian leave-strips or buffers have been suggested as a means of mitigating losses and providing connections between forest habitat islands.

#### EFFECT OF A RIPARIAN LEAVE-STRIP - MIDDLE AND SOURGRASS CREEKS

The objective of these studies was to assess the effect of leaving a strip of forest riparian and transition vegetation, when the neighboring area is harshly perturbed, on the resident small-mammal community.

#### Study Area and Methods

##### Middle Creek

The Middle Creek study site is located in the Klamath Mountains, ca. 12.5-km west of Glendale, T31S, R7W, Section 25, Willamette Meridian at ca. 457-m elevation. This moderate-sized (streambed ca. 6-m) creek flows westerly into Cow Creek, part of the Umpqua River drainage.

The local forest is dominated by Douglas-fir and grand fir. Oregon ash (Fraxinus latifolia), vine maple, and red alder are abundant in the riparian zone. Salal (Gaultheria shallon) is a common groundcover. Since this is a comparison study of two similarly vegetated sites, a description of other distinctive zonal characteristics is unnecessary.

Two plots were used for study. The upstream (full-forest) plot is largely undisturbed old-growth forest with attendant vegetative zones on the south side of the stream. The north side of the stream is variously disturbed, with a dirt road running parallel to it about 25-m away. The downstream (leave-strip) plot, located approximately .5-km to the west, is essentially a streamside strip or corridor of forest vegetation. The north side of the strip is formed by the road described above and the south side is bordered by another road on the edge of a clearcut plantation containing ponderosa pine saplings. The major difference between the two plots is that the south side of the full-forest plot blends into upland forest whereas the south side of the leave-strip plot is an abrupt forest edge bordered by a road and clearcut. The small-mammal samples from both sites were collected from the south side of the creek in the riparian and transition vegetation zones. The average width of the leave-strip on the south side of the experimental site is 67-m.

Two parallel rows of 20 stations, with 10-m spacing, were placed 5-m and 15-m, respectively, from the south edge of the creek in each plot. One live-trap, one snap trap, and one pitfall trap partially filled with water were placed within 2.5-m of each station marker. Traps were tended for ten consecutive days, 7-16 July 1980.

#### Sourgrass Creek

Sourgrass Creek is located in the Klamath Mountains, approximately 12.9-km west of Galice. It is a relatively small (streambed ca. 3-m) stream which flows into Silver Creek, a tributary of the Illinois River. The study sites were located in T35S, R9W, sections 2 and 3, Willamette Meridian at ca. 1050-m elevation.

Vegetatively, the general area is dominated by Douglas-fir and western hemlock in the overstory and Port-Orford-cedar (*Chamaecyparis lawsoniana*) and grand fir in the understory. Western azalea (*Rhododendron occidentale*) and salal are common ground cover. The riparian zone is narrow but distinguishable by some unique vegetation, including red alder in the understory. The vegetation was judged to be similar in the various study plots.

Four streamside plots were used for study. These plots are designated A to D from upstream to downstream. Plots A and D were in relatively undisturbed forest. Plots B and C were streamside leave-strips resulting from recent (one year old) clearcuts on one side of the creek and a road and partial cutting on the other. Plot B had leave-strips approximately 9-m wide on the clearcut side and slightly larger and more variable on the road side. Plot C had a leave-strip approximately 12-m wide on the clearcut side and variably about 20-m wide on the road side. These leave-strips form corridors of forest vegetation between relatively undisturbed areas.

To sample each of these plots two parallel rows of 10 stations were placed on opposite sides of the creek. The stations within a row were 10-m apart and each station was 2.5-m from the edge of the creek. In most instances the stations were within or next to the riparian zone. One live-trap, one snap trap, and one pitfall, partially filled with water, were placed within 2-m of each station marker. The traps were tended for 10 consecutive days, 7-16 October 1980, and the pitfall traps were left in place for an additional five days.

#### Results and Discussion

Frequencies of small mammals in the samples from the Middle Creek full forest and streamside leave-strip plots were not significantly different ( $p > 0.05$ ). Examination of table 5 indicates that sample size, an indication of abundance, is slightly lower in the leave-strip plot but that species composition is very similar in the two plots. Species richness and diversity are similar

Table 5.--Small-mammal abundance, diversity, and similarity in full-forest and leave-strip plots at Middle Creek.

Species	Full-forest	Leave-strip
Deer mouse	6	13
California red-backed vole	6	5
Trowbridge's shrew	18	12
Siskiyou chipmunk	11	8
Jumping mouse	6	2
Pacific shrew	4	1
Northern flying squirrel	1	0
Long-tailed vole	1	0
Bushy-tailed woodrat	0	2
Shrew-mole	0	1
Total species	8	8
Total individuals	53	44
Diversity (H)	2.27	2.16
Evenness (J)	.853	.827
Species in both	6	
Quotient of similarity	.750	
Percent similarity	74.9	

for the two plots and the community similarity indices are high. Two species are unique to the samples from each plot, but sample sizes for these four species are low. The jumping mouse, Pacific shrew, and shrew-mole, species closely tied to the riparian zone, were found in the leave-strip. The California red-backed vole, an apparent forest obligate, was also found in the forest leave-strip. The northern flying squirrel, another forest obligate, was not found in the leave-strip. This may be because of inadequate sampling (only one was caught in the full-forest area) or lack of minimum area for home range.

Sourgrass Creek yielded similar results. Since the species frequencies of small mammals captured within the two full-forest plots (A and D) and within the two leave-strip plots (B and C) were not significantly different ( $p > 0.05$ ) each type was combined (table 6) for further analysis. Capture frequencies in the full-forested and leave strip plots are not significantly different ( $p > 0.05$ ). Measures of diversity and community similarity also show the two types of plots to be very similar. Of interest is the maintenance of the high numbers of California red-backed voles, a forest obligate, in the leave-strips.

Although the Middle Creek and Sourgrass Creek sites differ in location, size of stream and associated riparian zone, and size of leave strips, they yielded similar results. It appears that many small-mammal species are able to utilize forest riparian leave-strips to the extent that their composition and abundance are maintained at normal levels. However, much remains to be learned about the effects of variations in such vegetation strips. Size, both length and width, and degree of connectivity with similar habitat are variables that undoubtedly affect some species.

Table 6.--Small-mammal abundance, diversity, and similarity in full-forest and leave-strip plots at Sourgrass Creek.

Species	Full-forest	Leave-strip
Deer mouse	10	12
California red-backed vole	32	36
Trowbridge's shrew	18	20
Pacific shrew	4	4
Creeping vole	0	2
Siskiyou chipmunk	1	0
Shrew-mole	1	0
Total species	6	5
Total individuals	66	74
Diversity (H)	1.69	1.67
Evenness (J)	.712	.773
Species in both	4	
Quotient of similarity	.727	
Percent similarity	96.1	

#### DISCUSSION AND CONCLUSIONS

Streamside riparian zones of low to mid-elevation mixed-conifer forests of southwestern Oregon are inhabited by small-mammal communities that are more diverse and generally more dense than in neighboring habitats. The riparian habitat contains virtually all the small-mammal species that are present in the neighboring transition and upland zones, but the reverse situation is not true. A streamside vegetative leave-strip appears to maintain riparian communities of small mammals at levels comparable to nearby undisturbed areas.

Forest riparian corridors have been suggested as a means of linking forest habitat islands such as old-growth Douglas-fir (Harris 1984). Evidence from this study indicates that such a management strategy might serve small mammals very well. But terrestrial small mammals are relatively sedentary compared to other wildlife, and it is likely that larger leave-strips might be required to satisfy the requirements of permanent living space for more vagile species. Nevertheless, judging by these small-mammal studies, even small leave-strips that include riparian habitat have greater potential for serving as travel or dispersal corridors between larger habitat islands than leave-strips in other zones. This is certainly not unexpected since the riparian zone is more environmentally diverse and can, hypothetically, provide habitat requirements for a greater variety of wildlife than other forest habitats. The fact that streamside leave-strips maintain populations of several types of small mammals indicates that a variety of food niches are also maintained. The small mammals themselves may serve as food for larger predatory wildlife that use the strip for travel from one large habitat area to another. Optimum or minimum size of streamside leave-strips that are self-maintaining and can provide habitat for both

resident and transient wildlife remains to be determined.

#### ACKNOWLEDGEMENTS

This project was supported by the Bureau of Land Management, Oregon State Office. Bureau personnel participating directly in the study included Dave Montgomery, Joe Lint, Cliff Oakley, and especially Jerry Mires and Joe Witt. Bill Neitro provided direction and support throughout the study. Student field assistants included Scott Peets, Jeff Henry, Dianne Seymour, Joe Beech, and Les Mayer. Claire Farrell, Russell Davis, and Bill Gaud, who also aided with the statistics, reviewed drafts of the manuscript.

#### LITERATURE CITED

- Black, J. C., and E. F. Hooven. 1974. Response of small-mammal communities to habitat changes in western Oregon. p. 177-186. In H. C. Black, ed. *Wildlife and reforestation in the Pacific Northwest*. 236 p. School of Forestry, Oregon State University, Corvallis, Oreg.
- Brower, J. E., and J. H. Zar. 1984. *Field and laboratory methods for general ecology*. 266 p. Wm. C. Brown Co., Dubuque, Iowa.
- Campbell, T. M., and T. W. Clark. 1980. Short-term effects of logging on red-backed voles and deer mice. *Gr. Basin Nat.* 40(2):183-189.
- Franklin, J. F., and C. T. Dyrness. 1973. *Natural vegetation of Oregon and Washington*. USDA For. Serv., Gen. Tech. Rep. PNW-8. 417 p. Pac. Northwest For. and Range Exp. Stn., Portland, Oreg.
- Gashwiler, J. S. 1970. Plant and mammal changes on a clearcut in western Oregon. *Ecology*. 51:1018-1026.
- Harris, L. D. 1984. *The fragmented forest--Island biogeography theory and the preservation of biotic diversity*. 211 p. Univ. Chicago Press, Chicago, Ill.
- Hooven, E. F., and H. C. Black. 1976. Effects of some clear-cutting practices on small-mammal populations in western Oregon. *Northwest Sci.* 50(4):189-208.
- Johnson, R. R., and D. A. Jones, tech. coord. 1977. *Importance, preservation, and management of riparian habitat: A symposium*. [Tucson, Ariz., July 9, 1977.] USDA For. Serv., Gen. Tech. Rep. RM-43, 217 p. Rocky Mt. For. and Range Exp. Stn., Fort Collins, Colo.
- Maser, C., B. R. Mate, J. F. Franklin, and C. T. Dyrness. 1981. *Natural history of Oregon coast mammals*. USDA For. Serv., Gen. Tech. Rep. PNW-133, 496p. US Print. Off. Washington, D.C.
- Thomas, J. W., C. Maser, and J. E. Rodiek. 1979. *Riparian zones*. Pp. 40-47. In J. W. Thomas, ed. *Wildlife habitats in managed forests--The Blue Mountains of Oregon and Washington*. USDA For. Serv., Agric. Hndbk. No. 553. US Print. Off. Washington, D.C.

# Channel Response of an Ephemeral Stream in Wyoming to Selected Grazing Treatments<sup>1</sup>

Ronald E. Siekert, Q.D. Skinner,<sup>2</sup>  
M.A. Smith, J.L. Dodd, J.D. Rodgers<sup>2</sup>

---

Studies of the effects of seasonal grazing on ephemeral stream morphology are summarized. Results indicate that spring grazing has no significant effect on channel morphology. Summer and fall grazing is associated with increases in channel cross-sectional area, with the degree of these impacts varying with climatic differences. Seasonal grazing can be used as a management tool for modifying channel morphology to promote channel stabilization.

---

## INTRODUCTION

Domestic livestock overgrazing is one factor commonly cited as a major contributor to gullying and arroyo cutting in the semi-arid western United States (Peterson 1950, Antevs 1952). Increased erosion and stream bank destabilization from riparian zone user activities, including widening and shallowing of channels, is well documented on perennial streams (Meehan and Platts 1978, Platts 1981, Gunderson 1968). However, grazing effects on ephemeral channels have not been well explored.

Using cross-section methodology developed by Robinson (1982) to determine site specific impacts by users of riparian zones, the University of Wyoming Range Management Department, with the cooperation and support of the Bureau of Land Management and the Wyoming State Department of Environmental Quality, initiated a five year study in the fall of 1982. Goals of this multifaceted study include identifying the effects of seasonal grazing on a riparian area associated with an ephemeral stream and management practices to reclaim riparian habitats and mitigate downstream sediment related problems.

## SITE DESCRIPTION

The study area is located on the ephemeral 15 Mile Creek drainage in north-central Wyoming. This is a semi-arid region with an average

annual precipitation of 7.76 inches. Over one-half of the annual total occurs in the three month period April through June. Soils in the area derive from marine shales and are quite erosive. The principle land use activity in the area is livestock grazing on BLM allotments.

A study enclosure is located near the mouth of the Middle Fork tributary of the 15 Mile Creek drainage. It is a 600 ac pasture subdivided into five interior cells. Each cell is approximately 120 ac in extent. Additional unfenced study reaches are located above the enclosure on the Middle Fork, and further down the drainage system on both the main stem and the section below the confluence of Middle and South Fork for general drainage monitoring. The three interior cells of the Middle Fork enclosure are reserved for repeated seasonal grazing trials. The upstream and downstream cells are a non-grazed control and a cell reserved for bank manipulations respectively. Each pasture contains two study reaches, one centered on a meander, the other on a straight channel section. All measurements and installations are focused on these study reaches with the exception of animal behavior observations (Fig. 1).

## METHODS

Seasonal grazing trials were conducted in May, June, and September of 1983 and 1984 in the enclosure. Trials consist of the introduction of thirty (30) cow-calf pairs to the appropriate cell for a ten day period. Measurements taken in association with these trials include: channel morphology, extended cross-section measurements, cattle behavior observations, and vegetation utilization.

---

<sup>1</sup>Paper presented at the first North American conference, University of Arizona, Tucson, April 16-18, 1985.

<sup>2</sup>R. Siekert - Research Associate, Q.D. Skinner, M.A. Smith, J.D. Rodgers, J.L. Dodd - Associate Professors of Range Management, University of Wyoming, Laramie, Wyoming.



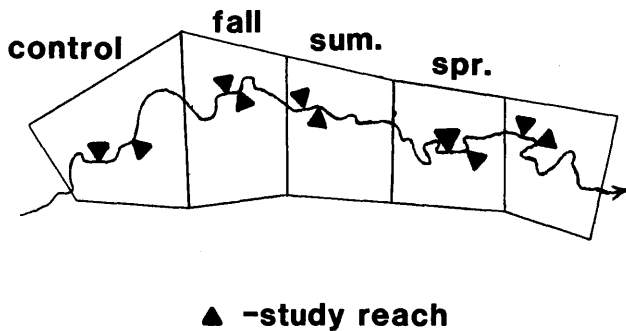

Figure 1. 15 Mile Creek study enclosure seasonal grazing cells.

Channel morphology measurements are taken on five equally spaced cross-sections encompassing each study reach. Data is collected on each cross-section by stringing a leveled line between permanent end points. The vertical distance from this reference to the channel is then recorded at intervals of one-tenth (.10) of the channel top width. The position and depth of the interim banks are also recorded at each cross-section. Measurements are taken prior to and following each trial in the study and upstream control cell. The data collected from these cross-sections is used to develop mean channel depths and channel cross-sectional areas. Changes in area are determined by subtracting the pre-grazing area from the post-grazing for both the trial reaches and the control. F-tests are used to determine if the mean changes occurring in the grazing and control cells differ at the  $\alpha = .10$  level.

Extended cross-section surveys are taken concurrently with morphology measurements. These surveys are run with a level and stadia rod on lines extending from the cross-section endpoints to pins situated twenty feet into the floodplain on either side of the channel. Stadia readings are taken at one foot intervals to monitor cattle trampling effects on the near-bank floodplain. Data treatment is similar to channel morphology area analysis.

Animal behavior observations consist of locating each animal in the grazing cell at fifteen minute intervals and recording their activity, location by habitat type, distance to shade and water, and the accompanying climatic conditions. Observations are conducted for six days, dawn to dusk, during each trial. Habitat types are classified as upland, floodplain, and channel (which includes a 10 yard band on either

side). Activities recorded include feeding, resting, and traveling.

Vegetation utilization by cattle is monitored using multiple transects of marked plants. Fifty individuals each of eleven species sufficiently abundant to contribute to forage resources are permanently marked with pins in each grazing cell. Evaluation of utilization is accomplished by weight estimation of aboveground biomass by a trained observer immediately prior to and following the cattle grazing. All weights are corrected to a dry matter basis, using plants harvested at the time of observer calibration and dried. Additional samples of each species are collected for crude protein analysis. Analysis of variance and t- tests are used for data evaluation.

## RESULTS

Comparison of study and control reaches in 1983 and 1984 show no significant change in mean reach depth in response to season of grazing. Additionally, no significant difference in mean depth is noted on any reach between years. In both 1983 and 1984, no change in channel area arising from spring grazing was observed. Summer grazing in 1983 resulted in an overall increase in channel area as compared to the control. Fall 1983 comparisons are unavailable. In 1984, the study reaches in the summer and fall grazing cells increased in cross-sectional channel area, but less so than the control reaches in the same periods (Table 1).

Table 1. Means and standard deviations of cross-sectional area changes<sup>1</sup> (ft<sup>2</sup>) in treatment and control pastures by season and year.

YEAR	SEASON	TREATMENT		CONTROL	
		$\bar{x}$	s	$\bar{x}$	s
1983	SPRING	1.30	6.09	1.04	4.65
	* SUMMER	-1.04	2.51	2.47	3.07
	FALL	-0.09	3.17	--	--
1984	SPRING	1.31	4.30	0.08	3.73
	* SUMMER	-1.37	1.97	-3.63	1.65
	* FALL	-1.11	4.78	-5.79	5.00

<sup>1</sup> Pre-grazing minus post-grazing area. Negative (-) values indicate an area increase.

\*Treatment and control reaches are significantly different at the  $\alpha = .10$  level.

In contrast, the extended surveys displayed no significant changes in 1983 or 1984 in any trial with the exception of the summer in 1983. Measurements from that period indicate that the area under the survey line reference increased.

Behavior observations, conducted in conjunction with the 1984 trials, indicated the

percentage of animals located on the channel in the spring was less than one-half of the percentage sighted there in the summer and fall. Occurrences in the upland remained relatively constant, declining somewhat in the summer trial and rebounding in the fall. Cattle occurrence in the floodplain declined steadily spring to fall (Table 2).

Utilization of the vegetation species most closely associated with the channel displayed a steady increase spring to fall (25.5% to 61.1%). Floodplain species utilization increased slightly as the season progressed (33.1% to 39.4%). Upland vegetation utilization was similar in the

Table 2. Percentages of total cattle numbers observed by season and proportion of habitat type.

	HABITAT					
	CHANNEL		TERRACE		UPLAND	
	% pas.	% cattle	% pas.	% cattle	% pas.	% cattle
Spring	2.0	7.6	12.6	39.5	85.4	54.0
Summer	1.3	16.5	12.6	34.5	86.1	49.0
Fall	2.3	16.0	19.3	26.3	78.4	57.7

spring and summer (30.1% and 35.3%), and climbed sharply in the fall (51.3%). Threshold levels of utilization considered detrimental were not exceeded for most species.

#### DISCUSSION

Relatively intense short-term grazing, applied in the spring season, appears to have no adverse effect on channel morphology in the Middle Fork enclosure. The degree and character of the changes associated with the seasonal trials is quite similar over both years. Apparent variations in grazing cell channel response relative to the control in a given year are due to the ungrazed control's response to variations in flow frequency and volume rather than to differences in the study pasture's response. The first year, 1983, proved to be a very wet year, especially in the late summer. Sediment deposition on banks was high during the summer trial as evidenced by repeated difficulties in locating pins marking plants for measurement of utilization of bank vegetation. Some of these pins, originally at ground level, were covered with sediment over one inch deep in the ten-day trial period. In contrast 1984 was generally drier with less frequent flows, the exception being the fall trial which had two separate flow events in the ten day period.

The nature of the streams morphological response to grazing did not vary. The stream

channel maintained mean depth through all treatments and trials. Increases in channel area changes resulted from a flattening of channel slopes or "dishpanning" of the channel. This conclusion is supported by plots of cross-sections.

All significant morphologic effects in the grazing cells in 1984 corresponded to increased cattle occupancy of the channel habitat type. This change in the animals habitat preference appears to stem from two factors: 1) forage related factors such as palatability, nutrient value, and growth form and 2) environmental factors--specifically the cattle shading up under cottonwood trees (Populus sargentii) as the day-time temperatures increased.

#### CONCLUSION

These results suggest that manipulation of the season of grazing can be used as a management tool in ephemeral stream situations. Grazing could be used not only as a passive factor, as in the withholding of grazing to preserve a systems integrity, but as an active agent of change. Conceivably, incised streams with relatively sheer banks could be modified by selected seasonal grazing pressure. With proper attention to vegetation utilization and climatic factors, channel shape could be modified by controlled grazing to a rounded form. Channel modifications accomplished in this manner would require careful timing and management, but the intermittent character of flow events would present the opportunity for vegetative encroachment and stabilization of the new bank form. This vegetation, properly managed, would serve in turn as a sediment trap, promoting channel healing.

#### LITERATURE CITED

- Anteves, E. 1952. Arroyo cutting and filling. *J. Geol.* 60:375-385.
- Gunderson, Donald R. 1968. Floodplain use related to stream morphology and fish populations. *J. of Wildl. Mgt.* 32(3): 508-514.
- Meehan, W.P., Platts, W.S. 1978. Livestock grazing and the aquatic environment. *J. Soil and Water Cons.* 33(6): 274-278.
- Peterson, H.V. 1950. The problem of gullying in western valleys pp. 407-434 In: *Applied Sedimentation*, John Wiley and Sons, Inc., New York, NY.
- Platts, W.S. 1981. Sheep and cattle grazing strategies on riparian stream environments. pp. 251-270. In *Proc. Wildlife-Livestock Relationships Symposium, 1981*. University of Idaho, Forest, Wildlife, and Range Experiment Station, Moscow, ID.
- Robinson, J.L. 1982. Development and Testing of a Stream Morphology Evaluation Method for Measuring User Impact on Riparian Zones. M.S. Thesis, University of Wyoming, Laramie, Wyoming.

# Time of Grazing and Cattle-Induced Damage to Streambanks<sup>1</sup>

Clayton B. Marlow<sup>2</sup> and Thomas M. Pogacnik<sup>3</sup>

---

Abstract.--Cattle impact riparian communities through two processes: grazing and trampling. Re-evaluation of management practices indicates that implementation of rest rotation grazing management and limiting cattle use of riparian vegetation to 20% of the standing crop will reduce impact. Rest rotation and light grazing may improve plant vigor but little information is available on how well either practice controls bank damage from trampling. A three-year grazing study in southwestern Montana indicates that the level of cattle use in the riparian zone has little bearing on streambank damage ( $r^2=0.06$ ). Soil moisture content directly affects ( $r^2=0.85$ ) the streambanks susceptibility to trampling. Postponing or deferring grazing until streambanks have dried (<10% soil moisture) will further protect the riparian zone from damage.

---

Degradation of western riparian zones has been largely attributed to cattle grazing (Leopold 1974, Behnke and Zarn 1976, Behnke and Raleigh 1978, Oregon-Washington Interagency Wildlife Council 1978, Platts 1979, and Davis 1982). Cattle contribute to declines in riparian community stability and water quality by removing protective vegetation (grazing) and increasing bank instability through trampling. Unstable banks then lead to accelerated erosion and elevated instream sediment loads (Winegar 1977 and Duff 1979) while the corresponding heavy use of vegetation increases sediment production due to elevated surface runoff (Rauzi and Hanson 1966). Reduction in vegetative cover may also lead to higher water temperatures (Johnson et al. 1977 and Van Velson 1979) which are counterproductive for aquatic vertebrate and invertebrate populations. These impacts have arisen due to past management or the lack thereof (Platts 1978). In many cases, riparian zones have been ignored in the planning process because their limited extent made them "sacrifice areas" (Skovlin et al. 1977). Very often the "sacrifice" condition was created by incorporation of streamside areas into large pastures and not identifying them as separate and distinct management units (May and Davis 1982). As an outgrowth of this oversight problem, the Western Division American Fisheries Society (1979)

recommended inclusion of riparian concerns at all planning levels, and the rapid development of management practices that would reduce riparian degradation.

Platts (1979) expressed doubt that existing grazing management strategies were capable of correcting cattle impacts in riparian habitats, but several management alternatives have recently been re-examined. May and Davis (1982) recommended light grazing levels (20% forage removal) and changes in pasture design to alleviate cattle-induced problems. Rest rotation grazing systems appear to have promise for rehabilitating riparian areas without excluding cattle for long periods (Kaufman and Krueger 1984), although some managers (Armour 1978, Storch 1979, and Platts 1982) question the effectiveness of rest rotation for long-term riparian improvements. The limited acceptance of rest rotation to protect riparian zones arises from a lack of consistent research results (Kaufman and Krueger 1984). Inconsistencies may be the result of inadequate information to develop site specific criteria for protection of the riparian resource or from a variety of different experimental purposes and procedures all being lumped as "rest rotation".

Any grazing system relies on the control of the season and frequency of grazing to be effective. Consequently, managers must know how each component of the ecosystem (soils, vegetation, and animals) reacts to grazing at different times of the year. Although May and Davis (1982) and Platts (1982) suggest that light grazing will produce improvements in the riparian zone, little information is available on how streambanks respond to trampling at different times during the year. Light grazing use may protect the vegetation, but we know little about

---

<sup>1</sup>Paper presented at the North American Riparian Conference. (The University of Arizona, Tucson, April 15-19, 1985).

<sup>2</sup>Clayton B. Marlow is Assistant Professor, Animal & Range Sciences, Montana State University, Bozeman, MT.

<sup>3</sup>Thomas M. Pogacnik is Range Conservationist, USDI Bureau of Land Management, Tonopah, NV.

concurrent levels of bank damage. Information on bank damage in relation to season of grazing could be incorporated into the development of riparian grazing strategies and thereby improve the likelihood of success.

In 1981, a study was initiated in southwestern Montana to determine the relationship between the time of cattle grazing and riparian degradation. Because foothill ranges are traditionally used from June to October, cattle grazed the study site from the third week of June until the first few days of October. Another common management practice on these ranges is to base cattle stocking rates on a 50% removal of the standing forage crop. This was also followed to make study results as applicable as possible to current grazing management strategies.

#### STUDY SITE DESCRIPTION

The riparian study was conducted on a small tributary of the Madison River in southwestern Montana (Fig. 1). Both the stream and its headwaters are located on the Montana Agricultural Experiment Station's Red Bluff Research Ranch. The Cottonwood Creek watershed (1360 ha) is characterized by moderate to steep slopes with elevations ranging from 2000 m at the headwater spring to 1400 m where it enters the Madison River. The stream is bordered on the south by slopes of 30-50 percent and on the north by rolling hills with 15 to 30 percent slopes.

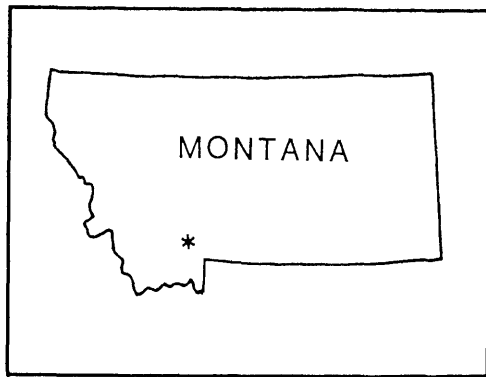

Figure 1.--Location of study site in southwestern Montana.

The riparian community is dominated by Kentucky bluegrass (*Poa pratensis* L.), reedtop (*Agrostis stolonifera* L.), timothy (*Phleum pratense* L.), smooth brome (*Bromus inermis* Leyss.), beaked sedge (*Carex rostrata* Stokes), Sprengel's sedge (*Carex sprengelii* Dewey), and white clover (*Trifolium repens* L.). Overstory includes quaking aspen (*Populus tremuloides* Michx.), willow (*Salix* spp. L.), chokecherry (*Prunus virginiana* L.), and swamp gooseberry (*Ribes lacustre* (Pers.) Poir.).

The upland communities support Kentucky bluegrass, green needlegrass (*Stipa viridula* Trin.), needleandthread (*Stipa comata* Trin. & Rupr.), bluebunch wheatgrass (*Agropyron spicatum*

(Pursh.) Scribn. & Smith), western wheatgrass (*Agropyron smithii* Rydb.), Idaho fescue (*Festuca idahoensis* Elmer), and cheatgrass brome (*Bromus tectorum* L.). Scattered dense stands of mountain big sagebrush (*Artemisia tridentata* ssp. *vasevana* (Rydb.) Beetle) interspersed with Wood's rose (*Rosa woodsii* (Lind) L.) and Rocky Mountain juniper (*Juniperus scopulorum* Sarg.) occur throughout.

Cottonwood Creek is small (average flow  $0.16 \text{ m}^3 \text{ s}^{-1}$ ) with channel substrate composed of angular gravel, silt, and fine clay. Banks have less than 20% of their total volume composed of rock or gravel.

Mean daily air temperatures range from  $20^\circ\text{C}$  in July and August to  $-11^\circ\text{C}$  in December. The 400 to 500 mm of total annual precipitation occurs primarily as snowfall during October through March and rainfall during May and June. Precipitation from thunderstorms in July, August, and September contribute less than 20% of the annual total.

#### METHODS

A 5.5 ha section of Cottonwood Creek was fenced in the spring of 1981. Nine 0.6 ha paddocks, each containing equivalent amounts of upland and riparian communities were created by cross fencing the original enclosure (Fig. 2). One paddock served as an ungrazed control, the other eight were grazed sequentially, as follows: beginning with the paddock furthest downstream, four head of yearling cattle were grazed in each paddock for 14 days. Paddocks were grazed in order to prevent upstream use from confounding time of year effects. Once the paddock was grazed, it was not grazed again until the next year, when it was grazed at the same time.

Streamflow was measured continuously with Parshal Type Flumes equipped with stage level recorders at the downstream edge of each paddock. Moisture content of streambanks was measured at two points in each paddock every time the cattle were moved. This provided nine sample dates from early June until early October. Percent moisture content of the soil column was determined at 15 cm, 30 cm and 45 cm depths by the neutron scattering technique (McHenry 1963). Channel damage was monitored by establishing five permanent channel cross section transects in each paddock. The vertical distance from the level transect line to the channel bed was measured at 10 cm horizontal intervals (Fig. 3) prior to cattle grazing and immediately afterward. The post-grazing cross-sectional area was then compared to the pre-grazing area to determine the magnitude of change during the grazing period. Differences were tested for significance at the 0.05 level with a standard paired t test (Gomez and Gomez 1984).

Cattle use patterns were based on two, 24 hour observation periods each week in 1982 and 1983. This produced 32 observations from early June until early October each year. The activity (feeding or resting) and community (riparian or

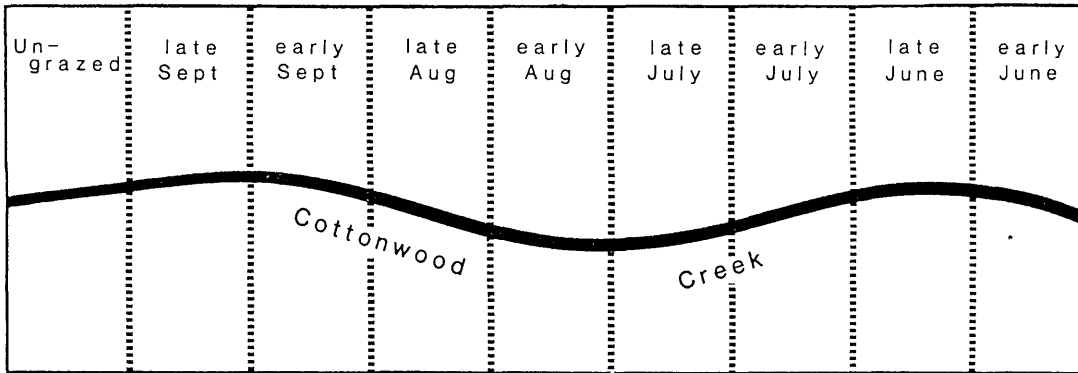

Figure 2.--Experimental pasture design and respective grazing periods.

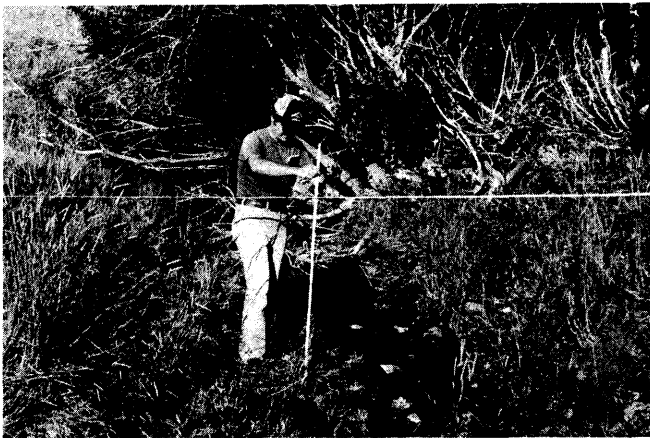

Figure 3.--Measuring channel area along a permanent transect line.

upland) occupied by each heifer was recorded hourly during each observation period. The number of observations for each activity category and location was totaled for each grazing period. Differences in the number of observations for feeding and resting in upland and riparian communities during each period were tested for significance at the 0.05 level with a standard paired t test (Gomez and Gomez 1984).

#### RESULTS

Cattle use of riparian and upland communities exhibited a definite seasonal pattern (Fig. 4). In general, upland use declined from late June to August while riparian use increased. During the last half of the grazing season, use in both community types remained fairly constant except during early September when snows forced cattle into the uplands. Changes in stream channel area also showed a seasonal trend (Fig 5) but were the

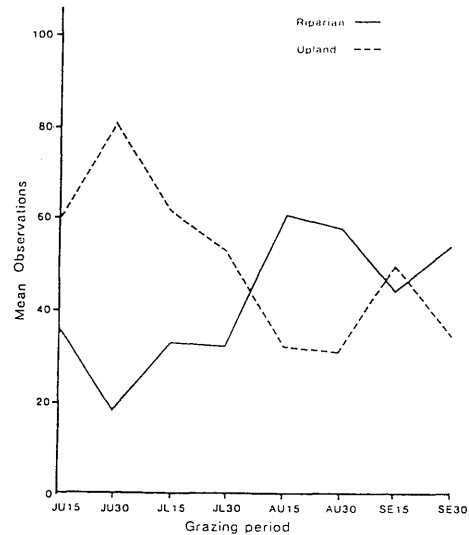

Figure 4.--Seasonal cattle use of riparian and upland zones (average of 1982 and 1983 observation totals).

reverse of cattle use patterns (Fig. 6). Increased use of riparian communities by cattle explained very little ( $r^2 = 0.06$ ) of the change in channel area during each grazing period.

Examination of streambank moisture content provided a possible explanation for the apparent lack of affect from trampling. Moisture levels declined until early September when snowfall began to recharge the soil profile (Fig. 7). Streambank change was significantly correlated ( $P < 0.05$ ) with soil moisture content (Fig. 8). As bank moisture content increased, so did the amount of change in channel area. Although changes increased in early September with snowfall induced recharge, frozen banks limited trampling damage. Changes in channel area during August and September were not significantly different ( $P < 0.05$ ) from changes

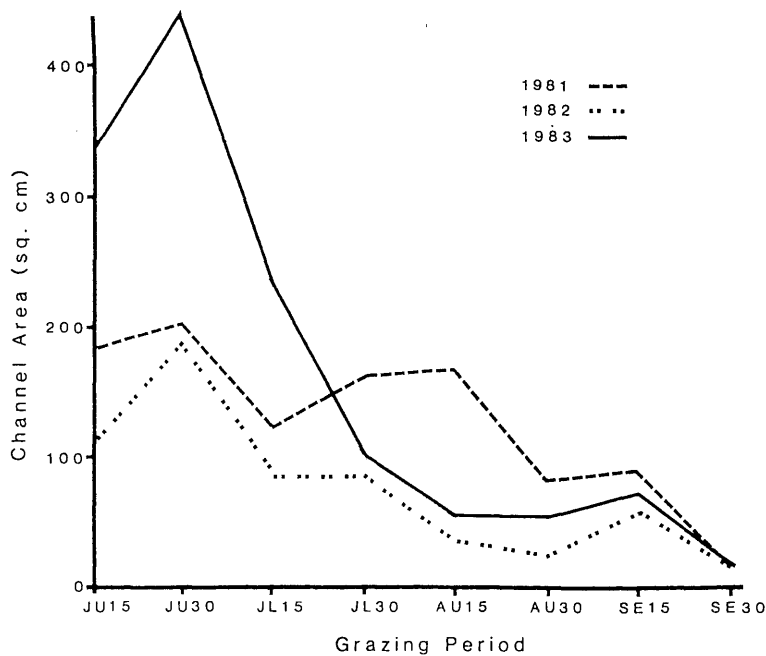

Figure 5.--Seasonal changes in channel area for 1981-1983.

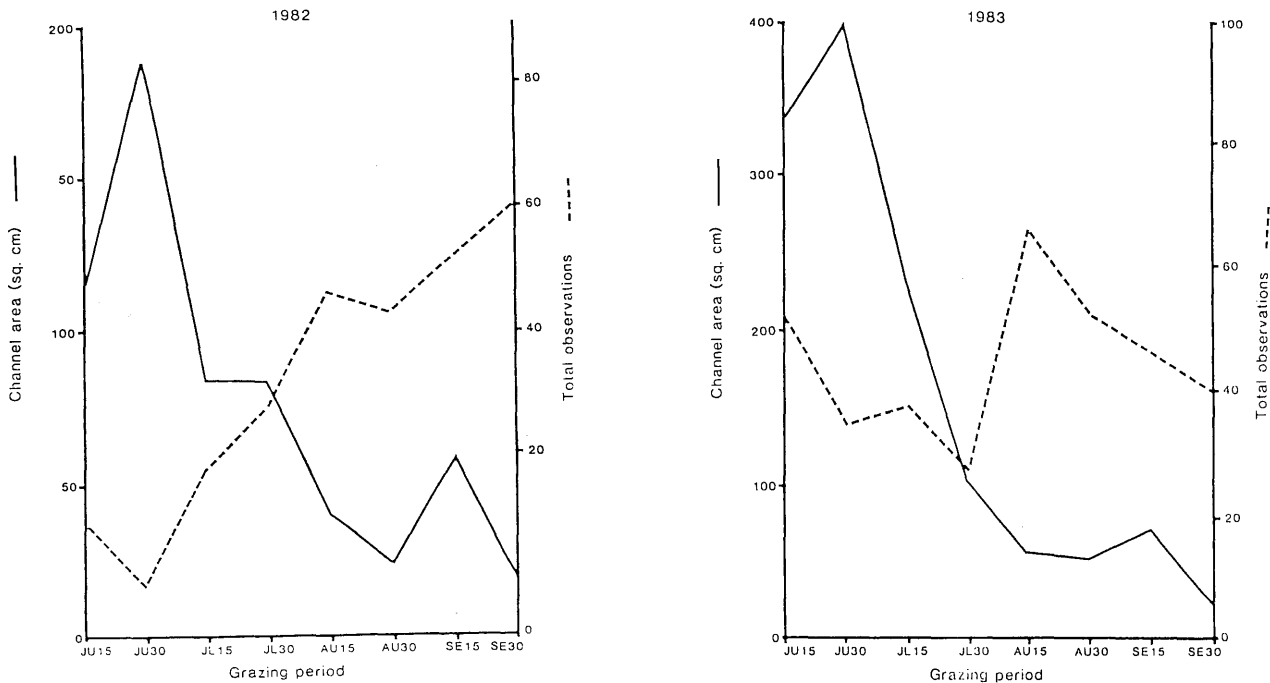

Figure 6.--Comparison of changes in channel area and corresponding cattle use of adjacent riparian communities.

which occurred in the ungrazed paddock. Stream-bank moisture content explained 71% - 85% of the bank susceptibility to change during all three years of the study. The greater level of change which occurred in 1983 may have been caused by dry spring conditions which caused cattle to spend more time in the riparian communities during June.

#### CONCLUSIONS

Cattle induced impacts on streambank stability are not related to the level of riparian use. The greatest amount of bank alteration occurs when soil moisture exceeds approximately 10%. In the arid and semi-arid regions of the

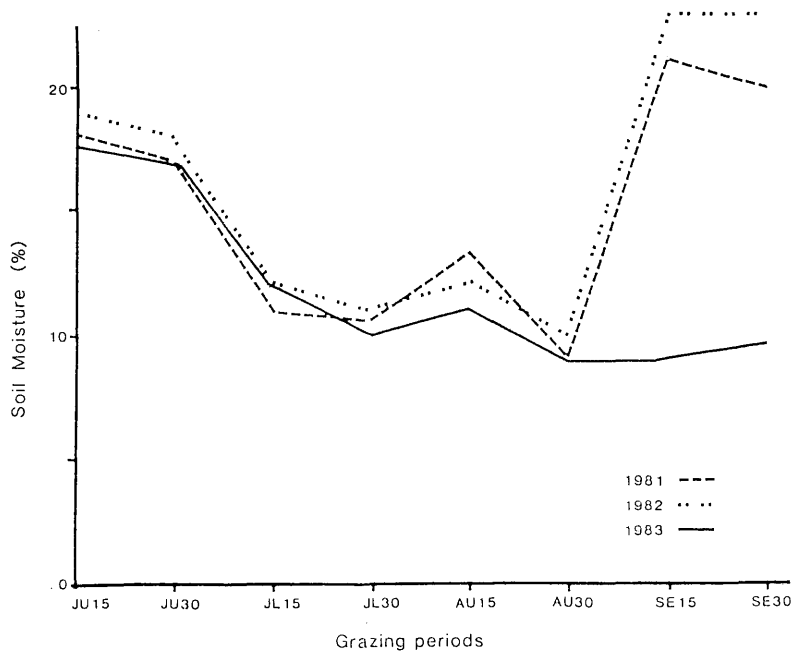

Figure 7.--Seasonal soil moisture content of streambanks (average of top 45 cm).

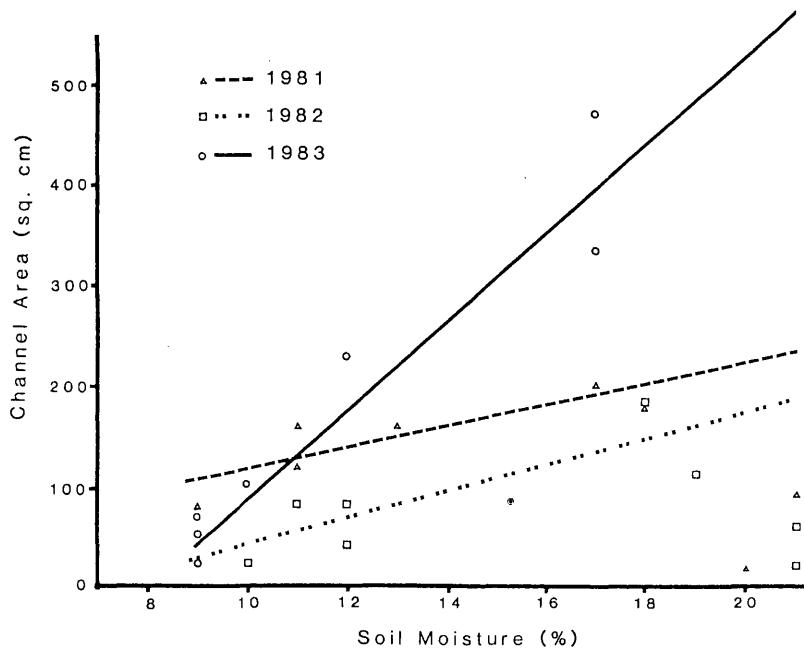

Figure 8.--Relationship between streambank moisture content and level of channel area change (straight lines were fitted with use of a linear regression equation).

western United States, soil moisture usually falls below this level in late July or early August. Autumn recharge of the soil profile does not appear to intensify impact because banks freeze and are less susceptible to trampling.

Because of the grazing susceptibility of moist streambanks, reduction in cattle numbers will produce little riparian improvement. Fewer cattle will simply restrict bank damage to

localized spots in the pasture. These damaged areas, although infrequent, will continue to contribute to further riparian degradation. This can be avoided by deferring cattle use until after banks have dried sufficiently to limit trampling damage. The length of the grazing period can then be based on the recommended level of forage utilization within the riparian zone (Platts 1982, May and Davis 1982). The additional cross-fencing necessary to gain this level of grazing control

will also improve grazing management in the adjacent uplands. Early season cattle use can be alternated among pastures so each pasture is only grazed during June and July once every four or five years.

Integration of this type of grazing management into the overall resource management program should enhance the potential for riparian improvement and protection.

#### LITERATURE CITED

- Armour, Carl. 1978. Livestock management approaches and the fisheries resource. p. 39. In Proc., Forum - Grazing and Riparian/Stream Ecosystems. Trout Unlimited, Inc.
- Behnke and Zarn. 1976. Biology and management of threatened and endangered western trout. USDA For. Ser. Gen. Tech. Rep. RM-28, 45 pp. Rocky Mountain For. and Range Exp. Sta., Fort Collins, CO.
- Behnke and Raleigh. 1978. Grazing and the riparian zone: Impact and management perspectives. pp. 184-185. In Strategies for Protection and Management of Floodplain Wetlands and Other Riparian Ecosystems. USDA For. Ser. GTR-WO-12.
- Davis, J.W. 1982. Livestock vs. riparian habitat management - there are solutions. pp. 175-186. In Wildlife - Livestock Relationships Symposium: Proc. 10. Univ. Idaho, For., Wildl. and Range Exp. Sta., Moscow, ID.
- Duff, D.A. 1979. Riparian habitat recovery on Big Creek, Rick County, Utah. p. 91. In Proc. Forum - Grazing and Riparian/Stream Ecosystems. Trout Unlimited, Inc.
- Johnson, R.R., L.T. Haight and J.M. Simpson. 1977. Endangered species vs. endangered habitats: a concept. pp. 68-79. In Importance, Preservation and Management of Riparian Habitat. USDA For. Ser. Gen. Tech. Rep. RM-43. pp. 68-79.
- Kaufman, J.B. and W.C. Krueger. 1984. Livestock impacts on riparian ecosystems and streamside management implications...a review. J. Range Manage. 37(5):430-437.
- Leopold, A.S. 1974. Ecosystem deterioration under multiple use. Proc. Wild Trout Management Symposium. pp. 96-98. USDI Fish and Wildl. Ser. and Trout Unlimited, Denver, CO.
- May, B. and B. Davis. 1982. Practices for livestock grazing and aquatic habitat protection on western rangelands. pp. 271-279. In Wildlife-Livestock Relationships Symposium: Proc. 10. Univ. Idaho, For., Wildl. and Range Exp. Sta., Moscow, ID.
- McHenry, J.R. 1963. Theory and application of neutron scattering in the measurement of soil moisture. Soil Sci. 95:294-307.
- Oregon-Washington Interagency Wildlife Council. 1978. Managing riparian zones for fish and wildlife in eastern Oregon and eastern Washington. Unpub.
- Platts, W.S. 1978. Livestock interactions with fish and their environments: Tran. 43rd North Amer. Wildl. and Natural Res. Conf. 1978. Wildl. Manage. Inst. Washington, D.C.
- Platts, W.S. 1979. Livestock grazing and riparian/stream ecosystems. pp. 39-45. In Proc., Forum-Grazing and Riparian/Stream Ecosystems. Trout Unlimited, Inc.
- Platts, W.S. 1982. Sheep and cattle grazing strategies on riparian-stream environments. pp. 251-270. In Wildlife-Livestock Relationships Symposium: Proc. 10. Univ. Idaho For., Wildl. and Range Exp. Sta., Moscow, ID.
- Rauzi, F. and C.L. Hanson. 1966. Water intake and runoff as affected by intensity of grazing. J. Range Manage. 19:351-356.
- Skovlin, J.M., W.R. Meehan, J.C. Buckhouse and M. Vavra. 1977. A method of study for determining the influence of grazing on riparian and aquatic habitats in the Blue Mountains of Oregon. In Proc. Symp. Livestock Interactions with Wildlife, Fisheries and Their Environments. USDA For. Ser. Pac. Southwest For. and Range Exp. Sta., Berkeley, CA.
- Storch, R. 1979. Livestock/streamside management programs in eastern Oregon. pp. 56-59. In Proc., Forum - Grazing and Riparian/Stream Ecosystems. Trout Unlimited, Inc.
- Van Velson, R. 1979. Effects of livestock grazing upon rainbow trout in Otter Creek. pp. 53-56. In Proc., Forum - Grazing and Riparian/Stream Ecosystems. Trout Unlimited, Inc.
- Western Division American Fisheries Society. 1979. Management and Protection of Western Riparian Stream Exosystems. Tualatin, OR. 24 pp.
- Winegar, H.H. 1977. Camp Creek channel fencing - plant, wildlife and soil and water response. Rangeman's J. 4:10-12.



# Livestock Management in the Riparian Ecosystem<sup>1</sup>

Larry D. Bryant<sup>2</sup>

---

Abstract.—Intensive, long-term livestock grazing has occurred along most streams in the western United States. Although most livestock grazing on public lands is now under some form of management, many riparian areas are below "good" in ecologic condition, with forage production considerably below potential. Eight years of research at Meadow Creek, Starkey Experimental Forest and Range, Wallowa-Whitman National Forest, in northeastern Oregon, indicates that herbage production was increased 1- to 4-fold through timing and intensity of grazing. Rest-rotation, deferred rotation, and season-long grazing systems were tested. Although there were no statistically different changes in plant composition, the production of both graminoids and forbs increased dramatically.

---

## INTRODUCTION

There is no question that riparian areas have been severely abused historically. Livestock grazing, logging, roads, railroads, gold dredging, and numerous other activities have all had their impacts. Few riparian areas in the western United States have not been influenced by one or more of these factors. There is little profit now in discussing what should have been done 20, 50, or 100 years ago to prevent degradation. We must deal with today's conditions.

Total exclusion of all human activities from riparian areas, is unlikely to return those areas to pristine condition, and could be unacceptable socially, economically or both. Although it will require intensive management. Alternatives to total exclusion of human uses to renovate riparian areas exist. Total exclusion of human uses or continued unchecked degradation of riparian areas are the extremes of management alternatives. Some "middle ground" in management seems a likely way to satisfy some of the desires of the parties concerned while improving condition of the resource. These goals and objectives can be best accomplished

through cooperation and coordination among user groups rather than through polarized infighting.

Fisheries biologists are to be commended for focusing attention on riparian and floodplain area and for making all resource managers more aware of not only the sensitivity but also the productivity--present and potential--of these areas.

Since 1974, numerous cooperators and I have carried out a case history study on the influence of grazing on riparian and aquatic habitats in the central Blue Mountains. Because of space constraints, I can only discuss the floodplain vegetation response to grazing by cattle.

At the onset of the study, we chose the 70 percent level of utilization of annual production on floodplain herbage as the maximum grazing limit. We established stocking levels from the 1975 production data at which we anticipated would achieve 70 percent utilization. In 1976, the first year of grazing, we achieved that level of grazing. In subsequent years utilization was consistently less than 70 percent. Meadows were in "good" condition in 1976 and we did not anticipate that the floodplain vegetation would respond dramatically to the treatments.

We also tested different grazing systems (deferred rotation, rest-rotation, and season-long grazing) commonly used on cattle allotments on National Forest land in the Blue Mountains. In addition, in other pastures we allowed grazing exclusively in riparian areas after plant maturation with 80 to 90 percent

---

<sup>1</sup> Paper presented at the North American Riparian Conference [The University of Arizona, Tucson, April 16-18, 1985].

<sup>2</sup> Larry D. Bryant is Wildlife Biologist at USDA Forest Service, Pacific Northwest Forest and Range Experiment Station, Forestry and Range Sciences Laboratory, La Grande, OR.

utilization, in a deferred rotation sequence. We called this the short-duration, high intensity (SDHI) grazing. Mule deer (Odocoileus hemionus) and elk (Cervus elaphus) are common in the area so a portion of the area was fenced to exclude their use through the grazing season.

#### STUDY AREA

The study area was a 4,000-acre block encompassing Meadow Creek, a perennial stream flowing west to east across the 30,000-acre Starkey Experimental Forest and Range, which is located 30 miles southwest of La Grande, Union County, Oregon. Prior to study implementation, the area was grazed in a deferred rotation grazing system. The season of use ran from mid-June to mid-October depending on range readiness.

Elevations range from 3,500 ft (1067 m) to 5,000 ft (1524 m). Annual precipitation averages 20 in (50 cm) of which 90 percent falls as spring and autumn rains and winter snow. The growing season is about 120 days but frost may occur in any month.

The upland vegetation is typical of mountainous rangeland throughout the Blue Mountains of Oregon and Washington and has been described by Strickler (1965) and Driscoll (1955).

The floodplain plant communities are defined by Ganskopp (1978). There are 44 plant communities occurring on approximately 121 acres (49 ha) with 9 of those communities occupying 80 percent of the floodplain area. The dominant communities are:

1. Woolly sedge (Carex lanuginosa)/ water sedge (C. aquatilis).
2. Meadow foxtail (Alopecurus pratensis)/ smooth brome (Bromus inermis).
3. Northwest cinquefoil (Potentilla gracilis)/ Kentucky bluegrass (Poa pratensis), Canada bluegrass (P. compressa).
4. Common timothy (Phleum pratense)/ Kentucky bluegrass (Poa pratensis), Canada bluegrass (P. compressa).
5. Kentucky bluegrass (Poa pratensis), Canada bluegrass (P. compressa)/ western yarrow (Achillea millefolium), common dandelion (Taraxacum officinale).
6. Gravel bar.

Meadow Creek fluctuates between 3 ft <sup>3</sup>/<sub>s</sub> to over 300 ft <sup>3</sup>/<sub>s</sub>. Peak flows

result from snowmelt and usually occur in late April. Low flows occur from late July through August and, sometimes, in September. Steelhead (Salmo gairdneri) are the only anadromous fish using the stream. Rainbow trout (Salmo gairdneri) and a variety of other fish are year-round residents.

#### MATERIALS AND METHODS

##### Pasture Configuration and Grazing Systems

The study area was divided into four phases plus a control area. Each phase was subdivided into five units (figure 1). Each unit within a phase contained approximately the same length of stream. Each unit within a phase received a different grazing treatment.

Phase I was corridor fenced to include about 95 percent of the floodplain area. The treatment was a simulated season-long grazing system where no more than 70 percent of the herbage was removed by grazing within each unit (figure 1). Starting in 1976, unit 5 was grazed at this intensity; in 1977 units 4 and 5; in 1978 units 3, 4, and 5; in 1979 units 2, 3, 4, and 5; and 1980 all units were grazed. This part of the study was designed to determine how long willow slip<sup>3</sup> plantings had to be protected from grazing before they became established.

Phase II was cross fenced and included the uplands of both north and south aspects to the top of the ridge on both sides of the creek (figure 1). Units 1 and 4 were grazed with a rest-rotation system, unit 2 was deferred rotation grazing, unit 3 was season-long grazing, and unit 5 was not grazed with cattle although mule deer and elk had access to the pasture.

Phase III was a scaled-down replicate of the grazing treatments of Phase II (figure 1). No south aspect, and only a small portion of the north aspect was included. Big game animals were excluded from all units from late May through October. Because of flow fluctuations, ice floes, and migrations of big game up and down the stream channel during the winter months the water gaps were removed after the grazing season and put back in the spring. Any big game animals found on the inside were removed at that time.

Phase IV included two pastures each of north and south aspects and two pastures confined to a corridor along the stream in the riparian area that included all floodplain

---

<sup>3</sup> Willow slip is a cutting (20-30-in[51-76-cm]long) from the previous year's shoot growth of a mature willow plant and is usually planted before bud break.

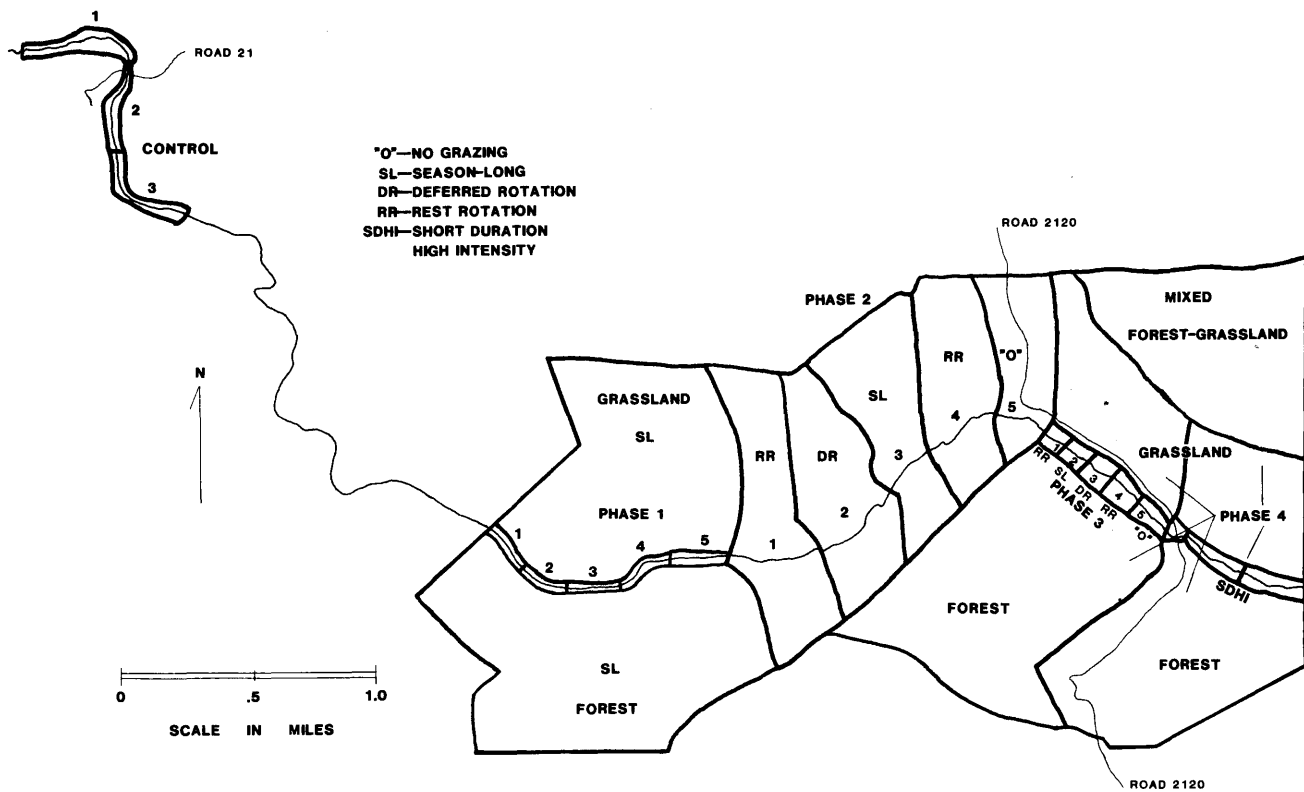

Figure 1.--Outline of Meadow Creek Study area.

plant communities (figure 1). The two riparian area pastures were grazed with a late season deferred rotation--short-duration, high intensity system. The two south aspect (grassland) pastures and the two north aspect (timbered) pastures were grazed with a rest-rotation system.

#### Vegetation Sampling

Each unit in every phase had paired plots, one fenced and ungrazed, the other unfenced and grazed, that were read in 1975, 1978 and 1981. Belt transects of 100 Daubenmire microplot frames (20 cm x 50 cm) were laid out in both plots for plant frequency and basal area studies. Frequency data were collected from both the 20- x 50-cm plot and a microplot of 10 x 10 cm. The 1- x 2-ft plot was used in vegetation production monitoring. Production data were collected from clipping every 10th plot along the belt transect and then dried for 24 hours at 60°C. In conjunction with the permanent plots, each unit had five caged plots (1 m<sup>2</sup>) on the representative plant communities for monitoring annual production and utilization. Both production and utilization were determined from plots clipped to a 1-in (2.54-cm) stubble height, a day or two after livestock were removed from the pasture.

#### RESULTS AND DISCUSSION

Preliminary results indicate production of floodplain vegetation can be improved within several grazing regimes without causing negative impacts on the aquatic system.

When utilization of annual herbage was limited to not more than 70 percent, vegetation in the riparian area responded favorably. Established water standards were met throughout the experiment in all treatments (Buckhouse et al. 1979).

While plant composition did not change appreciably, annual production of herbage increased from 1- to 5-fold. These changes can be attributed to grazing systems and level of utilization (table 1).

The season-long grazing system pastures had the least amount of improvement (1.2-fold) or 1,570 lb/acre (1758 kg/ha) in 1975 versus 3,489 lb/acre (3908 kg/ha) in 1981. On the ungrazed portions of these pastures the improvement was 1.25-fold (table 1).

The short-duration, high-intensity pastures' response has been similar to the season-long pastures' response. Grass production increased 3.0-fold in the grazed part and 3.1-fold in the ungrazed portion.

Changes are more noticeable between the grazed and ungrazed portions of the rest-rotation and deferred-rotation pastures (tables 1 and 2). There was a 3.5-fold increase of grass production in the grazed portion and only a 1-fold increase in the ungrazed portion of rest-rotation pastures.

The deferred-rotation system showed the largest increase in grass production. In the grazed portion there was a 4.4-fold increase compared to 1.6-fold in the ungrazed portion. Production on the grazed area in 1975 was 555 lb/acre (622 kg/ha) compared to 3,011 lb/acre (3372 kg/ha) in 1981.

The nongrazed pastures also contained fenced and unfenced plots although neither was grazed except by mule deer and elk. The unfenced plots had a 3.6-fold increase while the fenced plots had a 5.6-fold increase of grass production (tables 1 and 2).

It appears the vegetative response of the grazed plots in the deferred-rotation and rest-rotation systems were similar to the control in the nongrazed system. However, the ungrazed plots, regardless of grazing system (with the exception of the short-duration, high-intensity pastures), did not follow the

response in the ungrazed pastures (tables 1 and 2). One explanation is nonuniformity of plant communities. That, of course, is one of the reasons the split plot design was implemented. It was easier to measure changes in vegetative response to treatments on homogeneous plant communities within pastures than to extrapolate plant community response from other pastures.

This problem should be considered when designing monitoring systems and research programs for riparian areas. Plant communities in riparian areas are not so discrete nor as large as those occurring in forest and rangeland plant communities. Not only are riparian communities smaller but they occur more as a continuum making identification more difficult.

Forb response to protection and grazing was erratic with increases and decreases occurring in both grazed and ungrazed plots within pastures (tables 1 and 2). There was, however, a trend toward decreasing forb production with deferred rotation and short-duration, high-intensity systems.

When forb and grass production in both grazed and ungrazed plots were combined, large

Table 1.--Grass and forb production response by grazing systems from 1975 through 1981 (lb/acre).

Vegetative class	1975					1981				
	SL	DR	RR	SDHI	NG	SL	DR	RR	SDHI	NG
Grasses	1570	555	243	447	461	3489	3011	1103	1779	2127
Forbs	279	511	265	523	170	605	353	455	259	202

SL = Season-long grazing  
 DR = Deferred grazing  
 RR = Rest-rotation grazing  
 SDHI = Short-duration, high-intensity  
 NG = No grazing, control pasture

Table 2.--Grass and forb production response from nongrazing from 1975 through 1981 (lb/acre).

Vegetative class	1975					1981				
	SL	DR	RR	SDHI	NG	SL	DR	RR	SDHI	NG
Grasses	843	1056	759	394	271	1897	2766	1517	1645	1798
Forbs	480	288	369	401	339	315	401	882	706	461

increases in plant biomass production were obvious. With the exception of short-duration, high-intensity grazing, all other grazing systems produced almost twice as much herbage as the ungrazed plots (table 3). With vegetation responding this dramatically to grazing treatment and the objective being improvement of biomass production in the riparian area, it appeared that this can best be accomplished or accelerated with grazing instead of protection.

Table 3.—Net changes in total production between grazing and ungrazed plots from 1975 through 1981 as a percentage.

	SL	DR	RR	SDHI	NG
Ungrazed (fenced)	67.2	135.6	112.7	195.7	270.3
Grazed (unfenced)	121.4	215.6	206.7	110.1	269.1

The annual fluctuation of precipitation certainly has compounding effects on herbage production. What these effects have been, either annually or cumulatively on production response of floodplain vegetation in this study, were undetermined. Weather data collected on the study site indicated, as a whole, above average precipitation (for the surrounding area) during the study period. In 1977 there was, however, below average precipitation. On the other hand, because of soil and moisture conditions found in the riparian area, production response to annual precipitation may be negated. Although this is a pitfall in vegetation production research, there is also no way to control this variable.

#### CONCLUSION

In this study, productivity of riparian zone and floodplain vegetation was rapidly

enhanced when no more than 70 percent of the herbage was removed annually. And, in the case of the floodplain, vegetative production was accelerated with grazing.

The riparian area is complex and proper management is critical. The aquatic system, riparian zone, and floodplain areas may react more or less independently of one another. Because the riparian area is disproportionately important to a variety of users, conflicts are sure to arise and acceptable solutions are difficult. I believe cooperation and coordination between user groups are preferable to conflict and apt to provide better, longer lasting answers.

When developing management plans for the riparian areas, it is important to identify limiting factors before establishing the objectives. Approaches can be unnecessarily expensive and, sometimes, socially and economically inappropriate.

#### LITERATURE CITED

- Buckhouse, John C., Robert W. Knight, and Jon M. Skovlin. 1979. Some erosional and water quality responses to selected animal grazing practices in northeastern Oregon. *In Proc. of the Oregon Academy of Science Volume XV*, p. 13-22. Corvallis, Oregon.
- Driscoll, R. S. 1955. A guide to the Starkey Experimental Forest and Range, USDA Forest Service, Pacific Northwest Forest and Range Experiment Station, Portland, Oregon. 21 p.
- Ganskopp, D. C. 1978. Plant communities and habitat types of the Meadow Creek Experimental Watershed. M.S. thesis, Oregon State Univ., Corvallis, Oregon. 151 p.
- Strickler, G. S. 1965. Soil and vegetation on the Starkey Experimental Forest and Range. *Soc. Amer. For. Proc.* 1965:27-30.

# Grazing Management Influences on Two Brook Trout Streams in Wyoming<sup>1</sup>

Wayne A. Hubert<sup>2</sup>, Robert P. Lanka<sup>3</sup>,  
Thomas A. Wesche<sup>4</sup>, and Fred Stabler<sup>5</sup>

---

Abstract.--Brook trout abundance and instream habitat characteristics were evaluated in two rangeland streams. Heavily grazed and lightly grazed reaches of two streams with different grazing management were compared. Relationships between stream morphology, riparian zone characteristics, and trout abundance were observed.

---

## INTRODUCTION

The impacts of cattle grazing in riparian zones of small western streams on trout habitat quality and trout abundance have been described by numerous authors, but published accounts of case histories are not abundant (Gunderson 1968, Lorz 1974, Marcuson 1977). The rate of trout habitat deterioration under varying grazing intensities and the degree of grazing that can be experienced without impact on trout habitat are poorly understood.

The most common management alternative employed to renovate grazing-impacted riparian areas and stream habitats is enclosure of cattle by fencing (Platts and Wagstaff 1984). Observations on rangeland trout stream habitat changes in response to fencing have been made by Claire and Stork (1977), Stork (1979), Duff (1977, 1979), Keller et al. (1979), Dahlem (1979), Van Velson (1979), and Platts (1981a, 1981b, 1981c). In general, with cessation of heavy grazing the stream channel narrows and deepens, pool development is accentuated, stream banks stabilize with establishment of vegetation, and greater

overhead cover forms (Bowers et al. 1979). Two rangeland brook trout (*Salvelinus fontinalis*) streams in Central Wyoming that have been influenced by grazing over several decades provided an opportunity to assess two aspects of riparian zone grazing management. Past management of Pete Creek enabled a comparison of trout habitat quality in stream reaches grazed by cattle for many years with reaches grazed by horses, wildlife and a few cattle. Cherry Creek had been grazed by cattle, but two riparian-area exclosures constructed in 1980 reduced cattle grazing over a portion of the stream, enabling assessment of trout habitat response to reduced grazing intensity.

Pete Creek and Cherry Creek are adjacent similar watersheds located on the north side of the Ferris Mountains (T27N, R88W) in the North Platte River Basin approximately 70 km north of Rawlins, Wyoming. The water source for the creeks consists of numerous mountain springs. The upper end of the watersheds (3,000 m elevation) is steep with conifers, shrubs, and grasses on the slopes. As the streams descend from the mountains, the gradient decreases and the watershed is dominated by shrubs and grasses. The riparian area contains woody vegetation, primarily willows (*Salix* spp.). The average frost-free period in the study area is 90 days with an average annual precipitation rate of 30 cm, mostly in the form of winter and spring snow. Within the study area, both streams had low gradients (mean = 2.2% for Pete Creek, 2.9% for Cherry Creek) and the average elevation was 2,000 m.

Both streams were under multiple-use management by the United States Bureau of Land Management (BLM). In addition to grazing, the streams were used for recreation (fishing, hunting, camping). The fisheries were exclusively brook trout (*Salvelinus fontinalis*) of a relatively small size (<250 mm total length).

---

<sup>1</sup>Paper presented at Riparian Ecosystems and Their Management: Reconciling Conflicting Uses. First North American Riparian Conference, Tucson, Arizona, April 16-18, 1985.

<sup>2</sup>Wayne A. Hubert is Assistant Leader, Wyoming Cooperative Fisheries and Wildlife Research Unit, University of Wyoming, Laramie, Wyoming. The Unit is jointly supported by the University of Wyoming, the Wyoming Game and Fish Department, and the United States Fish and Wildlife Research Unit.

<sup>3</sup>Robert P. Lanka is Research Assistant, Wyoming Cooperative Fisheries and Wildlife Research Unit.

<sup>4</sup>Thomas A. Wesche is Watershed Specialist, Wyoming Water Research Center, University of Wyoming, Laramie, Wyoming.

<sup>5</sup>Fred Stabler is Fisheries Biologist, United States Bureau of Land Management, Rawlins, Wyoming.

Pete Creek enabled assessment of the influence of a long period (>25 years) of cattle grazing on trout stream habitat. The study area was on BLM rangeland where a grazing allotment had been fenced into a large cattle pasture and a smaller horse pasture. The fence ran parallel to the general direction of Pete Creek and separated meanders of the stream into the two pastures. The cattle pasture was grazed between June and October each year. As many as 500 cattle would concentrate on <20 hectares of riparian area (2.5 km long) at some times in the cattle pasture. Obvious impacts included an almost total lack of woody vegetation, as well as numerous bare and eroding banks. The horse pasture was grazed by horses, wildlife, and occasionally a few cattle. The riparian area within the horse pasture contained dense willow growth and the stream banks were heavily vegetated with little evidence of bare or eroding areas.

The influence of a 4-year old exclosure on the riparian area of Cherry Creek, a grazed rangeland was assessed. The Cherry Creek study area was a BLM allotment (15,300 ha) which had 4,800 animal-unit-months of grazing, between May 10 and October 10 for at least 25 years. A habitat management plan was developed by the BLM in cooperation with the Wyoming Game and Fish Department in 1979. The plan responded to the BLM's directive to initiate stream improvement and to recognize livestock manipulation as a management tool. Subsequently, two exclosures were constructed over 6.4 km of the stream and completed in 1980. A 100 m-long water gap was left between the two exclosures. Since 1980 some grazing has occurred within the exclosures by wildlife and trespass cattle.

#### Methods

Selected 75-m-long reaches of each creek were assessed during Summer 1984. Within each stream reach the abundance of brook trout was estimated and several stream habitat variables were measured. Trout abundance (kg/km) was determined by electrofishing using a three-pass removal-depletion technique (Platts et al. 1983). The Zippin (1958) method for computing the estimate was used.

Stream habitat conditions were measured across transects at 7.5-m intervals over the reach. At one-quarter, one-half and three-quarters the width of the stream the substrate and water depth were measured. Substrate was ocularly classified as silt-sand, gravel, rubble or boulder according to the criteria of Duff and Cooper (1978). The width at each transect was measured, as well as the linear distance of overhanging bank cover (Wesche 1980) and overhanging vegetative cover. Overhanging vegetation was defined as vegetation which extends at least 15 cm over the stream and shades the water at mid-day. The area of the reach shaded between 1000 and 1400 hours was estimated by measuring the linear distance shaded on each transect and computing the percentage of cumulative measured width covered by shade.

Over each study reach the Stream Reach Inventory Channel Stability Index was computed (Phankuck 1975). The quality of the three uppermost pools in each reach was rated (Duff and Cooper 1978). Ten, 5-m transects at right angles from the stream, at 7.5-m intervals on alternating sides of the stream, were measured in each reach to determine the amount of bare soil and litter in the riparian zone immediately adjacent to the stream using the line intercept method. The percentage of the total transects distance covering bare ground or litter was used as the estimator.

## Results and Discussion

### Pete Creek

Three study reaches were assessed within each pasture on Pete Creek. The abundance of brook trout varied with the reaches in the cattle pasture having a mean density of 8.0 kg/km (0.0 - 12.6 kg/km range). The reaches in the horse pasture had densities of 116.4 and 65.6 kg/km in the upstream areas, but only 10.0 kg/km in the lowest reach. The lowest reach was downstream from a long reach in the cattle pasture where overhanging vegetation was totally lacking and the stream channel was wide and shallow. It is expected that water temperature increased through this reach and negatively impacted downstream brook trout.

Several stream habitat variables showed a statistically significant ( $p < 0.05$ ) difference between the cow pasture and the horse pasture (Table 1). Stream reaches in the horse pasture were narrower and deeper, had more variation in depth, and had deeper pool and run areas. In addition, these reaches had greater quantities of overhanging bank cover, overhanging vegetation, and shaded area. The combination of deeper, narrower stream reaches with overhanging cover and shade indicated a much better habitat for brook trout in the lightly grazed reaches than in the cow pasture (Bowers et al. 1979).

### Cherry Creek

Eight stream reaches were evaluated on Cherry Creek: two upstream from the exclosures, two within each of the two exclosures, and two downstream from the lower exclosure. The riparian area inside and outside the exclosures had substantial woody vegetation (*Salix* spp.). Several cottonwoods (*Populus* spp.) occurred within the exclosures, but were absent outside. Bare banks along the stream were evident outside of the exclosures.

The average biomass of brook trout inside (30.1 kg/km) and outside (28.3 kg/km) the exclosures was similar. Biomass estimates ranged from 12.1 to 56.3 kg/km with the lowest and highest estimates occurring in reaches outside the exclosure.

Several stream habitat characteristics showed a statistically significant difference between reaches inside and outside the exclosures (Table 2). Stream reaches inside the exclosures were narrower and deeper, and had more pool and run area >22 cm deep. Within the exclosures there was significantly less bare soil and litter along the stream banks, as well as less silt on the stream bottom. No pre-exclosure data are available. It is possible the differences in channel morphology between reaches inside and outside the exclosures existed prior to fencing, and our results should be interpreted with this in mind.

While trout population responses have been observed in several streams following construction of exclosures (Platts and Wagstaff 1984) no difference in brook trout abundance was observed between reaches of Cherry Creek inside and outside the exclosure. This may be because the stream habitat had not been highly degraded prior to exclosure construction, little change in habitat quality has occurred inside the exclosures since 1980, or fishing pressure being greater inside the exclosure. Our data indicated reaches outside the exclosure of Cherry Creek had not been as severely impacted as the portions of Pete Creek inside the cattle pasture. Reaches of Pete Creek within the horse pasture had 3-4 times more fish, were narrower and deeper, and had more overhanging more bank cover, overhanging vegetation, and shaded area (Tables 1 and 2).

In Cherry Creek, differences in channel morphology, substrate composition, and vegetative cover along the stream banks were observed after four years within stream reaches where exclosures prevented cattle grazing; but measurable differences in trout cover and trout abundance were not observed. Responses associated with recovery of woody vegetation (overhanging vegetative cover and shade) may require 8-10 years to show up (Duff 1979, Richard and Cushing 1982). Our observations suggest that a quick response in riparian vegetation will not always result in rapid fishery benefits.

#### General Trends

The sampled stream reaches of Pete Creek and Cherry Creek represented a range of grazing intensity, thereby enabling the influence of grazing intensity on stream habitat characteristics and brook trout abundance to be assessed. Correlations (n=13) between measured habitat variables and trout abundance were significant for average width ( $r = -0.527, p = 0.032$ ), average depth ( $r = 0.671, p = 0.006$ ), width-depth ratio ( $r = -0.580, p = 0.019$ ), proportion of stream with water depth exceeding 22 cm ( $r = 0.48, p = 0.045$ ), and pool rating ( $r = -0.531, p = 0.031$ ), as well as percent rubble substrate ( $r = -0.541, p = 0.028$ ). The data from Pete Creek and Cherry Creek (Tables 1 and 2) indicated that statistically significant habitat variables, with the exception of rubble substrate, respond to grazing intensity.

Correlations between the habitat variables associated with trout abundance and other riparian zone characteristics responsive to cattle grazing indicated the influence of cattle on trout. The abundance of riparian shrubs, overhanging vegetation, and overhanging bank cover in the study reaches of Pete Creek and Cherry Creek were correlated ( $p < 0.05$ ) with instream habitat variables (depth and pool quality) that influence brook trout abundance. Grazing and bank trampling by cattle impact these riparian zone features with a subsequent effect on instream habitat and trout abundance. The Pete Creek and Cherry Creek cases illustrated the impacts of long-term cattle grazing on brook trout streams in Central Wyoming, and further indicated that the response of trout habitat to cattle exclusion is not rapid for these streams.

Table 1.--Mean values of stream habitat variables measured in heavily and lightly grazed reaches of Pete Creek in 1984 (\*indicates statistically significant difference at  $p < 0.05$ , \*\*indicates difference at  $p < 0.10$ ).

Variable	Mean Value (n = 3)	
	Heavily Grazed	Lightly Grazed
Width (m)	2.9	2.2 *
Depth (m)	0.07	0.11 *
Width/depth ratio	43	21
Coefficient of variation in depth	47.3	66.6 *
%greater than 22 cm deep	9.0	22.3 **
%silt substrate	35	52
%gravel substrate	35	31
%rubble substrate	24	14
%bedrock-boulder substrate	1	3
SRI/CSI	112	110
%overhanging bank cover	2.7	30.0 *
%overhanging vegetation	0.0	11.7 *
%shaded area	0.7	18.3 *
%bare soil along banks	19.7	13.3
%litter along banks	7.0	6.0



Table 2.--Mean values of stream habitat variables measured inside and outside exclosures on Cherry Creek in 1984 (\*indicates statistically significant difference at  $p \leq 0.05$ ).

Variable	Mean Value (n = 4)	
	Outside Exclosure	Inside Exclosure
Width (m)	2.9	2.5 *
Depth (m)	0.08	0.09 *
Width/depth ratio	37	28 *
Coefficient of variation in depth	57	71
%greater than 22 cm deep	6.7	21.0 *
%silt substrate	22	13 *
%gravel substrate	23	20
%rubble substrate	39	48
%bedrock-boulder substrate	16	20
SRI/CSI	111	93
%overhanging bank cover	24.0	15.3
%overhanging vegetation	8.5	18.0
%shaded area	23.5	28.0
%bare soil along banks	22.8	12.3 *
%litter along banks	10.0	6.8 *

#### LITERATURE CITED

- Bowers, W., B. Hosford, A. Oakley and C. Bond. 1979. Wildlife habitats in managed rangelands--The Great Basin of Southeastern Oregon. Native Trout. USDA Forest Service General Technical Report PNW-84. 16 p. Pacific Northwest Forest and Range Experiment Station, Portland Ore.
- Claire, E.W., and R.L. Stork. 1977. Streamside management and livestock grazing in the Blue Mountains of Oregon: A case study. p. 111-128 *In Proceedings of the workshop on livestock and wildlife-fisheries relationships in the Great Basin.* [Sparks, Nev., May 3-5, 1957] Special Publication 3301.
- Dahlem, E.A. 1979. The Mahogany Creek watershed--with and without grazing. p. 31-34 *In Proceedings of the forum--grazing and riparian/stream ecosystems.* [Denver, Colorado, November 3-4, 1978] Trout Unlimited Inc., Vienna, Vir.
- Duff, D.A. 1977. Livestock grazing impacts on aquatic habitat in Big Creek, Utah. p. 129-142. *In Proceedings of the workshop on livestock and wildlife-fisheries relationships in the Great Basin.* [May 3-5, 1977, Sparks, Nev.] Special Publication 3301.
- Duff, D.A. 1979. Riparian habitat recovery on Big Creek, Rich County, Utah--a summary of 8 years of study. p. 91-92. *In Proceedings of the forum--grazing and riparian-stream ecosystems* [Denver, Colorado, November 30, 1978] Trout Unlimited Inc., Vienna, Vir.
- Duff, D.A., and J.L. Cooper. 1978. Techniques for conducting stream habitat surveys on national resource land. USDI Bureau of Land Management Technical Note 283.
- Gunderson, D.R. 1968. Floodplain use related to stream morphology and fish populations. *Journal of Wildlife Management* 32:507-514.
- Keller, C., L. Anderson, and P. Tappel. 1979. Fish habitat changes in Summit Creek, Idaho after fencing. p. 39-45. *In Proceedings of the forum--grazing and riparian/stream ecosystems.* [Denver, Colorado, November 3-4, 1978] Trout Unlimited Inc., Vienna, Vir.
- Lorz, H.S. 1974. Ecology and management of brown trout in Little Deschutes River. Fisheries Research Report 8. 48 p. Oregon Department of Fish and Wildlife, Portland, Ore.
- Marcuson, P.E. 1977. The effect of cattle grazing on brown trout in Rock Creek, Montana. Project Number F-20-R-21-11-a. 26 p. Montana Department of Fish and Game, Helena, Mont.
- Phankuck, D.J. 1975. Stream reach inventory and channel stability evaluation. USDA Forest Service, Northern Region, Missoula, Mont.
- Platts, W.S. 1981a. Effects of livestock grazing. USDA Forest Service General Technical Report PNW-124. 25 p. Pacific Northwest Forest and Range Experiment Station, Portland, Ore.
- Platts, W.S. 1981b. Effects of sheep grazing on a riparian-stream environment. USDA Forest Service Research Note INT-307. Intermountain Forest and Range Experiment Station, Ogden, Utah.
- Platts, W.S. 1981c. Impairment, protection, and rehabilitation of Pacific salmonid habitats on sheep and cattle ranges. p. 82-91. *In Proceedings: protection, enhancement, and rehabilitation of anadromous salmonid populations and habitat in the Pacific Northwest symposium.* Humboldt State University, Arcata, Calif.
- Platts, W.S. and F.J. Wagstaff. 1984. Fencing to control livestock grazing on riparian habitats along streams: is it a viable alternative? *North American Journal of Fisheries Management* 4:266-272.
- Platts, W.S., W.F. Megahan, and G.W. Minshall. 1983. Methods for evaluating stream, riparian, and biotic conditions. USDA Forest Service General Technical Report INT-138. 70 p. Intermountain Forest and Range Experiment Station, Ogden, Utah.
- Richard, W.H. and C.E. Cushing. 1982. Recovery of streamside woody vegetation after exclusion of livestock grazing. *Journal of Range Management* 35(3):360-361.

- Storch, R.L. 1979. Livestock/streamside management programs in Eastern Oregon. p. 56-59. In Proceedings of the forum--grazing and riparian/stream ecosystems. [Denver, Colorado, November 3-4, 1978] Trout Unlimited Inc., Vienna, Vir.
- Van Velson, R. 1979. Effects of livestock grazing upon rainbow trout in Otter Creek, Nebraska. p. 53-55. In Proceedings of the forum--grazing and riparian/stream ecosystems. [Denver, Colorado, November 3-4, 1978] Trout Unlimited Inc., Vienna, Vir.
- Wesche, T.A. 1980. The WRRRI trout cover rating method. Development and application. Water Resources Series No. 78. Water Resources Research Institute, University of Wyoming, Laramie, Wyoming.
- Zipin, C. 1958. The removal method of population estimation. Journal of Wildlife Management 22(1):82-90.

# Livestock Grazing Effects on Southwestern Streams: A Complex Research Problem<sup>1</sup>

John N. Rinne<sup>2</sup>

---

Abstract.--Conducting viable research on the effects of domestic livestock grazing on stream environments and biota in southwestern National Forests is problematic. The multiple-use concept, spatial temporal factors, inadequate control and replication, and changes in land management objectives and direction render it difficult to effectively study grazing impacts.

---

## INTRODUCTION

National Forest lands cover about 21 million acres in Arizona and New Mexico. These lands are typically upper elevation (>1,500 m) and are the coolest and best-watered areas in the predominantly arid Southwest. Because of the greater annual precipitation, extensive, harvestable stands of conifer forests flourish. Livestock graze on herbaceous forage over more than 75% of all forest lands in the western states. In these upland, more mesic areas, streams support both wild and put-and-take populations of trout and other native fishes.

Until recently, most studies relating the interactions of grazing and fisheries have been descriptive, popularized, and have lacked scientific approach and proper study design (Platts 1982). Accordingly, the effects of domestic livestock grazing on stream habitat, water quality, and fish populations are little known and often misinterpreted. Grazing and stream habitat/fisheries interactions have become the topic of increased research in the last decade, but most effort has been in the northern Rocky Mountains and Great Basin states (Kauffman and Krueger 1984).

In 1982, research was initiated on a montane stream in northern New Mexico that was previously fenced to exclude domestic livestock. The objective of the study was to determine if removal of grazing was beneficial to stream habitat and fisheries. Preliminary data have been acquired on fishes and their habitat on this stream and several nearby streams draining

watersheds that have been either subjected to or restricted from multiple use management.

Results so far have not been what we anticipated. The purpose of this paper is neither to present startling results, nor to admit defeat. The purpose is to point out the complexity of the relationships that must be studied in riparian habitats. Managers cannot expect quick, broad-scale solutions to resource use conflicts, and researchers must be exceedingly perceptive in how they design their studies if they are to provide meaningful results.

## STUDY AREA DESCRIPTION

Two disjunct study areas were examined. The first, the Rio de las Vacas, is a third order montane stream draining the San Pedro Parks Wilderness Area, Santa Fe National Forest, New Mexico. Descriptions of this study area and livestock grazing history are given in Szaro et al. (1985). The other, the Santa Fe River, is a second-order stream in the Sangre De Cristo Mountains of northern New Mexico. It serves as the primary water supply for the city of Santa Fe. Its lower reaches are bounded by Public Services (a water utility) property and its upper reaches are on the Santa Fe National Forest. To insure high water quality, the watershed has been closed to normal multiple uses since the 1930's. The stream is impounded by a series of water storage reservoirs on the lower public utilities land. The Rios Nabe and Capulin head on the same mountain as the Santa Fe River, but drain north-northwest on its opposite side. Both watersheds are subject to normal National Forest multiple uses. Steep mixed conifer slopes border all three streams.

The Rio de las Vacas supports three native and at least two introduced species of fishes. The Rio Grande sucker (*Pantosteus plebius*) and Rio Grande chub (*Gila pandora*) along with the Rio Grande cutthroat trout (*Salmo clarki virginalis*)

---

<sup>1</sup>Paper presented at the Symposium, Riparian Ecosystems and Their Management: Reconciling Conflicting Uses. [Tucson, Arizona, April 16-18, 1985].

<sup>2</sup>John N. Rinne is Research Fisheries Biologist, USDA Forest Service, Arizona State University Campus, Tempe, Arizona.

occur naturally in the stream. Brown trout (*Salmo trutta*) and rainbow trout (*S. gairdneri*) have been and are continually being introduced into the stream. The rainbow hybridizes with the native cutthroat. The Santa Fe River and Rios Nambe and Capulin contain both native cutthroat and introduced rainbow trout and their hybrids. All streams but the Santa Fe River are subject to sport fishing.

#### METHODS

Fish numbers and biomasses were estimated by blocking 50-m sections of stream and electrofishing each section three times (Rinne 1978). Initially, six 50-m sections were established in the upstream enclosed (ungrazed) reaches of the Vacas and four in the downstream non-exclosed (grazed) area (fig. 1). Water quality was analyzed by means of a portable Hach field water quality kit, streambank stability was estimated following methods of Binns (1982), and streambank vegetation and overhanging vegetation were measured with a meter tape and expressed as percentage of streambank. Fine content of the substrate was estimated by a modified Mark IV Standpipe corer.

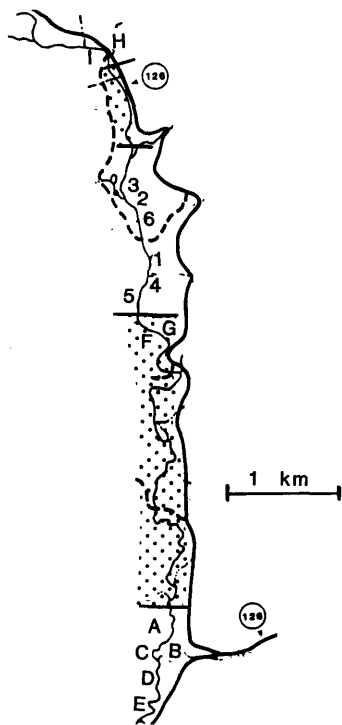

Figure 1.--Detailed map of the Rio de las Vacas indicating study sections within grazing exclosures (1-6) and those in grazed areas (A-I). Stippled area indicates where the stream passes through private lands.

Table 1.--Comparative physical habitat of study sections in ungrazed (1-6) and grazed (A-F) reaches of the Rio de las Vacas

Study section	Streambank vegetation (%)	Overhanging vegetation (%)	Bank instability (%)
1	24.00	17.4	0
2	11.03	56.0	0
3	2.00	33.5	0
4	13.00	5.3	0
5	0.00	2.0	0
6	0.00	0.0	0
Mean	8.38	17.2	0
A	6.00	0.0	100
B	0.00	0.0	74
C	0.00	0.0	80
D	0.00	0.0	80
E	0.00	0.0	30
F	0.00	0.0	20
Mean	1.00	0.0	64

#### RESULTS AND DISCUSSION

Physical habitat structure in the Rio de las Vacas was dramatically different between grazed and ungrazed reaches of stream (table 1). Streambank vegetation and overhanging vegetation were much greater in the enclosed compared to the non-exclosed reaches. Bank instability varied from 20 to 100% in the grazed areas and averaged 64% overall. Banks were totally stable in the enclosed areas.

In 1982, fish abundance in the Vacas was highly variable (table 2). In the ungrazed area, 86 to 95% of total numbers of fish and 51 to 75% of total biomass were comprised of suckers and chubs. By comparison, these two taxa contributed 95% or more of total number and biomass in the grazed area. Chubs and brown trout were inversely abundant within and outside exclosures. Overall, numbers of fish were greater in the grazed area, but biomass was greater in the ungrazed area, reflecting larger mean size of fish in the enclosed study sections.

Subsequent examination of fish populations in summers of 1983 and 1984 (data not presented here) revealed a dramatic decrease in total numbers and biomass of fish per 50-m section in both the grazed and ungrazed areas. In contrast, overall numbers and biomasses of salmonids generally increased between 1982 and 1984 in all study sections in the grazed area and in half the sections in the ungrazed areas. These data basically contradict reasonable fish habitat relationships (tables 1, 2), and immediately suggest other factors may be altering or concealing suspected functioning of the stream ecosystem under protection from grazing. Several factors are immediately suspect.

First, although structurally a stream is a discretely defined, narrow band of habitat situated in the overall landscape, functionally, it is not so simplistic or easily defined. Streams are dynamically interrelated with their watersheds (Hynes 1975, Platts 1979, Triska et al. 1982). A given reach is not independent, but affected by reaches both up- and downstream (Vannote et al. 1980). The marked bank instability that logically should negatively impact fish populations in grazed reaches of the Vacas may be mitigated to some degree by the two upstream exclosures containing stable streambanks. In like manner, the improved streambank and riparian condition in the exclosed reaches are affected by riparian and watershed conditions upstream that have been impacted not only by domestic livestock grazing, but by other multiple uses. In context of the river continuum concept, 2 km of apparently enhanced streambank and riparian condition are most likely either not sufficient to positively influence fish populations, or positive influences are being mitigated or masked by contiguous negative influences.

Several other important factors that fall under the umbrella of "biological influence" are likely contributors to the atypical fish population structure in the grazed and ungrazed areas. First, although the Vacas contains both salmonid and non-salmonid fishes, the majority of the numbers and biomass is in suckers and chubs (table 2). Any estimation of the impact on the fishery resource is therefore largely an estimation of the effect that grazing potentially has on non-salmonid fishes. Then consider that a critical life history stage in any biological entity is its reproductive stage. Increased fines in substrates affect not only fish spawning success (Saunders and Smith 1965) but also their food base, aquatic macroinvertebrates (Chutter 1969). Increased silt load in the streambed

interstices reduces not only living space for aquatic insects, but also water flow and resultant dissolved oxygen levels of water within the streambed. Based on permeability estimates, fines in the channel substrate were only slightly higher on an average in the grazed areas. The Rio Grande sucker and Rio Grande chub most likely spawn on the substrate surface (Reigard 1920), while trout deposit spawning products below the surface in redds. In addition, the tolerance of the native sucker and chub to increased silt load and lower O<sub>2</sub> levels is most likely greater than that of the salmonids (Hoar and Randall 1970:273). Perhaps, therefore, we should not expect any differences in fish populations between the grazed and ungrazed reaches of stream.

Second, normal fluctuations in fish populations also affect interpretations of grazing effects on fishes, especially in this brief (3 years) frame of reference. Between the 1982 and 1984 sampling periods, non-salmonids decreased in 75% of study sections. In contrast, brown trout decreased in all study sections in the exclosed areas, but increased in all but one study section in the grazed areas. The rainbow-cutthroat hybrid group increased in 90% of all study sections during this same time period. These fluctuations lack any logical pattern, and certainly make it difficult or impossible to interpret the effect of grazing on fish populations.

The differential management of salmonids versus non-salmonids is a factor that certainly must contribute to the lack of pattern in fish populations. Casual analysis of the impact of stocking and sport fishing in the Vacas demonstrates this potential effect. Between 1 July 1982 and 30 June 1983, 9,000 catchable rainbows were stocked in the Vacas from the nearby Seven Springs Hatchery. In addition, 800 brown trout were stocked in September 1982. Detailed creel census records were unavailable, but in 1981, estimated fisherman days on the Vacas were 9,051 and catch was 21,855 trout. Even these spotty data, in context of the estimated low numbers of salmonids in the Vacas (table 2), suggest attempting to relate trout numbers and biomasses to grazing effects in the Vacas is problematic at best.

Third, interspecific interactions likewise must affect fish populations in the Vacas. Observations while electrofishing suggest that undercut banks and pools with large numbers of brown trout had fewer chubs, which also select for this type of habitat. Brown trout are highly piscivorous, and the 800 stocked in September 1982 certainly may, in part, be responsible for the general reduction in native chubs and conceivably even suckers between 1982 and 1984.

Finally, mobility of fish populations also has to be considered in any exclosure study. Tag-recovery data indicate that sucker and chub populations are moderately to very mobile, and fish reared in ungrazed reaches of stream certainly may become part of the biomass estimates in ungrazed reaches, and vice versa.

Table 2.--Summary of fish numbers and biomass (parentheses) in 10 50-m sections of the Rio de las Vacas, summer 1982. Biomasses are in grams. Sections 1-6 denote ungrazed reaches and A-D grazed sections

Section	Rio Grande sucker	Rio Grande chub	Brown trout	Hybrid	Total
1	51(1,630)	33(354)	8(646)	2(118)	94(2,748)
2	93(1,116)	27(267)	7(328)	3(123)	130(1,834)
3	135(1,124)	53(714)	17(710)	5(191)	210(2,739)
4	63(750)	66(756)	7(1,317)	0(0)	136(2,823)
5	123(1,279)	26(322)	9(1,540)	1(10)	159(3,151)
6	114(1,695)	51(739)	13(1,305)	3(118)	181(3,857)
A	86(502)	55(394)	0(0)	0(0)	141(896)
B	261(1,871)	281(2,905)	2(62)	1(208)	545(5,046)
C	174(828)	128(735)	0(0)	0(0)	302(1,470)
D	217(1,287)	207(1,088)	2(23)	5(8)	431(2,046)

Platts (1982) suggests that study design is a major factor in reducing reliability of data in grazing-fisheries studies. Land ownership in this study area demonstrates the effect of differential land ownership and management as a barrier to proper study design (fig. 1). Because private land was positioned immediately up- and downstream from the two exclosures, sample sections in the exclosed areas (1-6) initially were distant from those established in downstream non-exclosures (A-E) on National Forest lands. In 1983, permission was obtained to sample reaches of stream on private land immediately below the exclosures. Two additional study sections (F, G) were placed here in 1983, and two more (H, I) were placed upstream from the exclosures (fig. 1) in 1984. Estimated fish numbers in 1984 in the contiguous grazed sections (F-I) versus the non-contiguous sections (A-E) demonstrate the possible influence of space on appraisal of grazing-fisheries interactions. The upper ungrazed (exclosed) sections ranged from 73 to 126 fish (mean 91) per 50-m section, and the upper, more contiguous grazed sections (F-I) ranged from 62 to 104 fish (mean 86). By comparison, the lower grazed sections (A-E) ranged from 133 to 356 (mean 225) fish per 50-m section. Numbers of fish in the distant downstream grazed area were markedly higher than those in not only the upper ungrazed reaches but the grazed reaches as well. These data suggest that the change in stream habitat in 4 km (fig. 1) in itself may have as much influence on fish populations as does domestic livestock grazing.

Another multiple use factor is recreational activity. Initially, water in an upper ungrazed reach (study section 3) was significantly higher in nutrients (phosphates, nitrates, and sulfates) than water in a downstream reach (section D) sampled the next day. Because of these differences additional samples were analyzed two days later from the upstream locality. Nutrients were no longer detectable, but hardness had increased significantly. The temporarily high level of phosphates, nitrates, and sulfates were very likely associated with observed heavy weekend recreational activity (23-24 June). Increased nutrient levels were not detected downstream the next day in the lower grazed area, perhaps because of rapid uptake by aquatic plants along the way and cessation of camping. Although stream nutrient levels may increase or decrease relative to grazing, periodic (weekly) recreational inputs of nutrients of this magnitude certainly must have an impact on the flora and fauna of the stream. Certainly, such inputs may mask detection of either the more subtle increases of nutrients from grazing (direct waste elimination) and naturally occurring breakdown of litter and debris, or from decreases resulting from plant and tree uptake.

In keeping with the idea that watershed management impacts a stream, data on fish populations were collected from three watersheds that have been managed differently for a considerable period of time (table 3). Estimated fish populations in study section 1 in the Santa Fe River were comparable between 1982-1983, but

Table 3.--Comparative fish numbers and biomasses in the Santa Fe River, and Rios Nambé and Capulín, 1982-1984

Stream	Year	Section	Number	Biomass (gr)
Santa Fe River	1982	1	40	1,052
		2	40	1,423
	1983	1	36	1,110
		2	57	2,786
Mean		43	1,593	
Rio Capulín	1983	1	50	1,092
	1984	1	38	1,340
		2	35	1,165
		3	19	801
Mean		36	1,100	
Rio Nambé	1983	1	37	1,117
	1984	1	23	1,626
		2	8	394
Mean		23	1,046	

increased 43% in numbers and 96% in biomass between years in section 2. Study section 1 in the Rio Capulín decreased about 25% in number of fish between 1983 and 1984, but, biomass increased 23% in the same time period. Number of fish in study section 1 decreased almost 40% from 1983 to 1984 in the Rio Nambé, but, biomass increased 46% during the same time period.

Point-in-time fish population estimates in the "quasi pristine" Santa Fe watershed were not significantly greater than in the Rios Nambé and Capulín, which are under normal multiple use management. The question of comparability of watersheds immediately arises. The three streams are relatively close--they head on the same mountain. However, geologic strata, watershed exposure, and vegetation may be different. The most obvious difference among the streams is that sport fishing is prohibited on the Santa Fe River, but occurs on the Rios Nambé and Capulín. One might therefore expect greater fish populations in the Santa Fe. Indeed, although average fish numbers and biomass in this stream were higher than in the other two streams (table 3), natural variation and sport fishing effects cannot be adequately defined in two years (Platts 1981).

#### RECOMMENDATIONS

Basic requirements of scientific research are control of variables in time and space, replication of experiments, and a valid research area. The case study on the Rio de las Vacas typifies the difficulty in achieving such control and replication on National Forest lands. A researcher's lack of ability to control the varying degree of multiple uses precludes determining the differential impacts of these respective uses. Differential management of

habitat and the sport fishery on these lands further complicates the situation. Presently, land use planning is a very essential and functioning component of the Resources Planning Act. However, studies that initially may have been well designed and conducted by the scientific method under one management plan, can be invalidated by a change in management direction. For example, despite the past lengthy closure of the Santa Fe watershed, the current draft Forest Plan for this area gives potential for opening the stream to multiple use management.

Possible solutions to the above dilemma are 1) to utilize existing experimental forests or 2) to designate areas solely for research, and manage these with only research in mind. In the Southwest, there are two experimental forests, Sierra Ancha and Fort Valley. Within these confines one theoretically should be able to control and design studies wherein management variables such as grazing can be controlled. These Forests, however, have been subjected to previous study and manipulation. Two of the three watersheds on the Sierra Ancha Experimental Forest have been experimentally manipulated (Rich et al. 1961).

As an alternative, specially designated areas (allotments or watersheds) on National Forest lands conceivably could provide areas for viable scientific examination of the effects of grazing on fish habitat and fisheries. These areas could function similar to the "Research Natural Area" concept. The recently acquired Valle Vidal in northern New Mexico is an example of such a potential research area. Within such a management framework, both short-term manipulative and reliable long-term research could be conducted.

The importance of long-term data for defining natural variability cannot be overstated. Research on a watershed deteriorated by domestic livestock grazing may require 10-20 years or even longer to begin to detect significant changes once a change in management direction is instituted. The present alternative to the controlled, long-term approach is to examine areas that have been differentially managed in a "case history approach." Such an approach has some merit, but normally will result in only descriptive, subjective results that will ask more questions than are answered. Realistically, such an approach will never delineate the interrelated processes that are functioning between a watershed subjected to domestic livestock grazing and an affected stream ecosystem and thus will not provide the land manager with reliable conclusions on which to base management decisions.

#### LITERATURE CITED

- Binns, N. A. 1982. Habitat quality index procedures manual. Wyoming Game and Fish Department, Cheyenne. 209 p.
- Chutter, F. M. 1969. The effects of silt and sand on the invertebrate fauna of streams and rivers. *Hydrobiologica* 34:57-76.
- Hoar, W. S., and D. J. Randall (eds.). 1970. *Fish physiology: Vol. 4. The Nervous System, Circulation, and Respiration*. Acad. Press, New York, New York. 532 p.
- Hynes, H. B. N. 1975. The stream and its valley. *Verhand. Internat. Verein. Limnologie* 19:1-15.
- Kauffman, J. B., and W. C. Krueger. 1984. Livestock impacts on riparian ecosystems and streamside management implications: A review. *J. Range Manage.* 37(5):430-437.
- Platts, W. S. 1979. Relationships among stream order, fish population, and aquatic geomorphology in an Idaho river drainage. *Fisheries* 4(2):5-9.
- Platts, W. S. 1982. Livestock and riparian-fishery interactions: What are the facts? *Trans. 47th North Amer. Wildl. and Nat. Res. Council:* 507-515.
- Reigard, J. 1920. The breeding behavior of suckers and minnows. *Biol. Bull., Wood's Hole Biol. Stn.* 38 p.
- Rich, L. R., H. G. Reynolds, and J. A. West. 1961. The Workman Creek watershed. USDA Forest Service, Research Paper RM-65. Rocky Mountain Forest and Range Experiment Station, Fort Collins, Colo.
- Rinne, J. N. 1978. Development of methods of population estimation and habitat evaluation for management of the Arizona and Gila trouts. p. 113-125. *In* J. R. Moring (ed.). *Proc. Wildl. Trout-Catchable Trout Symp.* Oregon Department of Fish and Game, Corvallis.
- Saunders, J. W., and M. W. Smith. 1965. Changes in a stream population of trout associated with increased silt. *J. Fish. Res. Bd. Canada* 27(2):395-404.
- Szaro, R. C., S. C. Belfit, J. K. Aitkin, and J. N. Rinne. 1985. A preliminary study on the impact of grazing on a high elevation population of wandering garter snakes. *Proc. Riparian Ecosystems Management Symposium.* [Tucson, Ariz., April 16-18, 1985].
- Triska, F. J., J. R. Sedell, and S. V. Gregory. 1982. Coniferous forest streams. p. 292-332. *In* Edmond, R. C. (ed.). *Analysis of Coniferous Forest Ecosystems in the Western United States.* US/IBP Synthesis Series 14, Stroudsburg, Pennsylvania.
- Vannote, R. L., G. W. Minshall, K. W. Cummins, J. R. Sedell, and C. E. Cushing. 1980. The river continuum concept. *Can. J. Fish. and Aqua. Sci.* 37:370-377.

# The Use of Cattle as a Management Tool for Wildlife in Shrub-Willow Riparian Systems<sup>1</sup>

Henry O. Krueger<sup>2</sup> and Stanley H. Anderson<sup>3</sup>

---

Abstract.--In high altitude shrub-willow riparian systems cattle can have a beneficial effect on wildlife by creating tunnels throughout the habitat. Mean tunnel heights for two study areas were 0.75 and 0.95 m with 41% of the shrubs sampled forming tunnels in each study area. These tunnels benefit birds and mammals by opening up willows which in turn increases the grassland habitat and structural diversity of vegetation.

---

## INTRODUCTION

Managers of riparian communities have often been caught in the middle of the controversy surrounding the impact of cattle grazing. Platts (1979, 1982) has given detailed reviews of this controversy and has reported how grazing can have deleterious effects on riparian vegetation, stream channels, streambanks, water quality, and fish populations. Roath and Krueger (1982) consider one of the major problems in the grazing of riparian systems as a dilemma between managing shrubs versus the management of herbaceous vegetation. However, as Platts (1985) has stated the proper grazing of streamside vegetation requires controlled animal distribution.

Few studies have been performed on the interaction of cattle with shrub-willow (*Salix* spp.) riparian systems in mountainous regions. Lorz (1974) conducted a fish study on the Little Deschutes River and found that the grazing of dense willow communities had no effect on fish populations when compared to ungrazed dense willow sites. Knopf and Cannon (1982) found that cattle altered the structure of shrub-willow riparian vegetation under different grazing systems in northcentral Colorado.

In high altitude (2438 m - 8000 ft) shrub-willow riparian systems of the North Platte River drainage cattle have a beneficial effect on small mammal and bird communities by creating and maintaining tunnels throughout the willow habitat. These tunnels are created by cattle busting out the lower branches of

willows and appear to provide access to the interior and lower portions of the shrubs, thus increasing structural diversity.

The major objectives of this study were 1) to document the extent of tunneling in a moderately grazed shrub-willow system as well as a system that has a history of overuse; 2) to determine shrub densities in both sites to see if grazing practices may have contributed to altered willow densities; and 3) to determine if bird species respond to willow densities.

## STUDY AREAS

This study was conducted over a three year period (1982-85) on two shrub-willow riparian communities located in the headwaters of the North Platte River drainage of southeastern Wyoming. Both sites were located in the mountains of the Medicine Bow National Forest and were dominated almost exclusively by shrub-willow species (*Salix* spp.) 0.5 m - 4.2 m high ( $\bar{x}$  = 2.0). Leafout of willows does not occur until early June in both sites. Leaves begin falling in late September or early October. Annual precipitation averages between 51 and 64 cm, most of which is in the form of snow. Snowpack exceeds three feet in both sites and livestock operations are strictly seasonal.

Pelton Creek (2535-2585 m): Two sites were established along this third order stream located in the Medicine Bow Mountains. The stream is bordered by dense willow stands dominated by *Salix geyeriana*. Sedges (*Carex* spp.) and grasses (Gramineae) also occur in the riparian zones interspersed with the willows. The drier upslopes are forested with lodgepole pine (*Pinus contorta*). The mid-level upslope areas between the willows and lodgepole are occupied by big sagebrush (*Artemisia tridentata*) and Idaho fescue (*Festuca idahoensis*).

---

<sup>1</sup>Paper presented at the symposium on riparian ecosystems and their management: reconciling conflicting uses. (Tucson, Arizona, April 16-18, 1985).

<sup>2</sup>Research Assistant, Wyoming Cooperative Research Unit, Dept. of Zoology and Physiology, Box 3166, University Station, Laramie, WY 82071.

<sup>3</sup>Unit Leader, Wyoming Cooperative Research Unit.



Big Creek (2430-2542 m): Three sites were located along this third order stream in the Sierra Madre Mountains. Two of these sites were located on the South Fork of Big Creek while the remaining site was located on the Middle Fork. These streams are bordered by moderately dense willow vegetation dominated by Salix geyeriana. Sedges and grasses were also interspersed with the willows. Upslopes are dominated by sagebrush (Artemisia tridentata) with some lodgepole and aspen (Populus tremuloides) stands on hillsides.

#### GRAZING HISTORIES

The grazing histories on the two study areas are quite different. Pelton Creek has a long history of season long and semi-deferred management systems. Records of the USDA Forest Service go back to the 1920's for Pelton Creek and show a continual decrease in the number of animal unit months (AUM's) allocated (1920's - 5,015 AUM's; 1940's - 2,000 AUM's; 1950 to 1967 - 1485 AUM's; and from 1967 to present - 300 head at 900 AUM's). Use at Pelton Creek has been less than or equal to permitted use. The season of use prior to 1957 was from 6 June to 30 September although permittees did not gain access until 1 July or later due to snowmelt. From 1957 to present the season of use has been from 1 July to 30 September. Distribution of cattle had been a problem in the past, but the permittee has used a full-time rider since the mid-70's who has kept the cattle in small groups which are regularly moved in the allotment. Range condition for this allotment has improved substantially since 1967 according to Forest Service reports. In addition to the rider, road traffic and fishermen also contribute to the movement of cattle.

All sites in the Big Creek drainage also have a long history of grazing, but range condition indicates past overuse (Forest Service report). The South Fork of Big Creek has just recently been acquired by the Forest Service who has initiated a deferred-rotation management system and also has implemented range improvements. Currently 714 yearlings are grazed for 1750 AMU's in the allotment with the season of use from 6 June - 30 September. In the deferred-rotation system the season of use has been divided into thirds.

#### METHODS

Sampling in each study site was conducted in the same manner as Knopf and Cannon (1982). The fundamental sampling units were willow shrubs which were defined as clumps of stems that exceeded 0.5 m in height. Sampling points were located using a systematic random design with stakes positioned at random distances from the stream at 50 m intervals. Each sampling point served as both a census stake and point from which random samples were selected. The shrub nearest the random point was used as the random sample. When censuses were conducted from these random points, shrubs in which sightings occurred were flagged and later sampled. Bird data collected from all three years of the study were used in the analysis.

From both randomly selected shrubs and shrubs in which sightings occurred, a point-centered sampling technique was used to estimate shrub density. Quadrants were designated as northwest, northeast, southeast, and southwest. A new measurement not recorded by Knopf and Cannon (1982), the tunnel height, was also recorded for each quadrant when appropriate. The tunnel height was defined as the height of open space between two shrubs when the shrubs were in contact with each other (intershrub distance = 0).

To determine if birds showed a preference for certain shrub densities, densities surrounding bird sightings and randomly located shrubs were compared. Preference was determined when mean densities from bird sightings were significantly different from random samples ( $P < 0.05$ ). Only species with sample sizes greater than ten were included in the analysis.

The number of sampling stakes in the two Pelton Creek sites were 50 and 70 for a combined total of 120 stakes. The number of stakes in the three Big Creek sites were 70, 22, and 15 for a combined total of 107 stakes. For the purpose of this paper all study sites were combined in each of the two study areas.

#### RESULTS AND DISCUSSION

Tunnel heights were recorded for all shrubs that had an intershrub distance of zero in the point-center quarter sampling scheme. The sample size for tunnel heights at Pelton Creek was 189 and at Big Creek 177. Of the quadrants searched in both study areas, 41% of the quadrant shrubs were in direct contact with the center shrub which resulted in the formation of tunnels. Thus, both study areas had the same percentage of tunnels, even though Big Creek has a history of overuse.

Shrub densities were calculated using a modified version of the Eberhardt technique (1967). The formulas used in our computations were as follows:

$$D_i = \frac{n_i}{\pi/4 (Y_1^2 + Y_2^2 + Y_3^2 + Y_4^2)}$$

where  $D_i$  = the density at each sampled shrub represented as number of shrubs found around a center shrub divided by the area searched ( $i = 1, k$ ),

$k$  = the number of sampling points in a study area,

$n_i$  = the number of shrubs found at the  $i$ th sampling point,

$Y_1, Y_2, Y_3, Y_4$  = the distance searched until a shrub was found or 100 m was reached in the NW, NE, SE, and SW quadrants,

$$\bar{D} = \frac{\sum_{i=1}^k D_i}{k}, \quad v(\bar{D}) = \frac{\sum_{i=1}^k (D_i - \bar{D})^2}{k - 1}$$

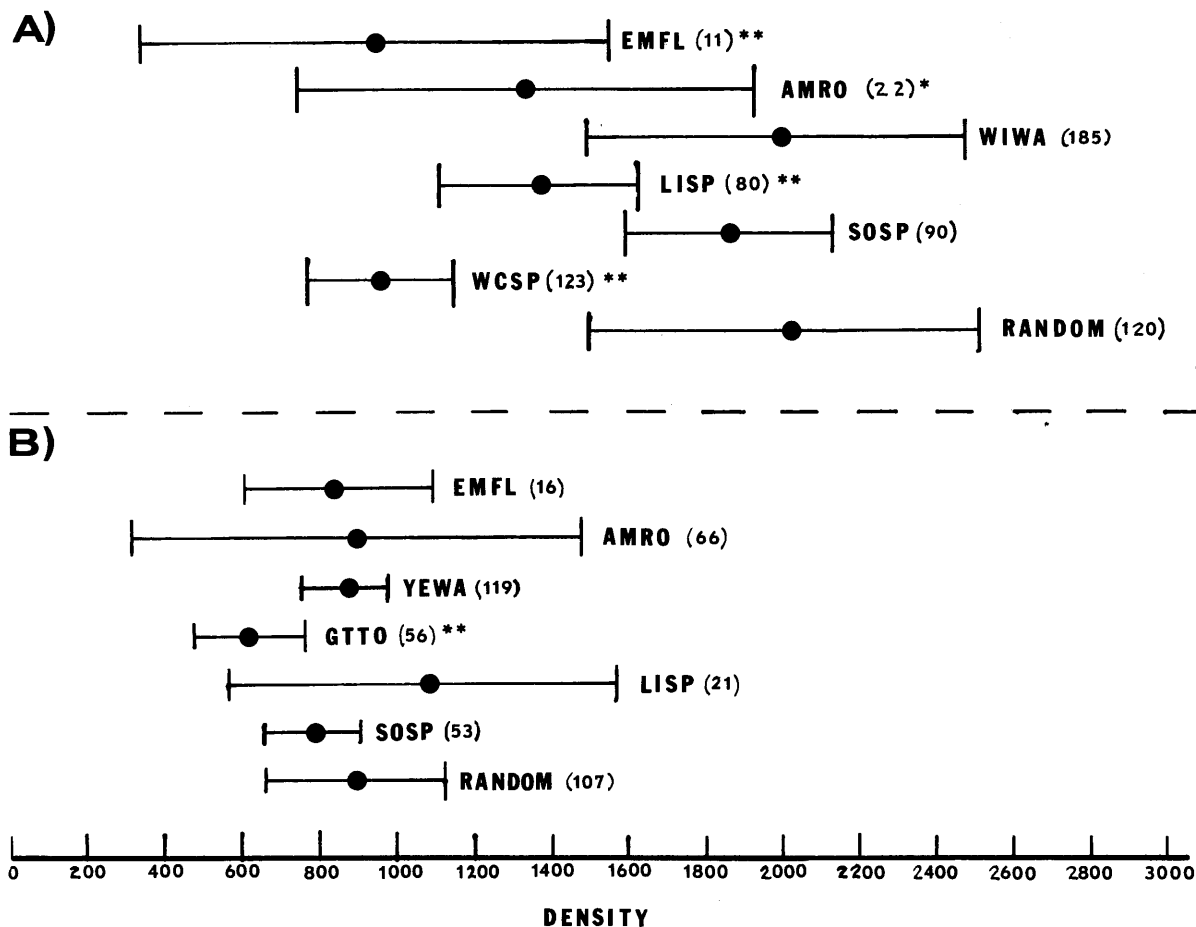

Figure 1.--Mean densities and 95% confidence intervals of willow shrubs for birds and random samples of (A) Pelton Creek and (B) Big Creek. All densities are expressed as shrubs per hectare. Species names are abbreviated as in appendix 1. Sample sizes are given in parentheses. \* = significant difference at  $P < 0.10$ , \*\* = significant difference at  $P < 0.05$ .

The comparison of the shrub densities between the two study areas are given in Table 1. A two sided t-test assuming unequal variances was computed to test for a significant difference between the study area densities (Sokal and Rohlf 1981). Pelton Creek was found to have a statistically higher shrub density than Big Creek ( $P < 0.05$ ).

Table 1.--Shrub densities calculated for randomly located shrubs in each of the two study areas. Densities are expressed as the number of shrubs per hectare.

	n	$\bar{x}$	sd	95% confidence interval
Pelton Creek	120	2007	2792	1503 - 2522
Big Creek	107	897	1221	663 - 1131

To examine how different bird species in each study area responded to shrub-willow densities, shrub densities around bird sightings were compared to random samples using t-tests ( $P = 0.05$ ). The results displayed in Figure 1 indicate that birds of Big Creek, with the exception of Green-Tailed Towhees (for scientific names see appendix 1), show no preference for shrub densities. Pelton Creek

on the other hand had several bird species preferring different densities. In Pelton Creek, densities for Lincoln Sparrows, Empidonax flycatchers, White-Crowned Sparrows and American Robins were significantly different from random samples ( $P < 0.05$ , for American Robin  $P < 0.10$ ).

The increase in bird species preferring certain shrub densities in Pelton Creek can be explained by greater variation in willow densities. This is supported by the larger confidence interval for Pelton Creek in Figure 1 and the larger standard deviation for density in Table 1. Thus, Pelton Creek has a greater variety of willow densities from which birds can, and do choose.

This study was designed to document how cattle can affect shrub-willow riparian vegetation. Cattle impact riparian habitats by trampling vegetation, compacting soils, and changing plant species composition (Platts 1979). In dense stands of shrub-willow riparian habitats the major impact of cattle is to alter the structure and densities of willows within the community. Knopf and Cannon (1982) concluded that cattle in shrub-willow riparian habitats altered the shape, size, volume, and quantities of live and dead stems in the bushes. This influence

on structure and distribution can have both beneficial and deleterious effects on wildlife.

One benefit to wildlife in dense shrub-willow communities is the formation of tunnels throughout the shrub-willow habitat. Both study sites were found to have 41% of the shrubs that were sampled forming tunnels. The formation of tunnels occurs when cattle move through willows busting out lower branches. The concept of tunnels is an extension of an idea proposed by Knopf and Cannon (1982), who described the alteration of shrub structure by cattle as a "notching" effect. When two shrubs are in contact with each other, the two notches form the sides and roof of a tunnel. In most cases tunnel width increased as tunnel height increased. Tunnel floors were covered by a mat of grasses and/or sedges. Tunneling therefore had the effect of increasing the amount of grassland habitat.

Heights of tunnels in the two study areas varied from 0.1 to 1.8 m with the mean height for Pelton Creek being 0.75 m ( $s=0.32$ ) while the mean height for Big Creek was 0.95 m ( $s=0.37$ ). The means and standard deviations ( $s$ ) of tunnel heights tend to correspond closely to heights one would expect for cows, calves, steers, and yearlings. Of course not all tunnels are created by cattle, some are formed by deer and elk while others may be formed by beaver or phenomena we have not yet observed. However, when one considers the large number of cattle that have historically been grazed in the two study areas it seems logical to conclude that cattle have been the major contributor to tunnel formation.

Biologically, tunnels are important to both small mammals and birds because they create structural diversity as well as increase the amount of grassland habitat (grasses and sedges) within the shrub-willow community. Birds are particularly responsive to the structural diversity of vegetation (MacArthur and MacArthur 1961, Roth 1976). Small mammal diversity was found to increase in channelized streams because of the increase in grassland vegetation in these habitats (Geier and Best 1980). The increase in grassland vegetation contributes to habitat diversity which in turn can increase the diversity of the insect community (Price 1975). Insects are important to birds as a valuable food source. Another potential advantage of tunnels for both birds and small mammals is the cover they provide from aerial predators such as Sharp-Shinned Hawks. Birds were frequently observed flying through the tunnels to forage and move through the shrub-willow vegetation. This was particularly true for birds traveling to and from nests.

The benefit gained from grazing dense shrub-willow sites is the formation of tunnels throughout this habitat. This can be achieved when a manager can control the distribution of cattle in his allotment to prevent the detrimental effects of overgrazing. These tunnels benefit birds and mammals by opening up the willow habitat which in turn increases the grassland habitat and structural diversity of vegetation.

Structural diversity in vegetation is also affected by the density of willow shrubs. The mean density of shrubs in Pelton Creek was 2007 shrubs per hectare and in Big Creek 897 shrubs per hectare. Pelton Creek had a statistically higher density of shrubs ( $P<.05$ ) than Big Creek. Big Creek has historically been overused which may contribute to a lower shrub density. Knopf and Cannon (1982) concluded that grazing practices and pressure decreased the density of shrubs in one of the three pastures on their shrub-willow study area. Pelton Creek on the other hand, has had use below the permitted level and good control over the distribution of cattle in the allotment. We believe that this management practice has produced the high density of shrubs in Pelton Creek. We also believe that overgrazing has contributed to reduced shrub density in Big Creek.

Cattle appear to affect bird species by altering shrub-willow structure and density. The logical conclusion from our bird results is that different grazing practices can be used to create a wide spectrum of willow densities that in turn should lead to a diverse avifauna. However, this conclusion is not a sound one. Enough riparian habitat has been overgrazed to create plenty of low density shrub-willow habitats. Another consideration is the fact that all the species in Figure 1 for Big Creek and almost all the species for Pelton Creek are generalists, which means they are not dependent on shrub-willow habitat. Still another consideration is the fact that once structural changes have been made by grazing practices, recovery of high shrub-willow densities will take a very long time (Knopf and Cannon 1982).

The most important consequence of grazing in riparian systems is the impact it may have on the aquatic ecosystem. Meehan and Platts (1978) reported that sedimentation from streambank erosion, removal of vegetative and bank cover, and animal wastes all contribute to the degradation of water quality and fish populations. These perturbations may not be as severe in dense shrub-willow riparian communities. Lorz (1974) found that the presence or absence of grazing in dense willow habitats had little effect on fish populations on the Little Deschutes River. This could be attributed to the anchoring of the stream banks by root systems, and dense structure preventing easy access to streams.

The responsible management of riparian habitats are in the hands of land managers. Sound management of riparian habitats is essential if we are to maintain fisheries and wildlife communities in the western United States. In the management of shrub-willow riparian habitats found in the higher elevations of the Rocky Mountains, cattle can be used as a management tool to benefit small mammal and bird communities by creating tunnels in dense vegetation. However, managers must be able to control the distribution of cattle in allotments to prevent the detrimental effects of grazing.

ACKNOWLEDGEMENTS

We thank USDA Forest Service Rocky Mountain Forest and Range Experiment Station for funding this study. Also George Menkens and Cherry Keller of the Wyoming Cooperative Research Unit for their comments on various forms of this manuscript.

Roath, L. R. and W. C. Krueger. 1982. Cattle grazing influence on a mountain riparian zone. *Journal of Range Management* 35:100-103.  
 Roth, R. R. 1976. Spatial heterogeneity and bird species diversity. *Ecology* 57:773-782.  
 Sokal, R. R. and F. J. Rohlf. 1981. *Biometry*. Second edition. W. H. Freeman and Company, San Francisco, CA. 859 p.

LITERATURE CITED

Eberhardt, L. L. 1967. Some developments in 'distance sampling'. *Biometrics* 23:207-216.  
 Geier, A. R. and L. B. Best. 1980. Habitat selection by small mammals of riparian communities: evaluating effects of habitat alterations. *Journal of Wildlife Management* 44:16-24.  
 Lorz, H. W. 1974. Ecology and management of brown trout in Little Deschutes River. Oregon Department Fish and Wildlife Fisheries Research Report 8. 49 p.  
 Knopf, F. L. and R. W. Cannon. 1982. Structural resilience of a willow riparian community to changes in grazing practices. in Peek, J. M. and P. D. Dalke (Ed.). *Wildlife-livestock relationships symposium: Proceedings 10*. University of Idaho, Forest, Wildlife, and Range Experiment Station, Moscow, Idaho. 614 p.  
 MacArthur, R. H. and J. W. MacArthur. 1961. On bird species diversity. *Ecology* 42:594-598.  
 Meehan, W. R. and W. S. Platts. 1978. Livestock grazing and the aquatic environment. *Journal of Soil and Water Conservation* 33:274-278.  
 Platts, W. S. 1979. Livestock grazing and riparian/stream ecosystems - an overview. p. 31-34. in *Grazing and riparian/stream ecosystems forum proceedings*. Trout Unlimited, Vienna, Va.  
 \_\_\_\_\_ . 1982. Livestock and riparian - fishery interactions: what are the facts? *Transactions of the 43rd North American Wildlife and Natural Resource Conference*. p. 507-515.  
 \_\_\_\_\_ and R. L. Nelson. 1985. Streamside and upland vegetation use by cattle. *Journal of Rangelands* 7:5-7.  
 Price, P. W. 1975. *Insect Ecology*. John Wiley and Sons, NY. 514 p.

APPENDIX 1

<u>Common Name</u>	<u>Scientific Name</u>	<u>Abbreviation</u>
Sharp-Shinned Hawk	<u>Accipiter striatus</u>	SSHA
Empidonax Flycatchers	<u>Empidonax spp.</u>	EMFL
American Robin	<u>Turdus migratorius</u>	AMRO
Yellow Warbler	<u>Dendroica petechia</u>	YEWA
Wilson Warbler	<u>Wilsonia pusilla</u>	WIWA
Green-Tailed Towhee	<u>Pipilo chlorurus</u>	GTTO
Song Sparrow	<u>Melospiza melodia</u>	SOSP
Lincoln Sparrow	<u>Melospiza lincolni</u>	LISP
White-Crowned Sparrow	<u>Zonotrichia leucophrys</u>	WCSP

# Above-Ground Biomass Quantities and Livestock Production at Big Sacaton Riparian Areas in Southeastern Arizona<sup>1</sup>

Jerry R. Cox and Howard L. Morton<sup>2</sup>

---

Abstract.--Two big sacaton (*Sporobolus wrightii*) grassland riparian sites were studied in southeastern Arizona. At site I we measured green biomass, dead standing and standing crops of big sacaton for 3 years. At site II we annually burned or mowed big sacaton pastures in February and annually grazed these pastures plus an untreated control pasture between 1 May and 15 July for three years. Green biomass peaked in August at 1300 and 3000 kg/ha in dry and wet years, respectively. Dead standing biomass accumulated in the fall and disappeared following either fall, winter or summer precipitation. Standing crop (green plus dead standing) was greatest in August and averaged 4400 kg/ha. Both burning and mowing reduced green biomass production. Stocking rates on burned and mowed pastures were only one-third as high as on untreated. Mean daily gains in 1981 and 1982 averaged 0.41 and 0.67 kg/day on untreated and treated pastures, respectively, but total gains per pasture were 512 and 235 kg on the untreated and treated, respectively.

---

## INTRODUCTION

Big sacaton (*Sporobolus wrightii*) grasslands are found where floodwaters accumulate on alluvial flats and flood plains in the southwestern United States and northern Mexico. Because dead standing biomass accumulates in these riparian zones land managers have either annually burned or mowed in late winter (February) and grazed in spring-summer (1 May - 15 July) when upland grasses were dormant. These treatments and spring-summer grazing have been practiced for at least 100 years (Humphrey 1958).

The animal-carrying capacity of semiarid grazing lands is dependent on the amount of plant biomass which is available to be converted into animal biomass. Therefore, a program to evaluate carrying capacity should include studies to: (1) quantify the annual accumulation and decomposition characteristics of live biomass, dead standing biomass and standing crop and (2) grazing studies to relate plant and animal production.

The objectives of this study were to (1) investigate the seasonal dynamics of live biomass, dead standing biomass and standing crop in a big sacaton grassland and (2) evaluate the effect of either annual winter burning or mowing and spring-summer grazing of big sacaton on plant growth, stocking rates and animal gains.

---

<sup>1</sup>Paper presented at the North American Riparian Conference. [University of Arizona, Tucson, April 15-18, 1985].

<sup>2</sup>Jerry R. Cox is Range Scientist, Howard L. Morton is Supervisory Plant Physiologist, U.S. Dep. Agr. - Agr. Res. Serv., 2000 E. Allen Rd., Tucson, AZ 85719. The authors' appreciation is extended to the Donaldson Family at the Empire Ranch for their cooperation, ANAMAX Mining Company for permission to use their land and Reynaldo Madrigal for outstanding technical assistance.

## STUDY SITES

Two sites representative of big sacaton grasslands in the southwestern United States and northern Mexico were selected about 80 km south of Tucson in southeastern Arizona. Site I (Ecological Studies) was in Gardner Canyon and Site II (Grazing Studies) was in the Empire Creek drainage. Both sites are within flood plains at an elevation of 1370 m, and soils are classified as Pima silty clay loam, sandy

loam subsoil, thermic, Typic Haplustolls (Richardson et al. 1979).

Annual precipitation in the area has varied from 175 to 450 mm in the past 50 years (Sellers and Hill 1974). Sixty percent of the annual precipitation usually comes in summer (June - September) and 40% comes in winter (October - April). Day-time temperatures average 30° C in summer and night-time temperatures are often below 0° C in winter. Fall and spring are cool, dry and windy (Cox 1984).

METHODS

Ecological Studies

A 2 ha study area was fenced to exclude livestock. Nine 15 x 15 m plots were established; 3 plots were selected and sampled at 6 week intervals between 6 March 1980 and 6 February 1981, 3 were selected and sampled between 6 March 1981 and 6 February 1982, and the remaining 3 were sampled between 6 March 1982 and 6 February 1983. Plant biomass within a 0.3 x 2.9 m quadrat was separated into live (green) and dead standing (yellow and gray) biomass. Standing crop was determined by adding live and dead standing biomass components. Study design, harvesting and statistical procedures are detailed in Cox 1984.

Grazing Studies

A 16 ha study area was fenced and divided into 4 pastures. Three pastures were 5 ha and one pasture was 1 ha. The three large pastures were randomly assigned one of the following treatments: (1) annual winter (February) burning and spring-summer (1 May - 15 July) grazing (2) annual mowing and spring-summer grazing and (3) spring-summer grazing. The small pasture was retained as an untreated and ungrazed control.

Live and dead standing big sacaton, and other perennial grasses were sampled in each pasture on 27 February. One large pasture was selected as the burned pasture and another as the mowed pasture. The same pastures were burned or mowed in February 1980, 1981 and 1982. All pastures were sampled on 1 May and individually weighed Brahman heifers (1980) and steers (1981 and 1982) released into the three large pastures.

Following late winter and spring burning and mowing big sacaton grasslands in Texas produce abundant green forage in late April and May (Gavin 1982, Haferkamp 1982). We expected a similar response in southeastern Arizona, and stocking rates in 1980 were based on expected growth rates. Our assumption that rapid growth would occur in April and May was incorrect because this period corresponds to a drought season in Arizona, while the same period corresponds to a wet season in Texas. Therefore, the burned and mowed pastures were over-stocked, and heifers were removed and weighed on 1 June 1980.

Stocking rates in 1981 and 1982 were based on

these assumptions: (1) additional plant growth would not occur after 15 May or before the summer rainy season began in mid-July, (2) each grazing animal would eat or trample 10 kg of forage per day, and (3) the desired utilization level when animals were removed on 15 July would not exceed 60% of the standing crop present on 1 May.

The standing crops of big sacaton live biomass, dead standing biomass and other perennial grasses were resampled on 15 May, 1, 15 and 30 June, 15 July and 20 October in 1980, 1981 and 1982. Sampling between 15 May and 15 July was to document forage disappearance. The October date represents peak standing crop after the summer growing season (Cox 1984).

RESULTS

Ecological Studies

Live Biomass

The amounts of live biomass were different at the August sampling dates and similar at the remaining sampling dates over the 3 years (fig. 1). Summer thunderstorms began in early July and most of August was dry in 1980 and 1982. Whereas, thunderstorms began in mid July and occurred regularly through August 1981. As a result, live biomass was 2 to 3 times greater in August 1981 (3250 kg/ha) as compared to August 1980 (1600 kg/ha) and August 1982 (1100 kg/ha).

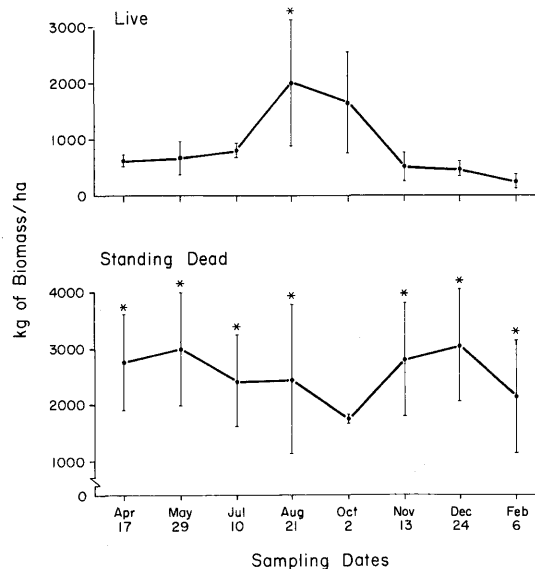

Fig. 1. Three year means and standard errors (kg/ha) for live biomass, dead standing biomass at 8 annual sampling dates for a big sacaton grassland in southeastern Arizona. An asterisk (\*) above the standard error notation indicates a significant difference (P = 0.05) among years at the same sampling date.

## Dead Standing

The amounts of dead standing were similar in October and averaged about 1750 kg/ha over the 3 years (fig. 1). There was significant variation in the amounts of dead standing at the remaining sampling dates over the 3 years.

Dead standing averaged 3200 kg/ha during the dry spring and early summer of 1980. About 50% disappeared between August and October, but a similar amount accumulated from the live component in November. Approximately 45% of the amount that accumulated in fall 1980 disappeared following three snowstorms in January 1981.

Dead standing averaged 1750 kg/ha during the spring and early summer of 1981, and about 40% disappeared following 145 mm precipitation between 10 July and 21 August. Dead standing began to accumulate in fall, and the total amount on 24 December was about 350% greater than on 21 August.

Dead standing averaged 3500 kg/ha during the dry winter and spring of 1981-82. Approximately 25% disappeared in early summer when thunderstorms began, and an additional 25% disappeared in late summer when the thunderstorm activity resumed. Cool-season precipitation in November and December was 110 mm and standing dead averaged 2350 kg/ha. This amount is about 1000 kg/ha less than on the same dates in 1980 and 1981 when precipitation was 20 and 40 mm, respectively. Approximately 36% of the dead standing present in December 1982 had disappeared following three snowstorms in January and one snowstorm in early February 1983.

## Standing Crop

Standing crop, the sum of the live and dead standing components, averaged 2350 kg/ha in February and 4450 kg/ha in August over 3 years. The percent of the live component within the standing crop was less than 50% at all sampling dates except two, 21 August and 2 October 1981.

Peak standing crops varied from 3900 kg/ha in August 1982 to 5150 kg/ha in August 1980. Peak standing crop of big sacaton was 4600 kg/ha in southcentral Texas (Haferkamp 1982) and 4350 kg/ha in west Texas (Gavin 1982).

## Grazing Studies

Burning and mowing immediately removed dead standing biomass while grazing activities resulted in a 45% decline between 1 May and 15 July (fig. 2). Dead standing removal during winter apparently alters plant growth because live biomass in the grazed pasture was about 45 and 35% greater than in the burned and mowed pastures, respectively, on 1 May (fig. 3). These reductions in the available forage resource following either burning or mowing were reflected in pasture stocking rates in 1981 and 1982 (table 1).

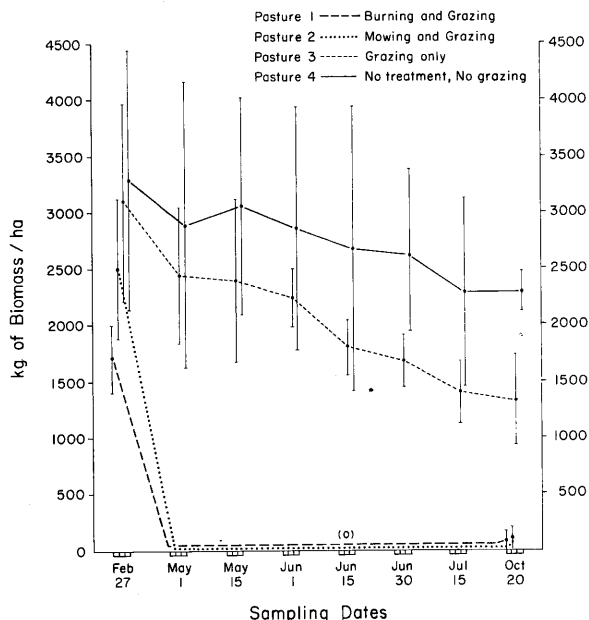

Figure 2. Three year means and standard errors (kg/ha) for big sacaton dead standing biomass at 8 annual sampling dates in four pastures. Burning and mowing treatments were applied in February; grazing was in spring-summer (1 May to 15 July). Peak dead standing after the summer growing season was measured in October.

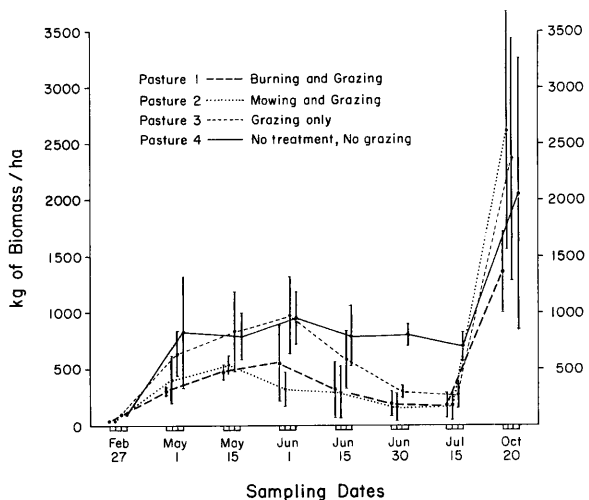

Figure 3. Three year means and standard errors (kg/ha) for big sacaton live (green) biomass at 8 annual sampling dates in four pastures. Burning and mowing treatments were applied in February; grazing was in spring-summer (1 May to 15 July). Peak live biomass after the summer growing season was measured in October.

Table 1. Stocking rates, daily gains and total pasture gains of Brahman heifers (1980) and steers (1981 and 1982) grazing big sacaton in southeastern Arizona. Burning and mowing treatments were applied on 27 February 1980, 1981 and 1982 in the same pastures. Grazing began on 1 May and ended on 1 June in 1980, and on 15 July in 1981 and 1982.

Year	Treatment	Stocking Rate (Head/Pasture)	Daily Gain (kg/Animal)	Total Gain (kg/Pasture)
1981	Burning and Grazing	12	.23	83
	Mowing and Grazing	12	.23	83
	Grazing	12	.45	162
1982	Burning and Grazing	5	.75	283
	Mowing and Grazing	5	.67	250
	Grazing	15	.45	502
1983	Burning and Grazing	4	.74	222
	Mowing and Grazing	5	.50	187
	Grazing	18	.39	522

Heifers and steers preferred other perennial grasses to big sacaton in the three large pastures (figs. 3 and 4), and completely removed the standing crop of other perennial grasses before grazing big sacaton. The standing crop of other perennial grasses was usually removed by 1 June. Cattle began to graze big sacaton but were constantly searching for other perennial grasses between 25 May and 5 June. Between 15 June and 15 July animals grazed entirely on big sacaton.

Average daily gains were highest in the burned pasture, intermediate in the mowed pasture and lowest in the grazed pasture in 1981 and 1982 (table 1). However, stocking rates in the grazed pasture were 3 times greater than in the burned and mowed pastures in 1981 and 1982, and total gains were approximately 2 times greater in the grazed pasture in all 3 years.

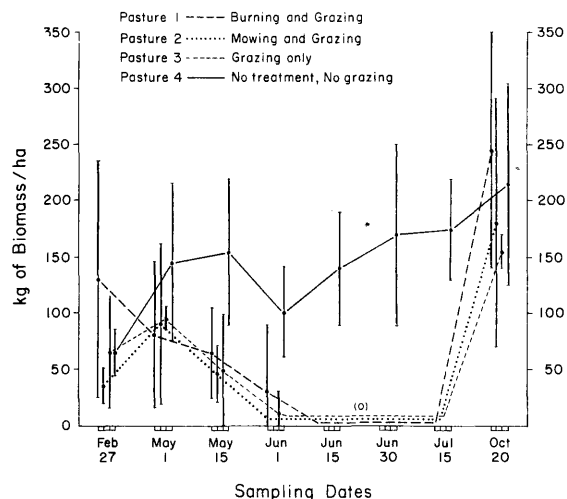

Figure 4. Three year means and standard errors (kg/ha) for other perennial grass biomass at 8 sampling dates in four pastures. Burning and mowing treatments were applied in February; grazing was in spring-summer (1 May to 15 July). Peak other perennial grass biomass after the summer growing season was measured in October.

#### DISCUSSION AND ECOLOGICAL IMPLICATIONS

Dead standing big sacaton biomass will rapidly disappear following precipitation in either fall, winter or summer. These data do not support the commonly accepted belief that dead standing biomass disappears slowly under natural conditions (Griffiths 1901, Humphrey 1960). However, the logic which contributed to this belief is easily understood. Dead standing biomass is the predominant vegetation component within big sacaton grasslands for about 49 weeks of each year, and even though dead standing does disappear after precipitation, it does not accumulate on the soil surface between plants. Therefore, open areas between plants are litter-free for the majority of each year and this would suggest that most dead standing biomass falls into the plant interior and is trapped within the remaining dead standing.

As dead standing disappears following either fall or winter moisture, litter accumulates within the remaining dead standing. This litter source may serve as an important N reserve which becomes quickly available for plant growth in summer through the processes of decay, nitrogen mineralization and nitrification. The entrapment of N within the remaining dead standing probably reduces N losses associated with flooding.



Prior to channelization in big sacaton grasslands these riparian areas acted as a continuous barrier that slowed floodwaters, trapped sediments and enhanced the storage of soil moisture in shallow water tables (Griffiths 1901, Hubbell and Gardner 1950). Under these conditions the solum remained wet for more than 90 continuous days during the growing season (Soil Taxonomy 1979), soils were classified as Haplustolls (Richardson et al. 1979) and live biomass in the spring-summer grazing period on areas which had been burned or mowed in late winter was probably greater than on untreated areas. After channelization, or conditions which currently exist, upslope as well as on site runoff quickly exits alluvial areas through the channel system (Cooke and Reeves 1976), the solum was dry during most of the growing season; soils were reclassified as Torrifluvents (Richardson et al. 1979) and live biomass was greater in the spring-summer grazing period on untreated areas as compared to areas which had been either burned or mowed in late winter.

The increase in daily animal gains would suggest that big sacaton grasslands should be either burned or mowed in late winter and grazed in spring-summer. The increase in carrying capacity on the untreated pasture would suggest that the manager would most likely elect to decrease the carrying capacity and increase daily gains. Therefore, the manager would burn because mowing is more costly (Wright 1969) and then graze. The alternative option of neither burning or mowing but increasing the carrying capacity would be considered unrealistic because it is not logical to assume that increased gain per area will compensate for reductions in daily gains (Launchbaugh and Owensby 1978).

In the past big sacaton grasslands in lowland and flood plains acted as barriers which slowed and spread flood waters. Under such conditions it would seem reasonable to assume that the live biomass produced after burning or mowing would have been greater than on untreated areas because of the extended growing season. These conditions no longer exist and the presented data, collected over 3 years, would suggest that: (1) burning and mowing do not stimulate live biomass production and (2) annual burning and mowing may decrease live biomass production under some conditions. Therefore, the manager who is concerned with the long-term management of natural resources, rather than short-term livestock gains, would likely discontinue the use of late winter burning or mowing and increase carrying capacity during the spring-summer grazing periods.

#### LITERATURE CITED

- Cooke, R. U., and R. W. Reeves. 1976. Arroyos and environmental change in the American southwest. Clarendon Press, Oxford.
- Cox, J. R. 1984. Shoot production and biomass transfer of big sacaton (*Sporobolus wrightii*). J. Range Manage. 37:377-380.
- Gavin, T. M. 1982. The effects of prescribed fire on the production, utilization and nutritional value of sacaton in Brewster County, Texas. M.S. Thesis, Sul Ross State Univ., Alpine.
- Griffiths, D. 1901. Range improvements in Arizona. USDA, Bureau of Plant Industry. Bull. 4.
- Haferkamp, M. R. 1982. Defoliation impacts on the quality and quantity of forage harvested from big sacaton (*Sporobolus wrightii* Monro). J. Range Manage. 35:26-31.
- Hubbell, D. S., and J. L. Gardner. 1950. Effects of diverting sediment-laden runoff to range and croplands. USDA Tech. Bull. No. 1012.
- Humphrey, R. R. 1958. The desert grassland. Bot. Rev. 24:193-253.
- Humphrey, R. R. 1960. Arizona range grasses. Arizona Agr. Exp. Bull. 298.
- Launchbaugh, J. L., and C. E. Owensby. 1978. Kansas rangelands; Their management based on a half century of research. Kansas Agr. Exp. Sta. Bull. 622.
- Richardson, M. L., G. D. Clemmons, J. C. Walker. 1979. Soil survey of Santa Cruz and parts of Cochise and Pima Counties, Arizona. National Cooperative Soil Survey, USDA, Soil Cons. Serv., Forest Serv. and Arizona Agr. Exp. Sta. Washington, DC.
- Sellers, W. D., and R. H. Hill. 1974. Arizona climate (1931-1972). Univ. of Arizona Press, Tucson.
- Soil Taxonomy. 1979. A basic system of soil classification for making and interpreting soil surveys. USDA, Soil Conservation Serv., Agr. Handb. No. 436.
- Wright, H. A. 1969. Effect of spring burning on tabosgrass. J. Range Manage. 22:425-427.

# Trout Habitat, Abundance, and Fishing Opportunities in Fenced vs Unfenced Riparian Habitat along Sheep Creek, Colorado<sup>1</sup>

Robert J. Stuber<sup>2</sup>

---

Abstract.--Fencing was used to protect 40 hectares of riparian stream habitat along 2.5 km of Sheep Creek, Colorado, from adverse impacts due to heavy streamside recreation use and cattle grazing. Fish habitat within the fenced area was narrower, deeper, had less streambank alteration, and better streamside vegetation than comparable unfenced sections. Estimated trout standing crop was twice as great, and proportional stock density (PSD) was higher than in unfenced sections. There was a higher proportion of nongame fish present in unfenced sections. Projected fishing opportunities within the fenced sections were double those estimated for a comparable length of unfenced habitat along the same stream.

---

## INTRODUCTION

The integrity of riparian/stream ecosystems is extremely important from the perspective of fisheries, since the quality of existing fish habitat is often directly related to the overall condition of the riparian habitat. This is especially true for many medium and small size coldwater streams, as the smaller the stream, the more important the riparian zone and the influence it has (Raleigh 1979). Well developed riparian vegetation provides a number of benefits for salmonids, including cover (Raleigh 1982), streambank stabilization (McCluskey et al. 1983), shading for stream temperature regulation (Reiser and Bjornn 1979; Raleigh 1982), and a source of allochthonous food input (Meehan et al. 1977; Raleigh 1982). Maintaining this integrity is very important, especially in light of increasing angling use on many of these streams.

Multiple land use practices often result in fish habitat degradation within the riparian/stream ecosystem. Man has dramatically reduced the quantity and quality of natural riparian ecosystems by intensively developing them for other uses. This development has resulted in losses of natural vegetation to the detriment of fish and wildlife and associated recreation (Swift 1984). Fencing riparian habitat is one technique which has been employed to protect or improve fish habitat where conflicting land uses

have resulted in degradation. Fencing was used to protect riparian stream habitat along Sheep Creek, Colorado, from adverse impacts due to heavy streamside recreational use (e.g., recreational vehicles, camping, etc.) and cattle grazing. Trout habitat characteristics and abundance are compared in an ongoing evaluation between fenced and unfenced sections of stream.

The purpose of this paper is to discuss differences in these parameters, along with projected potential fishing opportunities in the fenced portion of Sheep Creek versus a comparable length of unfenced habitat along the same stream.

## METHODS

### Study Area

Sheep Creek is a small (4-5 m width) stream on the Arapaho and Roosevelt National Forests within the South Platte River basin in northeastern Colorado. Elevation of the section under consideration is approximately 2,500 m. Low flow is about 0.2 - 0.3 m<sup>3</sup>/sec. It is a C-1 stream type according to a Forest Service stream classification procedure (Rosgen 1985). Gradient is 1.0 - 1.5% and sinuosity is 1.5 - 2.0. Dominant channel material is cobble with a mixture of small boulders and coarse gravel. The channel is moderately confined. Soils within the valley bottom are predominantly coarse textured, with stable high alluvial terraces.

A total of 2.5 km of stream on National Forest land was originally fenced in 1956 to protect 40 hectares of riparian/stream habitat from cattle grazing impacts. The fences were maintained periodically; however, in recent years

---

<sup>1</sup>Paper presented at the symposium, Riparian Ecosystems and Their Management: Reconciling Conflicting Uses, April 16-18, Tucson, Arizona.

<sup>2</sup>Fisheries Biologist, USDA Forest Service, Arapaho and Roosevelt National Forests, Fort Collins, Colorado.

the fences had fallen into a state of disrepair and were rebuilt in 1982-83. Both the original construction and repair were a cooperative effort by the Colorado Division of Wildlife and Forest Service. The fenced area is divided into two enclosures (1.9 and 0.6 km of stream, respectively), with 1.3 km between, and 4.0 km of unfenced habitat above them (Fig. 1). Present impacts on the unfenced riparian habitat are heavy streamside recreational use and cattle grazing. It should be noted the land adjacent to Sheep Creek outside the fenced areas is in private ownership.

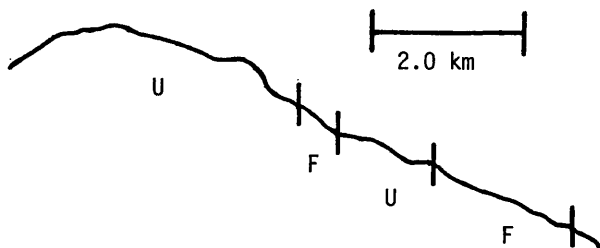

Figure 1.--Location of fenced (F) and unfenced (U) sections of Sheep Creek, Colorado

#### Habitat Sampling

Habitat measurements were taken at two 125 m representative stations in 1984, one inside and one outside the fenced area. The unfenced sampling station was between the two enclosures. Five stream/riparian habitat parameters were measured: stream width, depth, streambank alteration (% eroding banks), streambank vegetative stability (% vegetation), and streamside cover (dominant vegetation type). The width/depth ratio was also calculated. It was felt that these six characteristics would yield a comparative assessment of the overall fish habitat condition between the two areas. Vegetative stability and streamside cover were rated from 1 (worst) to 4 (best). Measurements and applicable ratings were made according to procedures outlined by Platts et al. (1983).

#### Fish Population Sampling

Three stations were sampled in late October, 1983 (one inside vs. two outside); the onset of winter weather conditions precluded additional sampling. Five stations were sampled in late September, 1984 (three inside vs. two outside). All stations were 125 m in length, and sampling was done with a generator powered electrofishing unit. The habitat stations sampled in 1984 were two of the fish population stations sampled in both 1983 and 1984.

Three fish population characteristics were compared between fenced and unfenced areas: (1) relative species occurrence (both trout and

nongame fish); (2) trout standing crop (kg/ha); and, (3) trout species proportional stock density (PSD), an index of potential fishing quality based on lengths of fish (Anderson 1980). Only fish  $\geq 150$  mm in length were utilized in these estimates. Data from the individual stations were pooled (fenced vs. unfenced) for the comparative estimates. Population estimates for trout were made using the Seber and Le Cren (1967) two capture method. Lengths and weights of all captured fish were taken and trout standing crop estimates were made. Stock and quality lengths for the trout species PSD calculations were taken from Anderson (1980).

#### Fishing Opportunities

Projected potential fishing opportunities within fenced areas were compared with those from unfenced sections of the stream. Projections were based upon a fact (known angling use per km of stream in Colorado) combined with an assumption (stream fishery value can be equated to opportunities for angling use). The rationale behind this approach is presented below.

The Colorado Division of Wildlife (1983) reported that the 13,600 km of coldwater stream supported 3.8 million fishing-days in 1980 (280 fishing-days per km). According to the USDA Forest Service (1980), three fishing-days equal one recreational visitor day (RVD). Therefore, 1.0 km of stream supported 93 RVD's for coldwater fishing in 1980. The Division of Wildlife also assigns one of six fishery values to a stream (None, Poor, Below Average, Average, Above Average, Excellent). It was assumed that a stream with an "Average" fishery value would support 93 RVD's (per km per year) of coldwater fishing, and that the remaining fishery values would support a proportionate amount of projected use (Table 1).

Projected fishing opportunities within fenced vs. unfenced areas were obtained by arbitrarily assigning a fishery value to each respective area based on trout standing crop and PSD estimates. Total opportunities within the fenced section of stream and a comparable length of unfenced stream were standardized by multiplying the respective projected opportunities per km of stream by 2.5 km (length of fenced section of stream).

Table 1.--Projected RVD's (per km of stream per year) associated with fishery value of stream in Colorado.

Fishery Value	RVD's
None	0
Poor	31
Below Average	62
Average	93
Above Average	124
Excellent	155

Table 2.--Comparative fish habitat characteristics between fenced and unfenced sections of Sheep Creek, Colorado, 1984.

	<u>Fenced</u>	<u>Unfenced</u>
Average width (m)	3.7	5.5
Average depth (m)	0.2	0.1
Width:Depth	18.5	55.0
Streambank alteration (% eroding banks)	Moderate (26-50)	Major (51-75)
Streambank stability (% vegetation)	Good (50-79)	Fair (25-49)
Streamside cover (rating) (dominant vegetation type)	4 (Excellent) (Shrubs)	2 (Fair) (Grass/Forbs)

## RESULTS

### Fish Habitat

The stream was generally wider and shallower in unfenced areas as there was a significant difference in the average width ( $P = 0.0002$ ) and depth ( $P = 0.0006$ ) between the two areas. This resulted in a much lower width/depth ratio within the fenced area (Table 2). Also, there was more streambank alteration, less streambank vegetative stability, and lower quality streamside cover in the unfenced area.

### Fish Population

On a relative basis there were significantly more game fish (trout) present in the fenced sections, and the number of nongame fish (longnose suckers; *Catostomys catostomus*) was higher in unfenced areas ( $X^2$  analysis;  $P = 0.0001$ ). Brown trout (*Salmo trutta*) were the predominant species captured in both fenced and unfenced areas. Brook trout (*Salvelinus fontinalis*) and rainbow trout (*Salmo gairdneri*) were also captured within both areas (Table 3). All captured fish were from wild populations, as no stocking takes place.

There was a significant difference ( $P = 0.04$ ) in estimated trout standing crop in 1983 between fenced vs. unfenced areas as estimated standing crop was 96% higher (91.0 kg/ha greater) within fenced areas (Fig. 2). Estimated trout standing crop was 127% higher (74 kg/ha) within fenced areas in 1984, although this was not significantly different ( $P = 0.08$ ) from unfenced areas.

Proportional stock density (PSD) values for brown trout within the fenced areas were 8.3 and 5.1 in 1983 and 1984, respectively, compared with a value of zero within the unfenced areas in both years. In other words, 8.3 and 5.1%

Table 3.--Relative abundance (%) of trout and nongame species captured in fenced vs. unfenced sections of Sheep Creek, Colorado, 1983-84 (average value from both years).

	<u>Fenced</u>	<u>Unfenced</u>
Trout	96.5	85.0
Brown	91.5	72.5
Brook	4.0	9.5
Rainbow	1.0	3.0
Nongame (Longnose Sucker)	3.5	15.0

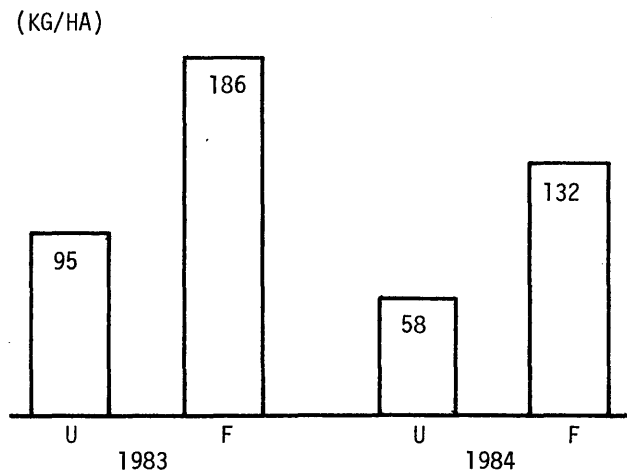

Figure 2.--Comparative average trout standing crop estimates between unfenced (U) and fenced (F) sections of Sheep Creek, Colorado.

of the stock size ( $\geq 200$  mm) brown trout were of quality size (325 mm or larger) within the fenced areas in 1983 and 1984, respectively, and there were no quality size brown trout in the unfenced areas in either year. The largest fish captured in both 1983 and 1984 were brown trout from the fenced areas (500 and 375 mm, respectively). There were no quality size rainbow or brook trout captured within either fenced or unfenced areas in both years.

#### Fishing Opportunities

Fishing opportunities within the fenced area and a comparable length of unfenced stream were projected to be 310 vs. 155 RVD's per year, respectively (e.g., 310 RVD's = 124 RVD's/km/year x 2.5 km, etc.). These projections were based on the assumptions that the fishery value within the fenced area was "Above Average" (124 RVD's/km/year; Table 1) whereas it was "Below Average" (62 RVD's/km/year) in the unfenced area. These assumptions were in turn based on the facts that estimated trout standing crop was twice as great in fenced areas and that there were quality fishing opportunities for brown trout (based on PSD values) within the fenced area, whereas none were present in the unfenced area.

#### DISCUSSION

Protection of the riparian stream ecosystem by fencing resulted in superior fish habitat conditions. Fenced areas had a narrower stream width, greater depth, and a lower width/depth ratio. Depth is important in providing a combination of pools, cover and instream movement areas for trout (Raleigh 1982). Lower width/depth ratios are associated with better fish habitat (Behnke and Zarn 1976; Platts 1981). The more stable streambanks (lower % eroding banks) and good streambank vegetative stability within fenced areas provide protection from erosion and subsequent siltation within the stream. The predominance of well-developed shrubs (willows) within the fenced area contribute more streamside cover than the grass/forbs which predominate in unfenced areas. Platts (1974) found that streams bordered by shrubs had higher fish standing crops than similar sized streams with other vegetation type borders. It appears that heavy streamside recreation use and cattle grazing have resulted in adverse impacts to the stream/riparian habitat in the unfenced sections of stream, which was evidenced by the results of the comparative habitat sampling (i.e., wider, shallower stream, more streambank alteration, etc.). It has been demonstrated in numerous other studies that protected sections of stream have superior fish habitat conditions. See Platts (1982) and Platts and Wagstaff (1984) for a synopsis of the results of these studies.

Increased estimated trout standing crop within the fenced area was the result of superior habitat conditions. Binns and Eiserman

(1979) felt that the best fluvial trout habitat is associated with a high standing crop. Trout standing crop estimates were 96.5% higher (1983-84 average) within the fenced areas of Sheep Creek. Greater trout abundance within protected riparian stream habitat has been reported in other similar studies. Gunderson (1968) reported that brown trout standing crop was 31% greater in an ungrazed vs. an adjacent grazed section of Rock Creek, Montana. In a subsequent study, Marcuson (1977) reported that standing crop inside the ungrazed area had increased to 3.4 times that found in the grazed section of this same stream. Van Velson (1979) found that the fish population of Otter Creek, Nebraska, changed from 88% nongame fish to 97% trout after 4.8 km were fenced to exclude livestock.

Platts (1982) felt that these studies were somewhat biased, as there was no pre-treatment data, and it could not conclusively be proven that differences in reported trout abundance were not just a natural occurrence. The present study at Sheep Creek lacks pre-fencing fish population and habitat data; however, the fenced and unfenced sections have similar channel type, substrate, gradient, flow regime, and geomorphology. These similarities reduce the possibility that the differences were just a natural occurrence and it can safely be assumed that protection has resulted in superior habitat conditions and higher trout standing crop.

In addition to providing better habitat conditions, it should be noted that the well developed willow stands along the fenced sections of Sheep Creek probably offer some protection for trout from anglers. Fishability is more difficult than in adjacent unfenced sections and this fact may also contribute to the higher estimated standing crop.

In conclusion, fencing for the protection of the riparian/stream ecosystem at Sheep Creek has resulted in superior fish habitat conditions, 96.5% higher estimated trout standing crop, higher PSD values, and twice the projected potential fishing opportunities than in adjacent unfenced areas.

#### ACKNOWLEDGMENTS

The author gratefully acknowledges John Bustos of the Redfeather Ranger District for his coordination of fence reconstruction and maintenance. Thanks are also given to Steve Puttmann and Doug Krieger of the Colorado Division of Wildlife for coordinating the fish population sampling. The author is grateful to the following individuals who have assisted with various phases of this study: John Englebert, Nancy Ryke, Del Lobb, Nancy Dobbs, and Pat Beauchamp. Rod Van Velson of the Division of Wildlife provided a constructive review of the manuscript. Finally, sincere gratitude is expressed to Linda McLees and Gayle Porter for typing, and Henry Salas for graphic illustrations.

## LITERATURE CITED

- Anderson, R. O. 1980. Proportional stock density (PSD) and relative weight ( $W_r$ ): Interpretive indices for fish populations and communities. pp. 27-33 in *Practical Fisheries Management: more with less in the 1980's*, Workshop Proceedings. Gloss, S. and B. Shupp, eds. New York Chapter, American Fisheries Society.
- Behnke, R. J. and M. Zarn. 1976. Biology and management of threatened and endangered western trout. USDA Forest Service, Gen. Tech. Rep. RM-28.
- Binns, N. A. and F. M. Eiserman. 1979. Quantification of fluvial trout habitat in Wyoming. *Trans. Am. Fish. Soc.* 108:215-218.
- Colorado Division of Wildlife. 1983. Today's strategy...tomorrow's wildlife. A Comprehensive Management Plan for Colorado's Wildlife. Third ed., Colo. Div. Wildl., DOW-M-D-I-83, Denver. 96 p.
- Gunderson, D. R. 1968. Floodplain use as related to stream morphology and fish populations. *J. Wildl. Manage.* 32(3): 507-514.
- Marcuson, P. E. 1977. The effect of cattle grazing on brown trout in Rock Creek, Montana. Spec. Proj. Rep. F-20-R-21-11-a. Montana Dept. Fish and Game, Helena. 26 p.
- McCluskey, D. C., J. Brown, D. Bornholdt, D. A. Duff, and A. H. Winhard. 1983. Willow Planting for Riparian Habitat Improvement. Tech. Note 363, USDI Bureau Land Mgmt., Denver, Colo. 21 p.
- Meehan, W. R., F. J. Swanson, and J. R. Sedell. 1977. Influences of riparian vegetation on aquatic ecosystems with particular reference to salmonid fishes and their food supply. pp. 137-145 in *Proc. Symposium on Importance, Preservation, and Management of Riparian Habitat*. USDA Forest Service Gen. Tech. Rep. RM-43.
- Platts, W. S. 1974. Geomorphic and aquatic conditions influencing salmonids and stream classification - with application to ecosystem management. USDA SEAM Program Billings, Montana 199 p.
- Platts, W. S. 1981. Effects of sheep grazing on riparian - stream environment. USDA Forest Service Res. Note INT-307.
- Platts, W. S. 1982. Livestock and riparian-fishery interactions: What are the facts? pp. 507-515 in *Trans. 47th N. American Wildlife and Natural Resource Conference*, Wildlife Management Institute, Washington, D.C.
- Platts, W. S., W. F. Megahan, and G. W. Minshall. 1983. Methods for evaluating stream, riparian, and biotic conditions. USDA Forest Service Gen. Tech. Rep. INT-138.
- Platts, W. S. and F. J. Wagstaff. 1984. Fencing to control livestock grazing on riparian habitats along streams: is it a viable alternative? *N. Am. J. Fish. Manage.* 4:266-272.
- Raleigh, R. F. 1979. Closing remarks. pp. 89-90 in *Proc. of Forum - grazing and riparian/stream ecosystems*, O. B. Cope, ed., Trout Unlimited, Vienna, Virginia.
- Raleigh, R. F. 1982. Habitat suitability index models: Brook trout. USDI Fish and Wildlife Service. FWS/OBS-82/10.24. 42 p.
- Reiser, D. W. and T. C. Bjornn. 1979. Habitat requirements of anadromous salmonids in Influence of forest and rangeland management on anadromous fish habitat in western North America. USDA Forest Service Gen. Tech. Rep. PNW-96.
- Rosgen, D. 1985. A stream classification system. in *Proc. of Riparian ecosystems and their management*, Tucson, Arizona, April 16-18, 1985. USDA Forest Service, Rocky Mountain Forest and Range Experiment Station General Technical Report series (in preparation).
- Seber, G. A. and E. D. LeCren. 1967. Estimating population parameters from catches large relative to the population. *J. Animal Ecology* 36(3):631-643.
- Swift, B. L. 1984. Status of riparian ecosystems in the United States. *Water Resources Bulletin* 20(2):223-228.
- USDA Forest Service. 1980. Resource planning act assessment, 1980. USDA Forest Service, Washington, D.C.
- Van Velson, R. 1979. Effects of livestock grazing upon rainbow trout in Otter Creek. pp. 53-55 in *Proc. of Forum - grazing and riparian/stream ecosystems*, O. B. Cope, ed. Trout Unlimited, Vienna, Virginia.

# The Value of Riparian Zones for Protecting Aquatic Systems: General Concerns and Recent Studies in Maine<sup>1</sup>

John R. Moring<sup>2</sup>  
Greg C. Garman<sup>3</sup>  
Dennis M. Mullen<sup>4</sup>

---

Abstract.--Riparian zones serve important functions for fisheries and aquatic systems: shading, bank stability, prevention of excess sedimentation, overhanging cover for fishes, and energy input from invertebrates and allochthonous material. Impacts from loss of riparian areas are discussed in relation to aquatic ecosystems, and the results of two recent studies in Maine are reviewed.

---

## INTRODUCTION

Any land disturbance in a watershed, whether due to logging activities, road or other construction, agriculture, or other activities, can directly or indirectly affect stream ecosystems. In forested watersheds, aquatic life is most affected by logging and related activities in the nearby areas. The more extensive such cutting, the greater the potential for environmental and biological changes in streams.

Use of a buffer strip of intact riparian vegetation can be an effective deterrent to many of the changes in streams brought about by land disturbances. Riparian vegetation acts to shade streams, provide bank stability, provide overhead cover and food for fishes (via insect drift), and provide allochthonous input to fuel the aquatic ecosystem. The forest canopy/riparian zone thus effectively becomes part of the aquatic ecosystem, as changes in the riparian component can directly alter the aquatic component.

In Maine, where 89% of the land is forested, land use regulations in unincorporated territories allow only limited cutting within riparian zones. But, because of extensive damage from spruce budworm in fir and spruce stands (approximately 10 million acres are moderately to severely infested in Maine alone), there have been increased numbers of applications submitted for exclusion permits to cut close to streams. Thus, knowledge of the potential impacts of removing riparian vegetation

to fish and other aquatic life is becoming increasingly important to resource managers. Two recent studies in Maine addressed these concerns. One, on School Brook, examined aquatic primary production before and after cutting. The other, on the East Branch Piscataquis River, dealt with changes in physicochemical and biological conditions following salvage cutting.

The objectives of this paper are to (1) review the beneficial characteristics of riparian zones with respect to aquatic life, and indicate how the removal or alteration of such vegetation can affect stream ecosystems, and (2) briefly summarize the results of the two recent studies in Maine where riparian vegetation was removed along streams during logging.

## BENEFITS OF RIPARIAN ZONES

### Physicochemical Conditions

Studies concerning environmental changes following removal of riparian vegetation are relatively extensive from western North America and the Appalachian Mountains. But, with the exception of studies by Martin et al. (1981), Englert et al. (1982), and a few others, such riparian-related studies have been rare in New England. With soil excavation, sediment levels can increase, particularly in steep terrains and during road construction (Brown and Krygier 1971, Krammes and Burns 1973, Platts 1974, Moring 1975, Beschta 1979). The Maine Land Use Regulation Commission (1979) concluded that equipment used in riparian areas was largely responsible for the increased levels of sediment entering areas of low gradient in Maine.

These increased levels of sediment fines have been directly linked to decreased survival of developing fish eggs and emerging alevins (Cooper 1965, Koski 1966, Phillips et al. 1975). Though riparian zones act to filter excess sediment from entering streams, significant increases can still

---

<sup>1</sup>Paper presented at the North American Riparian Conference (Tucson, Arizona, April 16-18, 1985).

<sup>2</sup>John R. Moring is Associate Professor of Zoology, University of Maine, Orono, Maine.

<sup>3</sup>Greg C. Garman is a Post-Doctoral Fellow, Northeast Atlantic Fisheries Center, Fisheries and Oceans, St. John's, Newfoundland.

<sup>4</sup>Dennis M. Mullen is a Zoology Research Technician, University of Maine, Orono, Maine.

occur in areas of steep terrain, heavy rainfall or snowmelt, or in watersheds with large disturbed areas. When riparian vegetation is removed, stream-bank stability is low, and sedimentation may enter streams over an extended period of time. With the removal of vegetation, stream flow often increases, particularly if riparian areas are cut (Rowe 1963, Meehan et al. 1969, Rothacher 1970, Swank and Helvey 1970, Moring 1975, Graynoth 1979, Verry et al. 1983).

Levels of intragravel and surface dissolved oxygen often decline following logging, particularly if riparian vegetation is diminished (Iwanaga and Hall 1973, Moring and Lantz 1974, Moring 1975, Ringler and Hall 1975). Although levels eventually return to pre-cutting values (dependent on water temperature, stream flow, and other factors), the period of depressed values of dissolved oxygen and permeability can be sufficiently low to result in mortalities of developing eggs and alevins (Moring 1981, 1982) as well as adult and juvenile fishes in streams (Hall and Lantz 1969, Moring and Lantz 1975, Moring 1981).

If overstory vegetation near streams is opened, water temperatures can increase dramatically (Chapman 1962; Brown and Krygier 1967, 1970; Gray and Edington 1969; Meehan 1970; Narver 1972; Moring 1975; Welch et al. 1977; Lynch et al. 1984). The magnitude of this increase depends on the presence or absence of a riparian buffer strip, the size of the cut area, the adoption of slash burning or debris clearance, and the soil type. These temperature changes can be long term (Moring 1975, Feller 1981). Even a partial buffer of riparian vegetation may not be enough: a study by Hewlett and Fortson (1982) indicated a significant increase in water temperature when only a partial riparian strip remained after logging.

#### Biological Conditions

Aquatic communities in woodland streams depend on the surrounding forest for energy. This allochthonous input drives the aquatic ecosystem (Minshall 1967, Benke and Wallace 1980). When the riparian canopy is removed, this basic energy source is altered. Allochthonous input and insect input decreases. When environmental conditions change, invertebrate numbers and diversity often change (Gurtz et al. 1980, Murphy and Hall 1980, Newbold et al. 1980, Martin et al. 1981, Murphy et al. 1981). A direct relationship has often been noted between land use practices, invertebrate density and diversity, and the presence or absence of intact riparian zones.

Fishes are the highest order consumers in woodland streams, and are directly dependent on invertebrates for food and indirectly dependent on physicochemical constraints for acceptable habitat and conditions for metabolism. When riparian vegetation is removed, environmental conditions in streams (particularly temperature, dissolved oxygen, sedimentation, and stream flow) often change, significantly affecting fish populations (Hall and Lantz 1969, Meehan et al. 1969, Burns 1972, Moring and Lantz 1975, Reed and Elliott 1978, Moring 1981).

The presence of an intact riparian zone is essential for mitigating wide variations in environmental conditions. The approximate width of such "buffer" riparian strips has been the subject of some studies (Brazier and Brown 1973, Erman et al. 1977, Newbold et al. 1980, Erman and Mahoney 1983, etc.), though most federal and state agencies, where riparian cutting policies are in force, use a 23 m (75 ft) intact riparian zone, on each side of a stream, within which all cutting or other activity is prohibited. Several states are now encouraging landowners to retain riparian zones, even when not legally required to do so, by utilizing tax incentives.

#### THE SCHOOL BROOK STUDY

School Brook, a small tributary to the Aroostook River, is located near Oxbow, Maine. The spruce-fir canopy provided shading to this important nursery stream for brook trout (*Salvelinus fontinalis*). A salvage clearcut, extending along 1,500 m (4,920 ft) of one bank of the stream, was undertaken in winter 1983-1984. The objective of the study was to measure instream primary productivity to determine if autochthonous energy input increased after cutting in the watershed.

Primary production was measured in June and August 1983, and June, August, and October 1984 at each of four sections in the control and experimental sections. Details of techniques have been reported by Mullen (1985), but production rates were estimated using closed recirculating chambers similar to those described by Bott et al. (1978).

No significant differences were noted in production by periphyton communities before and after cutting and between control and experimental sections. Rather than being a rejection of the hypothesis of increased primary production following logging, the results were inconclusive because the removal of riparian vegetation along only one side of the stream resulted in just a 5% reduction in effective canopy. And, the orientation of the cut was such that the angle of the sun did not allow sunlight to directly penetrate forest cover.

Population estimates of brook trout indicated no significant differences between cut and uncut sections in the stream. Populations in both control and experimental sections increased after logging. However, any changes in water temperature were mitigated by cool spring water entering the brook at several locations. Together with the limited removal of the canopy, brook trout populations were essentially not affected by changes in environmental conditions. Thus, under the conditions of that stream and that individual, limited cut, the aquatic system was little changed.

#### EAST BRANCH PISCATAQUIS RIVER STUDY

The few studies conducted in New England dealing with removal of riparian vegetation have dealt with nutrient loss (Bormann et al. 1970, Likens et al. 1970, Hall et al. 1980, etc.), or on a limited scale with macroinvertebrates (Martin et al. 1981).



Most such studies have also been within deciduous forest areas (e.g. Hubbard Brook). As a consequence, a study was conducted from autumn 1980 to autumn 1982 on the East Branch Piscataquis River, near Greenville, Maine. The stream is within a typical northeastern spruce-fir forest of the type described by Gibbs (1979).

The river is approximately 15 m wide in the affected area. A canopy of spruce and fir provided shading to approximately 90% of the stream surface prior to logging. About 90% of the standing timber was removed in the cut block, resulting in the removal of 70-80% of the canopy shading the stream. Pre-cutting measurements were conducted in 1981, and post-cutting measurements were conducted in 1982--a total of 24 months of study.

Details of the study have been reported by Garman (1984), but benthic particulate organic matter and suspended particulate matter significantly increased after logging, resulting in higher levels of sediment fines in the gravel of pools. Particulate organic matter in the stream was ten times higher after logging and the ratio of coarse to fine substrate particulates was reduced by almost 100 percent following cutting in the watershed.

Annual stream flow remained similar after cutting, but spring stream flow was higher following logging. Water temperatures were significantly higher after logging, and these alterations were linked to many of the biological changes. Mean daily temperature maxima were significantly greater in every month of 1982, exceeding 30°C (86°F) on several dates in summer. Waters warmed earlier and retained heat later in the year, probably due in part to supplemental warming of runoff across the clearcut area.

Insect and fish communities after logging were dominated by hardier species. Most groups were still represented after cutting, though mean annual densities of Plecoptera and Odonata were reduced, and eurythermal insects (e.g. *Oecetis*, *Cyrnellus*, and *Psilotreta*) increased in number. Brook trout disappeared from the stream, and non-game fishes (e.g. white sucker, *Catostomus commersoni*; northern redbelly dace, *Phoxinus eos*; blacknose dace, *Rhinichthys atratulus*; and creek chub, *Semotilus atromaculatus*) dominated the post-logging stream community. The common shiner (*Notropis cornutus*), not present prior to removal of riparian vegetation, became a significant component of the post-cutting fish population.

#### CONCLUSIONS

Intact riparian zones have several inherent values to aquatic systems. They insure stability and integrity of stream banks. Vegetation and root structures help to retain soil and reduce erosion to the stream. Intact riparian vegetation can also provide shading to streams, overhanging cover, terrestrial drift, and allochthonous drift for energy.

The study on the East Branch Piscataquis River demonstrated that many of the concerns expressed by riparian scientists in other parts of North America

hold for forested areas of Maine as well. It should be noted that, though 23 m (75 ft) intact riparian strips are often recommended for stream protection, wildlife biologists are often recommending even wider zones (as much as four times wider: Johnson and Small 1985), as riparian areas have value as animal corridors and winter deer yards. These terrestrial wildlife concerns extend beyond the immediate areas near streams.

The presence of intact riparian areas provides a "cushion" of protection for stream ecosystems. The riparian zone is a critical component for aquatic systems, and the alteration of that terrestrial zone can have serious implications to aquatic communities.

#### ACKNOWLEDGMENTS

This research was conducted in cooperation with the International Paper Company, and conducted on Company lands. Funding was principally from the Maine Department of Inland Fisheries and Wildlife, with additional grants from International Paper Company and the Evelyn Murphy Fund of the Appalachian Mountain Club. We appreciate the assistance and expertise of fishery biologists David Basley and Paul Johnson.

#### LITERATURE CITED

- Benke, A.C., and J.B. Wallace. 1980. Trophic basis of production among net-spinning caddis-flies in a southern Appalachian stream. *Ecology* 61:108-118.
- Beschta, R.L. 1979. Debris removal and its effects on sedimentation in an Oregon Coast Range Stream. *Northwest Science* 53:71-77.
- Bormann, F.H., T.G. Siccama, G.E. Likens, and R.H. Whittaker. 1970. The Hubbard Brook Ecosystem Study. *Ecological Monographs* 40:377-388.
- Bott, T.L., J.T. Brock, C.E. Cushing, S.V. Gregory, D. King, and R.C. Peterson. 1978. A comparison of methods for measuring primary productivity and community respiration in streams. *Hydrobiologia* 60:3-12.
- Brazier, J.R., and G.W. Brown. 1973. Buffer strips for stream temperature control. Forest Research Laboratory, Research Paper 15, 9p. Oregon State University, Corvallis, Oregon.
- Brown, G.W., and J.T. Krygier. 1967. Changing water temperatures in small mountain streams. *Journal of Soil and Water Conservation* 22:242-244.
- Brown, G.W., and J.T. Krygier. 1970. Effects of clearcutting on stream temperature. *Water Resources Research* 6:1133-1139.
- Brown, G.W., and J.T. Krygier. 1971. Clear-cut logging and sediment production in the Oregon Coast Range. *Water Resources Research* 7:1189-1198.
- Burns, J.W. 1972. Some effects of logging and associated road construction on northern California streams. *Transactions of the American Fisheries Society* 101:1-17.
- Chapman, D.W. 1962. Effects of logging upon fish resources of the west coast. *Journal of Forestry* 60:533-537.

- Cooper, A.C. 1965. The effect of transported stream sediments on the survival of sockeye and pink salmon eggs and alevins. International Pacific Salmon Fisheries Commission Bulletin 18, 17p. Vancouver, British Columbia.
- Englert, J., J.W.A. Grant, and B.F. Bietz. 1982. Impact of logging and associated practices on salmonid standing crop in the Maritimes. Environment Canada, Environmental Protection Services, Surveillance Report EP5-5-AR-82-4, Atlantic Region, 43p.
- Erman, D.C., and D. Mahoney. 1983. Recovery after logging in streams with and without bufferstrips in northern California. California Water Resources Center, Contribution 186, 50p. University of California, Berkeley, Calif.
- Erman, D.C., J.D. Newbold, and H.B. Roby. 1977. Evaluation of streamside bufferstrips for protecting aquatic organisms. California Water Resources Center, Contribution 165, 48p. University of California, Berkeley, Calif.
- Feller, M.C. 1981. Effects of clearcutting and slashburning on stream temperature in southwestern British Columbia. Water Resources Bulletin 17:863-867.
- Garman, G.C. 1984. Initial effects of deforestation on aquatic community structure and function of the East Branch Piscataquis River, Maine. Ph.D. Dissertation, 104p. University of Maine, Orono, Maine.
- Gibbs, C.B. 1979. Northeastern spruce-fir. p. 70-71 In *Silvicultural systems of the major forest types of the United States*. USDA Forest Service Agricultural Handbook 445, 114p. Washington, D.C.
- Gray, J.R.A., and J.M. Edington. 1969. Effect of woodland clearance on stream temperature. *Journal of the Fisheries Research Board of Canada* 26:399-403.
- Graynoth, E. 1979. Effects of logging on stream environments and faunas in Nelson. *New Zealand Journal of Marine and Freshwater Research* 13:79-109.
- Gurtz, M.E., J.R. Webster, and J.B. Wallace. 1980. Seston dynamics in southern Appalachian streams: effects of clearcutting. *Canadian Journal of Fisheries and Aquatic Sciences* 37:624-631.
- Hall, J.D., and R.L. Lantz. 1969. Effects of logging on the habitat of coho salmon and cutthroat trout in coastal streams. p. 355-375 In T.G. Northcote (editor), *Symposium on salmon and trout in streams*. H.R. MacMillan Lectures in Fisheries, 388p. University of British Columbia, Vancouver, British Columbia.
- Hall, R.J., G.E. Likens, S.B. Fiance, and G.R. Hendrey. 1980. Experimental acidification of a stream in the Hubbard Brook Experimental Forest, New Hampshire. *Ecology* 61:976-989.
- Hewlett, J.D., and J.C. Fortson. 1982. Stream temperature under an inadequate buffer strip in the southeast Piedmont. *Water Resources Bulletin* 18:983-988.
- Iwanaga, P.M., and J.D. Hall. 1973. Effects of logging on growth of juvenile coho salmon. U.S. Environmental Protection Agency, Report EPA-R3-73-006, 36p. Washington, D.C.
- Johnson, W.N., and M. Small. 1985. Wildlife management in riparian zones. *Proceedings of the Conference, Is Good Forestry Good Wildlife Management?*, Society of American Foresters, The Wildlife Society, and American Fisheries Society. (Portland, Maine, March 6-8, 1985): in press.
- Koski, K.V. 1966. The survival of coho salmon (*Oncorhynchus kisutch*) from egg deposition to emergence in three Oregon coastal streams. Master of Science Thesis, 84p. Oregon State University, Corvallis, Oregon.
- Krammes, J.S., and D.M. Burns. 1973. Road construction in Casper Creek watersheds. USDA Forest Service Research Paper PSW-93, 10p. Pacific Southwest Forest and Range Experiment Station.
- Likens, G.E., F.H. Bormann, N.M. Johnson, D.W. Fisher, and R.S. Pierce. 1970. Effects of forest cutting and herbicide treatment on nutrient budgets in the Hubbard Brook watershed ecosystem. *Ecological Monographs* 40:23-47.
- Lynch, J.A., G.B. Rishel, and E.S. Corbett. 1984. Thermal alteration of streams draining clearcut watersheds: Quantification and biological implications. *Hydrobiologia* 111:161-169.
- Maine Land Use Regulation Commission. 1979. A survey of erosion and sedimentation problems associated with logging in Maine. *Water Quality Planning Report*, submitted to Maine Department of Environmental Protection, 56p. Augusta, Maine.
- Martin, C.W., D.S. Noel, and C.A. Federer. 1981. The effects of forest clearcutting in New England on stream-water chemistry and biology. Technical Completion Report, Project A-051-NH, 76p. Water Resources Research Center, University of New Hampshire, Durham, N.H.
- Meehan, W.R. 1970. Some effects of shade cover on stream temperature in southeast Alaska. USDA Forest Service Research Note PNW-113, 9p. Pacific Northwest Forest and Range Experiment Station.
- Meehan, W.R., W.A. Farr, D.M. Bishop, and J.H. Patric. 1969. Some effects of clearcutting on salmon habitat of two southeast Alaska streams. USDA Forest Service Research Paper PNW-82, 45p. Institute for Northern Forestry, Pacific Northwest Forest and Range Experiment Station.
- Minshall, G.W. 1967. The role of allochthonous detritus in the trophic structure of a woodland spring brook stream. *Ecology* 48:139-149.
- Moring, J.R. 1975. *The Alsea Watershed Study: Effects of logging on the aquatic resources of three headwater streams of the Alsea River, Oregon. Part II - Changes in environmental conditions*. Oregon Department of Fish and Wildlife, Fishery Research Report 9, 39p. Corvallis, Oregon.
- Moring, J.R. 1981. Changes in populations of reticulate sculpins (*Cottus perplexus*) after clear-cut logging as indicated by downstream migrants. *American Midland Naturalist* 105:204-207.
- Moring, J.R. 1982. Decrease in stream gravel permeability after clear-cut logging: an indication of intragravel conditions for developing salmonid eggs and alevins. *Hydrobiologia* 88:295-298.
- Moring, J.R., and R.L. Lantz. 1974. Immediate effects of logging on the freshwater environment of salmonids. Oregon Wildlife Commission, Research Division, Federal Aid in Fish Restoration, Final Report for Project AFS-58, 101p.

- Moring, J.R., and R.L. Lantz. 1975. The Alsea Watershed Study: Effects of logging on the aquatic resources of three headwater streams of the Alsea River. Part I - Biological studies. Oregon Department of Fish and Wildlife, Fishery Research Report 9, 66p. Corvallis, Oregon.
- Mullen, D.M. 1985. The effects of deforestation on autochthonous energy input into a small New England trout stream. Master of Science Thesis, 36p. University of Maine, Orono, Maine.
- Murphy, M.L., and J.D. Hall. 1980. Effects of clearcutting on predators and their habitat in small streams of the Cascade Mountains, Oregon. Canadian Journal of Fisheries and Aquatic Sciences 37:123-134.
- Murphy, M.L., C.P. Hawkins, and N.H. Anderson. 1981. Effects of canopy modification and accumulated sediment on stream communities. Transactions of the American Fisheries Society 11:469-478.
- Narver, D.W. 1972. A survey of some possible effects of logging on two eastern Vancouver Island streams. Fisheries Research Board of Canada, Technical Report 323, 55p.
- Newbold, J.D., D.C. Erman, and K.B. Roby. 1980. Effects of logging on macro-invertebrates in streams with and without buffer strips. Canadian Journal of Fisheries and Aquatic Sciences 37:1076-1085.
- Phillips, R.W., R.L. Lantz, E.W. Claire, and J.R. Moring. 1975. Some effects of gravel mixtures on emergence of coho salmon and steelhead trout. Transactions of the American Fisheries Society 104:461-466.
- Platts, W.S. 1974. Stream channel sediment conditions in the South Fork Salmon River, Idaho. USDA Forest Service, Progress Report IV, 38p. Intermountain Region.
- Reed, R.D., and S.T. Elliott. 1978. Effects of logging on Dolly Varden trout. Alaska Department of Fish and Game, Annual Report, Federal Aid to Fish Restoration, Project F-9-4, 62p. Juneau, Alaska.
- Ringler, N.H., and J.D. Hall. 1975. Effects of logging on water temperature and dissolved oxygen in spawning beds. Transactions of the American Fisheries Society 104:111-121.
- Rothacher, J. 1970. Increases in water yield following clear-cut logging in the Pacific Northwest. Water Resources Research 6:653-658.
- Rowe, P.B. 1963. Streamflow increases after removing woodland - riparian vegetation from a southern California watershed. Journal of Forestry 61:365-370.
- Swank, W.T., and J.D. Helvey. 1970. Reduction of streamflow increases following regrowth of clear-cut hardwood forests. p. 346-360 In IASH - UNESCO symposium on the results of research on representative and experimental basins. (Wellington, New Zealand, December 1970).
- Verry, E.S., J.R. Lewis, and K.N. Brooks. 1983. Aspen clearcutting increases snowmelt and stormflow peaks in north central Minnesota. Water Resources Bulletin 19:59-66.
- Welch, H.E., P.E.K. Symons, and D.W. Narver. 1977. Some effects of potato farming and forest clearcutting on New Brunswick streams. Canadian Fisheries and Marine Service, Technical Report 745, 13p.

# The Fish Habitat Management Unit Concept for Streams on National Forests in Alaska<sup>1</sup>

Dave R. Gibbons<sup>2</sup>

---

Abstract.--The occurrence of alternatives invariably exists between the management of timber and fisheries resources. The concept of Fish Habitat Management Units (FHMU's) has been developed on National Forest Lands in Alaska to describe the specific streamside management requirements needed for the maintenance and improvement of aquatic resources. This paper discusses the development and management applications of FHMU's.

---

## INTRODUCTION

The impacts of timber harvesting on the habitat of salmonids vary from site to site, seasonally, and with the forest practices implemented. Spatial and temporal differences in the effects of logging on the hydrology of streams may be partially explained by climatic regimes, physiographic differences, and in the variations in the habits and life cycles of the stocks and species. Thus, a problem of specification exists, which prevents the universal application of standards. The continued vacuous use of direct regulations (i.e., water-quality standards) will eventually result in inefficiencies and inequities as they do not provide the necessary flexibility to balance the management between timber and fish. Prescriptions should be sufficiently flexible to allow for different levels and types of control from habitat to habitat and to optimize the forest and fish production from each site. An important step towards balancing these trade-offs was initiated in the Tongass Land Management Plan with the development of the concept of Fish Habitat Management Units (FHMU).

The Fish Habitat Management Handbook presented here further refines FHMU's into three classes: (1) anadromous and high quality resident fish habitat; (2) resident fish habitat; and (3) water quality. It provides guidance in facilitating fish habitat management through prescriptions while

---

<sup>1</sup> Paper presented at The Riparian Ecosystems and Their Management: Reconciling Conflicting Uses Conference, Tucson, Arizona, April 18, 1985.

<sup>2</sup> Regional Fisheries Program Manager, USDA Forest Service, Alaska Region, Juneau, AK.

addressing multiple-use objectives. While the handbook ensures a consistent approach is followed throughout the National Forest Lands in Alaska, it allows latitude, in site specific prescriptions to respond to regional habitat differences.

## FHMU DEVELOPMENT/DELINEATION

The concept of FHMU classes is based upon fish habitat management concerns and the possibility of potential impacts. Classes are determined according to the importance of the habitat to fish. These classes are defined as:

1. Class I FHMU Streams with anadromous fish habitat or a high value resident sport fisheries. Also included is the habitat upstream from migration barriers known to be reasonable enhancement opportunities. Stream gradient generally ranges from 0-6%.
2. Class II FHMU Streams with resident fish populations and 6-15% gradient (can also include streams from 0-6% gradient where no anadromous fish occur). These populations have limited sport fisheries values. They generally occur upstream of migration barriers or steep gradient streams and other habitat features that preclude anadromous fish use.
3. Class III FHMU Streams with no fish present but have potential water quality influence on downstream fish habitat. Stream gradient is usually in excess of 15% but may contain lower gradients.

The three classes are depicted in figure 1 and are determined in order of priority by: (1) a review of all existing data; (2) local knowledge; and (3) gradient.

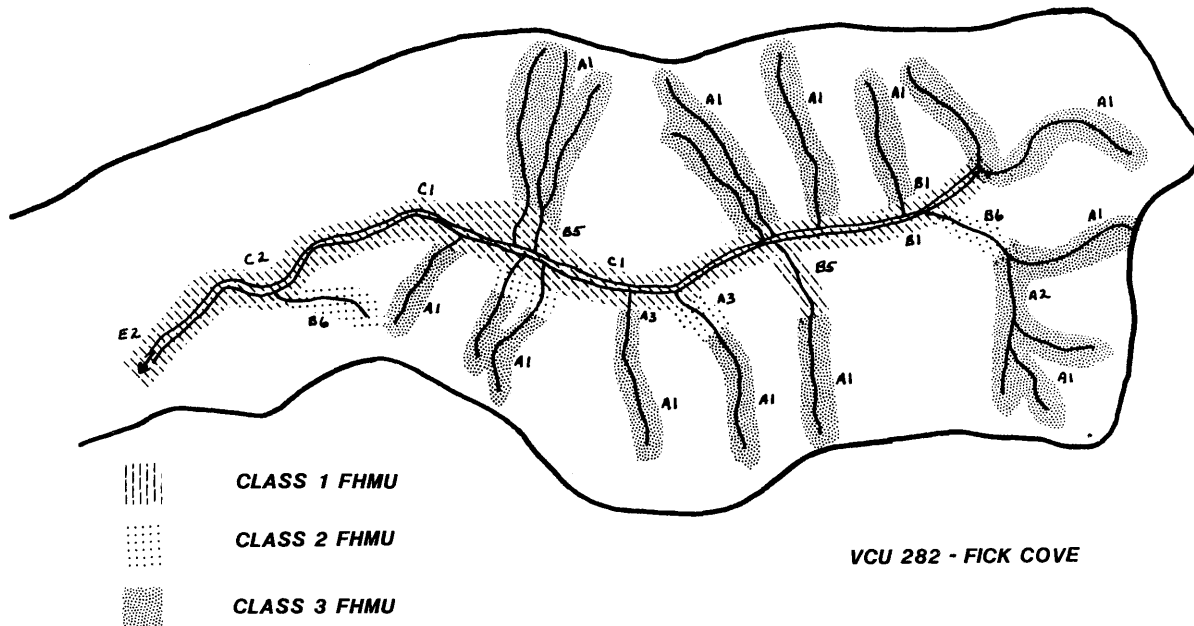

Figure 1. Value comparison unit (watershed) number 282 displaying class I, II and III FHMUs and channel types.

The magnitude and configuration is defined by channel type sensitivity (Rosgen 1985 and Paustian, Perkinson and Marion 1983) with a minimum width defined by the Alaska Regional Guide of 100 feet.

Salmonid habitat is complex but can be partially described using measurable physical elements. Maintenance of fish production centers on key habitat parameters such as proper water temperature, large organic debris, substrate composition and others. A precise blend of these key parameters creates good fish habitat.

When these key habitat parameters are related to the potential impacts from land management activities, they encompass seven fish habitat management concerns. These concerns are the link between the FHMU concept and the specific fish habitat management objectives and prescriptions. These concerns are listed in Table 1 and are related to FHMU class applicability.

The FHMU delineation has application to both broad level (allocation) and project level planning, however, only project level application will be discussed. The management guidance provided in the Handbook is organized within three levels. Class-I FHMUs have the most specifically defined, restrictive prescriptions, and Class-II and III respectively less restrictive. FHMU's require a range of management options from no cutting to complete harvest of commercial volumes of timber along streams. A brief discussion of the Class-I FHMUs seven fish habitat management concerns, and objectives follows.

Table 1. Frequency that fish habitat management concerns will result in prescriptions affecting land management activities

Management Concern	FHMU Classes		
	Class I	Class II	Class III
1. Maintenance of stream-bank and stream channel stability	1	1	1
2. Maintenance and/or enhancement of optimum stream temperature	1	1	2
3. Fish passage through stream crossing structures	1	2	3
4. Maintenance of water quality within established State standards	1	1	1
5. Maintenance of existing and providing future sources of large woody debris (LWD)	1	2	3
6. Maintenance or improvement of primary and secondary biological productivity within or adjacent to streams (including Second-Growth management).	1	3	3
7. Timing of bridge and culvert construction	2	3	3

1 - Always 2 - Occasionally 3 - Never

### Streambank and Stream Channel Stability

Objective. Maintain existing stream channel and bank conditions with specific reference to: (1) channel width-to-depth ratio; (2) pools and riffles (sequence, volume, and depth); (3) maintenance of 100% of undercut banks, stable debris, and other in-stream cover characteristics; and (4) avoiding stream sedimentation.

### Stream Temperature Sensitivity

Objective. Maintain average daily maximum summer temperatures below 58° on streams with baseline temperature below 58° F. On streams with normal, daily summer maximum temperatures in excess of 58° F, maintain unaltered summer maximum temperature (see appendix 740).

### Fish Passage Through Stream Crossings Structures

Objective. Maintain the natural migration of adult or juvenile anadromous and high-quality resident sportfish.

### Special Road Construction Mitigative Measures

Objective. Prevent siltation of spawning areas at or downstream of construction sites when eggs or young fish are in the substrate. Prevent mechanical damage to fish eggs or changing channel flow dynamics in the project vicinity.

### Maintenance of Water Quality Standards

Objective. Maintain water quality for the propagation of fish and other aquatic life as defined by the State of Alaska, Water Quality Standards, Feb. 1979, amended.

### Large Woody Debris

Objective. Provide, in perpetuity, future sources of large woody debris to aquatic habitats while maintaining and/or enhancing quantities of existing instream debris.

### Primary and Secondary Aquatic Production

Objective. Increase primary and secondary biological production in streams without adversely affecting juvenile salmonid habitat.

Class-II and III objectives will not be described but are less restrictive. Specific prescriptions to meet these objectives were developed by an Interdisciplinary Team (IDT) using data specific to southeast Alaska. Some of the most important references used to develop these standards are listed in the special literature cited section.

### IMPLEMENTATION/MONITORING

Once the specific prescriptions had been developed, procedures to insure implementation and monitoring were next developed. The "project input procedure" that was developed provides verification and record on the degree of desired fish habitat protection activity applied insitu after preparation of the timber sale Environmental Analysis and selection of the preferred alternative. A format for documentation of input was established. The input procedures are directly linked to the Land Management activity such as timber harvest and road construction. The procedures additionally provide a permanent reference for subsequent monitoring and land management actions.

The monitoring procedure tracks management accomplishments. The effectiveness of any proposed fish habitat management prescription is only as good as its on-the-ground implementation. Implementation efficiency of a timber sale for example is the degree to which the prescribed management activities have been carried out from planning through completion. If management prescriptions are not properly administered, the planned activities will be incomplete and detrimental fish habitat impacts may occur. The monitoring procedure (implementation efficiency analysis) established is aimed at: (1) determining if the prescriptions were implemented and objectives subsequently met and (2) providing a mechanism for modifying the prescriptions to meet the objectives. Figure 2 depicts a representative timber sale implementation efficiency analysis.

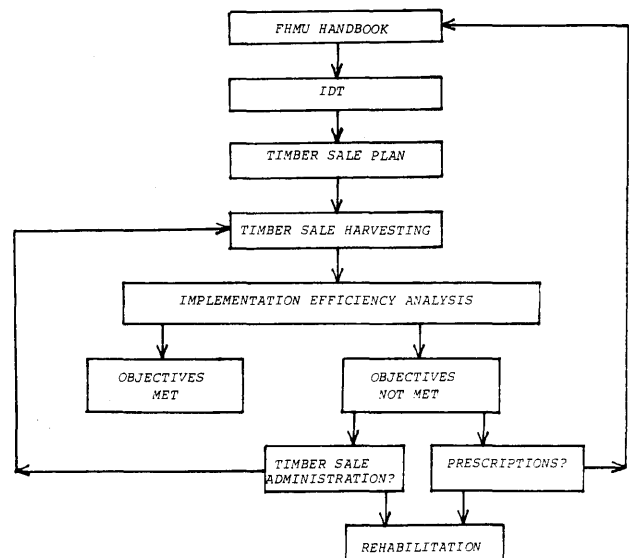

Figure 2. Implementation efficiency analysis.

## DISCUSSION

Today in Southeast Alaska, resource managers are confronted with the responsibilities of making many significant decisions relating to the future use of Alaska's renewable natural resources. In the past 10 years, increased public attention has focused on critical environmental issues affecting the use of many natural resources, including timber and fish. Timber and fish are the two resources with the greatest present economic value in Southeast Alaska, and since, in many instances, each watershed produces both resources, it is inevitable that conflicts will arise when resource decisions are made in favor of one resource over the other. These potential conflicts which can arise from unaltered maintenance of streamside vegetation, culvert construction to pass salmonids and others) will continue to occur as demands increase for a variety of goods and services produced from a static or declining land base. It is not a question of fish or timber since both resources are highly used, but rather integration of management and effective use of existing guidelines. As Martin (1976) points out, timber harvesting/fisheries issues are not simple to answer, but can only be resolved through proper application of existing knowledge, and for the most part, by the application of existing laws, regulations, and management guidelines. Recent legislative activities, special interest group pressures, judicial rulings, standards and prescriptions promulgated by private conservation groups, state and federal land management agencies provide ample evidence that the resolution of the timber/fisheries conflicts is one of our current pressing problems.

It is clear that one of the major problems concerning timber and fisheries management involves the management itself: namely, the effective application of existing guidelines and continued development of sound resource guidelines and techniques. Many past management guidelines have been developed for southeast Alaska as a result of studies on the effects of timber harvesting on fish, water and soil throughout the Pacific Northwest. The new tiered prescriptions described are principally based upon recent research in southeast Alaska. These prescriptions expand upon standards and guidelines in the TLMP and the Alaska Regional Guide providing the impetus and direction toward providing greater protection.

Economic theory (Freeman et al. 1973) suggests that optimal management strategy is to minimize externalities, such as human-caused sedimentation, to levels at which the costs of further constraints will not balance the expected benefits. Other considerations (i.e., fisheries and wildlife) in land-use plans and

decisions have long been treated as constraints. Under optimization techniques, these other considerations are treated as an equal objective, side by side with all other concerns. This component of equal consideration is prescribed in the Alaska Regional Guide (USDA Forest Service 1983). Equal resource consideration, maximized with the use of the Fish Habitat Management Handbook, will provide a viable system, which can be used to both manage timber and fisheries production in southeast Alaska.

## LITERATURE CITED

- Freeman, A., R. Haveman, and A. Kneese. 1973. The economics of environmental policy. John Wiley and Sons Inc., New York. 439 pp.
- Martin, D. J. 1976. The effects of sediment and organic detritus on the production of benthic macroinvertebrates in four tributary streams of the Clearwater River, Washington. Unpublished M.S. Thesis, Univ. Wash., Seattle. 79 pp.
- Paustian, Steven J., Douglas Perkinson, Daniel A. Marion. 1983. An aquatic value rating procedure for fisheries and water resource management in southeast Alaska. USDA Forest Service, Admin. Rept. Sitka, AK 29 pp.
- Rosgen, Dave. A stream classification system. Presented at N. Amer. Riparian Conf., April 16-18, 1985. Tucson, AZ.
- USDA Forest Service. 1983. Alaska Regional Guide Report. No. 126. Juneau 112 pp. and 11 appendices.

## Prescription Developing References

- Anderson, L. and M. Byrant. 1980. Fish passage at road crossings: an annotated bibliography. USDA Forest Service, Pac. N.W. Forest and Range Expt. Sta., Gen. Tech. Rept. PNW-117. Portland, OR. 10 pp.
- Bryant, M. D. 1983. The role and management of woody debris in west coast salmonid nursery streams. N. Amer. J. Fish. Mgmt. 3:322-330.
- Bryant, M. D. 1981. Evaluation of a small diameter baffled culvert for passing juvenile salmonids. USDA Forest Service, Pac. NW Forest and Range Expt. Sta., Research Note PNW-384. Juneau, AK 8 pp.

- Bryant, M. D. 1981. Organic debris in salmonid habitat in southeast Alaska: measurement and effects. *In: Proc. Symposium on Acquisition of Aquatic Habitat Inventory Information* p. 259-265. Amer. Fish. Soc., Portland, OR.
- Bryant, M. D. 1980. Evolution of large organic debris after harvest: Maybesco Creek 1949-1978. USDA Forest Service, Pac. NW Forest and Range Expt. Sta., Gen. Tech. Rept PNW-101. Portland, OR. 30 pp.
- Dolloff, C. A. 1983. The relationship of wood debris to juvenile salmonid production and microhabitat selection in small southeast Alaska streams. Ph.D. Dissertation. Montana State Univ., Bozeman. 100 pp.
- Elliott, S. T. 1983. The summer standing crop of juvenile coho salmon in southeastern Alaska streams logged during the 1960's. Alaska Department of Fish and Game Report to the Alaska Working Group on Cooperative Forestry/Fisheries Research. November 21, 1983. Juneau. 7 pp.
- Elliott, Steven and Dennis Hubartt. 1978. Study of land use activities and their relationship to sport fish resources in Alaska. Alaska Dept. Fish and Game, Annual Performance Rept., Study No. D-I, Vol. 19. Juneau. 51 pp.
- Gibbons, Dave R. 1982. A streamside management plan for the protection of salmonid habitat in southeast Alaska. Ph.D. Dissertation, Univ. Washington. Seattle. 166 pp.
- Heifetz, J., M. L. Murphy, and K. V. Koski. In press. Effects of logging on winter habitat of juvenile salmonids in Alaska streams. *N. Amer. Jour. Fish. Mgmt.* 6(1).
- Meehan, W. R. 1970. Some effects of shade cover on stream temperatures in southeast Alaska. USDA Forest Service, Res. Note PNW-113. Portland, OR. 9 pp.
- Meehan, W. R. 1974. The forest ecosystems of southeast Alaska - 3. fish habitat. USDA Forest Service, Gen. Tech. Rept., PNW-15. Portland, OR. 41 pp.
- Meehan, William R. and Douglas N. Swanston. 1977. Effects of gravel morphology on fine sediment accumulation and survival of incubating salmon eggs. USDA Forest Service, Res. pap. PNW-220. Portland, OR. 16 pp. and Illus.
- Meehan, William R., Fredrick J. Swanson, and James R. Sedell. 1977. Influences of riparian vegetation on aquatic ecosystems with particular reference to salmonid fishes and their food supply. *In: A Symposium on the Importance, Preservation and Management of Riparian Habitat.* p. 137-145. Tucson, AZ.
- Murphy, Michael L. 1983. Relationship between rearing salmonids and stream habitat account for effects of logging in southeastern Alaska. Northwest and Alaska Fisheries Center, Auke Bay Laboratory, Juneau, AK. Unpublished Report.
- National Marine Fisheries Service. 1983. Effectiveness of buffer zones in protection fish habitat in small streams during clearcut logging in southeastern Alaska. Executive Summary, Auke Bay Laboratory, Watershed and Estuarine Ecosystems Project. Juneau, AK 13 pp.
- Sheridan, W. L. 1977. The temperature sensitive stream. USDA Forest Service, Adm. Report, R-10. Juneau. 8 pp.
- Sheridan, W. L. and A. M. Bloom. 1975. Effects of canopy removal on temperatures of some small streams in southeast Alaska. USDA Forest Service, Adm. Report, R-10. Juneau. 12 pp.
- Swanston, D. N., W. R. Meehan and J. A. McNutt. 1977. A quantitative geomorphic approach to predicting productivity of pink and chum salmon streams in southeast Alaska. USDA Forest Service, Res. Pap. PNW-227, Portland, OR. 16 pp.
- Tyler, R. W. and Dave R. Gibbons. 1973. Observations of the effect of logging on salmon producing tributaries of the Stoney Creek watershed and the Thorne River watershed. F.R.I., Univ. of Washington, Final Report to Alaska Loggers Association. Seattle. 58 pp.
- USDA Forest Service. 1979. Roadway drainage guide for installing culverts to accommodate fish. Eng. and Aviation Management Div., Alaska Region Rept. No. 42. Juneau. 121 pp.



# Importance and Evaluation of Instream and Riparian Cover in Smaller Trout Streams<sup>1</sup>

Thomas A. Wesche<sup>2</sup>  
Chris M. Goertler  
Carrie B. Frye

Cover is an important trout habitat component resulting from the geomorphological characteristics of a stream channel, the streambank interface with the riparian community, and the streamflow. This paper quantitatively describes the significance of the riparian contribution to overall stream cover as related to brown trout population size.

## INTRODUCTION

Cover is an important trout habitat component resulting from the geomorphological characteristics of a stream channel, the streambank interface with the riparian community, and the streamflow. In recent years, numerous habitat models have included cover measurement as part of the overall evaluation process. These models include the Habitat Quality Index (Binns, 1982), the Instream Flow Incremental Methodology (Bovee, 1982), the Habitat Suitability Index Models for brown trout (Raleigh, Zuckerman and Nelson, 1984), the Bureau of Land Management Stream Habitat Survey (Duff and Cooper, 1976) and the General Aquatic Wildlife System of the U.S. Forest Service, Region 4 (Duff, 1981).

Trout cover in smaller streams has been described by Wesche (1973, 1974 and 1980) as consisting of three primary components: 1) instream rubble and boulder areas having a substrate particle diameter of 7.6 cm or greater in association with water depth of at least 15 cm; 2) overhead bank cover, including undercut banks, overhanging vegetation, logs and debris jams, having effective widths of 9 cm or greater in association with water depths of at least 15 cm; and, 3) deep pool areas having water depths of at least 45 cm. These components were identified based upon the escape cover preferences of approximately 2,300 trout (62% brown trout) sampled by electrofishing. Combining these components into unitless, additive equations and incorporating weighing factors based upon trout

preferences for different cover types, two models for cover evaluation were developed and tested against trout standing crops (Wesche, 1980).

The objective of this paper will be to summarize the application and evaluation of these two Cover Rating Models, stressing the important contribution of riparian vegetation to the availability of cover in small trout streams.

## DESCRIPTION OF STUDY AREAS

The results presented in this paper are based upon field investigations made at 27 study sites in 11 reaches of 8 montane and foothills streams located in the North Platte River Basin of south-east Wyoming. Brown trout (*Salmo trutta*) was the predominant game fish species present at all study sites, comprising 61% to 100% of the total trout populations, on a numbers basis. Lesser numbers of brook (*Salvelinus fontinalis*) and rainbow trout (*Salmo gairdneri*) were collected at certain of the sites. Trout standing crops were found to range from 8.0 to 210.6 Kg/Ha.

Mean elevations of the study sites ranged from 1615 to 2835 m above mean sea level, while average discharges through the reaches varied from approximately 0.3 to 4.5 m<sup>3</sup>/sec. Site lengths averaged 140 m (range of 73 to 253 m). Study reaches, the combination of several adjacent sites, had a mean length of 340 m with a range from 134 to 629 m. Stream widths varied from 2 to 23 m.

More detailed descriptions of the study streams can be found in Wesche (1973, 1974 and 1980).

## METHODS

Trout standing crop estimates were made at each study site by means of electrofishing using the three-pass removal method described by Zippin (1958). Block nets were placed at the upper and lower ends of each site prior to sampling to prevent fish migration.

<sup>1</sup>Paper presented at the North American Riparian Conference, Tucson, Arizona, April 16-18, 1985.

<sup>2</sup>Thomas A. Wesche is Senior Research Associate, Chris M. Goertler is Research Associate I, and Carrie B. Frye is Research Assistant at the Wyoming Water Research Center, University of Wyoming, Laramie, Wyoming.

Available trout cover was measured at each study site using the Cover Rating Method described by Wesche (1973, 1974 and 1980). The equation for Model I of this method is of the form:

$$CR = \frac{L_{obc}}{T} (PF_{obc}) + \frac{A_{r-b}}{SA} (PF_{r-b})$$

where  $L_{obc}$  = length of overhead bank cover in the study section having a water depth of at least 15 cm and an effective width of 9 cm or greater;

$T$  = length of the thalweg line through the section;

$\frac{L_{obc}}{T}$  = percent overhead bank cover;

$PF_{obc}$  = preference factor of brown trout for overhead bank cover;

$A_{r-b}$  = surface area of the study section having water depths greater than 15 cm and substrate size 7.6 cm in diameter or greater (i.e., rubble and boulder) or a substrate covered with aquatic vegetation;

$SA$  = total surface area of the study section;

$\frac{A_{r-b}}{SA}$  = percent rubble-boulder area;

$PF_{r-b}$  = preference factor of brown trout for instream rubble-boulder-aquatic vegetation areas; and

$CR$  = cover rating value for the study section at the discharge worked.

While Model I was developed for use primarily on smaller streams (average discharge less than 2.75 m<sup>3</sup>/sec), a deep water component was included in Model II to increase the applicability of the method to larger habitats. The equation for Model II is as follows:

$$CR = \frac{L_{obc}}{T} (PF_{obc}) + \frac{A_{r-b}}{SA} (PF_{r-b}) + \frac{Ad}{SA}$$

where  $CR$ ,  $L_{obc}$ ,  $T$ ,  $PF_{obc}$ ,  $A_{r-b}$ ,  $SA$ , and  $PF_{r-b}$  are exactly the same as defined above for Model I, and

$Ad$  = surface area of the study section having a water depth of 45 cm or greater regardless of substrate or adjacent bankside cover.

$Ad/SA$  = percent deep water area.

Step-by-step procedures for applying the two models are provided in Wesche (1980).

Simple and multiple regression analysis of the relationships between the two cover models and the three individual cover components (independent variables) and trout standing crops (dependent variable) were performed using the ABSTAT package on the Wyoming Water Research Center's CompuPro computer system.

## RESULTS

The results of the regression analysis testing the relationships between the independent cover variables (Cover Rating Model I, Cover Rating Model II, percent rubble-boulder cover area, percent overhead bank cover, and percent deep-water cover) and the dependent variable, Kg/Ha of trout, are presented in Table 1 for the site data. The analysis by study reach is provided in Table 2.

Three cover variables (Model I, Model II and percent overhead bank cover), were found to have a statistically significant positive linear relationship with trout standing crop when considered on a site basis. Of the three, percent overhead bank cover was found to explain the greatest amount of variation among the trout populations sampled, 39 percent. Also, the regression using this cover variable had the smallest standard error, 42.5 percent.

The results of the analysis on a study reach basis (Table 2) indicate that two of the cover variables, Model I and percent overhead bank cover, were found to have statistically significant positive correlation coefficients when regressed against trout standing crop. As with the site analysis, percent overhead bank cover was the independent variable found to explain the greatest amount of variation among the trout populations sampled, 63 percent. Also, the standard error of the estimate using percent overhead bank cover was again the lowest, 25.4 percent.

Multiple regression analysis on a study site basis using percent rubble-boulder area (%  $A_{r-b}$ ), percent overhead bank cover (% OBC) and percent deep water cover (% Ad) as the independent variables yielded the following equation:

$$Y(\text{Kg/Ha}) = 38.31 - 32.45 (\% A_{r-b}) + 108.31 (\% \text{OBC}) + 46.93 (\% \text{Ad})$$

This relationship explained 40 percent of the variation in trout standing crops with a 44.2 percent standard error of estimate, only slightly improved over the simple regression relationship found when using just percent OBC.

Similar results were obtained with multiple regression analysis on a reach basis. The equation developed was:

$$Y(\text{Kg/Ha}) = 0.67 - 5.16 (\% A_{r-b}) + 192.58 (\% \text{OBC}) + 74.72 (\% \text{Ad})$$

Table 1. Regression statistics for brown trout streams, by sites, using trout biomass (Kg/Ha) as the dependent variable.

<u>Independent Variable</u>	<u>n</u>	<u><math>\bar{X}</math></u>	<u><math>\bar{Y}</math></u> (KG/Ha)	<u>a</u>	<u>b</u>	<u>r</u>	<u>R<sup>2</sup></u>	<u>F</u>	<u>T</u>	<u>Standard Error of Estimates</u>
Cover Rating (Model I)	27	0.30	68.4	-5.60	235.46	0.56**	0.31	11.22**	3.35**	45.1
Cover Rating (Model II)	25	0.47	72.2	19.46	112.20	0.51**	0.26	8.18**	2.86**	47.0
% Rubble-Boulder Cover Area	26	0.30	70.2	104.84	-117.02	-0.37	0.14	3.92	-1.98	50.6
% Overhead Bank Cover	26	0.33	70.2	24.14	137.91	0.63**	0.39	15.54**	3.94**	42.5
% Deep Water Cover	25	0.15	72.2	51.86	136.93	0.38	0.14	3.89	1.97	50.6

\*Statistically significant at = .05

\*\*Statistically significant at = .01

Table 2. Regression statistics for brown trout streams, by reach, using trout biomass (Kg/Ha) as the dependent variable.

<u>Independent Variable</u>	<u>n</u>	<u><math>\bar{X}</math></u>	<u><math>\bar{Y}</math></u> (KG/Ha)	<u>a</u>	<u>b</u>	<u>r</u>	<u>R<sup>2</sup></u>	<u>F</u>	<u>T</u>	<u>Standard Error of Estimates</u>
Cover Rating (Model I)	11	0.32	76.3	-28.21	330.33	0.62*	0.39	5.72*	2.39*	32.7
Cover Rating (Model II)	11	0.47	76.3	12.53	136.73	0.54	0.29	3.71	1.93	35.2
% Rubble-Boulder Cover Area	11	0.28	76.3	113.77	-132.15	-0.53	0.28	3.51	-1.87	35.5
% Overhead Bank Cover	11	0.34	76.3	6.78	202.81	0.79**	0.63	15.43**	3.93**	25.4
% Deep Water Cover	11	0.15	76.3	61.36	100.66	0.32	0.10	1.04	1.02	39.6

\*Statistically significant at = .05

\*\*Statistically significant at = .01

While this equation explained 69 percent of the variation in trout standing crop with a standard error of 26.5 percent, these results were only slightly improved over the simple regression equation developed using only percent OBC.

#### CONCLUSIONS

1) Based upon the results presented, it is evident that riparian vegetation contributes significantly to the amount of cover available in smaller trout streams and to the brown trout carrying capacity of these streams. Not only does the vegetation directly provide cover by creating quiet, shaded resting areas where it comes in contact with the water surface (overhanging vegetation) and by contributing material to debris jams, but also the roots of these plants are critical to the development and maintenance of undercut banks. Without this stabilizing influence and natural means of sediment control, trout cover would also be lost through the filling of pools and the embedding of larger substrate particles.

2) While the cover variables percent deep-water cover, percent rubble-boulder area, and Cover Rating Models I and II were not as strongly correlated with brown trout standing crop as was percent OBC, Wesche (1980) and Eifert and Wesche (1982) found these variables to be significant when dealing with larger brown trout streams and with brook trout streams. Thus, given the diversity of cover within stream systems, the investigators feel these variables can be useful for trout cover evaluations.

3. While the cover variables measured in this study are unitless and can be applied to any length of stream section, the data tend to indicate that the longer the reach investigated, the more reliable and meaningful will be the results. Additional study is needed in this area.

#### LITERATURE CITED

- Binns, N.A. 1982. Habitat Quality Index procedures manual. Wyoming Game and Fish Department, Cheyenne, WY. 209 pp.
- Bovee, K.D. 1982. A guide to stream habitat analysis using the Instream Flow Incremental Methodology. Instream Flow Information Paper No. 12. USDI Fish and Wildlife Service, Office of Biological Services. FWS/OBS-82/26. 248 pp.
- Duff, D.A. 1981. General Aquatic Wildlife System (GAWS). Proceedings of Symposium on Acquisition and Utilization of Aquatic Habitat Inventory Information, American Fisheries Society, Western Division, Portland, OR. pp. 291-293.
- Duff, D.A. and J.L. Cooper. 1976. Techniques for conducting stream habitat surveys on National Resource Land. BLM Technical Note, Denver, CO. 72 pp.
- Eifert, W.H. and T.A. Wesche. 1982. Evaluation of the Stream Reach Inventory and Channel Stability Index for instream habitat analysis. Water Resources Series Publ. No. 82, Univ. of Wyoming, Laramie, WY. 106 pp.
- Raleigh, R.F., L.D. Zuckerman, and P.L. Nelson. 1984. Habitat suitability index models and instream flow suitability curves: Brown trout. U.S. Fish and Wildlife Service FWS/OBS-82/10.71. 71 pp.
- Wesche, T.A. 1973. Parametric determination of minimum streamflow for trout. Water Resources Series Publ. No. 37, Univ. of Wyoming, Laramie, WY. 102 pp.
- \_\_\_\_\_. 1974. Relationship of discharge reduction to available trout habitat for recommending suitable streamflows. Water Resources Series Publ. No. 53, Univ. of Wyoming, Laramie, WY. 71 pp.
- \_\_\_\_\_. 1980. The WRR I Cover Rating Method - development and application. Water Resources Series Publ. No. 78, Univ. of Wyoming, Laramie, WY. 46 pp.
- Zippin, C. 1958. The Removal Method of population estimation. J. Wildl. Manage. 22(1):82-90.

# Changes 30 Years After Logging in Large Woody Debris, and Its Use by Salmonids<sup>1</sup>

Mason D. Bryant<sup>2</sup>

---

**Abstract.**—Changes in large woody debris in fourth and fifth-order salmon streams with logged, unlogged, and partially logged riparian zones are documented from maps—for 1949 to 1960—and from field surveys done in 1983 and 1984. Over the 30-year period, most changes in the amount of large woody debris occurred in the logged systems. During and immediately after logging large increases were noted, but in 1984 the amount of large woody debris in the logged systems was less than that observed before logging in most categories. Amounts of large woody debris in the other streams remained relatively stable. Thirty years after logging, habitat formed as a result of large debris provides important rearing areas for juvenile salmonids. Results from this study emphasize the importance of managing riparian zones as a source of large organic debris.

---

Large woody debris is an important component in the habitat used by juvenile salmonids and the riparian zone is the primary source of large woody debris (Dolloff 1983, Elliott and Hubartt 1978, Sedell and Luchessa 1981). Streams flowing through old-growth forest systems typically contain numerous accumulations of tree-size material (Swanson et al. 1976, 1984). This material enters as a result of floods, bank scour and blowdown (Heede 1972, Keller and Swanson 1979, Moore 1977, Toews and Moore 1982). Because large-scale logging in the riparian zone can eliminate the source of large woody debris, the amount, type, and rate of entry into streams of large woody debris may change following logging.

Immediately following logging, the density and number of large woody debris accumulations increased and stability of debris decreased in Carnation Creek, British Columbia (Toews and Moore 1982), and in Maybeso Creek in southeast Alaska (Bryant 1980). In Maybeso Creek an overall decrease in the number of accumulations was observed 20 years after logging. Other studies in first- and second-order streams report higher densities of both fine (<10-cm diameter) and coarse (>10-cm diameter) woody debris and destabilization of the stream channel in streams flowing through recently logged areas was observed 20 years after logging. Other studies in first- and second-order streams report higher densities of both fine (< 10-cm diameter) and

coarse (> 10-cm diameter) woody debris and destabilization of the stream channel in streams flowing through recently logged areas (Bilby 1984, Bryant 1981, Swanson et al. 1984).

Dolloff (1983) and Elliott and Hubartt (1978) show that woody debris is an important factor in maintaining productive salmonid habitat in small streams in southeast Alaska. Dolloff (1983) showed a decrease in coho salmon (*Oncorhynchus kisutch*) production following debris removal in second-order tributaries. Bustard and Narver (1975) demonstrated the use of woody debris as winter habitat for juvenile coho salmon in British Columbia streams. Bisson and Sedell (in press) show similar effects of debris on the habitat of juvenile coho salmon in small streams in Washington. The effects of logging in the riparian zone on the relation of large woody debris to salmonid habitat has not been studied in the larger stream systems of southeast Alaska.

The objectives of this study are to (1) document changes in the number of debris accumulations following logging, (2) identify the effects of changes in the number of large woody debris accumulations on channel morphology, and (3) determine the use of accumulations of large woody debris by juvenile salmonids in fourth- and fifth-order streams.

## METHODS

### Study Area

Five fourth- and fifth-order streams on the east coast of Prince of Wales Island, approximately 100 km northwest of Ketchikan, Alaska, were selected for study (fig. 1). The streams flow directly into the salt water.

---

<sup>1</sup> Paper presented at Riparian Ecosystems and their Management. [Tucson, Arizona, April 16-18, 1985]

<sup>2</sup> Research Fishery Biologist, USDA Forest Service Pacific Northwest Forest and Range Experiment Station, Forestry Sciences Laboratory, Juneau, Alaska.

The riparian zone of each stream has been affected differently by land management activity (table 1). The Old Tom Creek drainage has not been logged; the riparian zones of the Harris River and Maybeso Creek study sections were completely logged in the early 1950's; the Twelve-Mile Creek watershed has been extensively logged at various times since the late 1950's, but a fringe of noncommercial timber was left along the stream. The lower 1000 m of the Indian Creek study section has been partially logged.

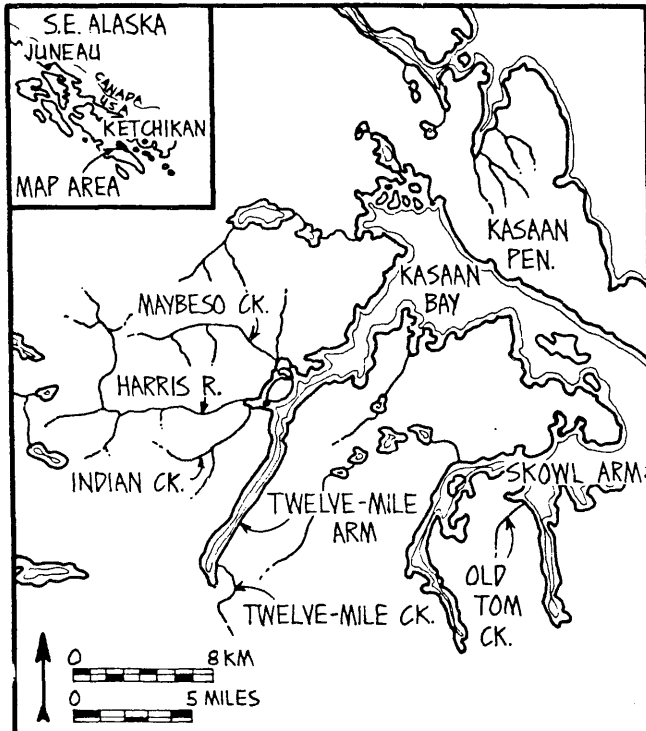

Figure 1.--Location of study streams, Prince of Wales Island, Alaska.

#### Sampling and Data Base

The five study streams were selected because each had been accurately mapped in the 1950's; most were first mapped in 1949, before logging. The maps showed the stream course, significant morphological features--bedrock, gravel bars, pools--and accumulations of large woody debris. The maps began at the intertidal zone and continued upstream 3 to 5 km. They provided the data base for changes in channel morphology and number of debris accumulations from 1949 through logging during the 1950's. In 1983 and 1984, the sections of the streams that had been mapped in 1949 were located and debris accumulations were counted in each section. Because different lengths of stream were mapped, the debris counts, by category, are reported as number of accumulations per kilometer of stream.

Large woody debris was defined as material > 2 m in length with one end > 30 cm in diameter; this included most tree-size material and excluded slash and branches. Sizes of accumulations were categorized as: (1) 1-4 pieces; (2) 5-10 pieces;

Table 1.--Physical characteristics of the five study streams.

Stream	Length	Area	Discharge <sup>1</sup>	25 yr	Riparian
				Flood Event	
	(km)	(km <sup>2</sup> )	(m <sup>3</sup> /sec)	(m <sup>3</sup> /sec)	Zone
Harris River	14.0	74.6	7.24	285.9	Logged to bank
Maybeso Creek	10.0	39.3	3.86	113.7	Logged to bank
Indian Creek	8.5	22.9	2.43	172.5	Logged lower 2 km, old-growth upper section
Twelve-Mile Creek	11.7	29.6	2.28	91.6	Logged with fringe mostly non commercial conifer
Old Tom Creek	3.4	15.3	1.06	21.7	Old growth

<sup>1</sup>Average per year

and (3) more than 10 pieces. Although the categories were arbitrary, they provided a measure of small, medium, and large accumulations and were easily identified on the maps and during on-the-ground surveys in 1984.

Study sites approximately 100 m long were selected on each stream for remapping and sampling of salmonid populations. Each stream included habitat with no debris, and habitat with accumulations in each of the three categories described above. Some habitat types were continuous, but divided by a naturally occurring feature such as rapids, a riffle, or a gravel bank.

Salmonid populations were sampled with 3.1-mm (1/8-in) mesh wire minnow traps baited with salmon eggs. Traps were set for at least 1 hour at each location. Each fish was measured and marked with a small hole in the caudal fin. Differential marks were used in contiguous sections to detect fish movement. Traps were reset the following day to recapture marked fish. Population size was estimated with the Bailey modification of the Peterson estimate (Ricker 1975). Estimates of coho salmon fry (less than or equal to 55 mm total length) and of age 1+ coho (> than 55 mm) were computed separately.

#### RESULTS

##### Changes in Debris Loading

The number of accumulations of large woody debris increased from 1949 to 1952. This may be attributed to additional accumulations that were missed during mapping in the previous year. At the onset of logging, however, obvious changes were

detected and all categories of large woody debris increased in the affected streams.

In 1952 (before logging), Twelve-Mile Creek, Maybeso Creek, and Old Tom Creek consistently had more large woody debris in all three categories (fig. 2). The greatest changes occurred in Harris River and Maybeso Creek. In 1960, after these two watersheds had been logged, the number of accumulations of 10 or more pieces more than doubled. A similar increase occurred in Old Tom Creek--an undisturbed system--but as a result of blowdown.

The accumulations in the Harris River and Maybeso Creek were usually composed of logging residue-- cut rootwads, logs, and snags--that was trapped by smaller debris accumulations. In Maybeso Creek, this resulted in a decrease in the 5- to 10-piece category and an increase in the 10+ category. By 1984 the number of accumulations in all categories of large woody debris in the systems with logged riparian zones was less than the number observed before logging except for the 10+ category in the Harris River. The number of accumulations of large woody debris in Twelve-Mile Creek, the system with an unlogged riparian zone, remained

relatively stable throughout the 30-year period. The Indian Creek drainage was unlogged in the upper section but generally contained few large woody debris accumulations; the decrease in the number of accumulations of large woody debris from 1960 to 1980 may be attributed to removal of debris and straightening the stream channel in the lower section during the 1960's to enhance spawning areas for pink salmon (*O. gorbuscha*).

Blowdown and stream braiding appeared to be responsible for most of the larger accumulations before logging. Generally once a section of stream had been exposed to blowdown and braiding, the effects remained over the 30-year period. Some important differences appeared between large woody debris accumulations in streams with logged and unlogged riparian zones. These differences are caused by the complete removal of large trees along the stream bank and to large amounts of unstable, floatable material, consisting of cut rootwads, logs, and cut snags left by logging.

Most of the sections of Old Tom Creek with accumulations of four or more pieces continued to show the effects of blowdown 30 years later. Changes in channel morphology occurred, but most pieces of large woody debris remained in place (fig. 3). In 1949 a remnant channel was evident,

DEBRIS ACCUMULATION BY CLASS

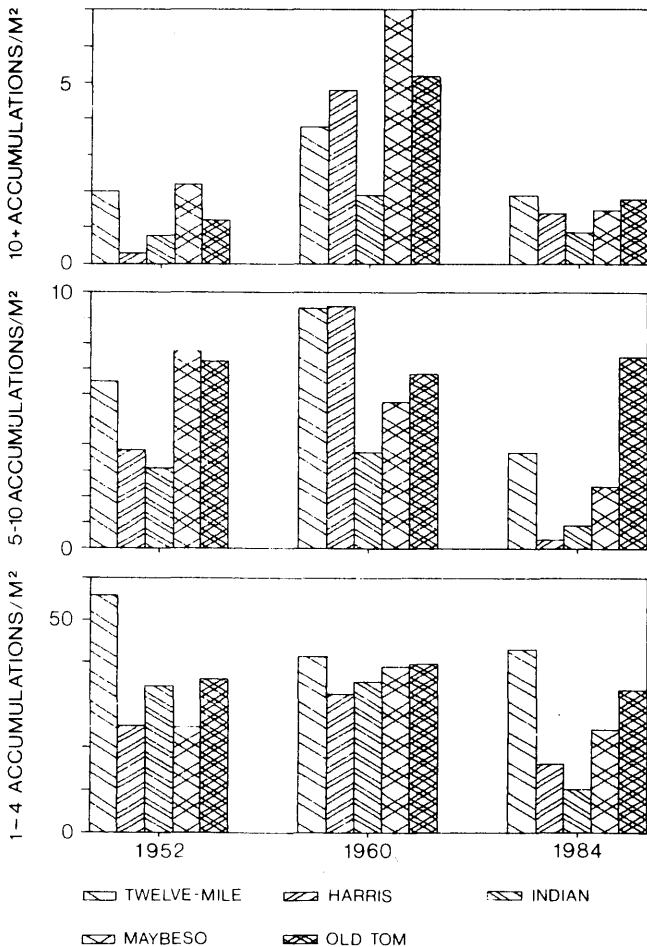

Figure 2.--Relative densities of the three categories of LWD for 1953, 1960, and 1984 in the 5 study streams.

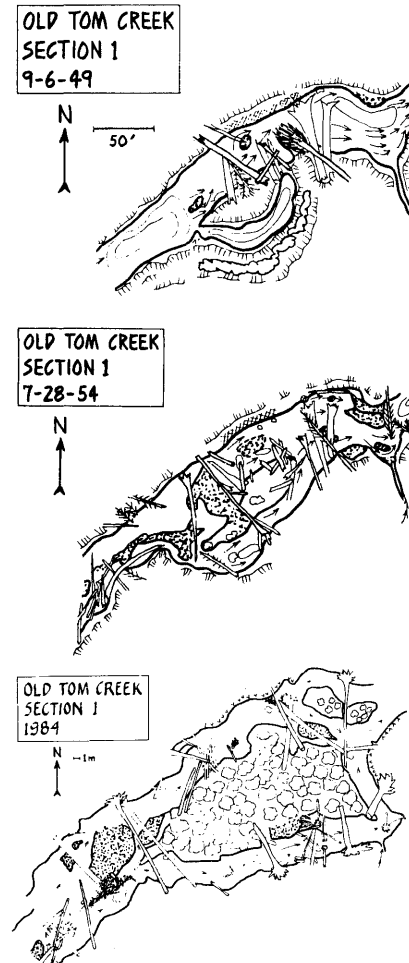

Figure 3.--Change in channel morphology of Old Tom Creek from 1949 through 1984, resulting from blowdown in the riparian zone.

but by 1952 the stream had cut through the remnant channel and formed two channels, each heavily influenced by LWD. The same overall morphology was retained through 1984. Similar long-term effects were evident elsewhere in Old Tom Creek and in Twelve-Mile Creek where an accumulation of 10+ pieces formed before 1956 and has remained stable through 1984 (fig. 4).

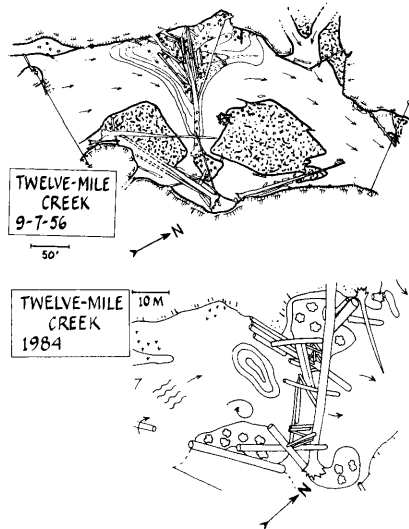

Figure 4.--Comparison of the same debris accumulation (10+ pieces) in Twelve-Mile Creek in 1956 and 1984.

Similar changes in the morphology of the Harris River Channel were caused by large woody debris present before logging (fig. 5). Changes in the stream channel from 1949 to 1956 resulted from blowdown and bank erosion, as reflected in the number of rootwads attached to trees. By 1984, large woody debris in the study section was predominantly cut logs, cut rootwads, and snags. An accumulation of more than 10 logs was lodged in the middle of the channel and was well embedded in the gravel, stabilized by the large number and size of the pieces in the accumulation. What had been the main channel in 1949 has evolved into a backwater and overflow channel in 1984. The north bank is eroding, and although the debris accumulation is stable, the stream channel is not.

#### Salmonid Populations

Coho salmon was the most abundant species caught in all streams followed by Dolly Varden (*Salvelinus malma*) and steelhead trout (*Salmo gairdneri*). Steelhead trout were common in Harris River, Indian Creek, and Maybeso Creek.

No differences in densities of juvenile coho salmon appeared among the three categories of debris accumulations (table 2). Where debris was absent, densities of coho salmon were consistently lower. Backwaters and side channels associated with accumulations of large woody debris had higher densities of juvenile coho salmon than did many of the main channel areas with debris.

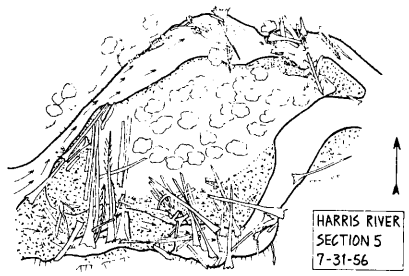
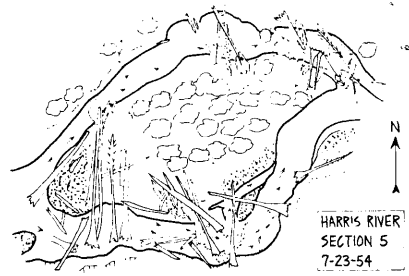
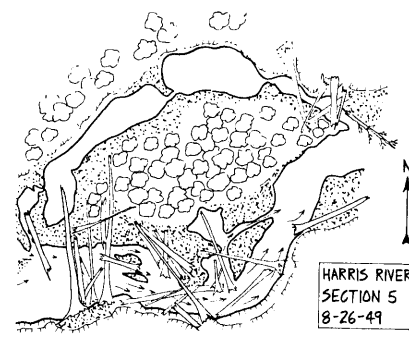

Figure 5, a-d.--Evolution of Harris River channel morphology from 1949 to 1956 (before logging) through 1984 (following logging).

The density of coho salmon fry was less than that of the age 1+ coho salmon in habitat with large woody debris accumulations of 10 or more pieces. The density of fry appeared to decrease as the size of the accumulation increased. The relatively higher density of coho fry in habitat with no debris and in the smaller pools created by single pieces probably reflects transient populations that have not established territories in better habitat.

The densities of both age groups of coho salmon varied widely among large woody debris categories. Some of the variation may have been related to the



location of the debris accumulation. Most mid channel debris accumulations, regardless of size, supported lower densities of coho than did accumulations with large rootwads that occurred along the bank. For example, the densities of fry and age 1+ coho in the mid channel accumulation shown in Figure 5d were 0.15 and 0.07 fish/m<sup>2</sup>, respectively, whereas the densities in the adjacent side channel (entering at the lower left of fig. 5d) were 1.29 and 0.32 fish/m<sup>2</sup>, respectively.

Table 2. Coho salmon density (number/meter) by size debris accumulation and in off-channel areas for all streams combined.

Habitat category	Number of reaches	Fry (Age 0) x (range)	Age 1+ x (range)
-----Number per m <sup>2</sup> -----			
Debris Accumulation			
0 pieces	3	0.26 (0-0.79)	0.09 (0-0.10)
1-4 pieces	5	0.82 (0-2.56)	0.60 (.15-1.10)
5-10 pieces	5	0.66 (0-1.51)	0.57 (.18-1.02)
10+ pieces	5	0.26 (0-.63)	0.65 (.07-1.41)
Off-channel habitat			
Backwater	3	1.01 (0-3.02)	1.00 (.29-1.83)
Side Channels	1	1.29	0.32

<sup>1/</sup> 1954 counts, later counts not available until 1984.

## DISCUSSION

The conditions in Harris River and Maybeso Creek reflect logging methods that are no longer practiced on National Forest land in Alaska (U.S. Department of Agriculture 1983). Forest management practices in Alaska presently require that trees be felled away from streams and that material entering the streams be removed within 48 hours (U.S. Department of Agriculture 1977). In Harris River and Maybeso Creek, material introduced by logging was the major component in most of the accumulations observed in 1984. Removal of streamside timber eliminated the source of new material for the streams. Logging practices that prevent large woody debris from entering streams will eliminate or reduce the source of this material in the future; riparian zones must therefore be managed for recruitment of large debris to streams.

Although logging debris can provide habitat for juvenile coho salmon, it is generally less effective than material entering a stream from natural causes. When large woody debris enters streams from natural causes, it is associated with the bank and frequently includes the rootwad. As a result it is more stable than either a cut log or a cut rootwad. Large woody debris mid channel is subject to higher water velocities, even during low flow periods, than is large woody debris along the bank. High water velocities decrease the utility of large woody debris as habitat for juvenile salmonids by decreasing the stability of both the channel and the accumulation of LWD.

The interaction between the streambank and large woody debris creates rearing habitat by forming backwaters and side channels. These areas are in many respects similar to the small tributaries that commonly provide productive habitat for juvenile coho salmon. Off-channel sections of the study streams were complex, with varying amounts of woody debris ranging in size from branches and large stems to whole trees. Few juvenile salmonids were captured in mid channel habitat--either with or without debris--in the main stream reaches. Habitat along the edges consistently supported higher densities of juvenile coho salmon than did mid channel habitat. Populations along the edges were found primarily in the habitat created by LWD.

Changes in the amount of large woody debris in the five study streams from 1949 to 1984 were related to changes in streamside vegetation, with the possible exception of Indian Creek. Both Harris River and Maybeso Creek are losing LWD. Although accumulations of large woody debris in 1984 appear to be relatively stable, new material is not entering the accumulations. The accumulations in Old Tom Creek are continually being renewed. In Twelve-Mile Creek, accumulations are relatively stable, but are less active than those in Old Tom Creek. Indian Creek contains small amounts of large material even though its riparian zone is old-growth forest. High peak discharges control the channel morphology of Indian Creek and debris is rapidly routed out of the channel. As a result, the channel is predominantly bedrock.

As large woody debris deteriorates in the streams with logged riparian zones (Harris River and Maybeso Creek), the off-channel areas, edge habitat, and backwaters will gradually disappear, because the source of new material has been eliminated. With the loss of these habitat types, the number of coho salmon in these streams is likely to decline.

## LITERATURE CITED

- Bilby, R. E. 1984. Removal of woody debris may affect stream channel stability. *Journal of Forestry*. 82(10):609-613.
- Bisson, P. A., and J. R. Sedell, (in press). Salmonid populations in western Washington streams flowing through old-growth forests and

- recent clearcuts. In Proceedings of a symposium on fish and wildlife relationships in old-growth forests. [April 12-14, 1982] American Institute of Fishery Research Biologists. Juneau, Alaska.
- Bryant, M. D. 1980. Evolution of large, organic debris after timber harvest: Maybeso Creek, 1949 to 1978. USDA Forest Service General Technical Report PNW-101. 30 p. Pacific Northwest Forest and Range Experiment Station, Portland, Oreg.
- Bryant, M. D. 1981. Organic debris in salmonid habitat in southeast Alaska: measurement and effects. p. 239-265 In N.B. Armantrout [ed] Acquisition and Utilization of Aquatic Habitat Inventory Information: Proceedings of a symposium. [October 28-30, 1981] Western Division American Fisheries Society, Portland, Oreg.
- Bustard, D. R., and D. W. Narver. 1975. Aspects of the winter ecology of juvenile coho salmon (*Oncorhynchus kisutch*) and steelhead trout (*Salmo gairdneri*). Journal of the Fisheries Research Board of Canada 32:677-680.
- Dolloff, C. A. 1983. The relationship of wood debris to juvenile salmonid production and microhabitat selection in small southeast Alaska streams. Ph.D. thesis Montana State Univ. Bozeman. 100 p.
- Elliott, S. T. and D. Hubartt. 1978. Study of land use activities and their relationship to sport fish resources in Alaska: Ecology of rearing fish. Annual performance rep. Vol. 19. Study D-I-B p. 39-52. Alaska Department of Fish and Game, Juneau.
- Heede, B. H. 1972. Flow and channel characteristics of two high mountain streams. USDA Forest Service Research Paper RM-96. 12 p. Rocky Mountain Forest and Range Experiment Station Fort Collins, Colo.
- Keller, E. A., and F. J. Swanson. 1979. Effects of large organic material on channel form and fluvial processes. Earth Surface Processes 4:361-380.
- Moore, M. K. 1977. Factors contributing to blowdown in streamside leave strips on Vancouver Island. Land management Report 3. 34 p. Victoria, B.C.: Ministry of Forests.
- Ricker, W. E. 1975. Computation and interpretation of biological statistics of fish populations. Bulletin of the Fisheries Research Board of Canada. Bulletin 191. 382 p. Ottawa, Ont.
- Sedell, J.R., and K. J. Luchessa. 1981. Using the historical record as an aid to salmonid enhancement. P 210-223. In N. B. Armantrout [ed.] Acquisition and Utilization of Aquatic Habitat Inventory Information: Proceedings of a Symposium. [October 28-30, 1981] Western Division American Fisheries Society. Portland, Oreg.
- Swanson, F. J., M.D. Bryant, G. W. Lienkaemper, and J. R. Sedell. 1984. Organic debris in small streams, Prince of Wales Island, southeast Alaska. USDA Forest Service General Technical Report PNW-166. 12 p. Pacific Northwest Forest and Range Experiment Station, Portland, Oreg.
- Swanson, F. J., G. W. Lienkaemper, and J. R. Sedell. 1976. History, physical effects, and management implications of large organic debris in western Oregon streams. USDA Forest Service General Technical Report PNW-6, 15 p. Pacific Northwest Forest and Range Experiment Station, Portland, Oreg.
- Toews, D. A., and M. K. Moore. 1982. The effects of streamside logging on large organic debris in Carnation Creek. Department of Fisheries and Oceans, Land Management Report 11 29 p. Vancouver, B. C.
- U.S. Department of Agriculture. 1977. Southeast Alaska area guide. 280 p. USDA Forest Service, Alaska Region, Juneau [unnumbered publication].
- U.S. Department of Agriculture. 1983. Final environmental impact statement for the Alaska Regional Guide. USDA Forest Service, Alaska Region Report 126 p. 75. Juneau.

# A Method for Assessing the Value of Stream Corridors to Fish and Wildlife Resources<sup>1</sup>

John C. Garcia<sup>2</sup>

---

Abstract.—SCIES provides a method for fish and wildlife managers to measure the habitat value of stream corridors, quantifying in explicit terms many complex values and factors. It was developed to have broad applications, to be flexible, to be capable of incorporating existing methods and knowledge, and to be comprehensive, easy to use, and verifiable.

---

## INTRODUCTION

The fact that this symposium has been convened shows the need for specialized management of streams and stream corridors for fish and wildlife. Proper management must begin with a systematic inventory to identify riparian and stream resource values. To be successful, the inventory should make use of all available information on fish and wildlife requirements and habitat values, and the assessment usually must be rapid. The method should apply over a wide range of ecological conditions and for a variety of kinds of information. The result of such inventories should allow managers to identify areas with potential for restoration and high-value areas needing special protection.

In response to these needs, the U.S. Fish and Wildlife Service contracted with BioSystems Analysis, Inc., to develop procedures to identify actual and potential value of stream corridors to fish and wildlife. That procedure is called SCIES, Stream Corridor Inventory and Evaluation System. A complete exposition of SCIES is found in Garcia et al. (1984).

## KEY FEATURES OF SCIES

Special features of SCIES are the following. First, SCIES provides both a comprehensive list of factors thought to be important to fish and wildlife in stream corridors and a set of scoring curves which translate measurements of biological and physical factors into scores.

Second, SCIES is flexible in allowing the user to choose the factors to be scored and to determine which stream corridor characteristics to emphasize in the evaluation.

Third, SCIES maximizes the use of existing biological and physical data and evaluation systems. It accepts both direct population measures and indirect habitat parameters as evidence of stream corridor values, and readily incorporates the methods and results of other classification and evaluations systems, such as IFIM and HEP.

Fourth, all value scores, relative weights assigned to each parameter, and methods of calculation must be specified and recorded when completing an evaluation. SCIES recording procedures make all value judgements explicit.

## HOW SCIES WORKS

In essence, SCIES identifies areas of high value by scoring important stream corridor characteristics (e.g., instream flow or density of snags in the corridor) on a scale of zero to 100. For some adverse land and water uses, a scale of zero to -100 is used. High value stream corridors are those scoring near 100.

Figure 1 illustrates the conceptual approach to SCIES valuation. Stream corridor characteristics which contribute to the final fish and wildlife scores are arranged in a hierarchy with three levels. Lowest-level measures of physical and biological attributes are converted to scores. The scores from several attributes are combined, following simple arithmetic rules, to produce second-level scores. A series of second-level scores is then combined to produce third-level scores, one for each major component of stream corridor value.

The procedure provides scores for four separate third-level components: fish, wildlife, species of concern, and human use of land and water resources in the corridor. These four components are called factors. The second-level characteristics which comprise a factor are called criteria. For example, the wildlife factor includes criteria such as species abundance, species diversity, terrestrial habitat characters, aquatic habitat characters, adjacent communities, and adjunct evaluations. There can be two or more levels of

---

<sup>1</sup>Paper presented at the North American Riparian Conference. (University of Arizona, Tucson, April 16-18, 1985).

<sup>2</sup>John C. Garcia is a principal of BioSystems Analysis, Inc., Sausalito, Calif.

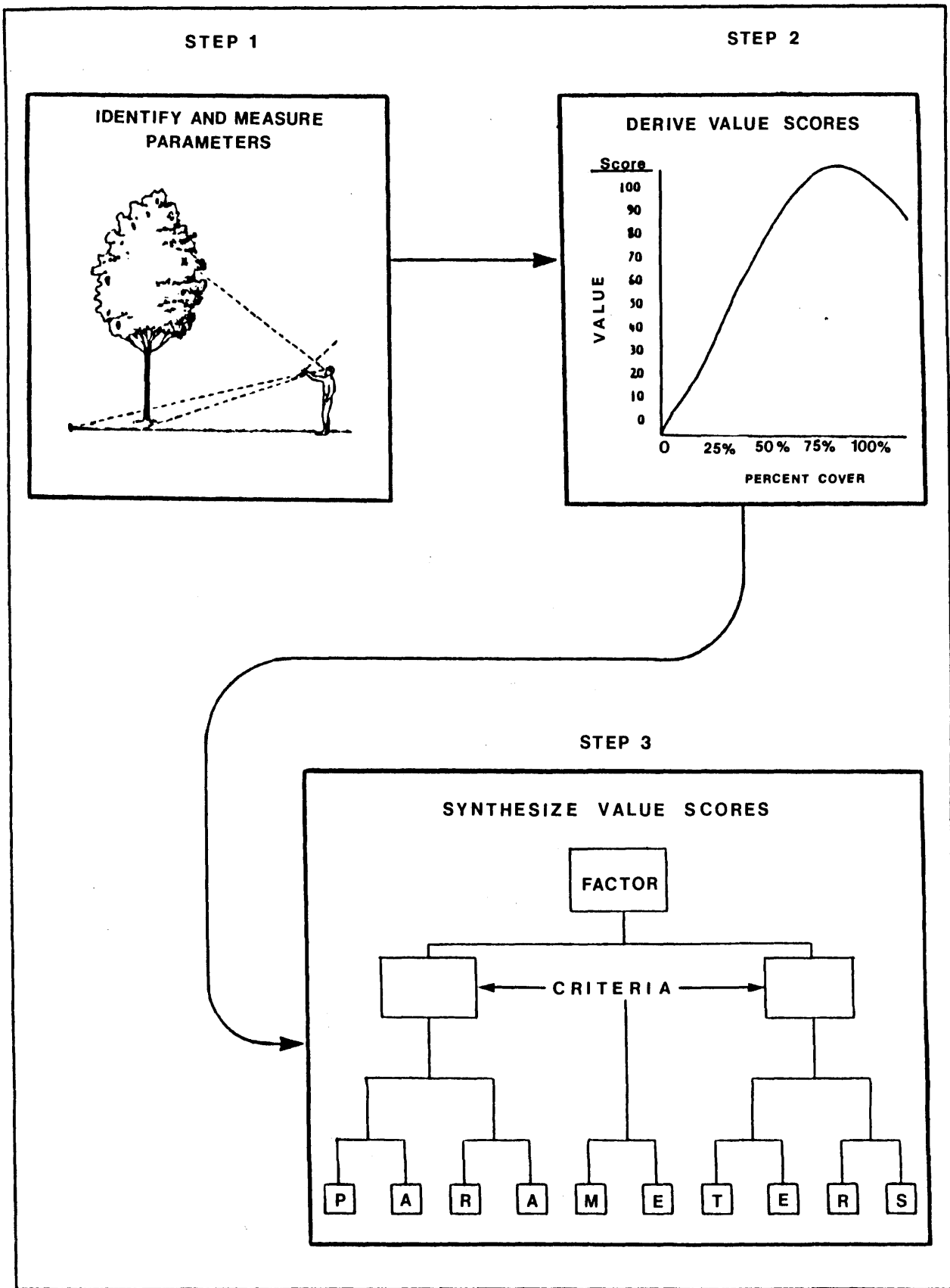

Figure 1.--Conceptual approach to SCIES valuation.

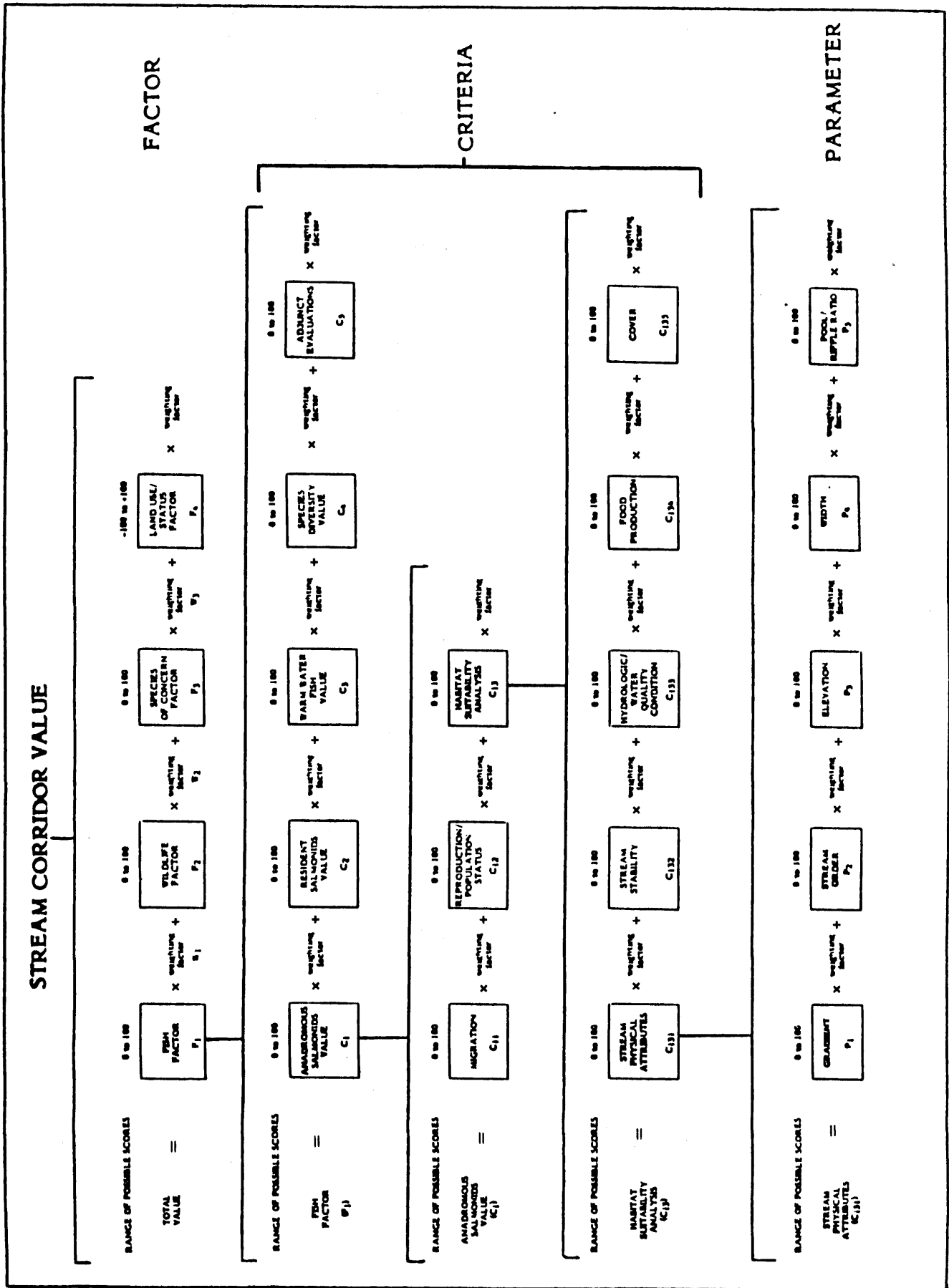

Figure 2.--Diagrammatic illustration of SCIES process for synthesizing value scores.

criteria, with higher levels incorporating information from lower levels. E.g., terrestrial habitat can be subdivided into herbaceous species, shrub species, shrub stratification, tree species, tree stratification, snags, talus, and vertical cliff subcriteria. The user can add or substitute others.

Value scores for criteria are derived from measurement of biological and physical attributes. Each such measurable attribute is termed a parameter. The value score for a criterion is determined by combining the scores of its component parameters. As an example, Figure 2 shows how the fish factor is segregated into some of its constituent criteria and parameters.

#### DETAILS OF THE PROCEDURE

Each application of SCIES begins with selection of a group of parameters thought to be important to fish and wildlife in the stream corridor under investigation. These parameters are the measurements familiar to field workers. They include indices of population abundance and characteristics of stream corridors that affect abundance. E.g., hydraulic and water quality conditions, a criterion of the fish factor, include temperature, depth, velocity, substrate, dissolved oxygen, pH, and turbidity.

Because different parameters may be important in different places or under different conditions, SCIES allows flexibility in choosing parameters to be used in a given evaluation. A preliminary list of parameters, criteria, and factors is provided in Garcia et al. (1984). This list is not exhaustive, but is comprehensive and includes what we consider to be the more important parameters.

Often the choice of parameters is restricted by the availability of field measurements. SCIES allows full use of existing data, so long as the same kinds of measurements have been taken in each stream corridor of interest.

Once the parameters are measured, either through field work, aerial reconnaissance, or taken from previous studies, they are translated to dimensionless value scores. The translation is accomplished through use of evaluation curves, histograms, equations, and matrices to equate scores from zero to 100 with the possible range of measurements of each parameter. For example, for salmonid fishes a stream water temperature of 20 C may have a value of 50, and at some higher temperature, say, 25 C, stream value would drop to zero.

Garcia et al. (1984) provide preliminary scoring curves for the parameters contained in SCIES. The curves were developed for Pacific Northwest conditions, and users should construct, or at least review, the curves for each new area in which SCIES is applied.

The scores of various parameters may not reflect the full picture for management. For various reasons certain parameters—such as the existence of migratory barriers for anadromous salmonids or the preservation of habitat elements needed by an endangered

species—may receive more management attention or may be more important in a particular biogeographic region. SCIES allows important stream corridor characteristics to be emphasized during evaluation. This is accomplished by using variable weighting factors, which are coefficients that multiply base value scores. The sum of all weighting factors at any level of analysis must equal 1.0. This rule insures that the total score will always be a number between zero and 100 (or -100) at every level.

Just as parameter scores are weighted and then summed to produce criterion scores, criterion scores are weighted and combined to obtain factor scores. Although factor scores may be combined to express the overall value of a stream corridor, it is probably more useful to keep them separate.

As with value scores, weighting factors associated with each parameter, criterion, and factor must be specified and recorded during the evaluation.

#### APPLICATIONS

The two chief uses of SCIES are (1) to compare the value to fish and wildlife of different stream corridors and (2) to focus the evaluation on specific issues and species, where it is desirable to do so.

Scoring may be calibrated to compare various reaches against the best reach in the stream, the watershed, or the region. The user can model stream corridor impacts by plugging in parameter values expected after an impact occurs. Several runs of SCIES may be made, changing parameter scores or weighting factors to reflect options in management, and resultant values compared. The user can focus the evaluation by appropriate choice of parameters, criteria and weighting factors.

By applying weighting factors to the scores, SCIES makes room for value judgement and makes such judgement explicit at each level of analysis. Researchers seeking to compare the results of independent studies thereby have a firm basis for understanding how human values have influenced the results, and for standardizing results according to their own scale of weighting factors. Professional and public reviewers similarly have a solid basis for understanding and responding to SCIES results.

#### LITERATURE CITED

Garcia, J., J. Pratt, G. Ahlborn, S. Orloff, K. Richter, J. Dragavon, J. Eby. 1984. A method for assessing the value of stream corridors to fish and wildlife resources. Vol. I, methods and applications. Vol II, parameter selection and scoring. BioSystems Analysis, Inc., Sausalito, Calif..

# Amphibians and Reptiles in Southwest Riparian Ecosystems<sup>1,2</sup>

Charles H. Lowe<sup>3</sup>

---

Abstract.--Obligate riparian amphibians and reptiles in Arizona and Sonora, Mexico are discussed. Local population extinctions in Arizona are examined. Special status for obligate riparian species is proposed.

---

Among the obligate riparian species that occur both in southern Arizona and adjacent Sonora, Mexico there are two native turtles and four native snakes; these riparian reptiles also have limited distributions in adjacent southern New Mexico. All but one have wider distributions in the Republic of Mexico than in the United States.

## Obligate Riparian Species

<u>Kinosternon flavescens</u>	Yellow Mud Turtle
<u>Kinosternon sonoriense</u>	Sonoran Mud Turtle
<u>Thamnophis eques</u>	Mexican Garter Snake
<u>Thamnophis cyrtopsis</u>	Black-necked Garter Snake
<u>Thamnophis marcianus</u>	Checkered Garter Snake
<u>Thamnophis rufipunctatus</u>	Narrow-headed Garter Snake

In spite of what may appear to be wide geographic distributions, these species are riparian obligates that have narrowly limited ecological distributions and low total species-population densities, however dense may be some of the local populations that remain. While strictly speaking they are not yet endangered as species, all are clearly threatened species throughout their southwestern distributions. Perhaps oddly, the two turtles have more robust populations in Arizona than do the riparian snakes. Only one of four snakes (T. cyrtopsis) is dependably found when searched for in its old known localities and habitats in Arizona. While it remains among those obligate species somewhat less affected by riparian alterations in the Southwest, during the 1980's it is also on the brink of elimination from some riparian communities in Arizona where it is now seriously reduced in population size.

Local extinctions (extirpations) of populations of obligate riparian reptile species has been in progress in Arizona for about 20 years but are essentially unrecorded. One of these extinctions is shown in Figs. 1 and 2 for T. marcianus on the former Santa Cruz River at Tucson, Arizona. The data are for a once robust population located on the western floodplain of the river between Grant Road and Sweetwater Drive. The density graphed is mean density per five-year period for transect observations on the floodplain using Silverbell Road. The last permanent water in the Santa Cruz River at Tucson was in 1941. The last checkered garter snake was seen in the population in 1976. The survivorship curve in Fig. 2 is an extinction curve for this population. The final cause of extinction was encroachment--agricultural followed by urbanization.

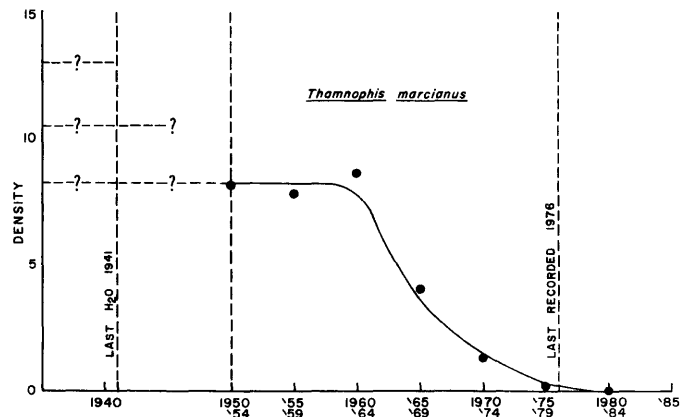

Fig. 1.--Thamnophis marcianus on the floodplain of the Santa Cruz River, northwest Tucson, Arizona. Local population extinction due to man-made encroachment.

<sup>1</sup>Paper presented at the first North American Riparian Conference, Tucson, Arizona, April 16-18, 1985.

<sup>2</sup>For discussions on amphibians and reptiles in Southwest riparian ecosystems I thank William A. Calder, Stephen F. Hale, Terry B. Johnson, Cecil R. Schwalbe, and William H. Woodin.

<sup>3</sup>Department of Ecology and Evolutionary Biology, University of Arizona, Tucson, Arizona, 85721.

Native animal species that are obligate riparian species are usually the first to disappear from the riparian community as the result of significant alterations to the environment. Important man-made perturbations causing riparian habitat alteration and destruction in the Southwest are given in Table 1. Documented cases of local population extinctions of obligate riparian reptiles (3) and amphibians (1) in Arizona are given in Table 2.

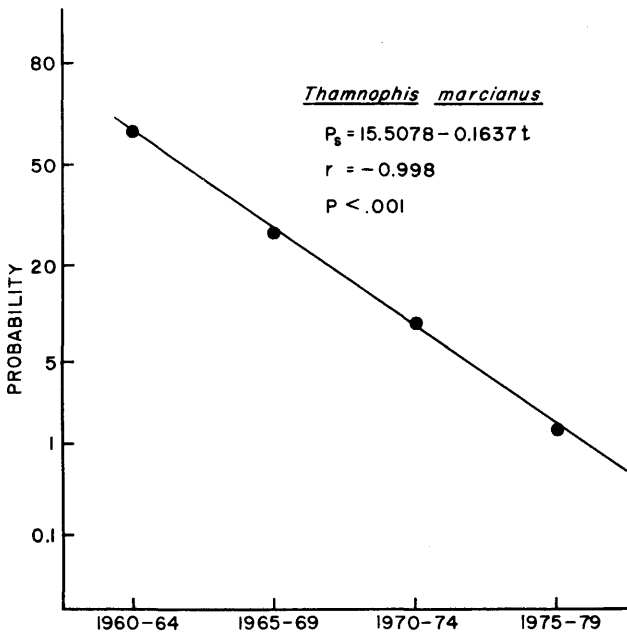

Fig. 2.--Probability on time for survivorship of Thamnophis marcianus, after 1960 to extinction; see Fig. 1.

These extirpation events took place in the 1960's and 1970's. The local extinction of riparian amphibian and reptilian populations in Arizona is clearly in process having been underway for a time equal to about one human generation. This is not unexpected. Arizona is participating in the current man-made global faunal mass extinction that was accelerated earlier during this century.

#### AMPHIBIANS

Our vertebrate amphibian fauna is far more diverse than many suspect. There are 24 species in Arizona and 31 in Sonora. Most of the amphibians in Arizona-Sonora are anurans (frogs and toads);

Table 1.--Man-made perturbations causing riparian habitat alterations and destruction in the North American Southwest, United States and Mexico.

- 
- Pump Down, Damming
  - Encroachment
    - Agricultural Reclamation
    - Urbanization
    - et al.
  - Pollution
    - Acid Rain
    - Pesticides
    - Trace Metals
    - et al.
  - Grazing, Woodcutting
  - Exotic Species
- 

three are salamanders. All are riparian species and all but two are obligately so, for they must use surface water--permanent or temporary, running or standing--for reproduction. While we assume that all of these species may not be equally threatened in 1985, all are riparian species and thus are clearly threatened as we near the close of the century. They are threatened principally by encroachment, pump down, and by pollution including acid rain and pesticides.

On what basis should we finally judge the threatened status of Arizona's amphibian species? It is self-evident that the ranid frog (genus Rana) populations in Arizona are threatened and 3 species are properly so listed (AGFD 1982). There is (was) a total of 5 native Rana species in Arizona, and in the longer run to the end of the century and

Table 2.--Local extinctions of obligate riparian populations of amphibians and reptiles due to man-made alteration and destruction of riparian habitats in Arizona.

Species	Locality	Population Status	Decade	Riparian Alteration	Riparian Type
<u>Thamnophis eques</u>	Rillito floodplain vicinity Tucson	Extinction	1960	Encroachment Urbanization	xeroriparian
<u>Thamnophis marcianus</u>	Santa Cruz floodplain vicinity Tucson	Extinction	1970	Encroachment Urbanization	xeroriparian
<u>Thamnophis rufipunctatus</u>	Fort Valley vicinity Flagstaff	Extinction	1960	Pump Down	hydroriparian
<u>Rana tarahumarae</u> <sup>1</sup>	Santa Cruz County (6)	Extinction	1970	Pollution	mesoriparian

<sup>1</sup> Species apparently eliminated from the fauna of Arizona; work in progress (S. F. Hale).



beyond they all are unquestionably in subequal jeopardy with Rana tarahumarae the Madrean Tarahumara Frog which already may be completely eliminated from Arizona's fauna by habitat pollution (Hale and May 1983).

What is the time frame that we have in mind? What is our time perspective for threatened and endangered species? Is it this decade (?), next decade (?), or the next century that is now less than one human generation away? In talking to variously concerned people interested in the subject of threatened and endangered species in the Southwest, both in Mexico and the United States, I find that their time perspective on the subject is often hazy or even unconsidered.

It is, of course, much later than we think. For example, in Arizona during 1970-1980 the Tarahumara Frog was eliminated from 5 of the 6, or 6 of the 6, of its historically known populations (see Hale and May 1983). Most or all of the other Rana species in Arizona, all four of which are

tara frogs to succumb first, and the semiaquatic pip frogs (that are periodically terrestrial) to be eliminated at some intermediate time point. We will, of course, have to wait and see. It should not be a long wait, particularly if the price for Arizona copper goes up substantially and/or the Nacozari smelter goes into operation on schedule.

Whatever the lethal mechanism and wherever it is mediated--in the water, soil, food, shelter, all or other--the obligate riparian species we have left are threatened now (Table 1). In general, species are "threatened" in the "now" and "endangered" in the "future;" they are finally doomed however when the time perspective is inadequate in the now.

#### RECOMMENDATIONS

With regard to Arizona's riparian species, several recommendations are made at this time for the current listing of Threatened Native Wildlife in Arizona (AGFD); see Table 3. The listing of

Table 3.--Specific recommendations on obligate riparian species of amphibians and reptiles for Threatened Native Wildlife in Arizona by the Arizona Game and Fish Commission (see AGFD 1982).

AMPHIBIANS, Obligate Riparian	Sources of Alteration and Destruction
Retain: All 7 species listed	
Add: <u>Rana chiricahuensis</u>	Encroachment, Pollution
<u>Rana yavapaiensis</u>	Pump Down, Encroachment, Pollution
TURTLES, Obligate Riparian	
Retain: <u>Kinosternon flavescens</u>	Encroachment, Pollution
Add: <u>Kinosternon sonoriense</u>	Encroachment, Pollution, Pump Down
SNAKES, Obligate Riparian	
Retain: <u>Thamnophis eques</u>	Encroachment, Grazing
<u>Thamnophis rufipunctatus</u>	Encroachment, Pump Down
Add: <u>Thamnophis cyrtopsis</u>	Encroachment, Grazing
<u>Thamnophis marcianus</u>	Encroachment, Pump Down

"pips" in the Rana pipiens complex of leopard frogs, are surely to follow the "taras" if, indeed, pollution related to acid rain and/or trace metals is substantiated beyond reasonable doubt as a causal factor in the extirpation of R. tarahumarae.

The case is particularly instructive. In freshwater populations where the taras have been eliminated (e.g., Sycamore Canyon, Santa Cruz Co., Arizona), the sympatric pips remain as do the native fish. If lethal pollutant toxin(s) is mediated partly or wholly through the stream water, we could be observing the beginning of a riparian community physiological extinction pattern in which the aquatic-semiaquatic species with the highest physiological flushing rate is eliminated first; fluid flushing processes are but one of the possible skin-related avenues for toxic poisoning in frogs. Because fishes are integumentally waterproofed (with lower urine flows and lower glomerular filtration rates), while frogs are integumentally highly permeable to water (with higher urine flows and higher glomerular filtration rates), the fishes would be expected to succumb last, the highly aquatic

still additional threatened riparian species is appropriate and soon should be considered further.

Regarding the field (status) investigations of Special Status Species, they should include for each known population and locality (i) the current age-specific population density, and (ii) an historic resume on presence, density, habitat condition, and man-made perturbations affecting habitat alteration and quality at least since the turn of the half century.

#### LITERATURE CITED

- Arizona Game and Fish Department. 1982. Threatened native wildlife in Arizona. Arizona Game and Fish Commission, Phoenix, Arizona.
- Hale, S. F. and C. J. May. 1983. Status report for Rana tarahumarae Boulenger. Report from Arizona Natural Heritage Program, Tucson, to U. S. Fish and Wildlife Service, Albuquerque, New Mexico.

# Microhabitats of Lizards in a Southwestern Riparian Community<sup>1</sup>

K. Bruce Jones<sup>2</sup> and Patricia Conley Glinski<sup>3</sup>

---

Abstract.--Relationships between lizard abundance and distribution, and certain selected microhabitats were determined for a southwestern riparian community. Distribution of lizards in riparian habitat appear to reflect availability of preferred habitats; certain lizards and microhabitats were widespread while others were limited to small portions of the study area. Patterns of lizard distribution in microhabitats are discussed.

---

## INTRODUCTION

Concern over large-scale loss of riparian habitat throughout the West has led to numerous recent studies on relationships between wildlife and these vegetation communities. Although many studies have documented relationships between riparian habitat structure and birds (Stevens et al. 1977, to name one), little data are available on similar relationships in lizards. Literature available on lizard microhabitats in riparian communities are generally limited to a few selected species. For example, Vitt et al. (1981) determined differences in microhabitat among 3 arboreal lizards (Sceloporus magister, Urosaurus ornatus, and Urosaurus graciosus) in a mesquite woodland. Although these studies provide information on selected lizard species, they do not assess habitat partitioning among an entire riparian lizard community.

We studied a lizard community along the Hassayampa River near Wickenburg, Arizona primarily to determine associations between lizards and riparian microhabitats.

## THE STUDY AREA

The Hassayampa River south of Wickenburg, Arizona provided an outstanding opportunity to study a lizard community along a relatively unaltered desert stream (no major water impoundments upstream). The study site consisted of a 1.9 hectare plot (60 x 315 m) in a mature

cottonwood-willow community approximately 10 km southeast of Wickenburg on the west side of the river (elevation ca. 585 m). The study site was on private land which is primarily managed as a resort and bird sanctuary. Other than a small number of cows grazed during winter months, there was little disturbance on the site.

Overstory on the study area consisted of cottonwood (Populus fremontii), willow (Salix gooddingii), mesquite (Prosopis velutina), and salt cedar (Tamarix sp.). Seep willow (Baccharis salicifolia) made up the entire shrub understory, and bermuda grass (Cynodon dactylon) was the only perennial grass. Tree species were unevenly dispersed throughout the study area; cottonwoods and willows were near water or in areas where the stream bed was formerly located, and mesquite was on elevated sections dominated by sand (fig. 1).

The study area was approximately 1 m above the stream bottom, with three small drainages transecting approximately 1/2 the width of the grid (fig. 1). Periodic flooding in these drainages (observed 4 times during the study) caused accumulation of debris (logs, limbs, leaves, and occasionally tires) at the base of trees, especially multibranched willows and cottonwoods (hereafter referred to as debris heaps, fig 2). Debris heap size varied, with some piles as large as 1.8 m high and 6 m wide. Although debris heaps are formed by flooding, the top of these structures do not represent the high water line during flooding; debris heap height is achieved by addition of flood debris at the base which forces formerly deposited material up along the tree.

Substrate on the study area was mostly sand, although there were areas with limited amounts of rock (10-30 cm dia). Rocky areas were mostly limited to the three small drainages previously described (fig. 1), and the river bed. Downed logs, limbs, and leaf litter were abundant throughout most of the study area, except in areas

---

<sup>1</sup> Paper presented at the North American Riparian Conference, April 16-18, 1985, Tucson, Arizona.

<sup>2</sup> Wildlife Biologist, U.S. Bureau of Land Management, Phoenix, Arizona 85068

<sup>3</sup> Wildlife Manager, Arizona Game and Fish Department, Wickenburg, Arizona 85358

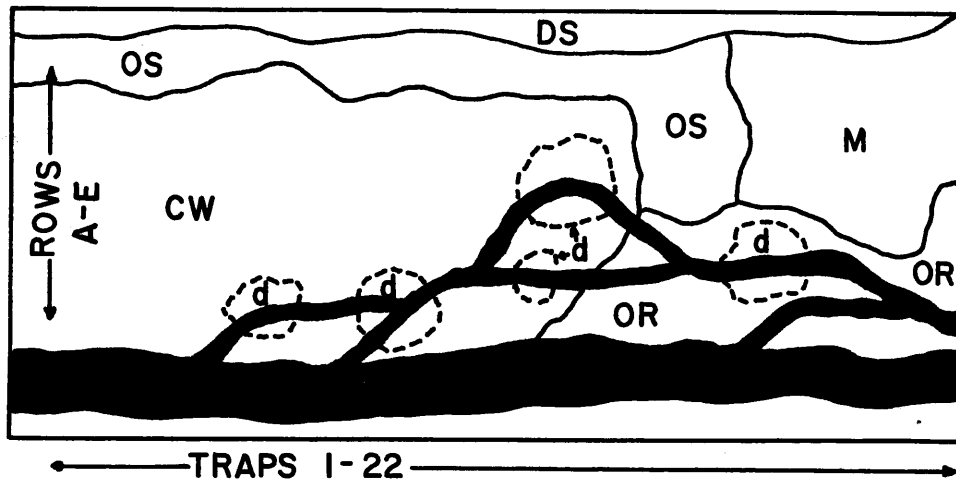

Figure 1.--Distribution of habitats in the study area. CW = cottonwood-willow stand, OS = open canopy/sand substrate, OR = open canopy/rock substrate, M = mesquite stand, DS = desert shrub, and d = debris heap. Dark areas are the river and small drainages.

dominated by mesquite (fig. 1). Some leaf litter patches under trees and shrubs were as deep as 10 cm.

#### METHODS

Lizard occurrence and abundance was determined by a pit-fall trapping system consisting of 110, double-deep 3 lb coffee cans placed 15 m apart in a 22 x 5 grid trapping configuration (1.9 ha, fig. 1). Covers were placed approximately 15 cm over the top of each trap to reduce loss of animals due to desiccation. Each cover was given a letter representing a row (A-E) and a number (1-22) for identification (fig. 1). Traps were continuously

open between 3 March and 30 October 1984, and checked every three days. Lizards captured in traps were measured (snout-vent), weighed, sexed, toe-clipped for individual identification, and released into potential cover approximately 2 m from the capture site. Pit-fall trapping was used because it effectively traps most lizards, including skinks which are inadequately sampled by line transects.

While traveling between pit-fall traps, we recorded observations of lizards on certain microhabitats (listed in table 1). These observations included lizard age class, time of day and date, the type of microhabitat, location on the grid (nearest trap), and weather.

Microhabitat data were collected at each trap by a point-center quarter method (Muller-Dombois and Ellenberg 1974); each trap was used as the center point for the procedure. This procedure determines spatial arrangement of microhabitats around each trap as a function of distance (total 110 points, 440 quarters or samples). In addition, physical sizes of each microhabitat were determined. Table 1 provides a list of microhabitats and measurements taken around each trap.

Table 1.--List of habitat components (microhabitats) measured around each trap. Frequency = number of quarters with a certain component

Soil Type (at trap) <sup>1</sup>	Rock Width
Vertical Cover (over trap) <sup>1</sup>	Rock Frequency
Distance to leaf litter patch <sup>1</sup>	Distance to Tree <sup>1</sup>
Leaf Litter Depth	Tree Height
Leaf Litter Frequency	Tree Width (Crown)
Distance to Log <sup>1</sup>	Tree Frequency by species
Log Diameter	Distance to Shrub <sup>1</sup>
Log Frequency	Shrub Height
Distance to Debris Heap <sup>1</sup>	Shrub Width (Crown)
Debris Heap Width	Shrub Frequency
Debris Heap Depth	Distance to Grass Patch <sup>1</sup>
Debris Heap Frequency	Grass Height
Distance to Rock <sup>1</sup>	Grass Frequency

<sup>1</sup> Microhabitats also recorded for lizard observations



Figure 2.--Example of a debris heap (2 m deep x 3 m wide).

Individual lizard species abundance (total number of different individuals of each species) was compared to microhabitat data at each trap and submitted to a Step-wise Multiple Regression analysis to determine significant relationships between lizards and microhabitat. In addition, habitat data were submitted to a Principle Components Analysis, and mean factor scores for each lizard were computed to graphically compare species associations with microhabitat.

Niche breadths were determined from a Shannon-Wiener diversity index (see Vitt et al. 1981).

Species abundances at each trap were submitted to a chi-squared goodness of fit test to determine if species were randomly distributed over the sample area. In addition, daily and monthly activity patterns were determined for lizards using trapping and observation data.

### RESULTS

Seven species of lizards were trapped on the study site. The desert spiny lizard (*Sceloporus magister*) was by far the most abundant species and the greater earless lizard (*Cophosaurus texana*) the least common (table 2). Only Arizona skinks (*Eumeces gilberti arizonensis*) and greater earless lizards were limited exclusively to the riparian community; all other lizards occur in adjacent Sonoran Desert habitats (Jones unpubl. data). In addition to lizards, five species of snakes, one aquatic turtle, and three species of amphibians were trapped during the study (table 2).

Table 2.--Abundance, microhabitat use and niche breadth for 7 lizards on the study area based on observation data. Niche breadth was computed from a Shannon-Wiener diversity index from observation data. Numbers in parentheses indicate the number of individuals pit-fall trapped. Number of other reptiles and amphibians trapped are also listed.

Litter (open canopy)	Litter (under shrubs)	Open Sand	Large Logs	Rocks	Tree	Debris Heaps	Shrub	Niche Breadth
<u>Western whiptail lizards (104)</u>								
40	72	3	-	-	-	-	-	.32
<u>Arizona skinks (77)</u>								
-	-	-	-	-	-	1	-	.00
<u>Zebra-tailed lizards (52)</u>								
2	3	39	-	-	-	-	-	.19
<u>Greater earless lizards (11)</u>								
-	-	-	4	33	-	-	-	.14
<u>Side-blotched lizards (17)</u>								
-	-	1	-	13	-	-	-	.11
<u>Tree lizards (120)</u>								
-	-	-	24	3	47	17	19	.60
<u>Desert spiny lizards (182)</u>								
-	-	-	31	-	30	8	-	.43

Additional captures: Black-headed snake (6), Ground snake (1), Western blind snake (6), California kingsnake (1), Black-necked garter snake (1), Sonoran mud turtle (2), Woodhouse's and Southwestern toad hybrid (89), Colorado River toad (17), and Western spadefoot toad (7).

Chi-squared goodness of fit tests on lizard abundance reveal that only tree (*Urosaurus ornatus*) and desert spiny lizards were randomly distributed over the entire grid ( $p > .05$ ), whereas all other lizards were found in clustered, nonrandom patterns ( $p < .05$ ). Earless and side-blotched (*Uta stansburiana*) lizards were trapped only in areas dominated by cobble and gravel, whereas zebra-tailed lizards (*Callisaurus draconoides*) were trapped in areas with little canopy and sand substrate. Earless and zebra-tailed lizards were not trapped together anywhere on the grid. Direct observations of these lizards reveal similar relationships; earless and side-blotched lizards were observed almost entirely on rocks, and zebra-tailed lizards were always observed on open sand or leaf litter (table 2). Western whiptail lizards (*Cnemidophorus tigris*) were trapped or observed mostly in areas of low shrubs, leaf litter, and open canopy (table 2), while Arizona skinks were most abundant in areas with large debris heaps and leaf litter.

Based on microhabitat use (from observation data only), tree and spiny lizards had the greatest niche breadths, and earless and side-blotched lizards had the lowest (table 2). Although Arizona skinks had a niche breadth of 0, there was only one sighting of this lizard during the entire sampling period.

Daily activity patterns of lizards were very similar; peaks were generally between 1030 and 1200 h. Activity of Arizona skinks are probably earlier, but we observed only one lizard. Monthly activity patterns were relatively similar in the spring; most lizard peak activity occurred in May or June. Spiny, earless and zebra-tailed lizards had another activity peak in September and October, when primarily hatchlings and juveniles were active. Although zebra-tailed lizards are active a month earlier than earless lizards, their monthly activity patterns are almost identical. Similarly, activity patterns of skinks and whiptail lizards in the spring are nearly identical, but small late summer and fall peaks do not overlap, i.e. August in skinks and September in whiptails.

Multiple step-wise regression of lizard abundance with 29 habitat variables listed in table 1 revealed only a few significant relationships. Forty percent of the variation in abundance of Arizona skinks was explained by the depth, nearness and frequency of debris heaps and leaf litter (Multiple corr. coef. = .67,  $p < .05$ ). Side-blotched and greater earless lizards were the only other lizards with variation in abundance explained by a habitat variable; 37% of abundance in the former and 53% in the later was explained by rock frequency and nearness of rock to traps (Multiple corr. coef. = .67,  $p < .05$ ).

When mean factor scores are plotted for lizards based on reduction of 29 variables listed in table 1 into three axes via a Principle

Components Analysis, relative association of lizards with microhabitats are illustrated (fig. 3). Generally, these data support trapping and lizard observation data previously discussed.

### DISCUSSION

Our data show that lizards are partitioned in two dimensions: spatially (microhabitat use) and temporally (activity periods). A third dimension, food, probably represents a third partitioning dimension since lizards vary in size and morphology, and use different microhabitats and foraging styles (see Vitt et al. 1981). Daily and monthly activity patterns of lizards on the study area do not seem to play a major role in the partitioning of habitat space; most lizards showed little difference in activity patterns. Similar to findings of Vitt et al. (1981) and Ortega et al. (1982), microhabitat partitioning appears to be of primary importance.

The distribution of lizards on the study area appear to reflect availability of certain microhabitats, although most lizard abundance was not specifically correlated to microhabitat. Capture of lizards in transit between preferred microhabitat may account for lack of correlation between lizard abundance and certain microhabitats.

Desert spiny and tree lizards are common throughout the study site, which reflect the area's consistently abundant tree and surface log microhabitats. Widespread distribution also reflect these lizards ability to use different microhabitats as evidenced by their relatively high niche breadths. Vitt et al. (1981) showed similar relationships between these lizards and tree and surface log microhabitats. Greater niche

breadth of tree lizards in our study vs. that of Vitt et al. (1981) probably reflect greater microhabitat diversity and abundance on our study area, especially leaf litter, vegetation debris, and rocks.

Body size and foraging style may play major roles in determining association between lizards and microhabitats. Because they are relatively large, desert spiny lizards are less susceptible to rapid ambient temperature changes, whereas the smaller tree lizard's internal temperature will change more rapidly with fluctuations in environmental temperatures. Vitt et al. (1981) suggest that by remaining in the canopy of trees (and in our study shrubs), lizards are less susceptible to rapid ambient temperature change; tree and shrub canopy modify the climate immediately surrounding the lizard.

In addition to body size, other morphological adaptations may also account for microhabitat uses in riparian lizards. Zebra-tailed and earless lizards are ecologically similar; both use a "sit and wait" foraging strategy (Pianka 1966). The major difference in foraging behavior between these lizards is that zebra-tailed lizards wait for prey on sand substrate, occasionally burrowed (Belfit personal comm.), while earless lizards perch on rocks or gravel (observed in this study). Zebra-tailed lizards are morphologically adapted for movement on open sand substrates (long forelegs and hindlegs, Pianka and Parker 1972). Presumably this adaptation would also enhance burrowing, but makes use of other microhabitats, such as rock, less adaptive (see Vitt 1981 for discussion of morphological adaptations and microhabitat use). This may in part explain current allopatry of these two lizards on the grid, although competitive exclusion can not be ruled out.

Association of side-blotched and greater earless lizards with rock may reflect these lizards' foraging style. Both lizards use a "sit and wait" foraging strategy (Pianka 1966). Presumably, this type of foraging style would be enhanced by use of rock (better visibility). This advantage would be partially offset by increased predation due to exposure. The western whiptail lizard uses a "widely foraging strategy", moving along the ground and feeding in litter patches (similar to a bird) in areas near trees and shrubs where sunlight penetrates (Pianka 1970). This strategy appears to explain this lizard's association with similar microhabitats on our study area.

Although we understand how many of the behavioral and morphological adaptations make certain lizards more adaptive in specific microhabitats, it is impossible to infer contributions made by each adaptation in organizing current lizard distributions on the study area (see Vitt et al. 1981; Ortega et al. 1982). Competition may have played a major role in determining initial segregation of lizards into microhabitats during colonization of the area, but

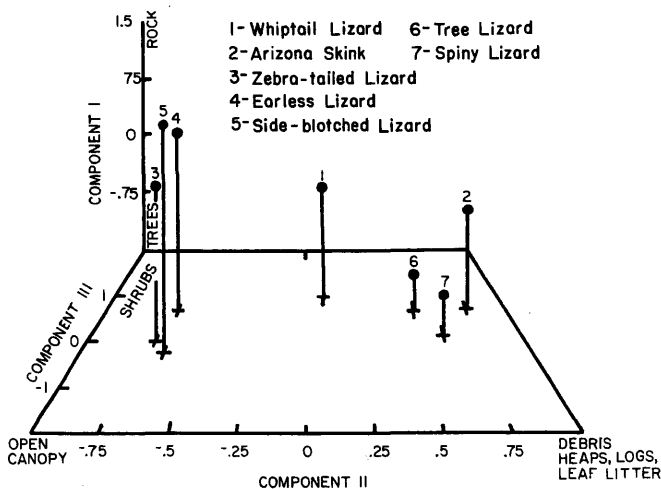

Figure 3.--Arrangement of riparian lizards along three habitat vectors (principle components).

this mechanism probably plays a minor role in maintaining current distribution of lizards in the riparian community; competition has been reduced by behavioral and morphological adaptations as previously discussed (see Vitt 1981; Vitt et al. 1981; Ortega et al. 1982; Tinkle 1982; Price et al. 1985).

The association of Arizona skinks with debris heaps and litter, and secretive behavior (only one lizard observed at large during the entire study), are consistent with data from other studies of skinks (Fitch 1955; Jones 1981; Jones et al. 1985). Although we observed only one lizard in a debris heap, skinks are known to deposit eggs and seek cover in these microhabitats (Fitch 1955, Jones unpubl. data).

The Arizona skink is known only from the Hassayampa River (Jones 1985), and this site is nearly 350 m lower than any other location for the species in Arizona (Jones et al. 1985). Most skinks occur within the Upper Sonoran Life-zone. Therefore, it appears that the Arizona skink has survived on the Hassayampa River due to moderating effects of deciduous trees, perennial water, and large debris heaps and leaf litter. The loss of these microhabitats due to alteration of the riparian community would probably extirpate this subspecies. For example, water impoundment upstream could reduce flood conditions and prevent the formation of large debris heaps. Likewise, excessive livestock grazing could dramatically reduce willows and cottonwoods which assist in formation of debris heaps. Significant losses in riparian habitat may also extirpate the earless lizard, black-headed snake (Tantilla hobartsmithii), Sonoran whipsnake (Masticophis bilineatus), ring-necked snake (Diadophis punctatus) and Sonoran mudturtle (Kinosternon sonoriense) from the area since these reptiles do not occur in adjacent Sonoran Desert habitat (Gates 1958; Jones unpubl. data).

It is interesting to note that some lizards known to inhabit adjacent Sonoran Desert do not occur in the riparian community. Most of these species, including banded geckos (Coleonyx variegatus), Gila monsters (Heloderma suspectum), and leopard lizards (Gambelia wislizeni) use rodent burrows as cover sites. In our study area, there were few rodent burrows. In fact, only pack rats (Neotoma sp.) and desert shrews (Notiosorex crawfordi) were trapped on the grid; both species use debris heaps for cover. Lack of burrowing rodents may reflect inadequate burrowing substrate (mostly sand and large rock) and a high water table, which makes our study area unsuitable to lizards that rely on rodent burrows for cover.

#### ACKNOWLEDGEMENTS

We thank Scott C. Belfit, Richard Glinski, Lauren P. Kepner, and William G. Kepner for review of this manuscript. We also thank Richard Glinski, Chuck Hunter, and John McConnaughey for helping with data collection.

#### LITERATURE CITED

- Belfit, S. C. Personal communication.
- Fitch, H. S. 1955. Habits and adaptations of the Great Plains skink. *Ecol. Monog.* 25:59-83.
- Gates, G. O. 1958. A study of the herpetofauna in the vicinity of Wickenburg, Maricopa County, Arizona. *Trans. Kansas Acad. Sci.* 60:403-418.
- Jones, K. B. 1981. Effects of grazing on lizard abundance and diversity in western Arizona. *Southwest. Nat.* 26(2):107-115.
- Jones, K. B. 1985. Eumeces gilberti. *Cat. Amer. Amph. and Rept.* In Press.
- Jones, K. B., L. P. Kepner, and T. E. Martin. 1985. Species of reptiles occupying habitat islands in western Arizona: a deterministic assemblage. *Oecologia* In Press.
- Mueller-Dombois, D., and H. Ellenberg. 1974. Aims and methods of vegetation ecology. p. 110-118. John Wiley and Sons, NY.
- Ortega, A., E. Maury, and R. Barbault. 1982. Spatial organization and habitat partitioning in a mountain lizard community of Mexico. *Oecologia* 3(3):323-330.
- Pianka, E. R. 1966. Convexity, desert lizards, and spatial heterogeneity. *Ecology* 47:1055-1059.
- Pianka, E. R. 1970. Comparative autecology of the lizard Cnemidophorus tigris in different parts of its geographic range. *Ecology* 51:703-720.
- Pianka, E. R., and W. S. Parker. 1972. Ecology of the iguanid lizard Callisaurus draconoides. *Copeia* 1972:493-508.
- Price, A. H., J. L. LaPointe and J. W. Atmar. 1985. The ecology and evolutionary implications of competition and parthenogenesis in Cnemidophorus. *Biology of the Cnemidophorus.* In Press.
- Stevens, L. E., B. T. Brown, J. M. Simpson, and R. R. Johnson. 1977. The importance of riparian habitat to migrating birds. In: Importance, preservation, and management of riparian habitat: a symposium. USDA Forest Service Gen. Tech. Rp., RM-A3, p. 156-164.
- Tinkle, D. W. 1982. Results of experimental density manipulation in an Arizona lizard community. *Ecology* 63:57-65.
- Vitt, L. J. 1981. Lizard reproduction; habitat specificity and constraints on relative clutch mass. *Amer. Nat.* 117(4):506-514.
- Vitt, L. J., R. C. van Loben Sels, and R. D. Ohmart. 1981. Ecological relationships among arboreal lizards. *Ecology* 62(2): 398-410.

# Herpetofauna in Riparian Habitats Along the Colorado River in Grand Canyon<sup>1</sup>

2

Peter L. Warren and Cecil R. Schwalbe

---

Abstract.--Lizard population densities and species composition were sampled in riparian and non-riparian habitats along the Colorado River. The highest densities were found in shoreline habitats, moderate densities in riparian habitats and lowest densities in non-riparian habitats. Rapidly fluctuating river flow levels may have a deleterious effect on lizard populations by trapping populations on alluvial bars and inundating nest sites.

---

For years riparian habitats have been recognized as making a contribution to the structural diversity and species richness of natural communities that exceeds the relative areal extent of those habitats. The availability of additional water permits growth of plant species and growth forms that are lacking in the surrounding upland vegetation. Their occurrence in turn provides food and habitat resources without which some animal populations may not otherwise persist in the upland community. To most biologists these patterns are obvious, but in many cases they are surprisingly poorly documented.

Some of the best studied examples of the contribution of riparian habitat to local species density and diversity are for birds and mammals. Gallery forests of cottonwood and willow along some Southwestern rivers have been shown to have some of the highest densities of nesting birds in North America, much higher than in surrounding semiarid upland sites (Johnson et al., 1977; Anderson, Higgins and Ohmart, 1977). Riparian habitats contribute breeding sites, feeding areas and migratory routes for birds. Mammal species diversity is also higher along watercourses, where some species find necessary cover that is lacking in more open adjacent arid vegetation (Anderson, Drake and Ohmart, 1977), although small mammal

densities in upland vegetation may actually be higher.

One group that has received relatively little attention with respect to the importance of riparian habitats to their density and diversity is the reptiles. It is common to find comments in the literature about the higher density of some species in riparian sites (Lowe and Johnson, 1977; Vitt and Ohmart, 1977; Tinkle, 1982) and some studies of lizard demography have been performed in riparian areas (Tinkle, 1976; Tinkle and Dunham, 1983; Vitt and Van Loben Sels, 1976). However, quantitative studies comparing reptile density and diversity in riparian and adjacent non-riparian habitats are few. Only recently has emphasis on riparian ecosystems has begun to address effects of management practices and exotic riparian vegetation on riparian reptile communities (Szaro et al., 1985; Jakle and Getz, 1985; Jones and Glinski, 1985).

The present study was designed to examine the patterns of distribution of reptile species relative to riparian habitats along the Colorado River in Grand Canyon National Park. This work is part of a larger study to determine the effects of fluctuating flows from Glen Canyon Dam on plant and animal populations in and along the Colorado River. Data presented here were gathered during constant flow levels of approximately 40,000 cubic feet per second (cfs) in June and 25,000 cfs in August, 1984. Additional censuses will be made during lower, fluctuating flow levels. The results presented here are from the first year of a multi-year project, and are restricted to only those species for which the most data were gathered, the diurnal lizards.

---

<sup>1</sup>  
Paper presented at the First North American Riparian Conference [University of Arizona, Tucson, April 16-18, 1985].

<sup>2</sup>  
Peter L. Warren is Research Assistant at the Arizona Remote Sensing Center, Office of Arid Lands Studies, University of Arizona, Tucson, Arizona. Cecil R. Schwalbe is Herpetologist with Nongame Branch, Arizona Game and Fish Department, 2222 W. Greenway Road, Phoenix, Arizona.

## STUDY AREA

We censused lizard populations at a series of sites along the Colorado River above and in Grand Canyon National Park beginning near Lees Ferry and extending downstream 220 miles almost to Diamond Creek. The elevation at river level is approximately 945 meters (3,100 feet) at Lees Ferry and drops to 427 meters (1,400 feet) at the last census locality at mile 220. The vegetation through which the river flows is generally Mohave desertscrub. However, there is a gradual transition in species composition from more cold-tolerant species at the upper end of the study area to a flora composed of many frost-sensitive species at the lower end (Warren et al., 1982).

The riparian corridor along the river is characterized by two vegetation zones that are more or less distinct in species composition and distribution. Previous to the construction of Glen Canyon Dam in 1963 the river channel was scoured by floods on a regular basis, and the only riparian vegetation occurred as a belt along the high water line where flood disturbance was at a minimum. Since dam construction lack of large-volume flooding has permitted plants, many of them exotics, to grow along the water's edge (Turner and Karpiscak, 1980). The resulting pattern is one in which the original riparian vegetation, consisting largely of mesquite (*Prosopis glandulosa*) and cat-claw acacia (*Acacia greggii*), is perched on talus slopes and alluvial terraces several meters above the current normal water level. The new riparian vegetation, dominated by tamarisk (*Tamarix chinensis*) and arrowweed (*Tessaria sericea*), occupies sand and cobble bars along the water's edge.

## METHODS

Visual belt transects, modified from the Emlen (1971) bird census technique, were used to census the common diurnal species (Lowe and Johnson, 1977). This method involves walking a transect through representative areas of the target habitats and recording all individuals observed within a belt of predetermined width of four meters. Transect length varies with size of the habitat patch, but usually varied from 100 to 300 meters in length. Transect sites were selected to sample a range of variation within old- and new-riparian habitats and in adjacent non-riparian desertscrub. The time of day at the beginning and end of each transect was recorded as well as a temperature profile consisting of soil surface temperature, air temperature at 5 mm and air temperature at 1.5 m. Weather conditions such as cloudiness and wind speed were also noted.

As each individual lizard was sighted, the distance along the transect and the substrate upon which it was first observed were recorded, as well as its sex and age, when possible. The substrate categories used were bare soil, litter, rock (less than one meter diameter), boulder (greater than one meter diameter), cliff face, or tree. When individuals were in a tree, the tree species and height above ground were also recorded.

## Habitats Sampled

Sampling was performed in ten different habitats that are distributed in three zones relative to the river. The first zone comprised shoreline habitats within 5 meters of the river shore. The second zone included all riverine riparian vegetation greater than five meters from the river shore. The third zone included non-river habitats, both upland and riparian (Table 1).

Three distinct habitats were sampled in the river shoreline zone. These were cobble shore, rocky shore, and cliff faces at the water's edge. In all cases shoreline samples were characterized by low vegetation cover, usually less than ten percent. Cobble shores generally were characterized by numerous rocks less than 0.5 meters in diameter and rounded by erosion. Larger, uneroded boulders were absent and large patches of bare sand were occasional. Cobble shores generally were found at the mouths of tributary canyons where the coarse alluvium that forms level cobble bars was washed into the river.

Table 1.--Location of study sites at which lizard transect sampling was performed. The number of habitats sampled in each vegetation zone is indicated for each site.

Site Name	River Mile	Shore-line	River Riparian	Non-River
Lee's Ferry	-1R		1	1
Badger	8R	1		
none	16L	1		
none	20R	1		
North Canyon	20.5R	1		
none	43.5L	1		
Saddle Canyon	47R	1	3	1
Nankowep	53R	2	3	2
Kwagunt	56R	1		
Cardenas	71L	1	4	
Cremation	86L		1	
none	94L		1	
Crystal	98R	1		
Bass	108.5R	1	2	1
Elves Chasm	116.5L	1	1	
Forster	123L		2	
Tapeats	134R	1		1
none	140L	1	1	
Kanab	143.5R	1	4	
National	166L	2	1	
Stairway	171R	1	2	
none	185R	1	3	1
Whitmore	188R		3	
Parashant	198R	1	3	1
Granite Park	209L	1	1	
Three Springs	216L	1		
220 mi. Canyon	220R	1		
Total Transects		24	36	8
Total Transect Length (meters)		2665	5522	2420



In contrast, rocky shores were composed of rock fragments of varying sizes ranging from cobbles up to boulders several meters in diameter. These shores were generally composed of uneroded talus and rockfall debris and may include pockets of bare sand of varying sizes that were trapped among the boulders. In contrast to the level cobble shores, rocky shores usually fell steeply to the water's edge and were commonly very rugged and irregular.

Sandy shores and heavily vegetated shores were examined but not sampled systematically for several reasons. Heavy vegetation immediately at the water's edge was relatively uncommon. In most locations where dense cover was present near the shore it occurred on sandy soil. Frequently erosion of sandy soil along the river's edge kept the immediate shoreline free of dense cover even though adjacent sandy bars were thickly vegetated. Open sandy shorelines that lacked vegetation or rock cover were found to be almost completely free of reptile and amphibian activity, and although such sandy shores were spot-checked repeatedly, no systematic transects were sampled.

Within the riverine riparian zone five habitats were sampled. These included two that can be considered "old-zone" or pre-dam habitats, mesquite/acacia alluvial terraces and mesquite/acacia talus slopes. The remaining three

can be considered "new-zone" or post-dam habitats. These were open tamarisk with 15 to 40 percent cover, dense tamarisk with 60 to 100 percent cover, and arrowweed with cover similar to the open tamarisk.

Finally, two habitats were sampled in the non-river zone. These were desertscrub on canyon slopes generally ranging from 15 to 30 percent slope with 15 to 30 percent vegetation cover, and non-river riparian habitats along perennial tributary streams.

## RESULTS AND DISCUSSION

Sampling was performed during 18 days in June and five days in August, 1984. A total of 68 transects were sampled at 27 localities, with between one and five habitats sampled per locality (Table 1). Preliminary habitat assessments were made during September, 1983 and April, 1984.

Five common diurnal lizard species were successfully sampled using the belt transect method. One lizard species (Holbrookia maculata), two toad species (Bufo punctatus and B. woodhousei), one frog species (Hyla arenicolor), and three snake species (Crotalus viridis, Masticophis taeniatus, and M. flagellum) were encountered in numbers too small for adequate conclusions to be drawn concerning distribution patterns.

Table 2.--Distribution of lizard occurrence on different substrates along the Colorado River in Grand Canyon, June and August, 1984. Numbers in parentheses indicate the percent of individuals of each species that were observed on each substrate.

Species	Substrate						Total
	Litter	Bare Soil	Rock <1m	Boulder >1m	Cliff	Tree	
<u>Uta stansburiana</u>	2 (1.3)	70 (46.7)	71 (47.3)	2 (1.3)	1 (0.7)	4 (2.7)	150
<u>Cnemidophorus tigris</u>	9 (9.5)	78 (82.1)	4 (4.2)	3 (3.2)	0	1 (1.1)	95
<u>Sceloporus magister</u>	11 (12.5)	11 (12.5)	7 (8.0)	34 (38.6)	3 (3.4)	22 (25.0)	88
<u>Urosaurus ornatus</u>	3 (4.9)	1 (1.6)	9 (14.7)	16 (26.2)	27 (44.3)	5 (8.2)	61
<u>Crotaphytus insularis</u>	0	1 (14.3)	4 (57.1)	2 (28.6)	0	0	7
<u>Sauromalus obesus</u>	0	0	0	1 (100)	0	0	1
<u>Holbrookia maculata</u>	0	1 (100)	0	0	0	0	1
Total	25	162	95	58	40	32	403

The lizards showed strong species-specific patterns of substrate preference (Table 2). All species were observed most frequently on a substrate different from any other species, although four species were commonly observed along a single transect in one habitat.

Side-blotched lizards (*Uta stansburiana*) were the most common species observed as well as the smallest. Utas were found predominately in open sites and the substrates upon which they were most frequently observed were rocks less than one meter in diameter and bare soil. They were almost never seen at a distance greater than one meter away from cover in the form of rocks or small shrubs.

Western whiptail lizards (*Cnemidophorus tigris*), the second most abundant species, were found most frequently on bare soil or litter. They frequently occurred in the same habitats with Uta, but were rarely seen perched on small rocks as Uta does. Cnemidophorus was the only species observed commonly roaming up to several meters across bare sand away from cover.

Desert spiny lizards (*Sceloporus magister*) were approximately equal in abundance to Cnemidophorus, although they were less noticeable due to more sedentary habits and preference for cryptic substrates with a strong vertical component, such as large boulders and trees. Desert spiny lizards were seen most commonly on boulders larger than one meter in diameter, and usually on those with fractures and crevices. At sites that lacked boulders but had trees, such as tamarisk stands on sand bars, this species was also found on larger tree trunks. On those occasions when they were observed on the ground, they were almost invariably at the immediate base of a large tree or boulder.

Tree lizards, *Urosaurus ornatus*, were also found on substrates with a strong vertical component. However, they showed a clear preference for sheer, vertical rock faces on cliffs or large boulders. The highest densities of tree lizards were found on cliff faces that dropped vertically into the river, usually along eddies or quiet stretches. They often sat less than one meter above water level, just above the splash zone, on faces that had no fractures or other protection and that were up to 20 to 40 meters away from the nearest water-level alluvial soil.

Black collared lizards, *Crotaphytus insularis*, and chuckwallas, *Sauromalus obesus*, were observed much less frequently than the four preceding species. These two species also differed from the others insofar as both species were seen more often in desertscrub than in the riparian corridor. Collared lizards generally were observed perched on rocks or small boulders that were approximately one meter in diameter or slightly smaller. Chuckwallas rarely were seen on transects, but additional observations indicated that they preferred deeply fractured boulders and rock outcrops.

The most striking observation was the large differences in lizard densities among the habitats sampled (Table 3). Total lizard densities were highest in shoreline and open, "new zone" riparian habitats and lowest in desertscrub, with intermediate densities in "old zone" sites. Most of the individual species followed the same pattern with highest densities in shoreline and "new zone" habitats and lowest density in desertscrub. The only exception to this pattern were collared lizards which, although relatively rare, were seen more commonly in desertscrub than any other habitat.

The pattern of differences in lizard densities among habitats was stable through time as shown by comparison of June and August data (Fig. 1). Regression analysis of density data gathered in the same habitats during two months indicates that although overall observed densities declined from June to August, the ranking of habitats based on density remained the same. This was possibly the result of cooler, cloudier weather encountered during the August census and consequent lower activity levels of some species. Whiptails and desert spiny lizards both declined in observed densities by approximately one-half between the two census periods.

Comparison of density values derived from visual transects in this study with density data available in the literature is difficult for several reasons. First and most important is that our visual census does not attempt to account for every lizard in the study site as a mark/recapture study on a permanent grid does. Visual transect estimates will therefore generally be lower than a comparable mark/recapture estimate. Second, lizard densities vary to large degree between sites, between years, and even seasons or days, at a single site. Thus any comparison of densities, regardless of the sample technique, is fraught with problems unless the sampling is performed simultaneously at all sites to be compared. With these problems in mind, it is still useful to compare our results with those density data that are available in the literature.

In general the lizard densities observed along the Colorado River fell within the range of values that have been observed for these species in other areas (Table 4). That species which we observed to occur in the highest density, *Urosaurus ornatus*, was also reported by several authors to have the highest density of lizard species studied. Similarly, of the four most common species, we generally found *Sceloporus magister* to have the lowest density. This species was reported by several authors usually to have lower densities than the other three common species. These results indicate that visual transect data are roughly comparable with mark/recapture data.

The observed average June densities of 858 lizards per hectare on shoreline cliff-faces and 300 lizards per hectare in non-river riparian habitats equal or exceed lizard densities reported

Table 3.--Lizard densities in habitats along the Colorado River in Grand Canyon, Arizona during June and August, 1984. Values indicate number of individuals encountered per hectare.

Habitat	Month	Lizard Species					All Lizards
		<u>Uta</u>	<u>Cnemi- dophorus</u>	<u>Scelop- orus</u>	<u>Uro- saurus</u>	<u>Crota- phytus</u>	
<b><u>Shoreline (&lt;5m):</u></b>							
Rocky Shore	June	48	23	60	20	0	150
	Aug.	20	0	0	100	0	120
Cobble Bar	June	68	40	15	0	3	125
	Aug.	60	18	13	0	0	90
Cliff Face	June	0	0	0	858	0	858
	Aug.	0	0	0	223	0	223
<b><u>River Riparian (&gt;5m):</u></b>							
<u>New Zone</u>							
Open Tamarisk	June	53	78	55	13	0	195
	Aug.	53	60	60	0	0	173
Arrowweed	June	35	35	5	0	0	73
	Aug.	33	18	18	0	0	68
Dense Tamarisk	June	0	13	40	0	0	53
	Aug.	no sample					
<u>Old Zone</u>							
Terrace	June	30	15	15	3	1	65
	Aug.	0	0	13	25	0	38
Talus	June	28	10	15	0	0	53
	Aug.	no sample					
<b><u>Non-River:</u></b>							
Desertscrub	June	18	8	5	0	2	30
	Aug.	5	5	0	0	5	15
Riparian	June	25	0	125	150	0	300
	Aug.	208	0	0	0	0	208
Grand Mean (All habitats)	June	35	25	23	10	0.7	93
	Aug.	30	13	13	23	1	80

in the literature for any habitat. This observation is of particular interest considering the expected under-estimate of visual census compared to mark/recapture methods discussed above. The lizard densities we observed in riparian habitats along the Colorado River were higher than those in most habitats thusfar documented in the Southwest. They were up to an order of magnitude higher than densities in desertscrub immediately adjacent to the river corridor.

The most likely explanation for these high densities is an increased abundance of food

resources. Many shoreline sites appear to have much greater numbers of insects than non-riparian areas for two major reasons. First, debris washed up along the water's edge in eddies and backwaters is frequented by many insects. Second, many riparian plant species support a larger insect fauna than non-riparian species (Stevens, 1976). The highest local lizard densities observed anywhere along the river were both at sites along the shoreline where lizards were feeding upon insects. The highest density was observed at Cardenas where a total of eight Cnemidophorus tigris and five Sceloporus magister were observed feeding along the shoreline in an area of

Table 4.--Comparison of average lizard densities in Grand Canyon with those from other localities. Ranges are shown in parentheses. In some cases the range of values are from replicate sampling in adjacent sites, and in some cases from sampling in different years. The range of values is not published in all cases.

Species	Average Density (Number/Ha)	Location	Source
<u>Uta</u>	140 (62-238)	Texas	Tinkle, 1967
<u>stansburiana</u>	22	Ariz. desertscrub	Vitt & Van Loben Sels 1976
	7	Ariz. mesquite	" "
	7	Ariz. riparian	" "
	33 (0-208)	All habitats	This study
<u>Cnemidophorus</u>	12 (8-18)	Nevada	Turner, et al, 1969
<u>tigris</u>	8 (3-15)	Texas	Degenhardt, 1966
	17	Colorado	McCoy, 1965
	30	Nevada	Tanner & Jorgensen, 1963
	114 (45-184)	Texas	Milstead, 1965
	3	Ariz. grassland	Lowe & Johnson, 1977
	12	Ariz. desertscrub	Vitt & Van Loben Sels, 1976
	32	Ariz. mesquite	" "
	32	Ariz. riparian	" "
	7	Ariz. dry wash	" "
	19 (0-78)	All habitats	This study
<u>Sceloporus</u>	15	Utah, riparian	Tinkle, 1976
<u>magister</u>	10	Ariz. desertscrub	Vitt & Van Loben Sels, 1976
	25	Ariz. mesquite	" "
	25	Ariz. riparian	" "
	18 (0-125)	All habitats	This study
<u>Urosaurus</u>	158 (131-188)	Ariz., spring	Tinkle & Dunham, 1983
<u>ornatus</u>	101 (42-161)	Ariz., summer	" "
	370	Ariz. mesquite	Vitt & Van Loben Sels, 1976
	185	Ariz. riparian	" "
	16 (0-858)	All habitats	This study
Total	6 (2-12)	Southwest deserts	Pianka, 1967
Lizards	55	Ariz. riparian	Lowe & Johnson, 1977
	66	Ariz. grassland	" "
	8	Ariz. Chihuahuan desert	" "
	593	Ariz. mesquite	Vitt & Van Loben Sels, 1976
	277	Ariz. riparian	" "
	89	Ariz. Sonoran desert	" "
	12	Ariz. dry wash	" "
	86 (15-858)	All habitats	This study

approximately three by seven meters, or a density equivalent to 6,500 lizards per hectare!! In spite of their close proximity to one another, no antagonistic interactions were observed between individuals of either species, all of which were active in the area for an hour. The second highest density was observed on a vertical rock face at the waterline on which eight Urosaurus ornatus were observed in an area of two by twenty-five meters, or 1,600 per hectare. Again, they were feeding on insects at the waters edge.

Reproductive activity of lizards along the Colorado River was not evaluated directly, but indirect evidence of reproduction was inferred from the distribution of first year immature individuals. The greatest number of immature lizards were observed in shoreline and riparian

habitats that contained a mosaic of bare sand and cover such as cobbles and small shrubs. Uta juveniles were the most common and were often seen on cobble bars and shoreline. Tinkle's (1967) observations that average first-year dispersal of juvenile Utas is less than six meters suggests that these habitats are the location of higher reproductive activity than non-riparian sites. Future study of nest site selection will clarify the level of reproductive activity in the different habitats.

The distributions of several of the lizard species studied were consistent with the concept of "preferential" riparian species as used by Johnson et al. (1984) in their discussion of plant species distributions. Urosaurus, Cnemidophorus, Sceloporus and Uta could be considered

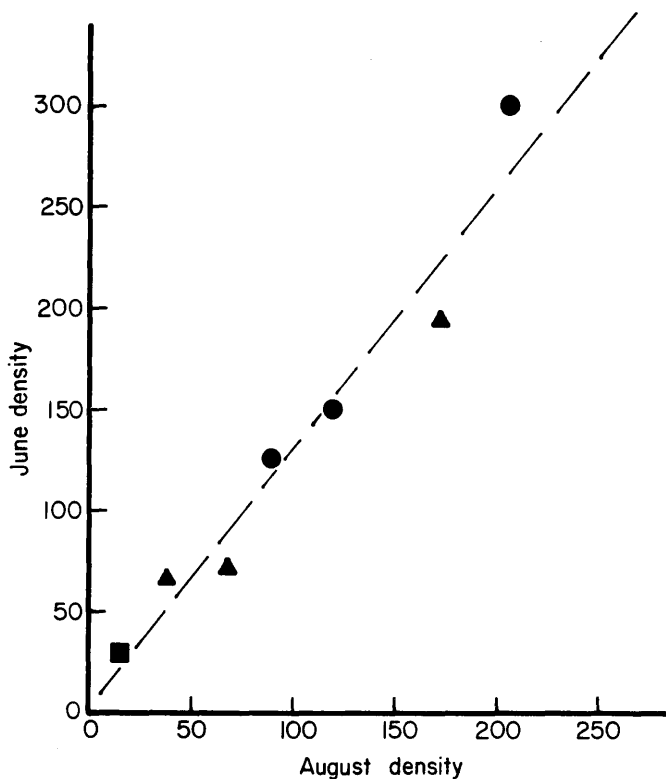

Figure 1.--Comparison of average total lizard densities for two dates in seven habitats along the Colorado River in Grand Canyon. Circles indicate shoreline habitats (less than 5 meters from shoreline), triangles indicate riparian habitats (greater than 5 meters from shoreline), and square indicates desertscrub. Regression equation is  $y=1.28x + 3.75$  ( $r=0.98$ ,  $n=7$ ).

"preferential" riparian species by virtue of their higher densities in riparian habitats compared to non-riparian. As with the original application of these terms to plant distributions, it is important to note that these classifications refer only to local distribution and do not apply throughout the species' ranges.

#### CONCLUSIONS

Shoreline lizard densities along the Colorado River were found to be higher than densities in riverine riparian vegetation, which in turn were higher than non-riparian desertscrub densities. Shoreline densities for the four most common species were higher than densities previously reported for those species anywhere else in the southwest. The reason for the high densities observed is probably high food availability on riparian plants and on debris along the water's edge.

It is possible that rapidly fluctuating river flow levels will have deleterious effects on shoreline lizard populations for two reasons. First, rapidly rising water could trap and destroy large numbers of individuals on alluvial bars, and

second, rising water during the breeding season from May to July may inundate nest sites in shoreline and riparian-zone sand.

#### ACKNOWLEDGEMENTS

This research was supported by the Bureau of Reclamation and the Arizona Game and Fish Department as part of the Glen Canyon Environmental Studies through cooperative agreement 4-A6-40-01810. The National Park Service provided collection permits. Park Service personnel, especially John Thomas, Steven Carothers, James Gaddy, and Jon Dick, assisted with logistics. Many Arizona Game and Fish personnel contributed to various aspects of project initiation and field work including James C. DeVos, Jr., Terry Johnson, Ray Lee, Henry Maddux, William Persons, and Bruce Taubert. Terry B. Johnson reviewed the manuscript. Humphrey Summit Associates provided cheerful, professional logistic support.

#### LITERATURE CITED

- Anderson, B.W., A.E. Higgins and R.D. Ohmart. 1977. Avian use of saltcedar communities in the lower Colorado River valley. *In* Importance, Preservation and Management of Riparian Habitats: a Symposium. U.S.D.A. Forest Service Gen. Tech. Rep. RM-43 p. 128-136.
- Anderson, B.W., J.F. Drake and R.D. Ohmart. 1977. Population fluctuations in nocturnal rodents of the in the lower Colorado River valley. *In* Importance, Preservation and Management of Riparian Habitats: a Symposium. U.S.D.A. Forest Service Gen. Tech. Rep. RM-43 p. 183-192.
- Carothers, S.W. and S.W. Aitchison, eds. 1976. An ecological survey of the riparian zone of the Colorado River between Lees Ferry and the Grand Wash Cliffs, Arizona. Tech. Rept. No. 10, Grand Canyon National Park, Colorado River Research Series. 251 pp.
- Emlen, J.T. 1971. Population densities of birds derived from transect counts. *Auk*. 88:323-342.
- Degenhardt, W.G. 1966. A method of counting some diurnal ground lizards of the genera *Holbrookia* and *Cnemidophorus* with results from the Big Bend National Park. *Amer. Midland Natur.* 74:61-100.
- Jakle, M.D. and T.A. Gatz. 1985. Herpetofauna use of four habitat types of the middle Gila River drainage, Arizona. This conference.
- Johnson, R.R., L.T. Haight and J.M. Simpson. 1977. Endangered species vs. endangered habitats: a concept. *In* Importance, Management and Preservation of Riparian Habitats: a Symposium. U.S.D.A. Forest Service Gen. Tech. Rep. RM-43 p. 68-79.

- Johnson, R.R., P.L. Warren, L.S. Anderson and C.H. Lowe. 1984. Stream order in ephemeral watercourses: a preliminary analysis from the Sonoran Desert. Proc. Amer. Water Resources Assoc.--Southwestern Div. 14:89-100.
- Johnson, T.B. and C.H. Lowe. 1978. A survey of the amphibians and reptiles of Coronado National Memorial. Tech. Rept. No. 5, Coop. Nat. Park Resources Studies Unit, University of Arizona, Tucson.
- Jones, K.B. and P. Glinski. 1985. Microhabitats of lizards in a Southwestern riparian community. This conference.
- Lowe, C.H. and T.B. Johnson. 1977. Fishes, amphibians and reptiles of the Rosemont site. In R. Davis and J.R. Callahan, eds. An environmental inventory of the Rosemont area in southern Arizona. University of Arizona, Dept. of Biological Sciences. Unpublished report.
- McCoy, C.J., Jr. 1965. Life history of and ecology of Cnemidophorus tigris septentrionalis. Ph.D. diss. Univ. of Colorado, Boulder.
- Milstead, W.W. 1967. Lizard ecology - a symposium. University of Missouri Press, Columbia. 300 pp.
- Pianka, E.R. 1967. On lizard species diversity: North American flatland deserts. Ecology. 48:333-351.
- Stevens, L.E. 1976. Insect production of native and introduced dominant plant species. In: S.W. Carothers and S.W. Aitchison, eds. An ecological survey of the riparian zone of the Colorado River between Lee's Ferry and the Grand Wash Cliffs, Arizona. Grand Canyon National Park Colorado River Research Series Contr. No. 38.
- Szaro, R.C., S.C. Bellfit, J.K. Aitkin and J.N. Rinne. 1985. A preliminary study on the impact of grazing on riparian garter snakes. This conference.
- Tanner, W.W. and C.D. Jorgensen. 1963. Reptiles of the Nevada Test Site. Brigham Young University Sci. Bull., Biol. Series III(3). 31 p.
- Tinkle, D.W. 1967. Home range, density, dynamics, and structure of a Texas population of the lizard Uta stansburiana. In: W.W. Milstead, ed. Lizard ecology-a symposium. Univ. Miss. Press. p. 5-29.
- \_\_\_\_\_. 1976. Comparative data on the population ecology of the desert spiny lizard, Sceloporus magister. Herpetologica. 32:1-6.
- \_\_\_\_\_. 1982. Results of experimental density manipulation in an Arizona lizard community. Ecology. 63:57-65.
- Tinkle, D.W. and A.E. Dunham. 1983. Demography of the tree lizard, Urosaurus ornatus, in central Arizona. Copeia. 1983:585-598.
- Turner, F.B., P.A. Medica, J.R. Lannom Jr. and G.A. Hoddenbach. 1969. A demographic analysis of fenced populations of the whiptail lizard, Cnemidophorus tigris, in southern Nevada. Southwestern Naturalist. 14:189-202.
- Turner, R.M. and M.M. Karpiscak. 1980. Recent vegetation changes along the Colorado River between Glen Canyon Dam and Lake Mead, Arizona. U.S.G.S. Prof. Paper No. 1132.
- Vitt, L.J. and R.D. Ohmart. 1977. Ecology and reproduction of lower Colorado River lizards: II. Cnemidophorus tigris (Teiidae), with comparisons. Herpetologica. 33:223-234.
- Vitt, L.J. and R.C. Van Loben Sels. 1976. The herpetofauna of the Orme Dam site. Arizona State University, Dept. of Zoology. Unpublished report. 57 pp.
- Warren, P.L., K.L. Reichhardt, D.A. Mouat, B.T. Brown and R.R. Johnson. 1982. Vegetation of Grand Canyon National Park. Coop. National Park Resources Studies Unit Tech. Rep. No. 9, University of Arizona. 140 pp.

# Herpetofaunal Use of Four Habitats of the Middle Gila River Drainage, Arizona<sup>1</sup>

Martin D. Jakle and Thomas A. Gatz<sup>2</sup>

---

Abstract.--Data on reptiles and amphibians were gathered using pit-fall traps and by observation along the Gila River northeast of Florence, Pinal County, Arizona. Four habitat types were sampled: desert wash, desert upland, mature salt cedar, and mesquite bosque. A total of 104 individuals of 12 species were trapped and an additional seven species were observed. Based on trap data, species diversity was greatest in the desert wash, and lowest in the salt cedar habitat. Reptiles and amphibians showed little use of the salt cedar habitat which may reflect the lack of structural diversity in the herbaceous and shrub layers and reduced light penetration due to a dense canopy.

---

## INTRODUCTION

Increasing attention is being focused on riparian habitat because of its recognized high values for wildlife and its rapidly dwindling supply. Stream diversions, reservoir construction, ground water overdraft, grazing, phreatophyte clearing, recreational demands, and other uses are taking their toll on a habitat type that naturally occupies a small percentage of the total landmass. Several workers have documented the importance of riparian habitats to birds in the Southwest (Carothers et al., 1974; Stevens et al., 1977; Szaro and Jakle, in press); however, few researchers have studied the Southwestern riparian herpetofauna. This paper discusses the herpetofauna of two riparian and two desert habitats in Arizona.

## STUDY AREA AND HABITAT DESCRIPTION

The study area is located in southcentral Arizona 21 km east of Florence, Pinal County, at an elevation of 500 m. The dominant plant community in this area is the Sonoran desert scrub formation and, more specifically, the palo verde-cacti-mixed shrub series (Brown 1982). The Gila River flows through this area and forms a riparian corridor.

The salt cedar habitat was a strip of mature trees bordering the Gila River. The strip was approximately 350 m by 45 m, composed of an even-aged stand of mature trees. The stand had little species diversity, being composed of almost 100 percent salt cedar trees (Tamarix pentandra) which were quite dense, and formed a thicket. The density of the stand reduced light penetration and precluded establishment of a herbaceous layer.

The mesquite bosque habitat also bordered the Gila River, adjacent to the salt cedar habitat and was approximately 1 km by 75 m. Mature mesquite trees (Prosopis velutina) were the dominant species present, but the stand was a heterogeneous mix which included Goodding willow (Salix gooddingii) and cottonwood (Populus fremontii). This habitat type had greater structural diversity which included a shrub and herbaceous layer.

The surrounding area consisted of two habitats: desert upland and desert wash. In the desert upland habitat the dominant tree species were foothill palo verde (Cercidium microphyllum) and saguaro (Carnegiea gigantea). The dominant shrubs consisted of triangle leaf bursage (Ambrosia deltoidea), which was by far the most abundant, and ratany (Krameria parvifolia). The herbaceous layer consisted primarily of an annual grass, red brome (Bromus rubens), which grew mainly under nurse plants.

The desert wash was located in a large sandy, ephemeral drainage course, Donnelly Wash, which emptied into the Gila River. This habitat was patchy, consisting of large sandy areas devoid of any vegetation interspersed with vegetated areas. The dominant tree species were blue palo verde (Cercidium floridum), ironwood (Olneya tesota), and mesquite. Canyon ragweed (Ambrosia ambrosioides), wolfberry (Lycium andersonii), and gray thorn (Zizyphus obtusifolia) were the dominant shrubs; red brome dominated the herbaceous layer.

---

<sup>1</sup>Paper presented at the North American Riparian Conference, April 16-18, 1985, Tucson, Arizona.

<sup>2</sup>Respectively, General Biologist and Supervisory Biologist, U.S. Bureau of Reclamation, Phoenix, Arizona 85068.

## METHODS

The herpetological array pit-fall trapping technique developed by Campbell and Christman (1982) and modified by Jones (1980) was used to determine species composition and relative abundance of reptiles and amphibians in the four habitat types. This method uses four 18.4 l pit-fall traps. One trap is located in the center and connected to three peripheral traps by 7.2 m aluminum flashing which extends from the center trap at equal angles. Two arrays each were placed in the desert wash, desert upland, and mesquite bosque habitats, and one in the salt cedar habitat. Trapping commenced on March 23, 1983, in the desert habitats and 6 to 15 days later in the riparian habitats. Trapping ended May 5, 1983.

Traps were checked at least weekly. All captured lizards were toe-clipped, weighed, measured, sexed, and released at the capture site. Recaptured individuals were not used to determine diversity or abundance. Species diversity was calculated based on the formula of Shannon and Weaver (1948).

## RESULTS

A total of 104 reptiles and amphibians were trapped during 406 trap days between March 23 and May 5, 1985, an average of 0.26 individuals per trap day for all habitats combined. The desert upland and desert wash habitats had the highest trap success, 0.31 individuals per trap day. The mesquite habitat had the next highest trap success, 0.22 individuals per trap day and the salt cedar habitat had the lowest value with 0.06 individuals per trap day. There was a significant difference between the number of individuals captured in these two adjacent riparian habitats (Chi Square Test =  $p < .01$ ). A total of twelve species were trapped (table 1). The greatest species diversity (1.81) was found in the desert wash and the lowest (0.63) was found in the salt cedar (table 1).

A total of 21 species of reptiles and amphibians were trapped or observed in the study area (tables 1 and 2). Species which were only observed, and not trapped, were primarily large snakes.

Seven species of reptiles and amphibians were collected in only one habitat; five species were only trapped in the desert wash and two only in the desert upland. The western whiptail lizard (*Cnemidophorus tigris*) was the most abundant species in all habitats except salt cedar, where it did not occur. Two additional species, the tree lizard (*Urosaurus ornatus*) and desert spiny lizard (*Sceloporus magister*), were found in three of the four habitats.

## DISCUSSION

Based on pit-fall trapping data, the desert wash habitat had the highest species diversity and equaled the desert upland as having the highest abundance of the four habitats studied. The high value of this habitat, i.e. palo verde-cacti-mixed shrub, is supported by deVos et al. (1983). In a study west of Tucson, Arizona, this habitat had the greatest reptile and amphibian diversity of the five habitats studied: palo verde-mixed cacti, creosote-bursage, desert grassland, mesquite bosque, mixed riparian woodland.

Although the salt cedar habitat had the lowest density and diversity of all habitats studied, the occurrence of 3 individual lizards of two species is noteworthy. K. Bruce Jones<sup>3</sup>, in several studies of salt cedar, has never collected any reptiles in this habitat type. Jakle and Baucom<sup>4</sup> conducted a bird census in a mixed salt cedar and Goodding willow habitat at Picacho Reservoir in central Arizona. During the census only two individuals--a desert spiny lizard (*Sceloporus magister*) and a coachwhip (*Masticophis flagellum*)--were recorded in 17 km of bird transects. Reptile populations were studied at Whitlow Dam in central Arizona by Szaro and Belfit (in press). They reported low numbers of reptiles and amphibians in a riparian habitat consisting of 78 percent Goodding willow and 22 percent salt cedar.

These studies all report a depauperate herpetofauna in riparian habitats which were composed of either salt cedar or a mixture of Goodding willow and salt cedar. Szaro and Belfit (in press) hypothesize that the recent development of the riparian habitat behind Whitlow Dam (the dam was constructed in 1959) and its isolation from other such habitats may explain the relative lack of reptiles. This area has no naturally occurring relict riparian species nor has there been any recent colonization. Jones et al (in press) found that even naturally occurring riparian habitats rapidly lose "riparian or upland" species as they become more isolated. However, another factor that all these habitats have in common is a dense canopy. The dense canopy reduces light penetration and inhibits the development of shrubs and a herbaceous layer of ground cover. Indeed, Pianka (1966) studied lizard populations in the western United States and reported a strong positive correlation between structural diversity and the total number of lizard species.

<sup>3</sup>Jones, K.B. 1983. Personal conversation, U.S. Bureau of Land Management, Phoenix Training Center, Phoenix, Arizona.

<sup>4</sup>Jakle, M.D. and F.M. Baucom. 1983. An inventory of birds and fish of Picacho Reservoir. Unpublished report, Bureau of Reclamation, Phoenix, Arizona.



Table 1.--Summary of amphibian and reptile abundance based on pit-fall trap data from the four habitat types of the Florence study area, Pinal County, Arizona

Species	Habitat Type				Total Individuals
	Desert Upland	Desert Wash	Mesquite Riparian	Salt Cedar Riparian	
<u>Bufo punctatus</u>	1 <sup>1/</sup> (.008) <sup>2/</sup>		2 (.02)		3 (.007)
<u>Callisaurus draconoides</u>		6 (0.5)			6 (.05)
<u>Cnemidophorus tigris</u>	19 (.15)	10 (.08)	14 (.13)		43 (.10)
<u>Gambelia wislizenii</u>	1 (.008)				1 (.008)
<u>Holbrookia texana</u>		1 (.008)			1 (.002)
<u>Phrynosoma solare</u>		1 (.008)			1 (.002)
<u>Sceloporus magister</u>		4 (.03)	5 (.05)	2 (.05)	11 (.03)
<u>Urosaurus ornatus</u>		10 (.03)	2 (.2)	1 (.01)	13 (.03)
<u>Uta stansburiana</u>	17 (.13)	5 (.04)			22 (.05)
<u>Chilomeniscus cinctus</u>		1 (.008)			1 (.002)
<u>Leptotyphlops humilis</u>		1 (.008)			1 (.002)
<u>Tantilla planiceps</u>	1 (.008)				1 (.002)
Total Individuals	39 (.31)	39 (.31)	23 (.22)	3 (.06)	104 (.26)
Total Species	5	9	4	2	12
Total Trap Days	126	126	106	48	406
Species Diversity	.98	1.81	1.05	.63	

<sup>1/</sup> Indicates number caught

<sup>2/</sup> Indicates number caught per trap day

Table 2.--Summary of amphibian and reptiles observed but not trapped in the four habitat types of the Florence study area, Pinal County, Arizona

Species	Habitat Type			
	Desert Upland	Desert Wash	Mesquite Riparian	Salt Cedar Riparian
<u>Bufo woodhousei</u>	x			
<u>Coleonyx variegatus</u>	x			
<u>Heloderma suspectum</u>	x			
<u>Masticophis flagellum</u>	x		x	
<u>Masticophis bilineatus</u>			x	
<u>Salvadora hexalepis</u>	x			
<u>Pituophis melanoleucus</u>	x			
<u>Rhinocheilus lecontei</u>			x	
<u>Crotalus atrox</u>	x	x	x	

In the present study there was a significant difference between the number of reptiles captured in the two adjacent riparian habitats. A major difference between these two habitats besides plant species composition was habitat structure. The mesquite bosque habitat had a well-developed herbaceous and shrub layer, the salt cedar did not because of its dense canopy. The reason salt cedar habitat lacked these layers was due to its dense canopy which reduced light penetration. In addition to reducing structural diversity, reduced light penetration also limited the number of basking sites which are important to heliothermic species. It is likely that the lack of structural diversity and reduced light in a habitat limits reptile and amphibian use.

The three individual lizards captured in the salt cedar habitat were most likely strays from nearby habitats. As previously stated, the salt cedar habitat was a narrow band; the trapping array was approximately 15 m from the edge of this habitat type.

The pit-trapping technique we used worked well for the smaller species of reptiles and amphibians but did not adequately sample larger species. Pit traps left in place for prolonged periods of time may also attract predators that eventually key in to the traps as a ready source of easily captured prey. On one occasion we recorded a large leopard lizard (*Gambelia wislizenii*) escaping from a pit trap. This species is known to prey on smaller lizards (Stebbins 1966). By not trapping into the summer rainy season, we also precluded getting an adequate indication of the toad population in the study area.

#### SUMMARY AND CONCLUSIONS

A total of 21 species of reptiles and amphibians were either trapped or observed in the study area. The desert habitats, desert wash and upland, had higher species diversity and total number of individuals than the riparian areas. The desert wash had the highest number of habitat specific species, five in comparison to the desert upland which had two. The difference between the two adjacent riparian habitats was pronounced. Only three individuals of two species were collected in the salt cedar habitat which was significantly lower than any of the other habitats sampled. The reason for this paucity of herpetofauna suggested by the authors is its lack of structural diversity and basking sites resulting from a closed canopy which reduced light penetration.

#### ACKNOWLEDGEMENTS

Our thanks go to Bruce Jones for his help in the design of this study, data collection and review of this manuscript. Our thanks also go to Frank Baucom, Tice Supplee and the Bureau of Land Management Wildlife Training Class for their field assistance, and Scott Belfit, John Morgart, and Robert Szaro for their review of this manuscript.

#### LITERATURE CITED

- Brown, D.E. 1982. Biotic communities of the American Southwest--United States and Mexico. *Desert Plants* 4:200-202.
- Campbell, H.W. and S.P. Christman. 1982. Field techniques for herpetofauna community analysis. *Herpetological Communities*. USDI Fish and Wildlife Service, Wildlife Research Report 13, 239 pp.
- Carothers, S.W., R.R. Johnson, and S.W. Aitchison. 1974. Population structure and social organization of southwestern riparian birds. *Amer. Zool.* 14:97-108.
- deVos, J.C., C.R. Miller, S.L. Walchuk, N.D. Ough, and D.E. Taylor. 1983. Final report for the biological resource inventory: Tucson Division--Phase B, Central Arizona Project Aqueduct. Contract No. 32-V0151, U.S. Bureau of Reclamation, Phoenix, Arizona.
- Jones, K.B. 1980. Distribution, ecology and habitat management of the reptiles and amphibians of the Hualapai-Aquarius Planning Area, Mohave and Yavapai Counties, Arizona. U.S. Bureau of Land Management Technical Note No. 353, 134 pp.
- Jones, K.B., L.P. Kepner and T.E. Martin. In press. Species of reptiles occupying habitat islands in western Arizona: a deterministic assemblage. *Oecologia*.
- Pianka, E.R. 1966. Convexity, desert lizards, and spatial heterogeneity. *Ecology* 48: 1055-1059.
- Shannon, C.E., and W. Weaver. 1948. The mathematical theory of communication, University Illinois Press, Urbana, IL.
- Stebbins, R.C. 1966. A field guide to western reptiles and amphibians. Houghton Mifflin Co., Boston, MA. 279 pp.
- Stevens, L.E., B.T. Brown, J.M. Simpson, and R.R. Johnson. 1977. The importance of riparian habitat to migrating birds. In importance, preservation, and management of riparian habitat: A symposium. R.R. Johnson and D.A. Jones, Tech. Coord., U.S.D.A. Forest Service General Technical Report, RM-A3, pp. 156-164.
- Szaro, R.C. and M.D. Jakle. In press. Avian use of desert riparian and scrub habitats. *Condor*.
- Szaro, R.C. and S. C. Belfit. In press. The influence of a flood control dam on a central Arizona herpetofauna. *J. of Appl. Ecology*.

# Impact of Grazing on a Riparian Garter Snake<sup>1</sup>

Robert C. Szaro, Scott C. Belfit, J. Kevin Aitkin, and John N. Rinne<sup>2</sup>

---

Abstract.--Numbers of wandering garter snakes (*Thamnophis elegans vagrans*) were significantly higher where cattle grazing was excluded than along grazed portions of Rio de las Vacas, a high elevation thin-leaf alder - willow riparian community in northern New Mexico. Differences can be attributed to the regeneration of streamside vegetation and the increased amount of organic debris.

---

## INTRODUCTION

Riparian habitats of the southwestern United States are widely recognized as being critical to wildlife communities (Ohmart and Anderson 1982). However, little is known about the microhabitat requirements of many riparian species, particularly reptiles and amphibians. Even less is known about how these animals are impacted by changes in the structure and composition of plant communities brought about by grazing and other habitat modifications (Jones 1981). Numerous studies on the habitat requirements (Fleharty 1967, Scott et al. 1982, White and Kolb 1974) and diet (Arnold and Wassersug 1978, Campbell 1969, Drummond 1983, Gregory et al. 1980, Kephart and Arnold 1982) of the wandering garter snake (*Thamnophis elegans vagrans*) have been published, but Fitch (1940), Drummond and Burghardt (1983) and others have demonstrated large variations in the ecological characteristics between local populations of this abundant and wide-ranging species (fig. 1). The primary objective of this study, therefore, was to document the effects of domestic livestock grazing upon a riparian population of wandering garter snakes by comparing snake abundances and habitat parameters between a grazed stream section and a nongrazed enclosure. Food habits and habitat use patterns

were determined in order to help explain differences in abundance between the two sites.

## SITE DESCRIPTION

The study area is along the Rio de las Vacas, a third-order montane stream draining the San Pedro Parks Wilderness Area, Santa Fe National Forest, New Mexico. The area is about 17 km southeast of Cuba in Sandoval County, at a longitude of 106° 46' 30" and latitude of 35° 55' 57" north (T20N R1E S12). The site is at an elevation of 2,600 m.

The surrounding watershed is primarily mixed conifer on the north-facing slopes and ponderosa pine (*Pinus ponderosa*) interspersed with grassy meadows on the south-facing slopes. Under low flow conditions, stream width ranged from 2.8 to 10.5 m and averaged 7.6 m (Rinne 1985). Stream gradient is low ranging from 0.5 to 2.0%.

Two cattle enclosures each about a kilometer long and 50 m wide, straddle the stream. Vegetation within both enclosures is utilized by elk (*Cervus canadensis*) and beaver (*Castor canadensis*). The enclosures, established in 1972 and 1975, are within the Cuba Community Allotment of approximately 11,600 ha. Within the allotment there are 610 ha of private land (5.3%), 680 ha of riparian grassy meadows and shrubland (5.8%), and 5,675 ha of no-allowable-capacity lands (48.9%). No-allowable-capacity lands fall into two broad categories 1) areas under natural conditions that are not capable of producing vegetation, i.e., barren rock outcrops, talus slopes, etc. and 2) areas where the soil is not capable of producing more vegetation than is needed to prevent erosion. From 1949 to 1980 an average of 448 cattle (2,688 AUM) have been grazed on a continuous, season-long basis (June 1 to October 31). Since 1980, grazing has continued on this basis but will be altered to a 3-pasture rest-rotation system in the near future.

---

<sup>1</sup> Paper presented at the Symposium, Riparian Ecosystems and Their Management: Reconciling Conflicting Uses, April 16-18, 1985, Tucson, Arizona.

<sup>2</sup> Robert C. Szaro is Research Wildlife Biologist, Scott C. Belfit and J. Kevin Aitkin are Biological Technicians, and John N. Rinne is Research Fisheries Biologist, USDA Forest Service, Rocky Mountain Forest and Range Experiment Station, Arizona State University Campus, Tempe, Arizona. Belfit's present address is Headquarters Fort Huachuca, ASH-FE - B, Wildlife Management Section, Fort Huachuca, Arizona.

The most apparent difference between the grazed and exclosed stream segments is the band of small riparian trees and shrubs along the exclosed reach of stream (fig. 2). More than 18% of the exclosed study plots were covered by a mixture of thin-leaf alder (*Alnus tenuifolia*), irrorata willow (*Salix irrorata*), scouler's willow (*Salix scouleriana*), coyote willow (*Salix exigua*), and cliff-rose (*Cowania mexicana*). In contrast, only 0.1% of the grazed study plots were covered by thin-leaf alder and irrorata willow (fig. 3). Herbaceous ground cover was significantly lower on the grazed plots ( $71 \pm 4.5\%$  (S.E.)) than on the ungrazed plots ( $88 \pm 2.4\%$ ) ( $p < 0.05$ , t-test). Moreover, there was significantly more dead and down debris on the ungrazed plots ( $5.3 \pm 2.25\%$ ) than on the grazed plots ( $0.4 \pm 0.31\%$ ) ( $p < 0.05$ , t-test). The presence of organic debris on the exclosure is directly related to the presence of the riparian shrubs, which sift out the material as it moves downstream during floods. Repeated flood accumulations have created debris heaps up to 4 m in diameter and 2 m high. The soil directly below the debris is high in organic content and supports large numbers of terrestrial annelid worms.

#### METHODS

Wandering garter snakes were sampled using a 3-day removal method (Bury 1982) conducted from 8 to 10 July 1983 between 0900 and 1300 hours. Eight plots, 10 by 25 m, were established in the grazed control and the area exclosed in 1972. Each plot was intensively searched daily for a 20-minute period for 3 days (Bury 1982). We alternated both starting points and investigators between days in order to reduce observer bias. Snakes that escaped were not recorded as they could be captured during a later sampling period. All captured snakes were retained in a separate bucket for each plot until the end of the sampling period, and then released on the plot where they were captured.



Figure 1.--Wandering garter snake (*Thamnophis elegans vagrans*).



Figure 2.--Shrubby growth in the exclosure along the Rio de las Vacas.

Active and inactive snakes were observed during the abundance sampling period and from 22 to 24 June and 18 to 19 July 1983. For each snake, we recorded weight ( $\pm 1$  g), stomach contents, the habitat in which it was first observed, and if fleeing, the cover it chose. The taxa in stomach contents were examined after stripping the snakes (Carpenter 1952). Habitat categories were divided into organic (tree base, debris heap, log or board, tree, shrub) and inorganic (rock slope, bedrock or talus, water, rocks) components.

#### RESULTS

Snake abundance and biomass were significantly higher ( $p < 0.05$ , t-test) in the plots exclosed from cattle grazing (table 1). Even though the vegetational complexity of the exclosed area made it much more difficult to sample, five times as many snakes were captured in the exclosed area as in the grazed area.

Stomach analyses showed that earthworms (62%) were by far the most frequently consumed food item, followed by slugs (18%) and fish (9%) (table 2). Although it is possible that the data underestimate the importance of fish on a volumetric basis, most earthworm observations consisted of large boluses. It is clear that worms were the primary food item.

Even though 61% of the snakes were first observed on the open grassy bank (table 3), most were usually less than 1 m from vegetative or structural cover. Snakes were also frequently observed on rocky slopes and in tree bases. Fleeing snakes were often observed heading toward the more structurally diverse streamside habitat. Over 70% of all snakes fled toward tree bases with or without debris or separate debris heaps (fig. 4, table 3).

Table 1.--Numbers and biomass of wandering garter snakes (*Thamnophis elegans*) captured on grazed and ungrazed exclosed plots

Sampling day	Ungrazed		Grazed	
	Number <sup>a</sup>	Biomass <sup>b</sup>	Number	Biomass
1	1.00±0.46	58.13±27.38	0.25±0.25	15.0±15.00
2	0.63±0.42	26.88±19.34	0.25±0.16	12.5± 8.18
3	0.87±0.24	32.00±11.63	0	0
Total	2.50±0.71	117.00±38.04	0.50±0.27	27.5±15.44

<sup>a</sup> Mean number of snakes per 10 x 25 m study plot ± standard error, N = 8.

<sup>b</sup> Mean grams of snakes per study plot ± standard error.

Evening searches of potential overnight cover sites showed that snakes used rocks (48%) and dead vegetation (52%) about equally (table 4). Presence of shed skins suggested that the abundant mammal burrows may also be used as cover sites, but these sites could not be searched adequately.

#### DISCUSSION

*Thamnophis elegans* occupies a wide variety of habitats in different parts of its distribution, and is well known for its tendency to range over relatively large areas (Fitch 1940, 1983, Stebbins 1954, Wright and Wright 1957). However, during the study period at our site, we rarely observed any snakes more than 25 m from the stream's edge. White and Kolb (1974) also found this species mostly limited to stream habitat in a study conducted near Sagehen Creek, California. Although several snakes were observed along small tributaries and marshy

meadows of Rio de las Vacas, none were seen in the adjacent ponderosa pine or mixed conifer habitats, probably because they had a thermally intolerable microclimate (Scott et al. 1982) or provided insufficient food.

Cattle grazing has significantly impacted the riparian habitat along the Rio de las Vacas (fig. 5). There are only a few large, decadent, thin-leaf alder trees on the stream banks and virtually no other shrubby vegetation or riparian development along the grazed portions of the stream. A study of summer grazing of a high elevation willow community in Jackson County, Colorado, similarly showed a riparian stand in poor condition (Cannon and Knopf 1984). Willow shrubs were larger, more decadent and more widely spaced. The width of riparian vegetation was also significantly reduced.

The marked contrast in vegetation emphasizes the importance of the exclosures to this population of snakes. Degradation of the



Figure 3.--Grazed section of the Rio de las Vacas. Notice the lack of living shrubs and the unstable stream banks.



Figure 4.--Small debris heap at the base of a thin-leaf alder (*Alnus tenuifolia*).

Table 2.--Stomach contents of wandering garter snake (*Thamnophis elegans*) along Rio de las Vacas, summer 1983

Stomach contents	Number of stomachs	Percent stomachs
Empty	26	37
Worms	28	39
Slugs	8	11
Fish	4	6
Mammal	3	4
Insect larvae	2	3
Total	71	100

riparian zone by cattle grazing would negatively influence snake populations in the area. Grazing has been shown to negatively affect populations of other reptiles (Berry 1978, Reynolds and Trost 1980). Bury and Busack (1974) ascribed declines in lizard biomass to grazing-caused vegetative degradation. Similarly, Jones (1981) found that lizard populations on heavily grazed mixed riparian scrub and cottonwood-willow vegetative communities were characterized by lower relative abundance and species diversity than those of similar, lightly grazed sites.

The effects of grazing are twofold. First, grazing has a direct impact by affecting the structural characteristics of the habitat. Lack of available cover sites for use by fleeing snakes increases the potential for predation, whereas ungrazed sites, with abundant cover, provide excellent escape and thermal cover. Moreover, the availability of cover sites for inactive snakes may also be a contributing factor; more than half of the overnight cover sites were debris heaps or down logs (table 4). Many of the debris heaps in the ungrazed section were so large (diameter > 2 m) they were not thoroughly searched, and the fact many snakes were still found in them suggests even higher

Table 3.--Habitat used by wandering garter snakes when first observed and when fleeing

Habitat	First observed		Fleeing snakes	
	Number	Percent	Number	Percent
Grassy bank	45	61	7	14
Rocky slope	10	14		
Rock slope with grass	4	5		
Tree base with debris	7	9	25	50
Tree base without debris	4	5	4	8
Debris heap			6	12
Talus or bedrock	1	1		
Water's edge	2	3		
Stream			3	6
Tree	1	1	2	4
Shrub			2	4
Log or board			1	2
Total	74	100	50	100



Figure 5.--Contrast at the fence line between grazed (to the left) and excluded (to the right) stream sections along the Rio de las Vacas.

importance for them. Thermal cover is also necessary for wandering garter snakes to maintain optimum body temperature (Scott et al. 1982). In Larimer County, Colorado, Scott et al. (1982) found that snakes were not seen in the open between 1100 and 1700 h during the warmer months. The lack of thermal cover in the grazed areas probably makes the area intolerable for most of the day.

Second, grazing is known to reduce the abundance and biomass of many invertebrates (Hutchinson and King 1980), the snakes' primary food sources. Both earthworms and slugs were observed only in organic debris heaps during the snakes' activity periods (0800 - 1600 h on clear warm days). Because *Thamnophis elegans* is neither fossorial nor active during rain storms, it is unlikely that it would encounter food items in situations other than within debris heaps or under some other cover. Since organic cover is drastically reduced in the grazed area, difference in food availability is very likely a contributing factor to the observed differences in snake numbers.

Table 4.-- Wandering garter snake overnight cover sites along the Rio de las Vacas, summer 1983

Cover	Number of snakes	Percent
Small rocks ( $\leq 3$ m)	5	22
Large rocks ( $> 3$ m)	6	26
Debris heap	5	22
Down logs	7	30
Total	23	100

In spring and early summer, it is highly unlikely that the snakes are able to maintain energy levels by increasing their use of the abundant fish resources (Rinne 1985). Relatively low water temperature (8-12° C) and the fact that fish are probably harder to catch than worms would seem to discourage aquatic feeding. However, snakes enter the water and were observed foraging for fish once water temperatures reached 15 to 18° C in the late summer.

In conclusion, riparian vegetation and associated organic drift, resulting from the establishment of the fenced exclosures, has greatly increased local populations of Thamnophis elegans. The relatively high canopy cover and accumulated organics provide a favorable microhabitat for preferred food items, an expanded amount of foraging substrate, cover for predator avoidance and a favorable thermal regime.

Considerably more information is needed to adequately describe the effects of cattle grazing on this riparian system. Seasonal and yearly differences in microhabitat and food use as well as home ranges and movement patterns need to be determined to fully understand the importance of riparian structure on high elevation snake populations.

#### LITERATURE CITED

- Arnold, Stevan J., and Richard J. Wassersug. 1978. Differential predation on metamorphic anurans by garter snakes (Thamnophis): social behavior as a possible defense. *Ecology* 59(5):1014-1022.
- Berry, Kristin H. 1978. Livestock grazing and the desert tortoise. *Transactions of North American Wildlife and Natural Resources Conference* 43:505-519.
- Bury, R. Bruce. 1982. Structure and composition of Mohave Desert reptile communities determined with a removal method. In *Herpetological Communities*. USDI Fish and Wildlife Service Wildlife Research Report 13:135-142.
- Bury, R. Bruce, and Stephen D. Busack. 1974. Some effects of off-road vehicles and sheep grazing on lizard populations in the Mohave Desert. *Biological Conservation* 6:179-183.
- Campbell, R. Wayne. 1969. Notes on some foods of the wandering garter snake on Mitlenatch Island, British Columbia. *Syesis* 1:183-187.
- Cannon, Richard W., and Fritz L. Knopf. 1984. Species composition of a willow community relative to seasonal grazing histories in Colorado. *Southwestern Naturalist* 29(2):234-237.
- Carpenter, C. C. 1952. Comparative ecology of the common garter snake (Thamnophis s. sirtalis), the ribbon snake (Thamnophis s. sauritus) and Butler's garter snake (Thamnophis butleri). *Ecological Monographs* 22(4):235-258.
- Drummond, Hugh. 1983. Aquatic foraging in garter snakes: A comparison of specialists and generalists. *Behavior* 86:1-30.
- Drummond, Hugh, and Gordan M. Burghardt. 1983. Geographic variation in the foraging behavior of the garter snake, Thamnophis elegans. *Behavioral Ecology and Sociobiology* 12:43-48.
- Fitch, H. S. 1940. A biogeographical study of the ordinoies ortenkreis of garter snakes (genus Thamnophis). University of California Publications in Zoology 44:1-150.
- Fitch, Henry S. 1983. Thamnophis elegans. *Catalogue of American Amphibians and Reptiles* 320:1-4.
- Fleharty, Eugene D. 1967. Comparative ecology of Thamnophis elegans, T. cyrtopsis; and T. rufipunctatus in New Mexico. *Southwestern Naturalist* 12(3):207-230.
- Gregory, Patrick T., J. Malcolm McCartney, and Donald H. Rivard. 1980. Small mammal predation and prey handling behavior by the garter snake Thamnophis elegans. *Herpetological* 36(1):87-93.
- Hutchinson, K. J., and Kathleen L. King. 1980. The effects of sheep stocking level on invertebrate abundance, biomass and energy utilization in a temperate, south grassland. *Journal of Applied Ecology* 17:369-387.
- Jones, K. Bruce. 1981. Effects of grazing on lizard abundance and diversity in western Arizona. *Southwestern Naturalist* 26(2):107-115.
- Kephart, Donald G. and Stevan J. Arnold. 1982. Garter snake diets in a fluctuating environment: A seven year study. *Ecology* 63(5):1232-1236.
- Ohmart, Robert D., and Bertin W. Anderson. 1982. North American desert riparian ecosystems. p. 433-479. In *Reference Handbook on the Deserts of North America* edited by Gordon L. Bender. Greenwood Press, Westport, Conn.
- Reynolds, Timothy D., and Charles H. Trost. 1980. The response of native vertebrate populations to crested wheatgrass planting and grazing by sheep. *Journal of Range Management* 33(2):122-125.
- Rinne, J. N. 1985. Problems of studying grazing effects on southwestern streams. In *Riparian Ecosystems and Their Management: Reconciling Conflicting Uses*. [Tucson, Ariz., April 16-18, 1985] USDA Forest Service General Technical Report. Rocky Mountain Forest and Range Experiment Station, Fort Collins, Colo. (This proceedings).
- Scott, John R., C. Richard Tracy, and David Pettus. 1982. A biophysical analysis of daily and seasonal utilization of climate space by a montane snake. *Ecology* 63(2):482-494.
- Stebbins, Robert C. 1954. *Amphibians and reptiles of western North America*. McGraw-Hill, New York. 528 p.
- White, Marshall, and James B. Kolb. 1974. A preliminary study of Thamnophis near Sagehen Creek, Calif. *Copeia* 1974(1):126-136.
- Wright, Albert H., and Anna A. Wright. 1957. *Handbook of snakes of the United States and Canada*. Comstock Publication Association, Ithaca, New York. 2 vols. 1105 p.

# Riparian Management of Coastal Pacific Ecosystems<sup>1</sup>

Mark T. Anderson<sup>2</sup>

---

**Abstract.**—The Siskiyou National Forest in Oregon manages riparian areas along the Pacific coast where high value conifers stand near streams bearing salmonid fisheries. Riparian areas are managed by setting objectives which allows for limited timber harvest along with stream protection. The annual timber sale quantity from the Forest is reduced by 13 percent to protect riparian areas and the fishery resource.

---

## INTRODUCTION

Riparian areas on National Forest lands present a sizable management challenge. They are the focus of resource values and uses which often conflict. The President, Congress and other policy makers recognized the importance of riparian areas and have produced numerous Federal and State Laws, Executive Orders and agency direction which must be followed by the land manager. Scientists have studied and written profusely on the importance, values and uniqueness of riparian ecosystems (Johnson and Jones 1977; Karr and Schlosser 1978; Johnson and McCormick 1978). Today scientists are beginning to understand riparian ecosystem structure, function and the complex interactions that occur at this land-water interface (Swanson et. al. 1982)

By comparison, little has been written on the process of managing these physically complex, high value ecosystems. The management problem is compounded by divergent views held by the public and among land managers about the highest and best use of these lands. The objective of this paper is to report on the operational techniques used on the Siskiyou National Forest to lessen conflict and to best manage coastal riparian ecosystems.

## FOREST SETTING

The Siskiyou National Forest totals 1.1 million acres in southwestern Oregon and northern

---

<sup>1</sup>Paper presented at the First North American Riparian Conference on Riparian Ecosystems and their Management: Reconciling Conflicting Uses. April 16-18, 1985, Tucson, Arizona.

<sup>2</sup>Mark T. Anderson is Assistant Watershed Staff, Siskiyou National Forest, USDA Forest Service, Region 6. Grants Pass, Oregon.

California (fig. 1). The Forest is located dominantly in the Klamath Mountain Province but extends into the Coast Range on the north. As shown in figure 2, the Klamath Mountain Province is characterized by rugged, youthful topography with 2000 to 5000 feet of relief (Baldwin 1955). The mountains are comprised of rock formations which are heavily folded, faulted and intruded by ultramafic rocks and other intrusive rocks. Large areas of the Forest are underlain by relatively impervious rock which results in low infiltration rates and high runoff efficiencies (Ramp and Peterson 1979; Dott 1971).



Figure 1.—Vicinity map showing location of Siskiyou National Forest.

Average annual precipitation ranges from 40 inches on the east side to more than 160 inches on the west side of the Forest (Oregon State Extension Service 1982). Unofficial records indicate that annual rainfalls exceeding 200 inches are common in the mountains near the coast.

This steep and relatively impervious bedrock combined with heavy rainfall has produced a landscape replete with streams and rivers.



Drainage densities on the Forest average 3.7 miles of perennial stream per square mile of land surface<sup>3</sup>, exceeding by two-fold the average stream density in the United States (Gregory and Walling 1973).

For this reason, the Siskiyou N. F. manages many acres of near stream riparian habitats—187,000 acres in all. Slightly less than 100,000 acres are within the commercial forest land base where timber is cut. The remaining 87,000 acres are either in wilderness or in areas unsuitable for timber production. Two billion board feet of old-growth Douglas-fir, Port-Orford-cedar, and other high value conifers stand within 100 feet of the streams eligible for harvest.

In contrast to arid areas, a distinct vegetative separation between riparian areas and upland areas is not evident<sup>4</sup>. As a result, there are few floral species which are unique to riparian zones in this area (fig. 2).



Figure 2.—The rugged terrain of the Klamath Mountains in southwestern Oregon.

These same areas are the natural hatcheries of chinook (*Oncorhynchus tshawytscha*) and coho (*Oncorhynchus kisutch*) salmon, steelhead (*Salmo gairdnerii*) and cutthroat trout (*Salmo clarkii*). The Siskiyou boasts one of the largest remaining wild stocks of these fish in the continental United States. The anadromous and resident fisheries on the Forest are valued at several million dollars annually<sup>5</sup>.

<sup>3</sup>Anderson, M. T. 1981. Data on file. See footnote 2 for address.

<sup>4</sup>Atzet, T. 1985. Personal conversation. See footnote 2 for address.

<sup>5</sup>King, D. N. 1985. Numerous Computations of Forest Fish Populations and Values. Unpublished report. See footnote 2 for address.

## RIPARIAN MANAGEMENT

### Historical Perspective

Prior to the 1970's, riparian areas were clearcut and roaded with little regard for the environment, particularly along perennial, nonfish-bearing streams. During this exploitive phase in resource management, the balance of resource uses was tipped heavily to timber. In addition to extracting maximum timber volume, and disturbing the sites, the streams were used as receptacles for logging debris. By the early 1970's, as our concern for the environment grew, our first attempts to protect riparian areas were simply stream cleanout of logging debris. Little attempt was made to protect riparian vegetation initially or to prevent the entry of debris into the stream.

Once these first efforts were accepted, riparian protection progressed rapidly. Soon, aided by direction from the Chief of the Forest Service (1978), standing timber was being left in riparian zones. Defective trees at first, then standing merchantable conifers were left for the protection of stream bank stability, stream temperatures, water quality, fish habitat and wildlife habitat. Managers unwilling to risk any stream disturbance, soon were laying out extensive no harvest buffers. Today riparian areas are managed more objectively, taking or leaving trees based on their contribution to the stated objectives and the ecosystem as a whole. In a period of a decade, riparian management has progressed from exploitation to complete protection and now to whole ecosystem management by setting objectives.

### Forest Planning

The National Forest Planning Act (NFMA) requires the preparation of a comprehensive land management plan for each National Forest in the country. NFMA and its implementing regulations also require that special consideration be given to a minimum of 100 feet each side of all perennial streams. For the purpose of planning, riparian areas are defined in the Siskiyou Plan as 150 feet each side of Class I and II streams<sup>6</sup> and 100 feet each side of Class III streams. By this definition, the Forest has identified 98,053 acres of riparian and wetland areas as distinct management areas with unique timber yield tables and management direction<sup>7</sup>. Several alternative ways of

<sup>6</sup>Streams are classified in USDA Forest Service Region 6 based on beneficial uses (Forest Service Manual 2526, Supp. 42). Class I and II streams are domestic water supplies or support salmonid fish. Class III streams are perennial nonfish-bearing streams.

<sup>7</sup>Process records for Forest planning [n.d.] See footnote 2 for address.

managing riparian areas were evaluated in the plan ranging from clearcut harvest (i.e. treating riparian areas like all other commercial forest land) to complete protection or no harvest. Table 1 presents the allowable timber harvest in riparian areas in terms of a percent of existing basal area by stream class. The effect of these

Table 1.--Allowable Basal Area reductions in riparian areas modeled in the Forest Plan. Prescription (Rx B) is designed to maintain riparian ecosystems and represents current riparian practice. Prescription (Rx C) is designed to improve conditions especially in degraded watersheds.

	Allowable Basal Area Reductions (percent)	
	Rx B	Rx C
Class I & II <sup>1</sup>	30	10
Class III	50	30

<sup>1</sup>See footnote 6.

alternatives on the annual sale quantity (ASQ) is shown in figure 3. The ASQ for the Forest is reduced by 28 MMBF (13 percent) annually when riparian prescription B is applied and an additional 3 MMBF (2 percent) when prescription C is applied. These stated reductions are measured from the alternative which clearcut harvests all riparian areas.

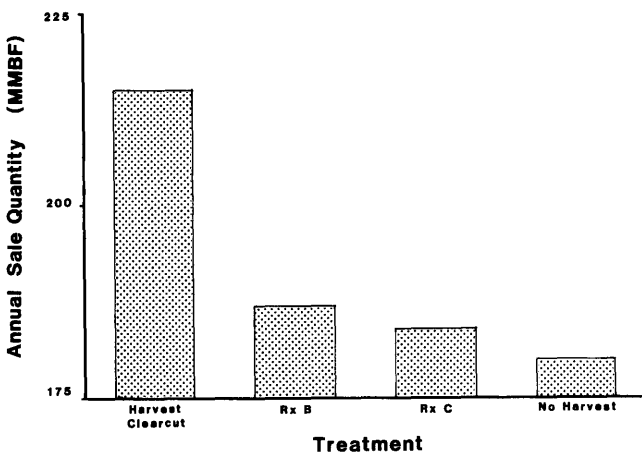

Figure 3.--The effect of several riparian management alternatives on the annual sale quantity from the Siskiyou National Forest in millions of board feet (MMBF). See Table 1 for description of Rx B and Rx C.

### Project Planning and Implementation

Project planning and implementation involves several steps which may require five to ten years from start to finish. The challenge of every

project is to accomplish on the ground, the broad objective of maintaining the integrity of the riparian ecosystem. Present riparian policy on the Siskiyou is guided by the Forest Service Manual (2520.3 Sisk. Supp. 1). The process of riparian management can logically be described by following the Timber Sale Planning Process (Forest Service Manual 2431.2). This process provides for a series of activities leading to control points called "gates." This gate system permits an orderly input of data, analysis and achievement of project work.

### Gate 1

Gate 1 is the position statement where a project is given life. The project area is located and all existing information is pulled together. Stream classes, timber volumes, transportation system needs, downstream values and concerns, enhancement opportunities are all tentatively identified. A key role of the unit manager at this step is the proper selection of resource disciplines and scheduling of tasks. The involvement of the public is also solicited.

### Gate 2

Gate 2 is the environmental analysis. This is the most interactive step of the process and must be done in an interdisciplinary mode. When properly conducted, this interaction of disciplines will produce a superior product. The Siskiyou promotes a project "core" team concept of two or three individuals with other skills brought in as needed. Communication between the unit manager and the interdisciplinary (ID) team leader is essential to ensure the proper use of disciplines, the development of alternatives that are cost-effective and responsive the major issues and concerns, and completion of the project on schedule.

Because each riparian ecosystem is unique, extensive field work by the ID team is necessary to accurately describe the resources and to specifically identify concerns and opportunities (ICOs). The ID team must be mindful of all the complex ecological interactions between vegetation, hillslope processes, climate, nutrient cycles and habitat needs for wildlife and fish. Therefore, a key element in successful riparian management is education and cross-training for the entire workforce. Also, implied here is a close cooperation with research to transfer the latest findings and technological developments.

<sup>8</sup>Stubblefield, T. C. 1984. Integrating Timber Sale Planning With Riparian Area Management. Unpublished report. See footnote 2 for address.

Once all available information is gathered about the ecosystem and the ICOs, the objectives must be set. This step is critical because the objectives will drive the entire remaining process. Any resource value may become the primary objective depending on the inherent characteristics of the ecosystem and the ICOs. For example, wildlife habitat, fish habitat, streambank stability, water temperature or timber production may be the primary objective. Herein lies the point of resolution - an informed discussion that examines the resource and the concerns until the objectives are shared by the ID team, management and the public.

With the objectives set, the management prescription can now be written. The prescription delineates how the objective(s) will be met. For example, specific direction will be included for: the boundaries of the riparian zone, stand management and harvest system, logging method, layout and marking guidelines, fuels disposal, reforestation. Also, a Sale Area Improvement Plan is written which programs any resource enhancement work.

#### Gate 3

The project implementation and layout occurs in Gate 3. Boundaries of the riparian zone are physically located on the ground on the basis of the objectives, terrain features and ecosystem function. The marking crew with the prescription in mind, decides whether each tree, within this newly delineated streamside zone, contributes to the primary objective or not. This technique has been applied on over 150 timber sales over the last four years. The commercial timber volume removed ranges from 0 to 75 percent of the existing stands. Typically, 40 to 50 percent of the commercial volume was removed along perennial, nonfish-bearing streams and 0 to 10 percent along streams that support fish.

#### Gate 4, 5 and 6

Gate 4 involves the preparation of the preliminary contract and advertisement of the timber sale. The timber sale contract is another important instrument for successful riparian management. Protection measures such as directional felling, yarding over the riparian canopy, and control of logging debris must be written into the contract. An example showing the potential of this process when all the factors work together is shown in figure 4. Gates 5 and 6 are the bid opening and award of the timber sale, but have no special significance to riparian management.



Figure 4.--A riparian area along a perennial nonfish-bearing stream after timber harvest.

#### Monitoring

Monitoring is the control point and corrective step in the process. The environmental consequences and the management process are monitored either after project layout or upon project completion. Management field reviews are conducted to check for compliance with Forest and Manual direction, and to compare the riparian objectives and the prescription to the finished product on the ground.

Selected riparian areas are monitored to determine the extent of conifer removal and any physical impacts to the residual vegetation or the stream. Stream water temperatures warmed by direct solar radiation after timber harvest is a common concern on the Forest. A solar charting device is used when needed to monitor shade producing vegetation before and after harvest<sup>10</sup>.

#### CONCLUSION

The Siskiyou National Forest manages nearly 100,000 acres of near stream riparian habitat where highly valued timber and fish production are in conflict. This paper describes the operational process of managing these areas - a subject which rarely appears in the published literature.

<sup>9</sup>Greenup, M. 1981. Silvicultural Prescription for Unit 4 of the Briggs Ridge Timber Sale. Unpublished report. See footnote 2 for address.

<sup>10</sup>Amaranthus, M. P. 1981. Identification of Shade Producing Vegetation: The Solar Chart. Unpublished report. See footnote 2 for address.

Successful riparian management depends upon a well informed workforce that shares a common objectives for each project. The annual sale quantity from the Forest is reduced by about 13 percent to protect riparian areas and fishery resources. Typically, timber harvest will remove 40 to 50 percent of the standing timber volume within our nonfish-bearing riparian areas and 0 to 10 percent along streams that support fish.

#### ACKNOWLEDGEMENTS

Numerous people on the Siskiyou N. F. are responsible for the progress in riparian management in the last five years. I am but one. My thinking on riparian areas and their management has largely been shaped by discussions with Fred Swanson. I borrowed heavily on the knowledge of Ted Stubblefield for the sections on the Timber Sale Planning Process and the gate system. Curtis Day contributed data on timber yields from riparian zones. Robert Ettner and Ed Gross offered numerous helpful suggestions on the construction of the manuscript.

#### LITERATURE CITED

- Baldwin, E. M. 1955. Geology of Oregon, 2nd ed. Univ. Oregon Press, 165p. Eugene, Oregon.
- Dott, R. H. 1971. Geology of the Southwestern Oregon West of the 124th Meridan. State of Oregon, Department of Geology and Mineral Industries, 63p. Portland, Oregon.
- Gregory, K. J. and D. E. Walling. 1973. Drainage Basin Form and Process: A Geomorphological Approach. 458p. John Wiley and Sons, New York, N. Y.
- Johnson, R.R., and D. A. Jones eds. 1977. Importance, Preservation and Management of Riparian Habitat: A Symposium, U.S. Department of Agriculture, Forest Service General Technical Report RM-42, 217p. Fort Collins, Colo.
- Johnson, R. R. and J. F. McCormick. 1978. Strategies for Protection and Management of Floodplain Wetlands and Other Riparian Ecosystems. U.S. Department of Agriculture, Forest Service General Technical Report WO-12, 410p. Washington D.C.
- Karr, J.R., and I. J. Schlosser. 1978. Water Resources and the Landwater Interface. Science 201:229-234.
- McGuire, John R. 1978. A Riparian Policy for Changing Times. USDA Forest Service, Washington Office files, Washington D. C.
- Oregon State University Extension Service. 1982. Average Annual Precipitation 1960-1980, in Southwest Oregon. EM 82:20, Bulletin Room, Oregon State Univ. Corvallis, Oregon.
- Ramp, Len and N. V. Peterson. 1979. Geology and Mineral Resources of Josephine County, Oregon. State of Oregon, Department of Geology and Mineral Industries. 45p. Portland, Oregon.
- Swanson, F. J., S. V. Gregory, J. R. Sedell, and A. G. Campbell. 1982. Land-Water Interactions: The Riparian Zone. In: Edmonds, R. L. ed. Analysis of Coniferous Forest Ecosystems in the Western United States. US/IBP Synthesis Series 14. Hutchinson Ross Publishing Co. Stroudsburg, Pa. pp.267-291.

# Water and People: Common Denominators in Riparian Zones<sup>1</sup>

John C. Buckhouse<sup>2</sup>

---

Abstract.--Water can be allocated according to any number of approaches. People are harder to manage since they work from diverse social, psychological, economic, and aesthetic backgrounds. An approach which brings people together makes the most sense for multiple use management.

---

## INTRODUCTION

I have been involved in grazing research and study of riparian zones for the past ten years. Ramifications of these sorts of investigations are being reported in other sessions at this conference and they form the backbone of the scientific data base through which we pride ourselves as "modern, scientific managers." Certainly, we have learned a great deal concerning actions and interactions associated with natural systems. Because of these research experiences and symposia, such as this one, our society has advanced dramatically in our quest for appropriate scientific management. But after these years I recognize that, as appropriate and necessary as this data bank is, it alone is not enough. It is obvious to me that the social/political/economic element of the mix is missing.

## PLANNING PROCESS

I don't have any magical solutions, but since I recognize that there is something of value for everyone in each riparian system--and that valued thing is often manifested in different forms--I believe we need to take a much more holistic look at these systems.

Perhaps when all is said and done the only meaningful common denominators of riparian zones are WATER and PEOPLE. So, how can management be accomplished in such a way that all needs and values are considered?

I suggest the following:

1. First we must recognize the commonalities of our concerns. I believe most people are concerned with long-range productivity and sustaining values. Let's agree on those points as a beginning step.

2. Next, defining objectives for individual riparian sites is logical. While this could be a tough job, with many pressures and counterpressures, it is necessary--we can't get somewhere unless we know where we want to go!

3. Third, it is necessary to know what the attributes, limitations, potentials, and hazards within any system are. As scientists we have tended to concentrate our efforts here and that is appropriate. For managers, however, this is only one part of the entire scenario.

4. Fourth, a series of alternative management schemes and the ramifications of each needs to be considered.

5. Finally, a plan needs to be written, implemented, and regularly updated to correct deficiencies and/or oversights.

## PLANNING APPROACH

Planning procedures are frequently labeled as awkward, unpleasant, boring and/or unworkable. Yet without them we will continue to spin our wheels, fight unnecessarily and get nowhere--or worse yet, regress.

Two planning aids which may fit into the basic framework and which may have merit in this arena are:

1. A value rating system based upon fees. A common complaint among commodity groups is that recreation does not pay its way. If ALL users were charged a fee, allocation and management of

---

<sup>1</sup>Paper presented at Riparian Ecosystems and Their Management: Reconciling Conflicting Uses. Tucson, AZ, April 16-18, 1985.

<sup>2</sup>Associate Professor, Dept. of Rangeland Resources, Oregon State University, Corvallis, OR.

the resource(s) would probably be simplified. The proceeds of the fees perhaps could be divided up as follows: 25% to the county where the activity occurred for school and road tax relief; 25% to the public land management agency responsible for the land; 25% to the technical agency (i.e. Fish and Wildlife Service) involved with the particular activity; and 25% to handle the administrative costs.

2. Coordinated Resource Management Planning. This is the most effective planning procedure I have encountered. (a) It incorporates all of the land holders and major interest groups. (b) It considers all the multiple resource values in a region. (c) It enjoys legal precedent. (d) It works on a natural boundary, rather than ownership boundary basis. And (e) it deals with those individuals directly involved rather than a cumbersome "all comers" approach.

## CONCLUSION

It is obvious to me that we have entered an era that demands comprehensive natural resource management in general and riparian zone management in particular. Proper management of riparian zones requires comprehensive planning--planning which is action oriented, yet flexible enough to incorporate changes as appropriate, planning which is based upon both ecological principles and mankind's needs. If we couple the scientific knowledge which we are rapidly accumulating with a logical planning framework, the long-term needs of our citizens will be more nearly met and the conflicts of competing uses more equitably settled.

# Integration of Riparian Systems Management Strategies Within the Context of Multiple Use Land Management Programs in Southwestern Wyoming<sup>1</sup>

Donald H. Sweep<sup>2</sup>, J.M. Zilincar<sup>3</sup>,  
Bruce H. Smith<sup>3</sup>, Rodd V. Hardy<sup>3</sup>

---

The extent of multiple use activities on public lands in southwest Wyoming place significant pressure on riparian ecosystems. Our experience indicates that by using an integrated, interdisciplinary management approach, it is possible to maintain existing healthy riparian habitat, and improve or recover lost habitat.

---

## INTRODUCTION

The Rock Springs District of the Bureau of Land Management manages about 6 million acres of public lands in southwest Wyoming.

The District is predominately a sagebrush steppe, a high cold desert ranging from 6,000 feet to 9,500 feet in elevation, with an average precipitation of 8 to 12 inches a year.

District-wide stream habitat surveys have found 1,700 miles of perennial and ephemeral streams on public lands which drain into five major river systems. Watersheds feeding these streams are typically sedimentary basin deposits, predominately sandy in nature. Riparian ecosystems within the district comprise less than 1 percent of the landscape and cross a full spectrum from montane, foothills, desert, and river bottom communities.

Table 1 (Smith 1978) illustrates conditions of 607 stream miles of riparian habitat surveyed in the Rock Springs District.

---

<sup>1</sup>Paper presented at the Riparian Ecosystem Management Conference. (University of Arizona, Tucson, April 16-18, 1985). A slide show accompanying this paper is available from the address below.

<sup>2</sup>Donald H. Sweep is the District Manager, Rock Springs District, Bureau of Land Management, U.S. Department of the Interior, P.O. Box 1869, Rock Springs, Wyoming 82902-1869.

<sup>3</sup>J.M. Zilincar, Public Affairs Officer; Bruce H. Smith, Wildlife Biologist; and Rodd V. Hardy, Range Conservationist. Rock Springs District, Bureau of Land Management, U.S. Department of the Interior, P.O. Box 1869, Rock Springs, Wyoming 82902-1869.

TABLE 1

<u>Riparian Habitat Condition (%)</u>			
<u>Good</u>	<u>Fair</u>	<u>Poor</u>	<u>Virtually None</u>
16	46	32	6

Table 2 (Smith 1978) illustrates the trends of the same 607 stream miles of riparian habitat surveyed in the Rock Springs District.

TABLE 2

<u>Riparian Habitat Trends (%)</u>			
	<u>Good</u>	<u>Fair</u>	<u>Poor</u>
Stable	42	15	94
Declining	58	85	6

While 62 percent of the inventoried riparian systems were found to be in fair to good condition, many of these areas were in a declining trend. Good potential for improvement and possible recovery of lost habitat in the 32 percent of riparian systems in poor condition was identified.

The BLM is specifically directed in its Organic Act, the Federal Land Policy and Management Act (FLPMA 1976), to manage the land it administers "...on the basis of multiple use and sustained yield...".

Multiple use management in the BLM recognizes the interrelationships between scientific disciplines and attempts to make full use of the expertise of each discipline in a coordinated

attempt to meet specific resource management requirements.

The multiple use approach is carried out through the Bureau's planning system. Management proposals are open to public review and based on data obtained from field surveys. After broad decisions are reached, activity plans are developed to address specific locations.

An example of this is our development of a Rock Springs District Riparian Management Policy (Sweep 1984), which outlines management strategies for riparian habitat within all our various programs. Over the past six years, this process has provided the framework for development of numerous riparian projects, studies, special management areas, and broader changes in land management practices.

#### RIPARIAN MANAGEMENT IN THE ROCK SPRINGS DISTRICT

To successfully manage riparian lands, and to restore damaged habitat to potential productivity, a total, ecosystem approach is needed. Depending on the requirements of a specific site, various management techniques may be needed. A total view of the riparian ecosystem will combine specific management efforts into a coordinated approach with appropriate treatments for specific sites, with an overall goal of increased riparian productivity.

For example, a few small riparian monitoring exclosures provided us with specific information that established response or recovery time and site potentials. This information was then used to expand these findings into larger riparian special management units, in which special management techniques, trial grazing systems, or habitat enhancement measures could be tested. To date, these monitoring and special management units number about 60 district-wide, and are providing the basis for our next step into full scale riparian management on a broad basis.

Our Huff Creek and Little Muddy Creek monitoring units help to illustrate stream stabilization and recovery under complete rest from livestock grazing. Along with this habitat recovery, Wyoming Game and Fish Department cooperative monitoring has observed an 182 percent improvement in numbers of fish per mile and 334 percent increase in weight of the rare Bonneville cutthroat trout, a candidate species for threatened status designation.

However, we prefer to manage riparian areas by the use of a rest rotation or deferred grazing system rather than fencing off riparian areas. Fencing off extensive riparian areas is expensive and the cost of annual fence maintenance would be prohibitive.

Some riparian areas that are depleted due to past misuse received intensive management. The key is to first stabilize the riparian area by encouraging shrubs and other vegetation growth to

improve water quality and habitat. Some of these measures include tree plantings, the use of beavers, placement of gabions, and proper design of road crossings. Since introduction at two sites, beavers have improved the ecological condition of some riparian areas. Aspen and other reinforcing material have been trucked into some sites for use by the planted beaver to reinforce their dams. These dams have raised the water table, reestablished a floodplain, and enhanced riparian vegetation recovery.

The White Acorn Allotment is located about 67 miles north of Rock Springs. This allotment was part of an area which, in the late 1800's and early 1900's, was heavily grazed by sheep but today is used by both cattle and sheep. This 48,000 acre allotment was created in 1969. Ten years later an allotment management plan was written after the Big Sandy Grazing EIS was completed. Before the allotment management plan, several exclosures were proposed as grazing mitigation for favorable riparian management.

The most productive forage areas are the subirrigated range sites which are found along perennial streams and in tributary drainages. These subirrigated range sites also make up about four percent of the allotment and occur primarily on private lands.

The overall goal of this AMP is the maintenance or improvement of the rangeland through grazing management. Riparian range sites, because of their great value for many uses, are considered to be of utmost importance for maintenance or improvement in rangeland condition. Six pastures have been created. The three most northern pastures are in a rest rotation grazing system. The three southern pastures have been placed in a deferred rotation grazing system. Use of the riparian range sites has been about 55 to 65 percent of the herbaceous species. Willows and other shrub use has been light and upland sites have been used considerably less. Use of grasses in big sage brush communities within one mile of water during 1982 and 1983 was only 15 to 35 percent.

The permittee is pleased with the resulting improved vegetation and increased livestock productivity.

In the Bone Draw special management unit, consisting of four large riparian exclosures, a riparian habitat was also improved and perennial flows were extended. Stocking assistance from the Wyoming Game and Fish Department and public participation have helped create a nursery area on the Big Sandy River. This has created a nucleus for the development of a seasonal run of rainbow and brown trout up the Big Sandy River, providing a new source of recreation.

Designing and implementing habitat management plans (HMP) to improve riparian habitat has also proved useful in certain areas. The Thomas Fork and East Front HMPs, designed to improve stream habitat and benefit two rare subspecies of



the cutthroat trout, date back to the late 1970's.

The Red Creek Watershed Management Plan was completed in 1982. This plan was designed to reduce siltation, provide fisheries habitat, and stabilize stream banks by promoting riparian vegetation recovery.

Some of the major pressures on riparian habitat in southwest Wyoming result from energy and mineral development. To mitigate these pressures, we are minimizing surface runoff and accelerated erosion effects on drainage hydrology, and crossing streams with small prefab metal bridges or open bottom culverts to prevent accelerated stream flows, gully cutting, and a lowered water table, which would eliminate riparian habitat.

In addition to minimizing adverse impacts, recovery of riparian habitat in poor condition can also be achieved. This can take many forms, including construction of riparian meadow forming structures such as trash catchers or gabions in ephemeral drainages, and the opening of wet meadow riparian sites through the use of pothole developments in order to improve habitat diversity and productivity. Direct planting of lost riparian canopy trees or shrubs is another means being employed in an effort to reestablish not only the condition of riparian habitats, but their structure and function as well.

#### A CONTINUING CHALLENGE

The process we are beginning is, of necessity, a long-term one. Riparian habitat in southwest Wyoming did not decline overnight, but over the course of decades of misuse; and will not fully recover overnight.

The direction of riparian habitat is turning, slowly, from a declining condition to an

improving one.

Riparian areas will continue to be managed for multiple use. Use will be controlled in a way not to impair the riparian ecosystem. Livestock grazing will continue, but not in a manner to cause harm to the vegetation-water-soil riparian resources. Using grazing systems as a way to improve riparian areas will be encouraged instead of using fenced exclosures. A major objective is to work with, and show the benefits of, sound riparian management to livestock operators and other users of the public lands and elicit their cooperation. Emphasis is on a total ecosystem rather than scattered sites, with the goal of returning entire watersheds to productivity. This will continue through the multiple-use planning system, open to public view, that the Bureau uses, and with the interdisciplinary approach we are expanding upon in the Rock Springs District.

#### ACKNOWLEDGMENTS

The authors express their appreciation to the Rock Springs District Resource Area Managers and their staff for their Riparian Management programs which provided the basis for this paper.

#### LITERATURE CITED

- Smith, B. 1978. Completion Report, Rock Springs District Stream Survey, 1975-1977. BLM Rock Springs, Wyoming, U.S. Department of the Interior.
- FLMPA 1976. Public Law 94-579 October 21, 1976, 90 STAT. 2743, Federal Land Policy and Management Act of 1976.
- Sweep, Donald H. 1984. Instruction Memorandum No. WY-04-84-136, Rock Springs District Riparian Management and Monitoring Program. BLM Rock Springs, Wyoming, U.S. Department of the Interior.

# Reclamation of Riparian Zones and Water Law: First in Time — First in Right<sup>1</sup>

Quentin D. Skinner, Michael A. Smith,<sup>2</sup>  
Jerrold L. Dodd, and J. Daniel Rodgers<sup>2</sup>

Theory, research approach and preliminary results of research designed to reclaim a degraded desert steppe stream and riparian zones in Wyoming will be presented. Using trash collectors, willow, and beaver dams to trap sediment, and stabilize bedload for creating additional water storage in riparian zones and their management will be discussed in terms of user rights.

The University of Wyoming is presently involved in and committed to riparian ecosystem research as are many other universities and land management agencies. Some, like Wyoming, are involved with reclaiming degraded streams and riparian zones. Scientists at Wyoming, however, are now asking a hypothetical question that could very well be asked by the chief administrator of Wyoming's water, the State Engineer. This question is: What effect does reclamation of streams and riparian zones have on downstream water regimes and consequently on water rights? Quite frankly the academic community has no answer. The question is legitimate and may need to be answered before multiple users of riparian zones eliminate one another's use privilege based on emotionalism without hydrologic information to support management decisions.

Wyoming's water law is based on the Colorado Doctrine of prior appropriation (Trelease 1979). Other Rocky Mountain states regulate water under this legal doctrine which is based on two basic principles: 1) Water must be put to beneficial use and is not tied to land ownership and 2) priority of use solely determines how water is divided among users when shortages in supply exist. In Wyoming, beneficial use is not defined completely by statute but probably includes two concepts, the nature of use and the non-wasteful application of the use. Wyoming statutes define preferred uses. A preferred use is not an exclusive definition of beneficial use. Use of water for maintenance of aquatic and riparian habitat is not a legally documented preferred use in Wyoming. In addition, many streams are fully appropriated. Water not now appropriated will be junior to existing rights when appropriated. The

legal question of rights and priority for water needed for maintenance of aquatic and riparian habitat has not been answered in Wyoming. The academic community has yet to determine quantity, quality, and timing of water needed to maintain these zones in a desired condition. The academic and land management communities nation-wide have, however, shown why riparian zones are important.

## IMPORTANCE

Riparian zones are used by a wide variety of interest groups (Kauffman and Krueger 1984). Apparent causes for concentration of multiple uses in riparian zones are the vegetation species diversity and productivity, and proximity to open water. High species diversity in the riparian zones is reported by Campbell and Green (1968). The vegetation of this zone stabilizes stream channels by creating a rough surface which reduces stream flow velocity while roots hold bank material together (Li and Shen 1973, and Andrews et al. 1983). Because vegetation traps sediment on banks, water quality is improved (Schumm 1963, Andrews 1982). Lowrance et al. (1985) show how interflow between bank waters and streams in riparian zones further improves water quality. Increase in water quality promotes diverse aquatic habitat and thus improves fisheries (Platts 1981). Riparian habitat and its value to wildlife is well documented (Thomas et al. 1979). Increased edge effect for area occupied (Odum 1978) and vegetation structural diversity compared to surrounding plant communities are often characteristic of riparian zones (Anderson et al. 1983). Both are important for maintaining habitat for a diverse wildlife species composition (Ohmart and Anderson 1978). Likewise, high vegetation production, free flowing water, flat terrain, and shade are cited as reasons livestock use riparian habitat (Kauffman and Krueger 1984). Besides showing importance of riparian zones, the academic and land management communities nation-wide have

<sup>1</sup>Riparian Ecosystems and their Management, Reconciling Conflicting Uses, 1st North American Riparian Conference, Tucson, Arizona, April 16-18, 1985.

<sup>2</sup>Associate Professors of Range Management University of Wyoming, Laramie, Wyoming.

documented user impacts and are studying ways to mitigate them.

#### USER IMPACTS

Users of riparian zones may cause soil compaction, slough off undercut stream banks, and denude vegetation along channels. These actions can increase erosion leading to stream channel widening, downcutting, or both (Meehan and Platts 1978 and Thomas et al. 1979). The results of this erosive action may be loss in: 1) floodplain water tables, 2) floodplain soil moisture, 3) aquatic habitat quality, 4) fisheries, 5) plant vigor, and 6) plant species diversity (Jahn 1978, Platts 1981). Examples of stream degradation and channelization are noted by Meehan and Platts (1978) and Roath and Krueger (1982). Recovery of stream channels, aquatic habitat, fisheries, and riparian vegetation after livestock removal was demonstrated by Platts (1981). These researchers used exclosures to eliminate grazing along stream reaches with different grazing management strategies to hopefully document how best to conserve riparian and aquatic habitat. Little research has been initiated to reclaim streams and riparian zones to promote water storage, control nonpoint source pollution, and answer questions related to water rights and demand for new supplies downstream. This is in contrast to studies designed to evaluate removing riparian vegetation to increase water supplies downstream.

#### INCREASING WATER YIELD BY REDUCING EVAPOTRANSPIRATION

A loss of water through evapotranspiration cannot be denied. Extensive research has been conducted to prove water yield increased when riparian vegetation was removed from flood plains. Large savings of transpired water when salt cedar was removed predicted by Gatewood et al. (1950) and Robinson (1965) were reduced by Culler (1970) and reduced to even less by Horton and Campbell (1974). Bowie and Kam (1968) showed water was saved by removing trees along Cottonwood Creek in western Arizona. Removal of riparian plants to increase water yield has seldom been implemented in the last decade (Graf 1980). This perhaps is because short-term increased yields of water are lost when riparian plants re-invade cleared riparian zones (Horton and Campbell, 1974), high cost to benefit ratios (Graf 1980), other user demands for riparian zones (Campbell 1970), and downstream loss of recoverable water to deep aquifers (Davenport et al. 1982). Certainly conflicts between interests exist as to how to best manage riparian zones. Graf (1980) points out that saving water by reducing transpiration is not as popular as habitat management for other uses. However, managers must reduce flooding when riparian vegetation reduces stream channel conveyance of flow to and through downstream areas. Conversely, if developed riparian zones cause flooding, why not use this phenomenon to repair degraded stream channels, store ground water, control non-point source pollution and increase

production for grazing, wildlife habitat, and recreation.

#### RECLAMATION OF DEGRADED STREAMS AND RIPARIAN ZONES

Invading riparian plants stabilize stream bars, islands, and flood-plains. Often bars become islands and channels around islands are closed to form floodplains bordering one channel. This occurs when flushing flows are unable to remove established vegetation and overbank flooding deposits sediment to further advance channel filling. This normally occurs in low gradient rather than steep stream reaches. When stream flow regime is in equilibrium with channel size and bank resistivity, developed riparian zones may dictate geomorphological character of the stream system (Leopold et al. 1964, Graf 1978, Heede, 1981). This process may begin in a wide, degraded stream channel when surface flow decreases. Low flow across low gradient channel bottoms meander thereby increasing stream sinuosity and length. Permanent aggradation occurs when sediment deposits from flow and is stabilized by vegetation. Andrews (1982) shows aggradation occurs first during overbank flooding and bedload accumulates during lower flows. Accumulated bedload may persist until the channel narrows to meet the annual flow regime. Narrowing of the channel causes increased flow velocity and accumulated bedload is then transported downstream causing the channel to deepen. Andrews (1982) further points out that although a stream maintains an average width and depth in equilibrium with the flow regime, it will move laterally from year to year thus fitting Leopold and Langbein's (1966) description of meandering streams. The presence of undercut banks along stable streams are evidence of lateral movement of meanders.

Reclaiming degraded streams to support mature riparian zones depends on deposition and stabilization of deposited sediment by vegetation. Stream channel transmission loss of water downstream during a high flow event to surrounding alluvium occurs as shown by Lane et al. (1970). Loss in flow downstream should cause aggradation of sediment. Glymph and Holton (1969) show loss of stream flow from any one event in semi-arid regions should be maximum near the mouth of a drainage basin or in larger basins if channel transmission loss occurs. Locations of manipulative practices to reclaim degraded streams based on loss of flow and aggradation of sediment should have maximized water travel time. Travel time is maximum in low gradient meandering reaches often found farther downstream.

Damming by instream flow structures, like check dams or trash collectors, and biological damming by beaver or constrictive channel dams caused by encroaching banks and riparian zones cause: 1) reduced flow velocity, 2) stable bedload and, 3) storage of water in banks proximal to the dam. Heede (1978 and 1982) discusses reclamation of gullies using check

dams to raise a local base level of ephemeral stream reaches to decrease gradient slope upstream. The lower gradient reduces sediment transport. Following Heede's 1978 and 1982 research, dams should be placed downstream just above a tributary junction. To achieve greater restoration of riparian habitat however, the dam should also be located on a stream reach having a low gradient where meandering occurs and a stable floodplain exists. The dam should then cause bank deposition of sediment and maximum filling within the upstream drainage network. Established riparian vegetation and narrowing of the channel may then eventually cause water spreading over banks during flood producing events (Graf 1980).

Whether reclaiming degraded streams and riparian zones will affect downstream water rights is unknown. Monitoring of associated hydrologic responses when manipulation of riparian ecosystems occurs is needed. Water has been left out of most riparian research efforts. It could, however, be hypothesized that:

1. Increased ground water storage can be accomplished through improved riparian zone management. Storage of water in semi-arid regions of the world during periods of high flow has been a major justification for constructing dams. Storage behind dams allow prolonged conveyance of water during periods of need to various user groups. Lack of adequate sites for dams and present economic constraints now limit construction of new water storage facilities. Consequently water planners should now look at initiating alternative ways to store water. One alternative is to explore storage of water in floodplain and adjoining aquifers of streams tributary to those dammed.

Riparian zones and flood plain aquifer storage should reflect stream channel condition. Degraded stream channels in poor condition from downcutting or increase in width may not cause increased bank storage during high flow events when excess water from drainage basins are conveyed downstream. Riparian vegetation may be limited or absent when stream channels are in poor condition. Encroachment of riparian vegetation into degraded channels should cause constrictions in the channel similar to a dam with a spillway equal to the average yearly bank full stage of the flow regime. This natural damming should increase storage of water during flood events upstream and across aquifer-type alluvium in valley floors. Stored water would then be available later to meet later flow requirements for downstream uses.

2. Improvement of riparian zones can create desired aquatic habitat during decreased flow and still store water. Flow regime is critical for maintaining diversity of aquatic and riparian habitat. Good riparian zone management may promote flushing flows even when less water or a steady state flow regime is provided downstream. For instance, if water planners choose to release less water from reservoir storage or from diversions to downstream for extended periods of time

sediment should cause channel bank encroachment and vegetation stabilized banks to meet the new flow regime. Sediment during low flow may cover original channel substrate and decrease aquatic diversity until dynamic equilibrium between flow regime and encroaching channel banks occur. Then decreased channel width will increase flow velocity and move bed load downstream, creating deeper channels. The final product of this use of flow regime to promote good riparian zone management could be increased riparian zone area, increased bank water storage, and a narrower stream channel with improved aquatic habitat. Recharge of water to flood plains could occur if discharge from reservoir storage or diversions are increased past bank full stage still using the original reduced supply of water to downstream while allocation follows a natural flow regime.

The alternative to using a limited supply of water to create improved aquatic and riparian habitat is to determine how much and when an increase in reservoir or diversion release downstream is needed to flush sediment and vegetation out of existing channels. During future periods of short supply or increased demand from legal users of water appropriate flushing flows to meet aquatic and riparian zone habitat needs may not be possible. It will, therefore, be imperative to understand how to create riparian zones to meet flow regimes and maintain desired aquatic conditions.

3. Improvement of degraded riparian zones through ground storage of water may help control non-point source pollution. Improving water quality is one way of extending water supplies. Entrapped sediment and nutrient loading within reservoirs, and increased salt content downstream because of water moving through banks to streams have long been of national interest. Reclaiming degraded streams tributary to major river systems using improved riparian zones should help reduce non-point source pollution in a cost effective manner. Using vegetation to trap sediment during high flow events can be effective when economics limit mechanical and structural treatment of streams and riparian zones. Water moving through mature riparian zones as bank storage, in stream flow across and through meander flood plains, and bed load behind instream flow structures is subjected to possible tertiary treatment for removing nutrients.

The riparian zone may well be the drainage basin's one habitat where anaerobic bacterial activity is maximized. This condition is created when soil air is replaced by water. Nutrients capable of being eliminated by anaerobic bacteria to a gaseous by-product could be reduced in well managed riparian zones before polluting stream flow. Certainly the high potential plant production of this zone favors assimilation and retention of nutrients. Salt load downstream could be increased because of leaching by repeat flooding and high watertables but salt in trapped sediment might be less mobile than in sediment flowing downstream.

Demand for aquatic habitat conservation, reservoirs and inter-basin diversions, channelization to control floods, peak and minimum flow from storage to meet demand for hydroelectric power, and need for additional water for fossil energy development are several reasons resource managers must emphasize this limited but valuable habitat type. Because of multiple demand for existing water supporting riparian zones, it is imperative resource managers know how to reclaim degraded streams and best manage created or existing wetland zones to meet future needs. During the 1970's impacts to riparian zones and streams by multiple users were documented. During the 1980's, we should address how to perpetuate existing resources, improve degraded streams and riparian zones and develop best management strategies to mitigate present and future environmental impacts.

4. Geologic variability and geomorphological characteristics of drainage patterns can help predict water storage capacity for streams being reclaimed for riparian zone values. Geologic characteristics of streams provide historical background for criteria needed to plan actions to answer water resource questions associated with drainage basins. Planners have to make decisions which meet economic and legal constraints when degraded streams are reclaimed for water storage and improved riparian and aquatic habitat. Geomorphology of streams should be used to select best sites for reclaiming a cold desert steppe stream. Geomorphological criteria can be used to select sites in any drainage basin or along a stream draining one basin. For example, valley cross-section profile of recent and ancient geologic alluvium provides information on surface and ground water storage potential. Surface profile may be conducive to large area flooding above and below ground but if ancient alluvium deposits are not aquifers then water storage will be confined to new alluvium. The difference between the alluvium types would predict basin storage of water after riparian zone improvement practices.

5. Reclamation of degraded streams and riparian zones to store water can increase forage and species diversity of plants and animals. Food products for increased human populations is an ever-increasing world-wide problem. It will be even more important in the future to maintain riparian zones in a condition promoting maximum water storage and forage production. Forage should be distributed in herbaceous, shrub, and tree life forms. Planned plant diversity will provide habitat for wildlife and livestock grazing, maintain stream channel stability and promote aquatic habitat for fish. All provide food for future needs and through innovative management, maximizes use of land and water resources.

Assuming reclamation of degraded streams and riparian zones is important, the University of Wyoming Range Management Department, Wyoming Water Research Center, Bureau of Land Management, Wyoming Department of Environmental Quality, and Wyoming ranchers have initiated two

riparian research programs. Goals for this effort are:

- 1) Store water for prolonged release downstream and increase vegetation yield, 2) Control nonpoint source pollution, 3) Develop strategies for reclaiming degraded streams and riparian zones, and 4) Advance the state-of-art for management of range ecosystems.

The example illustrated for this paper is "Reclamation of a Cold Desert Steppe Stream Using Instream Flow Structures, Vegetation, and Beaver." Examples of pertinent questions to be answered from this research are:

1. How does water storage differ between degraded, natural, and improved riparian zones of a high desert steppe stream?
2. Do different stream reaches have different water storage capabilities along an improved cold desert steppe stream?
3. Do improved riparian zones change a flow regime and, if so, is there a prolonged release of water for downstream users?
4. What are the hydrologic responses associated with riparian zone improvement practices of a cold desert steppe stream such as: damming by beaver and instream flow structures, willow and grass establishment, brush control (burning, spraying) and fertilization?
5. Can riparian zone improvement practices initiated on cold desert steppe streams reduce nonpoint source pollution downstream?
6. What mechanisms do improved riparian zones of a cold desert steppe stream provide for control and abatement of nonpoint source pollution?
7. What are the hydrologic responses associated with grazing of improved riparian zones of a cold desert steppe stream by livestock and wildlife?
8. What are the economic costs and benefits of improving degraded riparian zones of a cold desert steppe stream?

#### REFERENCES

- Anderson, B.W., R.D. Ohmart, and J. Rice. 1983. Avian and vegetative community structure and their seasonal relationships in the lower Colorado River Valley. *Condor* 85:392-405.
- Andrews, E.D. 1982. Bank stability and channel width adjustments, East Fork River, Wyoming. *Water Resources Research*, 18:4:1184-1192.
- Bowie, J.E. and W. Kam. 1968. Use of water by riparian vegetation. Cottonwood Wash, Arizona. *Water Supply Paper* 1858. U.S. Geol. Surv., Washington, D.C. 62 pp.

- Campbell, C.J. and W. Green. 1968. Perpetual succession of stream-channel vegetation in semiarid region. *J. Ariz. Acad. of Sci.* p. 86-98.
- Culler, R.C. 1970. Water conservation by removal of phreatophytes. *Am. Geophys. Union Trans.* 51:684-689.
- Davenport, D.C. P.E. Martin, and R.M. Hagen. 1982. Evapotranspiration from riparian vegetation: Water relations and irrecoverable losses for saltcedar. *J. Soil and Water Cons.* 37:4:233-236.
- Gatewood, J.S., J.W. Robinson, B.R. Colby, T.D. Hem, and L.C. Halpenny. 1950. Use of water by bottom-land vegetation in Lower Safford Valley, Arizona. *Water Supply Paper 1103*, U.S. Geol. Survey, Washington, D.C. 210 pp.
- Glymph, L.M. and H.N. Holton. 1969. Land treatment in agriculture watershed hydrology research. In: *Effects of watershed changes on streamflow*, *Water Resources Symp. No. 2*, Univ. Texas Press. Austin. p. 44-68.
- Graf, W.L. 1978. Fluvial adjustments to the spread of tamarisk in the Colorado Plateau Region. *Geol. Soc. of Amer. Bull.* 89:1491-1501.
- Graf, W.L. 1980. Riparian management—a flood control perspective. *J. Soil and Water Cons.* 35:158-161.
- Heede, B.H. 1978. Designing gully control systems for eroding watersheds. *Environ. Manage.* 2(6):509-522.
- Heede, B.H. 1981. Dynamics of selected mountain streams in Western United States of America. *Z. Geomorph. N. F.* 25:1:17-32.
- Heede, B.H. 1982. Gully control: Determining treatment priorities for gullies—a network. *Environ. Manage.* 6(5):441-451.
- Horton, J.S. And C.J. Campbell. 1974. Management of phreatophyte and riparian vegetation for maximum multiple use values. *Res. Paper RM-117*. U.S. Forest Serv. Fort Collins, CO. 23 pp.
- Jahn, L.R. 1978. Values of riparian habitat to natural ecosystems. In: *Proc., Strategies for Protection and Management of Floodplain Wetlands and Other Riparian Ecosystems*. USDA GTR-WO-12:157-160.
- Kauffman, J.B. and W.C. Krueger. 1984. Livestock impacts on Riparian ecosystems and streamside management implications.. A review. *J. Range Manage.* 37:5:430-438.
- Lane, L.J., M.H. Diskin, and K.G. Renard. 1970. Input-output relationships for an ephemeral stream channel system. *J. Hydrology* 13:22-40.
- Leopold, L.B. and W.B. Langbein. 1966. River meanders. The physics of everyday phenomena, *Sci. Am.* 79:28-38.
- Leopold, L.B., M.G. Wolman, and J.P. Miller. 1964. *Fluvial Processes in Geomorphology*. W.H. Freeman and Company, San Francisco.
- Li, Ryh-Ming, and H.W. Shen. 1973. Effect of tall vegetation and flow sediment. *J. Hydraulics D, ASCE, Vol. 9, No. HY5, Proc. Paper* 9748.
- Lowrance, R., R. Leonard, and J. Sheridan. 1985. Managing riparian ecosystems to control nonpoint pollution. *J. Soil and Water Cons.* 40:1:87-91.
- Meehan, W.R. and W.S. Platts. 1978. Livestock grazing and the aquatic environment. *J. Soils Water Cons.* 33:5:274-278.
- Odum, E.P. 1978. Opening address: Ecological importance of the riparian zone. In: *Proc. Strategies for Protection and Management of Floodplain Wetlands and Other Riparian Ecosystems*. USDA Forest Serv. GTR-WO-12:2-4.
- Ohmart, R.D. and B.W. Anderson. 1978. Wildlife use values of wetlands in the arid southwestern United States. *Proc. National Symposium on Wetlands*. American Water Resources Association, 278-295.
- Platts, W.S. 1981. Effects of sheep grazing on a riparian/stream environment. *USDA For. Serv. Res. Note Int.* 0-307. 6 pp.
- Roath, L.R. and W.C. Krueger. 1982. Cattle grazing influence on a mountain riparian zone. *J. Range Manage.* 35:1:100-103.
- Robinson, T.W. 1965. Introduction, spread, and areal extent of saltcedar (*Tamarix*) in the western states. *Prof. Paper 491-A*. U.S. Geol. Surv., Washington, D.C.
- Schumm, S.A. 1963. Sinuosity of alluvial rivers on the great plains. *Geological Soc. of Amer. Bul.* 74:1089-1100.
- Thomas, J.W. C. Maser, and J.E. Rodiek. 1979. *Wildlife habitats in managed rangelands - The Great Basin of southeastern Oregon. Riparian Zones*. USDA Forest Serv. Gen. Tech. Rep. PNW-80.
- Turner, R.M. 1974. Quantitative and historical evidence of vegetation changes along the upper Gila River, Arizona. *Prof. Paper 655-H*, Geol. Surv., Washington, D.C. 20 pp.

# Impacts of Oil and Gas Development on Riparian Zones in the Overthrust Belt: The Role of Industrial Siting<sup>1</sup>

Robert G. Elder<sup>2</sup>      Richard C. Moore<sup>2</sup>

-----  
Abstract.--As oil and gas development in the Overthrust Belt of Wyoming expands, the need to minimize impacts to riparian systems becomes increasingly important. However, regulatory control is sometimes ineffectual. Because of its broad powers, the Industrial Siting process can play a key role in mitigating environmental impacts that are otherwise unregulated.  
-----

## INTRODUCTION

Oil and gas production in recent years has continued to rise dramatically in the Overthrust Belt (Wyoming Oil and Gas Conservation Commission 1982). This belt is one of nine geologically distinct salients that exist within the Cordilleran Fold, a much larger tectonic province which extends from Alaska to Mexico (VerPloeg and DeBruin 1982). The Overthrust Belt, or the Idaho-Wyoming-Utah Salient, is an arcuate region of folds and faults extending 200 miles from the Snake River Plain in Idaho to the Uinta Uplift in Utah. It is about 100 miles wide with its convexity protruding into Wyoming.

The use of improved exploration and drilling technologies has opened areas heretofore immune to development, areas that are not only mountainous, but in many cases very remote, pristine, and contain important riparian resources. These riparian resources exist within a region that is nationally known for its abundance and diversity of wildlife and its excellent fisheries. This paper discusses two aspects of the rapid development of oil and gas reserves in western Wyoming: 1) impacts on riparian zones, and 2) the existing governmental regulatory framework as it relates to those impacts.

## IMPACTS ON RIPARIAN ZONES

Impacts on riparian zones occur from all aspects of oil and gas development, including

roads, and pipelines. Typical impacts are caused by direct disturbances, accelerated erosion, reserve pit failure, aerosols, and blow-outs. Facilities obviously impact riparian zones directly if they are constructed within flood plains or stream bottoms. However, the long-term consequences of sedimentation on streams and riparian zones can be more serious. These include changes in channel morphology, loss of stream bank stability, downcutting, drawdowns in alluvial groundwater, and deterioration of riparian habitat (Skinner and Stone 1983). These processes, particularly in arid areas such as southwestern Wyoming, result in positive feedback mechanisms which are self-perpetuating and difficult to control except by expensive reclamation techniques. And whereas reclamation is certainly an important mitigation, it should not be used as a substitute for sound construction practices and effective planning.

Nevertheless, we often find that more emphasis is placed on reclamation than on avoiding needless damage at the outset. For example, one stabilizing influence in the headwaters of many drainages is the presence of beaver. Beaver ponds act as sediment traps, reduce discharge velocities, and attenuate hydrographic amplitudes, all of which stabilize erosional processes. However, in many cases, little effort is applied toward preserving these systems of naturally occurring controls.

Less frequent impacts include the effects of reserve pit failure, aerosols, and blow-outs. The possibility of reserve pit failure necessitates the careful planning and design of wellpads, particularly in the Overthrust Belt where pads are usually placed on steep slopes. Pit failure not only causes direct physical damage and leads to accelerated erosion, but introduces toxic chemicals to drainages. Aerosols lost from reserve pits also contain toxic materials. Finally, the presence of high construction of plant sites, wellpads, access

---

<sup>1</sup>Paper presented at the First North American Riparian Conference, Riparian Ecosystems and Their Management: Reconciling Conflicting Uses, April 16-18, 1985, Tucson, Arizona.

<sup>2</sup>Robert Elder is Environmental Specialist and Richard Moore is Director, Office of Industrial Siting Administration, State of Wyoming, Cheyenne.

concentrations of salinity and, of course, oil can create serious environmental impacts after blow-outs.

In addition to localized impacts, cumulative impacts are becoming obvious as more industry moves into southwestern Wyoming. A flight over the region impresses one with the large amounts of surface disturbance associated with roads, pipelines, wellpads, seismic lines, and plant sites. Presently, there are nine major fields in the Wyoming portion of the Overthrust Belt and at least eight big processing plants either planned or in operation. When appurtenant components, smaller plants, and small wellfield operators are included, the overall impacts to one of the Nation's most important wildlife and fishery resources becomes extremely significant.

It is, therefore, imperative that development proceed in an orderly way, that mitigations and safeguards to protect riparian zones are implemented, and that appropriate regulatory authority exists. Many examples of problems and concerns cited so far have occurred since the passage of most of our major environmental statutes. Why, at a time when regulation is viewed by some as duplicative, unneeded, excessively cumbersome, and expensive, do problems still exist? Do they exist because of insufficient regulatory authority or ineffectiveness within the existing system? We address these questions in the following sections.

#### REGULATORY AUTHORITY

In Wyoming, regulatory control of environmental impacts associated with the oil and gas industry exists solely with the federal and state governments. Counties and communities may have zoning and land use plans, but state law prohibits the use of such plans to impede mineral extraction.

Federal lands in the Overthrust Belt are administered almost exclusively by the Forest Service and the Bureau of Land Management (BLM). However, the BLM administers federal onshore mineral rights and, thus, maintains at least some control over all surface disturbances on federal lands caused by mineral extraction.

Both the Forest Service and the BLM use the same "best management practices" (BMPs) to control surface disturbances associated with oil and gas exploration and production (U.S. Departments of Interior and Agriculture 1978). Additionally, the federal land management agencies require site-specific mitigations to insure that particularly sensitive areas are not unnecessarily damaged. Although the permitting system employed by the federal government is becoming very effective in ameliorating impacts to riparian zones, several shortcomings are still apparent: 1) There is some question as to whether lease development can be denied once the lease has been issued.

2) Compliance assurance is difficult with the large number of operations occurring within federal lands. 3) Development sequencing often occurs through the permitting of one component at a time, with little regard for overall project impacts. Finally, it must be remembered that federal land management agencies administer only national lands and that many projects in the Overthrust Belt are on other lands. Sometimes facilities cross boundaries of different ownership. In these cases, applying uniform standards to all project components is difficult.

Other federal agencies have limited jurisdiction over oil and gas development. The Army Corps of Engineers oversees Section 404 of the Clean Water Act. However, regulatory review is limited to waters with a mean annual flow of 5 cfs or more, which eliminates most lower-order streams in the Overthrust Belt from the individual permitting requirements of Section 404.

The Environmental Protection Agency (EPA) implements water quality standards in Wyoming through the Wyoming Department of Environmental Quality (DEQ). Nonpoint discharge is a major factor in damage to riparian zones but the 208 program, authorized by the Clean Water Act to address nonpoint pollution, is ineffective in this case. Although water quality management plans are in effect in Wyoming, none address sediment directly nor establish BMPs for the oil and gas industry.

Wyoming state agencies governing environmental aspects of oil and gas permitting requirements include the Oil and Gas Conservation Commission (OGCC), DEQ, and the Industrial Siting Administration (ISA). The ISA, its environmental regulatory authority, and its relationship to other permitting agencies, is the main focus of this paper. Accordingly, it is discussed separately in the following section. The functions of OGCC and DEQ are summarized below.

The OGCC has responsibility for all wellhead activities, including drilling, deepening, and plugging. As the name implies, the main purpose of the OGCC is the conservation of the resource and the management of the State's vested interests. Although the OGCC has environmental authority, particularly in the wellfield, limited staffing and the legislative intent of the Oil and Gas Act to develop the resource probably will limit its role as an environmental regulator. Furthermore, oil and gas production in southwestern Wyoming is far more complicated than simply the development of wellfields. Large processing plants, major pipelines, and other facilities are becoming increasingly common.

The Wyoming DEQ is the state's counterpart to EPA. The DEQ has minimum authority over riparian zones impacted by oil and gas development until a problem exists. The existence of state-wide water quality standards enables corrective action to be enforced, but the lack of a standard for suspended solids



makes prosecution of sediment-related offenses very difficult. Furthermore, violations of other water quality standards may result in non-compliance proceedings but, by then, irrevocable damage may have occurred.

It is apparent that the environmental regulatory process can be not only complex, but ineffective in addressing some impacts. The difficulty arises in trying to develop an efficient regulatory system in which all environmental concerns are addressed but which, at the same time, minimizes jurisdictional overlap. In order to avoid overlap, most agencies are delegated with very specific authority. This means that during permit proceedings, gaps in authority are encountered that, in some cases, lead to a lack of jurisdiction over industries, facets of industries, or certain lands. For example, gas pipelines crossing the "checkerboard" pattern of alternating sections of public domain and private land in southwestern Wyoming can create administrative imbroglios.

The kinds of environmental impacts and permitting problems discussed so far indicate the need for a broad, generalized regulatory authority capable of incorporating innovation, site-specific analyses, and comprehensive planning into mitigation requirements. This is the premise behind the many industrial siting laws that now exist in the United States. The Wyoming Industrial Development Information and Siting Act was passed in 1975 to this end.

#### INDUSTRIAL SITING ACT

The coverage of the Industrial Siting Act extends to all types of industrial development occurring within Wyoming. Specific coverage is provided for energy generating and conversion plants.

The Act also provides for inclusion of any other industrial facility with an estimated construction cost of at least \$50 million in 1975 dollars. This provision includes any major industrial facility not specifically covered above. As a result of the oil and gas development occurring in southwestern Wyoming, the 1981 Legislature amended the Act to specifically include any gas processing plant with an estimated construction cost which exceeds the jurisdictional threshold amount.

Prior to commencing construction on any facility defined as an industrial facility, an Industrial Siting Permit must be obtained from a seven-member council appointed by the Governor. To receive a permit, the applicant prepares a comprehensive evaluation of the environmental and socioeconomic considerations of siting the facility. This includes an assessment of the baseline condition, a complete description of the facility, an estimate of the impacts associated with construction and operation of the facility, and proposed plans to mitigate identified impacts.

The staff of the Administration then

prepares a comprehensive independent analysis of the facility. As a result of this analysis, the staff recommends permit conditions which should be required. The permit may be conditioned upon the applicant providing appropriate mitigation to resolve these, and any other, concerns that are identified during the process.

Although the Council has broad and comprehensive jurisdiction over all aspects of an industrial facility, there is a very fine line which has to be followed to ensure that all environmental issues are adequately addressed without resulting in overlapping jurisdiction with other regulatory agencies with specific authorities. The Act has been described as a "safety net" provided to ensure that problems which cannot be adequately resolved by other agencies can still be addressed. Before granting a permit, the Council must be able to find that the proposed facility complies with all applicable law; that the facility will not pose a threat of serious injury to the environment or the social and economic conditions of the inhabitants in the area; and that the facility will not substantially impair the health, safety or welfare of the inhabitants. This broad authority vested in the Council has enabled it to resolve problems caused by development on a case-by-case basis, seeking the most appropriate solutions under the circumstances surrounding each project.

Coordination with agencies of the federal government is not mandated. However, it has been recognized that there is the potential for duplication of effort between State and federal permitting requirements, with the possibility of conflicting requirements. The Administration cooperates with both the Forest Service and the BLM to eliminate duplication in the permitting process.

Likewise, a provision does not exist for the coordination of permit processing with other state agencies or for joint hearings. However, other regulatory agencies are considered advisory to the Council, and may provide recommendations to the Council. These agencies also benefit in their review of their own permit applications from the information developed as a result of the siting process.

The Council has the authority to preempt other state agencies, except the Public Service Commission and the Department of Environmental Quality. When regulations were adopted, however, the Council determined that this authority was not specific enough to allow for the preemption of other permits required by statute. Therefore, in practice, the Council does not preempt other state agencies.

The Process provides for a maximum of public participation. All affected units of government, persons residing in the area, and nonprofit citizens' groups may become parties to a permit proceeding. All permit applications are subject to an adjudicatory-style hearing before the

Council. All testimony is subject to cross examination by other parties. Informal, written comments may also be received by the Council for their consideration.

#### PROBLEM AREAS

One of the major difficulties in the establishment of the siting process has revolved around two questions of jurisdiction. The first involves the specific exemption of certain facilities. The second involves the exemption of any facilities that were either constructed before passage of the Act in 1975 or before the 1981 amendments expanding jurisdiction to oil and gas processing plants, or that do not meet the jurisdictional threshold criterion in construction costs. These two questions are discussed separately.

A major weakness of the program has been the lack of jurisdiction over certain facilities, including oil and gas pipelines, natural gas pipelines, and oil and gas producing and drilling facilities. However, the Act requires the Council to consider cumulative effects within the area of site influence of a project. This has created uncertainty in how to regulate consolidated projects consisting of both gas processing plants, which are clearly within the Council's jurisdiction, and wellfields and pipelines which by themselves would be exempt, but which contribute to the cumulative effects in the area of site influence. At this time, the Council has not clearly resolved this issue.

The second question of jurisdiction is related to the effective date of the Act and the threshold criterion. Virtually all areas in Wyoming which are experiencing rapid growth are experiencing that growth as a result of the cumulative development of many projects. Since the Siting Council cannot require one company to mitigate the impacts of another company's project, the lack of jurisdiction over all projects in our rapidly growing areas has hindered development of comprehensive mitigation programs. This is most evident in the southwestern part of the State where oil and gas development caused significant impacts before the Act was amended to include gas processing plants. The exemption of wellfields and pipelines, however, has continued to hinder the effectiveness of the Council in dealing with all the effects of the oil and gas development.

Other problems that may not be as significant as the question of jurisdiction but which, nevertheless, surface occasionally include interstate projects and private ownership of affected lands. The first of these has occurred only once and involved a wellfield in Utah serviced by a processing plant in Wyoming. The private ownership issue is one that has created some conflict but has always been resolved through cooperation between all parties involved. One case involved a company's excellent reclamation plan which was almost destroyed by the landowner's insistence that

livestock be allowed to roam freely over areas being revegetated.

Most of the permitting within the last several years has related to the development of oil and gas in the Overthrust Belt. Since regulation of the oil and gas industry is only a recent development in the Council's history, both the industry and the Council have been going through a "feeling out" process with respect to the Act. Because of the jurisdictional problems with exempt facilities described previously, much of the attention in recent proceedings has focused on the extent of the Council's authority, rather than on the solutions to complex, cumulative impacts. As the Council gains more experience with oil and gas projects, and the industry learns what is expected from the Siting Process, these problems should become less acute.

#### ACCOMPLISHMENTS

The Wyoming Industrial Siting Process is generally regarded as having been extremely successful. Since passage of the Act, numerous permits have been issued for a wide variety of types of facilities. All permits have been processed without any significant delay to the projects, yet have resulted in the issuance of permits which have required comprehensive mitigation programs.

In spite of the aforementioned problems, the Industrial Siting Process has often resulted in significant mitigations for impacted riparian areas that no other regulatory review would have required. These accomplishments have generally fallen into several broad categories including siting of facilities, monitoring programs, implementation of site-specific standards, curtailment of channel alterations, and improved design and construction techniques.

Because processing plants must logically be located within reasonable proximity to the resource, the locational siting of major facilities is somewhat restricted. However, in several cases, the Siting Process has resulted in the relocation of individual project components and, thus, reduced potential impacts to riparian zones. For example, requirements to move proposed pipelines and access roads out of sensitive drainages have been incorporated into the review process. Another example was the relocation of a water intake structure from an environmentally sensitive riparian zone to an area of less critical concern. The final location not only eliminated unnecessary impact but was less expensive to the company. This project also was under BLM review, but through interagency cooperation and communication, ends were achieved that were acceptable to all parties.

Most permits issued by the Council contain provisions for monitoring. Monitoring of impacts on riparian zones have included benthic invertebrate studies, water quality monitoring,

and sediment export analyses, each with corresponding conditions requiring corrective measures if previously agreed upon criteria were exceeded.

In at least one proceeding, a proposed stream channelization was prevented. Railroad crossings of streams not under 404 review have been realigned to achieve the shortest route possible with the least disturbance to flood plains.

Site-specific standards are often imposed in addition to what may be required by other agencies. For example, water quality standards for discharges may be imposed that are more stringent than those that are required by DEQ. Such standards are always discussed and agreed upon between the two agencies before implementation. This is an effective way to increase confidence in mitigations for particularly sensitive areas, and is an example of where overlap of jurisdiction may have positive environmental results.

Many examples exist where construction practices, sediment control techniques, and reclamation methods have been implemented only because of the Industrial Siting Process. Minimum disturbance widths at stream crossings have also been required.

One concept paramount to many successful mitigation efforts is that the awareness generated through negotiations with companies and other agencies will, in many cases, lead to applicants voluntarily committing to environmental safeguards. In this way progress has been made in extending sound environmental protection practices into areas not under direct Industrial Siting jurisdiction but that are tied to a facility which is. This has included wellfields and even components in neighboring states.

#### CONCLUSION

The need to minimize adverse impacts to riparian zones from oil and gas activity in the Overthrust Belt is becoming increasingly

evident as the industry rapidly expands operations. We conclude that sound construction practices and effective planning designed to prevent unnecessary disturbance are required to mitigate the types of impacts evident in riparian zones. However, regulatory control is often ineffective, not because of the lack of laws or regulatory agencies, but because of the lack of jurisdiction over certain facets of development and the inability to implement site-specific innovations. A broad, generalized regulatory authority capable of performing integrated analyses on all aspects of development is needed. Part of this concept is the idea that the awareness generated through arbitration can sometimes lead to substantial progress and innovation that would not have occurred otherwise. The Wyoming Industrial Siting Process lends itself particularly well to this approach. However, its effectiveness in accomplishing what it was designed to do has been paradoxically diminished by imposed exemptions.

#### LITERATURE CITED

- Skinner, Morris M. and Michael D. Stone. 1983. Identification of instream hazards to trout habitat quality in Wyoming. U. S. Dept. Int., Fish. Wild. Serv. FWS/OBS-83/13.
- U. S. Departments of Interior and Agriculture. 1978. Surface operating standards for oil and gas exploration and development. Bureau of Land Management, Geological Survey, and Forest Service publication. Denver, CO.
- VerPloeg, Alan J. and Rodney H. DeBruin. 1982. The search for oil and gas in the Idaho-Wyoming-Utah Salient of the Overthrust Belt. The Geological Survey of Wyoming. Report of Investigations No. 21. Laramie, WY.
- Wyoming Oil and Gas Conservation Commission. 1984. Wyoming oil and gas production by county. Wy. Oil and Gas Commission publication. Casper, WY.

# Evaluating Effects of Management on Riparian Ecosystems<sup>1</sup>

Martin M. Fogel and Peter F. Ffolliott<sup>2</sup>

---

Abstract.--Computer simulation of the hydrologic processes and biomass production is used to assess the effects of management to determine whether such actions are a deterrent to desertification of riparian ecosystems. This approach allows the evaluation to be made prior to implementing any action.

---

## INTRODUCTION

Desertification, defined herein as the loss of the land's productive capacity, has initiated much needed research into cause-effect relationships. The management of natural resources systems in a holistic context has become increasingly complex because these relationships are not always clearly understood. In addition, tradeoffs often need to be effected between users of the land, in this case riparian lands as managers attempt to respond to mandated planning requirements of federal, state and local environmental legislation. This study looks on evaluating those actions of man that may cause desertification to a riparian ecosystem.

Computer simulation is developed for both the physical and biological processes taking place on a riparian ecosystem as a means for assessing various options available to resource managers. System dynamics of riparian ecosystems are simulated to determine the complex interactions between environmental processes and management decisions. With the assumption that these simulation models are reasonable facsimiles of the real world, managers can determine the consequences of proposed actions prior to their implementation. This paper first presents a framework for a general systems models, then discusses the use of a stochastic set of daily weather variables which serve as inputs to models of watershed hydrology and biomass production, and finally reviews the subject of multiobjective decision making.

## GENERAL SYSTEMS MODEL

The accompanying illustration can be viewed as a system for managing a riparian ecosystem (figure 1). Two classes of actions serve as inputs to a particular system producing two sets of outputs. The climatic or meteorologic inputs to the system are largely uncontrollable by man, whereas management has some measure of control over land use and treatments and practices applied to the land. The resulting outputs are grouped into either economic or environmental indicators. Unlike the environmental group, a quantifiable value or utility can be assigned to the economic outputs.

A set of objective functions can be developed for managing such a system to indicate the relative importance of the outputs. Although an economic value may not be readily attached to an environmental indicator, mathematical programming is available for managing natural resources based on the objective functions and constraints.

To describe a riparian ecosystem in a precise manner, a discrete-state system model is defined formally. The elements of the model are as follows:

- (1) A time scale:  $t = 0, 1, 2, \dots$  where  $t$  is in seasons
- (2) The meteorologic variable inputs are:  
 $XM1(t)$  = daily precipitation  
 $XM2(t)$  = daily temperature and/or solar radiation
- (3) The decision variable inputs are:  
 $XD1(t)$  = designated land use  
 $XD2(t)$  = vegetative treatment such as removing or thinning vegetation  
 $XD3(t)$  = structural measures such as channel clearing or straightening

---

<sup>1</sup>Paper presented at the North American Riparian Conference [University of Arizona, Tucson, April 16-18, 1985].

<sup>2</sup>Professors of Watershed Management, School of Renewable Natural Resources, College of Agriculture, University of Arizona, Tucson, Arizona 85721.

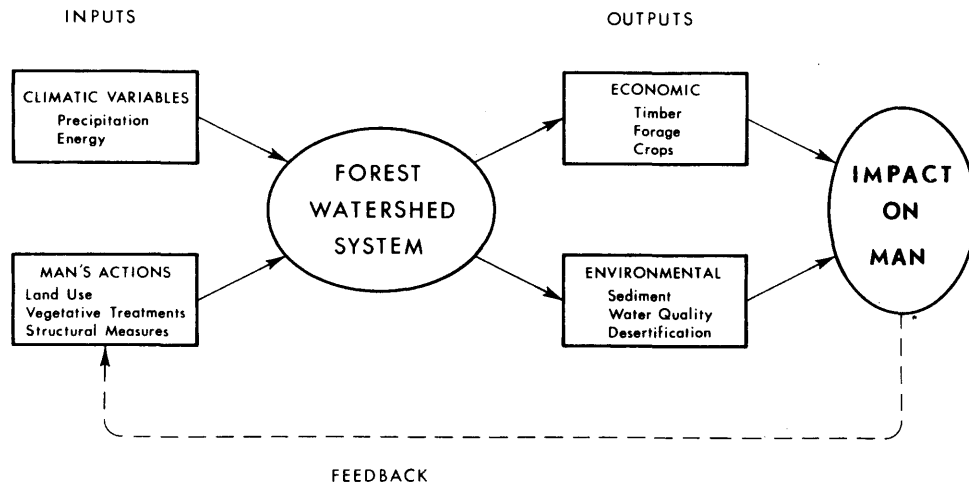

Figure 1.--Schematic Representation of Managing a Natural Resources (Forest) System.

- (4) The state of the system(S) is expressed by a term to represent the state of "health" or condition of the riparian ecosystem. It may be similar to the term range condition which represents the productive potential of the range rather than the immediate availability of forage (Stoddard et al., 1975). Another state of the system may be the groundwater level, which under certain conditions may also be indicative of the productive capacity of the land.
- (5) The state transition function F calculates the elements of the states at time (t + 1) as a function of the input and the state both at time t or

$$S(t + 1) = F[X(t), S(t)] \quad (1)$$

The function F is actually a vector set of functions which, predicts the future condition or state from the current S, the meteorologic variables XM(t) and the decision variables XD(t). Thus,

$$S(t + 1) = F[S(t), XM(t), XD(t)] \quad (2)$$

It is not necessary for the transition function to be given in quantifiable terms. In range management, for example, assume that the meteorologic variables making up the weather are denoted by either favorable, average, or unfavorable and that the decision variable is translated into a high or low grazing intensity. Then, if the range condition class

is excellent (EX), good (GD), fair (FA), or poor (PR), a table such as table 1 can be developed as the state transition function to predict the range condition at time (t + 1).

- (6) The systems output function transforms the inputs to the following outputs:

Y1 = volume of runoff per season  
 Y2 = volume of sediment per season  
 Y3 = quantity of biomass produced

These outputs are a function of the state of the system. For example, a range in poor condition will produce more runoff and sediment, but less biomass than a range in good condition.

In mathematical terms:

$$Y(t) = G[XM(t), XD(t), S(t)] \quad (3)$$

- (7) Finally, the feedback function reviews the output variables and the state of the system at time (t) and then makes decisions which become input variables at time (t + 1) or

$$XD(t + 1) = K[Y(t)] \\ = K[G[XM(t), XD(t), RC(t)]] \quad (4)$$

## SIMULATION MODELS

As seen in figure 1, two sets of outputs are produced from the riparian ecosystem, each of which requires a separate simulation model or output function. First, a hydrologic model is used to produce the environmental indicators of what is occurring on the land, such as the water yield, the sediment yield, and the water quality indices. Then, a biomass production model is used to determine the vegetative yield of the system. To drive both sets of simulation models, daily meteorologic variables are used.

### Simulating Weather Variables

It is well established that the climate of semiarid regions are variable in both time and space. Drought to flood conditions can occur in a very short interval of time. Historical hydro-meteorologic records often do not include these extremes and any subsequent analysis based on this incomplete record may be misleading. To avoid this problem, previously developed techniques for generating a synthetic time series of daily precipitation and temperature (and/or solar radiation) are used. Event-based, stochastic precipitation models developed by Fogel et al., (1974) and Duckstein et al., (1975) at the University of Arizona serve as inputs to watershed hydrologic models.

A daily temperature model developed by Hekman (1977) was used to provide the energy inputs.

### Modeling Riparian Hydrology

While several hydrologic models have been used for natural resource systems, most of them require more data than are normally available from riparian ecosystems for calibration and validation purposes. For this study, the U.S. Soil Conservation Service (1972) procedure for estimating runoff from rainfall has been found to be satisfactory for ungaged watersheds which can be divided into relatively homogenous

Table 1.--Range Condition as a Function of Weather and Grazing Intensity.

Range Condition at time t	Weather Condition/Grazing Intensity					
	Favorable		Average		Unfavorable	
	High	Low	High	Low	High	Low
EX	GD	EX	GD	EX	FA	GD
GD	GD	EX	FA	GD	FA	GD
FA	FA	GD	FA	FA	PR	FA
PR	PR	FA	PR	PR	PR	PR

subwatersheds, each no larger than approximately 10 km<sup>2</sup>. Using runoff volumes and peak flow rates determined by this technique, sediment yields are estimated by the Modified Universal Soil Loss Equation (1972).

In addition to its applicability to ungaged watersheds, the Soil Conservation Service method can incorporate the state such as the range condition as a factor in estimating the runoff potential of a riparian ecosystem.

### Biomass Production Modeling

Net primary production (NPP) is the total aboveground dry weight biomass produced per unit area in a growing season. According to Gilbert (1975), net primary production is assumed to be the difference between photosynthesis rate (PS) and the respiration rate (RS). While most models are on an annual basis, Gilbert (1975) developed a daily model for estimating PS and RS which uses daily estimates of available soil water content and temperature and is based on the following functional relationships:

Photosynthesis rate = f(temperature, soil water content, aboveground green plant biomass, and maximum PS)

Respiration rate = g(temperature, aboveground green plant biomass, and maximum RS)

The water content of the soil is simulated on a daily basis by calculating the infiltration (storm rainfall less runoff) and estimating daily evapotranspiration as a function of soil water content and potential evapotranspiration (PET). This latter term, PET, is calculated using daily temperature and/or solar radiation.

### MULTIOBJECTIVE DECISION MAKING

According to Horton and Campbell (1974), "to properly manage riparian and phreatophyte zones requires a knowledge of (1) the present community relationships, (2) the possibility of developing different vegetation types, and (3) the individual reactions of the various species that occupy the zone or that might be introduced under management." This paper does not address this level of management directly but recognizes that the above information must be incorporated into the decision-making process.

The purpose of this paper is to lay out an overall framework for evaluating management alternatives. The section that follows, therefore,

presents this decision-making aspect while cognizant of the fact that riparian areas may be used for a variety of uses. Thus, the problem becomes one of evaluating management alternatives under a multiobjective situation.

#### Managing Riparian Zones: A Continuous Review Process

In referring to the feedback function K, it is obvious that managing resources is in systems methodology, a continuous review process. By knowing the condition at any given time, the system's outputs (forage production, water, and sediment yields, etc. and the future condition can be predicted. Management actions, then, can be taken accordingly through the use of the feedback function.

It is evident that the decisions so made, formally or otherwise, are of the multiobjective or multicriteria type. Managers attempt to maximize economic returns while simultaneously trying to maintain good or better condition and to minimize erosion or other adverse environmental effects.

Through simulation of the system, it is possible to determine if (as the result of man's actions) a course is taken towards or away from desertification. One indicator of such a state is range condition, which can be used to identify the state of this process, as desertification is synonymous with a lowering of the productive capacity of the land.

#### Multiobjective Decision Making

Multiobjective optimization has been applied to water resource management for two decades, with some of the earlier techniques reviewed by Cohon and Marks (1975). Many of these can be used in land management in general and to riparian zones specifically.

As implied earlier, the environmental outputs of a natural resource system are often not quantifiable in monetary terms. Some type of ranking, weighting, or other means for distinguishing between objectives are needed to facilitate trade-offs by amounts of the objectives. Examples of mathematical programming techniques for accomplishing this include goal programming, compromise programming, surrogate worth trade-off method and ELECTRE (1976).

A straightforward procedure that has its roots in multiattribute utility theory, as presented by Keeney and Raiffa (1976), is an iterative computer algorithm called Evaluation and Sensitivity Analysis Program (ESAP). As used by West and Husaini (1982), this program has the advantage of being able to handle large data sets and can provide a systematic procedure for evaluating alternative plans of action that can be relatively different in scope. Another important advantage of ESAP is the direct manner in which it recognizes and deals with the

effects of uncertainty about either scientific and technical information or public values on the evaluation of alternatives.

In the context of planning, ESAP defines the subjective benefit resulting from the achievement of stated goals or objectives. It is assumed that the decision-maker's utility function can be specified numerically by obtaining his utility value for each criterion, and then combining these single utilities into one overall utility function. The system that provides the highest degree of utility for all the objectives is designated as the preferred alternative.

#### SUMMARY

This paper presents an approach to managing natural resource systems that relies on the computer simulation of the physical and biological processes that occur on such systems. It is well recognized that some of the models or techniques have not, as yet, been validated, making some of the results suspect. It is also recognized that these techniques are not widely used, probably because the real world demands political compromises which often require solutions other than those that rely entirely on mathematical equations and computer algorithms. However, such subjective decisions can be incorporated into the decision-making process through the use of decision-aiding techniques as ELECTRE and ESAP. In other words, political compromises can also be programmed on the computer, and with this understanding, the approach presented herein may one day be accepted.

#### LITERATURE CITED

- Cohon, J. L. and D. H. Marks. 1975. "A Review and Evaluation of Multiobjective Programming Techniques." Water Resources Research. Volume II, No. 2. pp. 208-220.
- David, L. and L. Duckstein. 1976. "Multi-criterion Ranking of Alternative Long-Range Water Resources Systems." Water Resources Bulletin. Vol. 12, No. 4. pp. 731-754.
- Duckstein, L., M. M. Fogel and D. R. Davis. 1975. "Mountainous Winter Precipitation: A Stochastic Event-based Approach." Proceedings, AGU Symposium on Precipitation Analysis for Hydrologic Modeling. Univ. of California, Davis. June 26-28, 1975, pp. 172-188.
- Fogel, M. M., L. Duckstein and J. L. Sanders. 1974. "An Event-based Stochastic Model of Areal Rainfall and Runoff." Proceedings, Symposium on Statistical Hydrology. USDA/ARS Misc. Pub. No. 1275. pp. 247-261.
- Gilbert, B. J. 1975. "Grassland Simulation Model." Range Science Series No. 17, Dept. of Range Science, Colorado State Univ., Ft. Collins, Colorado.

- Hekman Jr., L. H. 1977. "Simulation Evaluation of Water Yield Response to Vegetation Management on a Forested Watershed in Arizona." Unpublished Ph.D. dissertation. University of Arizona.
- Horton, J. S. and C. J. Campbell. 1974. "Management of Phreatophyte and Riparian Vegetation for Maximum Multiple Use Values. USDA Forest Service Research Paper RM-117. 23 p.
- Keeney, R. L. and H. Raiffa. 1976. "Decisions with Multiple Objectives: Preferences and Value Tradeoffs." John Wiley and Sons, New York.
- Soil Conservation Service. 1972. "Hydrology." Section 4, National Engineering Handbook. USDA/SCS, Washington, D.C.
- Stoddard, L. A., A. D. Smith and T. W. Box. 1975. "Range Management." McGraw-Hill, New York.
- West, S. A. and S. W. Husaini. 1982. "Evaluation and Sensitivity Analysis Program: Pilot Application to Saudi-Islamic Environmental Assessment." Journal of Engineering and Applied Sciences. Vol. 1, No. 3. pp. 237-250.
- Williams, J. R. and H. D. Brendt. 1972. "Sediment Yield Computed with Universal Equation." Journal of the Hydraulics Division, ASCE, Vol. 98, No. HY 12. pp. 2087-2098.



# The Boulder Creek Corridor Projects: Riparian Ecosystem Management in an Urban Setting<sup>1</sup>

David W. Crumpacker<sup>2</sup>

---

Abstract.--Protection of the riparian corridor of Boulder Creek is a major priority of the citizens of Boulder, Colorado. A description of how this is being accomplished and how the corridor will be managed for the benefit of the community is presented.

---

## INTRODUCTION

Boulder Creek is formed by the union of Middle and North Boulder Creeks 5 miles west of the City of Boulder, Colorado which lies at the base of the first Rocky Mountain uplift from the Great Plains. The Creek leaves Boulder Canyon at the western edge of the City where its mean annual flow approximates 100 to 200 cfs and it is classified as a 5th order stream. From this point it flows east northeast for 3.5 miles through the City with a mean annual flow near 50 to 100 cfs as a result of diversions, and thence northwest 18 miles through farms and rangeland to its confluence with St. Vrain Creek (pers. commun., Gary Lacy, Boulder Creek Project Coordinator, 1985).

Boulder Creek is the major natural feature of the Boulder Valley and has been since the City was founded on its banks in 1859. Its rocky substrate extends to a point well below the City of Boulder and it is classified by the State as a coldwater fishery throughout the City. It has very good water quality for aquatic life (Lewis and Saunders 1984). The physical habitat is less satisfactory because various sections through the City have been channelized or otherwise stabilized and only parts of the original riparian vegetation remain.

## CONTEXT FOR PRESERVATION

Formal recognition of the need to preserve Boulder Creek occurred as early as 1910 when

---

<sup>1</sup>Paper presented at the First North American Riparian Conference, "Riparian Ecosystems and their Management: Reconciling Conflicting Uses," Tucson, Ariz., April 16-18, 1985.

<sup>2</sup>David W. Crumpacker is a Professor of Environmental, Population and Organismic Biology, University of Colorado, Boulder, CO, and Ecological Consultant to the City of Boulder, CO.

Frederick Law Olmsted, Jr., Harvard professor and nationally known landscape architect, presented a plan for preservation of Boulder's mountain backdrop and streams as open space (Walker 1977). Nothing was done for many years. Then the City's population grew from 20,000 in 1950 to 38,000 in 1960, causing concern about loss of open space. Citizen action came in 1958 with an amendment to the City charter that established an elevation line of approximately 5600 feet above which the City would not supply water. This was intended to stop development of the mountain backdrop. However, the City had grown to 67,000 by 1970 and development pressures were increasing rather than abating. In 1967 the citizens voted a 0.4 percent sales tax to be used for acquisition, protection, and maintenance of open space lands (the "green-belt" program). The City grew to 80,000 in 1975 during a period that coincided with the passage of NEPA and other landmark federal environmental legislation. The citizens responded again with passage of a charter amendment in 1971 authorizing the City to issue bonds that would allow more rapid acquisition of open space and which could be paid off with future sales tax revenues. A citizens' Open Space Board of Trustees was formed in 1973 to recommend additional acquisitions to the City Council and a Boulder Valley Comprehensive Plan that united the City and Boulder County efforts to preserve open space was adopted in 1978.

The City now owns approximately 14,000 acres of open space, mostly on the mesas and plains, in addition to its 5,600 acres of mountain parks and reservoirs. The open space purchases have totaled \$36,600,000, not including interest on notes and bonds. The land has been acquired by immediate purchase, rolling options (seller agrees to sell property at a fixed price in pieces over time), notes and deeds of trust and, as a last resort, condemnation. The flexibility obtained from borrowing money through bonds, backed by the steady income from the sales tax, is a powerful approach. Important parts of the open space lands are left in agricultural use under City super-

vision in order to provide income for maintenance of the properties.

The City has now embarked on an exciting series of riparian projects. Four will be discussed, beginning upstream near the mouth of Boulder Canyon and continuing downstream 9 miles into the plains.

#### UPPER BOULDER CREEK CORRIDOR

This project involves 3.5 miles of the riparian corridor from near the canyon mouth to 55th Street. This reach of Boulder Creek passes through some of the City's busiest commercial areas and 5 urban parks before it reaches the vicinity of the Boulder Creek Cottonwood-Willow Grove. The project goals are to enhance the value of the riparian corridor as a place for both active and passive recreation, provide a major link to existing and proposed bike and foot trails, and simultaneously enhance the fish and wildlife habitats (City of Boulder, Department of Planning and Community Development 1984). Relatively undisturbed parts of the corridor will be preserved, while undeveloped but disturbed areas will be restored and improved. The stream channel including banks will be rehabilitated for aquatic life and a diversity of native vegetation will be planted as needed. Developed areas will continue to provide formal parks and recreational opportunities. Trout populations will be established and a fish management plan put into effect. Consideration will be given in the stream design to improvements for rafting and kayaking during high flows. Trails and bridges will be designed to direct traffic away from ecologically sensitive areas.

The City and cooperating public agencies such as the Boulder Valley School District and the University of Colorado currently control more than 95% of the land required for a continuous trail system in this part of the Boulder Creek Corridor. Selective acquisitions will be made over time to add unique or sensitive ecological areas, trail system entries and linkages, scenic amenities, and properties that will contribute to flood management.

In order to assure preservation of fish, vegetation, and wildlife, the City will devise a minimum flow strategy for the Creek based on the amount and seasonality of water rights that need to be acquired and dedicated to instream use. Exchanges, purchases, and trades will be considered and costs estimated. Low flows of 1-3 cfs have been measured in careful studies of the Creek near the upper and lower boundaries of the Upper Corridor (Pennak 1943, Lewis and Saunders 1984) and sections of this reach of the Creek have been observed to dry up temporarily during certain seasons and years at points below diversion ditches.

Under Colorado Senate Bill 97 passed in 1973, the State Water Conservation Board, upon advice from the Colorado Division of Wildlife, can appropriate water for instream flow for the purpose

of "protecting the environment to a reasonable degree." As a result of this legislation and subsequent action, the State now owns a junior water right for 15 cfs in Boulder Creek through the City. In addition, the State recently purchased a fairly senior water right in the same reach for 1 cfs during summer, with financial and legal aid from the Nature Conservancy, a national, private, non-profit organization dedicated to the preservation of ecologically significant lands and waters (pers. commun., David Harrison, president of the Colorado State Chapter of the Nature Conservancy). The deal was complex, involved initial purchase from a private party by the Conservancy followed immediately by sale to the State, and took several years to accomplish. This transaction is very significant because it represents the first transfer in Colorado of an agricultural water right to an instream flow water right. The City's Utility Department owns numerous senior water rights and a senior exchange water right that provide supplies in excess of its municipal needs in most years. Development of a strategy to manage the excess can provide some degree of minimum flow in Boulder Creek throughout the City in all but the driest years. Deep pools in the rehabilitated stream channel can also help to protect fish during extreme low flow periods.

Nearly \$2,000,000 has been included in the City's capital improvements budget over the 5-year period of 1984-1989 to support Phase I of the Boulder Creek Corridor Plan, i.e., the upper part of the corridor. This includes maintenance and management as well as improvements and limited acquisitions. Potential sources of additional support include the Urban Drainage District, state lottery funds, federal grants, and private fund raising.

#### BOULDER CREEK COTTONWOOD-WILLOW GROVE

On the City's northeast edge near the downstream end of the upper corridor, Boulder Creek flows through a 29-acre riparian woodland called the Boulder Creek Cottonwood-Willow Grove. Although the dominant tree in the Grove is the peach-leaved willow (*Salix amygdaloides*), numerous plains cottonwoods (*Populus sargentii*) of various ages and some narrowleaf cottonwoods (*P. angustifolia*) also occur. This is probably the largest riparian forest isolate left in the Boulder Creek flood plain and is especially unusual because of its rectangular rather than linear shape. The City is currently obtaining ownership of the Grove by one of its rare condemnation proceedings and has been managing the Grove under court order since 1983. Because the Grove is considered to be fragile open space, public access is not allowed and the area is used primarily by biologists from the University as a riparian field station only 10 minutes from the campus. It is hoped that some of the research results will be applicable to long-term management and preservation of the Grove and other riparian properties in the City and in Boulder County.

The Cottonwood-Willow Grove has been one of the most diverse sites in the entire Boulder Creek

Corridor. Observations over the last 15-20 years have identified the following species: approximately 150 birds, 14 mammals, and 6 fish (Cruz and Bock 1975). One hundred and seventy native and introduced species of vascular plants, including 16 tree species, were recently identified (unpubl. data, Jane H. Bock, 1983). University of Colorado biologists are just completing a major year-long inventory of the birds, small mammals, vegetation, water quality, and air quality in the Grove.

#### LOWER BOULDER CREEK

In early 1983 the City, in cooperation with Colorado Open Lands (COL), a non-profit, public-purpose foundation dedicated to preservation of open space, began a project to reclaim and preserve approximately 3 miles of the Boulder Creek Corridor downstream from the Cottonwood-Willow Grove and outside the City limits (Design Studios West undated). The land was owned by the Flatiron Company of Boulder and used in their extensive gravel mining operations. This remarkable project, which will benefit all 3 organizations, is now well underway. COL acted as the facilitator and hundreds of hours of negotiation were required over a 2-year period.

Although current Boulder County zoning would allow residential and commercial development of the riparian lands involved in this project, the Flatiron Company made a \$15,000 cash grant to COL to develop a preservation plan and also agreed to implement a reclamation plan developed by COL and give them the properties! The fair market value of the first gift was determined to be \$1,849,000, of which approximately half could be used as a tax deduction by Flatiron, based on their administrative structure. This provided less benefit to Flatiron than the company would have realized from an open market sale. However, Flatiron will receive a sizable tax deduction from the reclamation work and will realize considerable public relations benefits in the City and County.

The City has agreed to buy the properties from COL at a bargain sale price which is less than 20% of the appraised fair market value. In the first phase of this project, the City purchased \$1,849,000 of riparian corridor lands at \$350,000. COL plans to use this payment in its future land preservation operations that will include establishing a revolving fund to provide support for other state projects. The second and third phases of the project, which are scheduled for 1985 and 1986, will be structured similarly but the purchase prices have not been finalized.

The Lower Boulder Creek Project will balance the needs for flood control and transportation in that area, while taking advantage of environmental opportunities that are consistent with the City's open space philosophy. Major benefits of the project will be as follows:

1. Connection of open space lands in the Upper Boulder Creek Corridor with City and County

riparian open space lands 3 miles to the northeast in the vicinity of Sawhill Ponds and with City conservation easements 2 miles farther east in the White Rocks riparian area.

2. Improvement of the visual quality of the Boulder Creek Corridor by reclaiming the Creek and adjacent mined lands.

3. Enhancement of fish and wildlife riparian habitat in this generally arid region.

4. Preservation under controlled livestock grazing of the terrestrial uplands adjoining the riparian corridor to provide feeding habitats for raptors and mammalian carnivores that reside in the riparian habitat.

5. Completion of the extension of Pearl Street that has been an element of the Boulder Comprehensive Plan for nearly 15 years, while simultaneously preventing the commercial and residential sprawl that would normally accompany a new transportation link through a riparian corridor.

6. Construction of flood protection improvements in this part of the Boulder Creek Corridor that are compatible with the use of certain open space lands to accept excess water during years of exceptional flooding.

7. Linkage of the Upper Boulder Creek Corridor pedestrian and bike trails with the South Boulder Creek Trail and with other trails in the vicinity of Sawhill Ponds and White Rocks, plus provision of a new equestrian trail.

8. Construction of an open space buffer on the north side of the Boulder Creek Cottonwood-Willow Grove in the form of an 8-acre lake with an adjacent reclaimed prairie and small stand of large plains cottonwoods. This will greatly enhance the biological diversity in the vicinity of the Grove which is already bounded on the east by a cattail pond and marsh that is owned and protected by the Syntex Corporation. The new lake will provide a limnological research facility of medium depth for the University's aquatic biologists in addition to an open space amenity for the City.

9. Provision of a deep water limnological research facility for the University and another open space amenity by acquiring a 60-foot deep, 10-acre lake 1/2 mile northeast of the Cottonwood-Willow Grove that was formed a number of years ago by gravel mining.

With the exception of the 2 lakes in the vicinity of the Cottonwood-Willow Grove, the numerous remaining lakes and ponds in the Boulder Creek Corridor are relatively shallow and more suited for shore and wading birds and for aquatic birds and mammals. In return for use of the 2 limnological facilities, the University has agreed to use some of its water rights to keep the new lake just north of the Grove filled and has provided funds to the City for use with the legal

## CONCLUSION

and engineering work needed prior to diversion of its water for this purpose. The City will construct the diversion.

## WHITE ROCKS

After Boulder Creek passes through the Sawhill Ponds Area 3 miles northeast of the Cottonwood-Willow Grove, it flows along the base of the White Rocks geological formation at the extreme northeast end of the Boulder Creek Corridor planning area. This is a 300-acre site of exceptional beauty and fragility that contains a number of rare plant and animal species. The massive white sandstone cliffs extend for a mile along the north side of the Creek. This outcrop supports a rather luxurious vegetation because of seepage from the lower face of the formation. Here in the shade from the ledge are found Asplenium andrewsii, one of the rarest ferns in North America, and the only known Colorado specimens of Aristida basiramea (Harvard three-awn, a grass) and Apios americana (ground-nut, a legume with red-purple flowers). The White Rocks area also contains 4 rare species of ants, a rare mining bee (Perdita opuntia) and a rare fairy shrimp (Branchinecta packardii). Great horned owls and the only barn owls in the Boulder Valley nest on the cliffs. In general, the site contains a diverse collection of mammals, birds, amphibians, and reptiles (Stoecker 1972).

The City purchased a conservation easement in 1982 on 200 acres of the White Rocks area that contain the rare plants and animals mentioned above, with the aid of a low interest loan from the Colorado Chapter of the Nature Conservancy. The funds involved in this loan had been raised by the Conservancy from various private sources. When the City paid off the loan in 1984, the Colorado Chapter of the Conservancy was then able to use the City's payment to initiate its own Colorado Land Preservation Fund.

Because of its exceptional flora and fauna, White Rocks has been ranked by the Colorado Natural Areas Program as one of the most important natural areas in the state. It has also been nominated as a national natural landmark by the National Park Service. The remaining 100 acres of White Rocks to the west of the City's conservation easement have been officially designated as a State Natural Area by permission of the owner. Thus the entire 300 acres of this highly valued part of the Boulder Creek Corridor is now protected.

The riparian ecosystem preservation and management activities described in this report demonstrate how effective an informed and active citizenry can be if it wants to preserve ecological values. Skilled public and private organizations are ready to help. Various tools are available for accomplishing this goal. The Boulder Creek projects have depended heavily on land purchases funded by a reliable source of tax revenue and on a willingness to use the acquired lands for various purposes that benefit the local community.

## LITERATURE CITED

- Cruz, Alexander, and Jane Bock. 1975. The Boulder Creek cottonwood grove. Preliminary report. 24 pp. Department of Environmental, Population and Organismic Biology, University of Colorado, Boulder, Colo.
- City of Boulder, Department of Planning and Community Development. 1984. A plan for Boulder Creek. City of Boulder, Boulder, Colo.
- Design Studios West. Undated. An open space plan for lower Boulder Creek. Concept plan. 12 pp. and 7 fig. Design Studios West, Denver, Colo.
- Lewis, William M., Jr., and J. F. Saunders, III. 1984. Stream chemistry and precipitation chemistry at the Boulder Creek Cottonwood Grove. Report to the City of Boulder, Department of Planning and Community Development. 15 pp. plus 12 pp. of data. Department of Environmental, Population and Organismic Biology, University of Colorado, Boulder, CO.
- Pennak, Robert W. 1943. Limnological variables in a Colorado mountain stream. The American Midland Naturalist 29: 186-199.
- Stoecker, Robert E. 1972. Fauna of the White Rocks vicinity. In Application for mining and reclamation permit for the White Rocks pit. Flatiron Paving Co., Boulder, Colo.
- Walker, Donald V.H. 1977. Boulder preserves open space. Urban Land 36(9): 4-10.

# Using Visitor Perceptions in River Use Planning, 1972 - 1984<sup>1</sup>

Kenneth C. Chilman, David Foster, and Alan Everson<sup>2</sup>

---

Abstract.--Recreational carrying capacity determination for large wildland areas is a complex and controversial topic. Visitor perception data has been gathered periodically since 1972 at Ozark National Scenic Riverways. It provides strong support for the carrying capacity rationale used for river use planning there. Implications for other carrying capacity situations are discussed.

---

## INTRODUCTION

An important issue in river use planning is recreational carrying capacity. How many canoes (or other watercraft) can float a river without unacceptable impairment of river ecosystems or quality of recreation visits? For large and diverse wildland areas, such as Ozark National Scenic Riverways (ONSR) in south central Missouri, carrying capacity has been especially complex and controversial. A river research program designed to gather various kinds of data for carrying capacity planning, including visitor perceptions measurements, has been done four times since 1972. Data from these research efforts have been useful in public hearings, court cases, and current river use planning efforts.

Advances have been made recently in recreational carrying capacity theories. Carrying capacity is now considered as a set of conditions to be managed for, rather than simply a calculation of numbers of visitors allowed (Stankey et al 1984). The set of conditions to be maintained for a recreation area or a portion of an area can be arrived at by deciding what is appropriate considering the spectrum of comparable opportunity settings available, as indicated by recreation inventory techniques (Chilman and Hampton, 1982).

In particular, recreation visitors' perceptions can provide insights about (1) what range of opportunities exist, (2) changes occurring in opportunity settings, and (3) appropriate use densities for particular situations. This paper discusses the complex river use planning situation

at ONSR, how visitor perception data have been obtained, and how these data have been useful in carrying capacity planning.

## HISTORY OF ONSR RIVER USE PLANNING

The complexity of recreational carrying capacity planning is indicated by the fact that river use planning for ONSR began in 1972, and is still continuing. The first river use plan is now in draft form and should be submitted for public review this year.

Ozark National Scenic Riverways was established in 1964 as the nation's first Scenic Riverway. The National Park Service (NPS) has responsibility for administering some 134 miles of the Current and Jacks Fork Rivers and the land corridor adjoining the rivers (fig. 1). The area was set aside as a Scenic Riverway because of its cold, clear, and moderately swift rivers, fed by large springs. It contains classic examples of Ozark mountain scenery, and examples of native Ozark cultural activities for interpretive programs, which the NPS maintains.

These characteristics, plus proximity to St. Louis, Missouri (about 150 miles), make the area a favorite for canoeists. From an estimated 40,000 floater days in 1968 (some floaters camp overnight along the rivers on more than one-day trips), use increased rapidly to 142,850 floater days in 1972. Concerns of park staff led to initiation of a five-year river research program in 1972, accompanied by a moratorium on increasing the number of canoes rented by NPS concessioners.

In 1976, a local court judge ruled that, because county roads crossed the Riverways, anyone desiring to rent canoes could use those

---

<sup>1</sup>Paper presented at North American Riparian Ecosystems Conference, University of Arizona, Tucson, April 16-18, 1985.

<sup>2</sup>Kenneth C. Chilman, Associate Professor, Southern Illinois University, Carbondale, Il., David Foster, Biologist, Ozark National Scenic Riverways, Van Buren, Mo.; and Alan Everson, Associate Professor, University of Missouri, Columbia, Mo.

## Methods

A limited number of visitor perception studies on large wildland areas had been reported by 1971 (Lucas, 1964; Hendee *et al.*, 1968). Thus, the objectives of our 1972 perceptions study were (1) to develop an appropriate methodology for gathering visitor data for management planning purposes on rivers used for canoe floating, and (2) to determine whether canoeists perceive crowding on the float river studied. A major concern in developing appropriate methodology was the problem of obtaining a sample of canoe floaters that would represent the diverse conditions of 134 miles of float rivers, with essentially no budget. A second concern at that time was to minimize interference with the visitor's trip experience.

Previous wildland visitor studies in Missouri had utilized a short on-site interview with a follow-up mail questionnaire (Gisi, 1971; Duffield, 1972). This allowed the interviewer to explain the purpose of the study and ask a few questions on-site, and then to obtain more detailed information from a mail questionnaire. Return rates on the Missouri questionnaires had ranged from 56% to 85%. There had been no objections by interviewers about being questioned.

To obtain samples of canoeists over the 134 miles of ONSR rivers, a system of stratified sampling was utilized. The Riverways was divided into three sections (fig. 2) representing

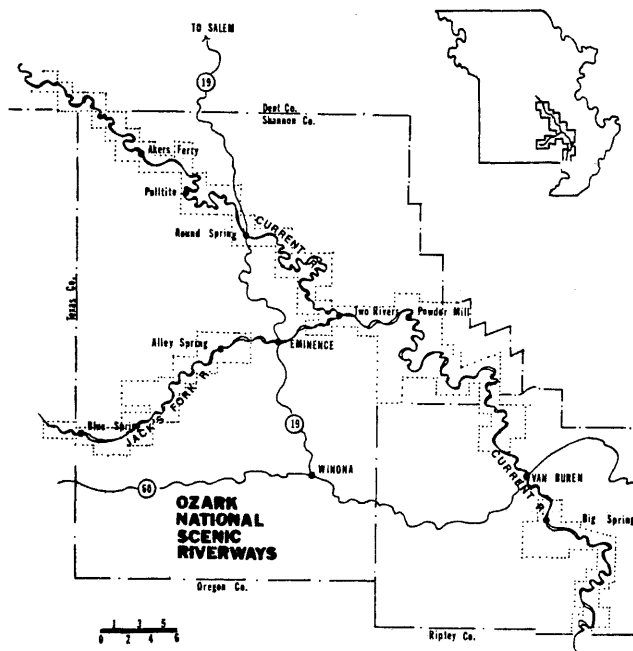

Figure 1.--Map of Ozark National Scenic Riverways

roads as public accesses. This created an influx of non-permitted canoe rentals, raising floater days to 243,000 in 1977. A series of legal actions finally culminated in a federal court ruling in 1982 that the NPS had the right to control rental businesses operating on the Riverways. Following a series of appeals, the NPS began work on drafting a river use plan in 1984.

The research program now included a series of integrated baseline studies of numbers of canoeists, their impacts on the river environments (riparian ecosystems, water quality, and aquatic life), visitors' perceptions, and safety considerations (Marnell *et al.* 1978). The perception studies were repeated in 1977, 1979, and 1984, along with monitoring of canoeist numbers and water quality. It is these repeated measurements that have proven particularly useful for river use and carrying capacity planning.

### OBTAINING THE VISITOR PERCEPTION DATA

A perception includes information obtained by any number of a person's different senses from a part of the environment that is of special interest. For the studies discussed here, we asked canoeists about aspects of float trips they had recently experienced. Although perception data have been gathered to learn about various aspects of float experiences as indicated above, this report will focus on perceptions of crowding which have been the most useful for carrying capacity purposes at ONSR. A summary of methods of data collection used in the four studies will be followed by an overview of results obtained.

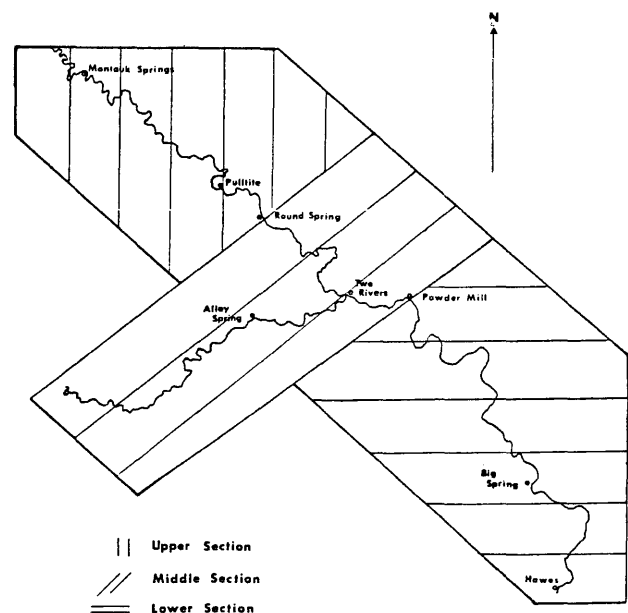

Figure 2.--Stratified sampling design for visitor perception data collection.

differences in water conditions and river use (Habermehl, 1973). Within these sections, interviews were conducted at major vehicle access points where floaters ended their float trips and took their canoes out of the water.

Interviews were conducted on 12 randomly selected weekend days (Saturdays, Sundays) and 18 randomly selected weekdays between June 1 and August 7, 1972. The sampling hours were from 11:00 a.m. to 7:00 p.m., during which time almost all ONSR canoeists terminate float trips. During the sampling period, 307 interviews were conducted. With two follow-up letters, a total of 285 of the 307 mailed questionnaires were returned for a response rate of 92.8 percent.

The three questions that were used to indicate perceptions of crowding were (1) was this (section of the river) more crowded than you had expected, about what you had expected, or less crowded than you had expected, (2) was this more crowded than you desire, about right, or less crowded than you desire, and (3) has the number of floaters been a problem to you? If respondents answered "yes" to the last question, they were asked to explain how other floaters had been a problem to them. Other questions in the interview and questionnaire were used to obtain information about the canoe floaters and their trip experience.

Essentially, the same research design was followed in the 1977 and 1979 studies (Andrews, 1978; Chilman, 1979). In 1984, however, a different sampling design was followed in which interviews were entirely on-site and conducted in combination with use counts. A new canoe use configuration had occurred because of changes in NPS controls over canoe rentals, and the NPS wanted more specific counts of how canoe concessioners were operating on various river sections.

Ten river use zones were identified, each approximately an easy one-day float trip from major access to major takeout point (fig. 3).

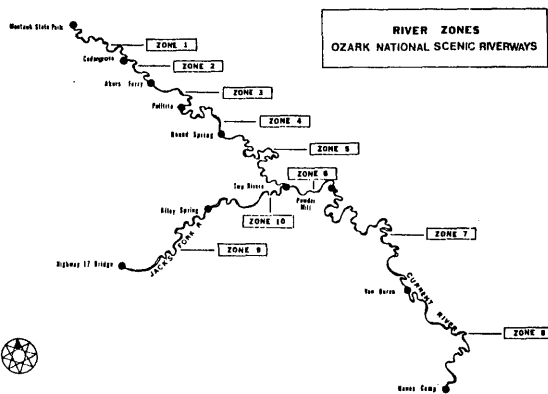

Figure 3.--Zone designations for monitoring and reporting river-use statistics at ONSR.

Short visitor interviews, including the perception of crowding questions, were conducted at eight river accesses representing eight of the zones (two zones were not sampled because their use was early season or very low). Sampling was done at each of the eight accesses on one weekend day and one weekday during each of June, July, and August. A total of 568 interviews were conducted; no mail questionnaires were used.

## Results

The results of the 1972 perceptions study were different than anticipated by the ONSR staff. The responses indicated that 23.5 percent perceived crowding to be more than expected, 27.4 percent perceived crowding to be more than desired, and 14.7 percent perceived crowding to be a problem. The ONSR staff had begun to receive visitor complaints and media coverage about canoe crowding occurring, but the results of the study did not appear strong enough to be a carrying capacity rationale. Consequently, research efforts moved to explore other dimensions of the situation.

In 1977, a remeasurement of the perceptions of crowding was done incidental to other research (Andrews, 1978). The 1977 data indicated that a substantial change had occurred in visitors' perceptions of crowding at ONSR (table 1).

Table 1.--Visitors (percent) perceiving crowding occurring during canoe trips at ONSR.

	1972	1977
Crowding more than <u>expected</u>	23.5	32.6
Crowding more than <u>desired</u>	27.4	51.4
Crowding as a <u>problem</u>	14.7	34.3

The total ONSR canoe use had increased from 142,850 floater days in 1972 to 243,000 floater days in 1977, these totals both carefully measured with time-lapse photography (Marnell *et al.*, 1978). Increases in perceptions of crowding now appeared to relate closely to increases in river use densities. It should also be noted that the perceptions of crowding percentages were similar on the less used Lower and Middle sections of ONSR to the heavily used Upper section, suggesting that some floaters were making conscious choices to avoid high density areas and then were finding increased use of low density sections (Chilman, 1979).

Because the findings above appeared significant, a follow-up replication was conducted in 1979. Total canoe use had increased to approximately 300,000 floater days in 1979, and perceptions of crowding again showed an increase (table 2).

Although increases in 1979 in the desired and problem categories occurred as expected in relation to total use, the drop in expected crowding responses appeared related to visitors being told to "expect to see lots of canoes" by previous visitors.

Table 2.--Visitors (percent) perceiving crowding occurring during canoe trips at ONSR.

	1972	1977	1979
Crowding more than <u>expected</u>	23.5	32.6	30.9
Crowding more than <u>desired</u>	27.4	51.4	52.5
Crowding as a <u>problem</u>	14.7	34.3	37.1

The three remeasurements of perceptions of crowding appeared to indicate deterioration in quality of float trip experiences at ONSR. The problem was to decide what level of perceived crowding would be defensible in carrying capacity decision-making. A level of zero perception of crowding appeared unrealistic, given the diversity of floaters and float experiences. On the other hand, could a level of twenty percent or thirty percent or forty percent be defended as "acceptable?"

Another substantial change had occurred in total ONSR canoe use when a 1983 federal court decision reduced canoes available for rent by approximately twenty percent. The 1984 remeasurement of perceptions of crowding occurred in connection with measurement of the new use configuration. A reduction in crowding perceptions was recorded (table 3).

Table 3.--Visitors (percent) perceiving crowding occurring during canoe trips at ONSR.

	1972	1979	1984
Crowding more than <u>expected</u>	23.5	30.9	28.0
Crowding more than <u>desired</u>	27.4	52.5	30.5
Crowding as a <u>problem</u>	14.7	37.1	8.0

In addition to the reduction in percentages of canoeists perceiving crowding, the intensity of responses of those reporting crowding perceptions appeared to be less than previous studies. Interviewees would often respond "yes, I would like to see a few less canoes, but it is not a big problem." This suggests that in future monitoring remeasurements, it may be well to record intensity of perception as reported in the Buffalo National River Use Management Plan (USDI, 1983).

How are these remeasurement results to be used in the ONSR river use planning strategy? What will be their use in future river management?

#### USING THE PERCEPTION DATA IN CAPACITY PLANNING

The perception of crowding measurements are being used in two ways for ONSR river use planning. The carrying capacity rationale being used in the ONSR plan follows the capacity rationale used successfully in the Buffalo National River Use Management Plan (USDI, 1983). That rationale stemmed from Wagar's (1966) "quality in outdoor recreation" concept that recreation visitors come to an area for different reasons and thus a range of opportunities should be provided rather than one average condition. For the Buffalo River, located in the Ozarks of northwestern Arkansas and similar in length and conditions to ONSR, this meant identifying three levels of use--near-wilderness (up to 8 canoes per mile), moderate use (between 9 and 20 canoes per mile), and high use (over 20 canoes per mile)--to be maintained to provide a choice of recreation experiences.

A similar range of use conditions was found to exist on various ONSR river zones during the

1984 visitor study. Management to maintain three different levels of use on specific zones will provide a choice of float experience conditions for visitors.

The first way that visitors' perceptions of crowding data will be used is by concluding that the overall level of perception of crowding (30.5 percent) in 1984 appears in the "acceptable" range. The second way the data will be useful will be to focus management efforts on zones and times where perceptions of crowding are highest (above 30 percent) and to suggest measures (such as providing information to visitors about less crowded zones) to improve visitor satisfaction in those zones. A monitoring system for future visitor counts and perceptions will be an important part of that strategy, and is designed for implementation with the ONSR river use plan.

#### CONCLUSIONS

An exceptional combination of circumstances has occurred at ONSR. Not only have a series of remeasurements of visitors' perceptions taken place since 1972; it has also been possible to remeasure after available rental canoes have been increased, then reduced substantially. Percentages reporting crowding perceptions have related directly to amounts of total use. The most recent measurement indicates "acceptable" levels now, but suggests limits on further increases pending further monitoring.

A major finding of these studies was that one season of perception measurements did not prove very helpful for planning purposes, but a great deal was learned from the series of measurements over time. The importance of remeasurements of changing conditions as a monitoring system over time has been emphasized in various writings on capacity theory (Chilman, 1981; Washborne, 1982; Stankey et al. 1984).

A difficulty with implementing monitoring systems has been their costs in a time of dwindling recreation management budgets. The simple, low-cost measurements used in the ONSR have effectively solved this problem (at ONSR). They should prove to be useful instruments in various complex carrying capacity situations (Chilman, 1985). With these tools, river capacity planning and management can be a much less uncertain, and more rewarding, endeavor.

#### LITERATURE CITED

- Andrews, Michael A. 1978. Perceptions of crowding by canoe floaters in relation to the floating baseline concept. Research report submitted to National Park Service, Van Buren, Mo. 41 p.



- Chilman, Kenneth C. 1979. Remeasurements of perceptions of crowding as a tool for recreational carrying capacity determination. Paper presented at second conference on scientific research in the national parks. (San Francisco, Calif., November 26-30, 1979). Department of Forestry, Southern Illinois University, Carbondale, Ill. 16 p.
- Chilman, Kenneth C. 1981. Putting recreation research to work: a carrying capacity strategy. p. 56-61. In Some recent products of river recreation research. USDA Forest Service General Technical Report NC-63, 61 p. North Central Forest Experiment Station, St. Paul, Minn.
- Chilman, Kenneth C. 1985. (In press.) Monitoring trends in recreation quality with a recreation resource inventory system. Proceedings of national symposium on outdoor recreation trends II. (Myrtle Beach, S.C., February 25-27, 1985) Department of Parks, Recreation, and Tourism Mangement, Clemson University, Clemson, S.C.
- Chilman, Kenneth C., and Glenn Hampton. 1982. A new recreation inventory system to aid land management decision-making. p. 42-44. In Forest and river recreation: research update. Misc. Public. 18-192. Univ. of Minn. Agricultural Experiment Station, St. Paul, Minn.
- Duffield, Benny. 1972. Comparison of float trip recreation opportunities by visitors to the Eleven Point River. 78 p. M.S. thesis, Univ. Missouri, Columbia, Mo.
- Gisi, Donald V. 1971. Recreation expectations of first-time visitors to the Ozark National Scenic Riverways. 53 p. M.S. thesis, Univ. Missouri, Columbia, Mo.
- Habermehl, James M. 1973. Determininig visitor perceptions of crowding on Ozark National Scenic Riverways. 103 p. M.S. thesis, Univ. Missouri, Columbia, Mo.
- Hendee, John C., William R. Catton, Larry D. Marlow, and C. Frank Brockman. 1968. Wilderness users in the Pacific Northwest--their characteristics, values, and management preferences. USDA Forest Service Research Paper PNW-61, 92 p. Pacific Northwest Forest and Range Experiment Station, Portland, Oregon.
- Lucas, Robert C. 1964. Wilderness perception and use: the example of the Boundary Waters Canoe Area. Nat. Res. Jour. 3(3): 394-411.
- Marnell, Leo F., David Foster, and Kenneth C. Chilman. 1978. River recreation research at Ozark National Scenic Riverways. 139 p. National Park Service, Van Buren, Mo.
- Stankey, George H., Stephen F. McCool, and Gerald L. Stokes. 1984. Limits of acceptable change: a new framework for managing the Bob Marshall wilderness complex. p. 33-37. Western Wildlands Fall 1984.
- U.S. Department of the Interior, National Park Service. 1982. Buffalo national river use management plan. 47 p. National Park Service, Harrison, Arkansas.
- Wagar, J. Alan. 1966. Quality in outdoor recreation. Trends in parks and recreation 3(3): 9-12.
- Washborne, Rondel F. 1982. Wilderness recreational carrying capacity: are numbers necessary? Jour. Forestry 80(11): 726-728.

# The Site Signature Method of Land Suitability Planning in River Corridors<sup>1</sup>

David P. Hill <sup>2</sup>

---

Abstract—This performance-based methodology was developed for location and construction of a variety of land uses in fragile environments. Landscape character and land uses are represented by graphic "signatures." Through synthesis, a land suitability plan is created. Site specific performance criteria assure environmental protection while allowing developers locational flexibility.

---

## INTRODUCTION

Nearly all North American cities are sited along river corridors, but few have been able to effectively plan for the variety of land uses desired along the river banks. The complex physical and biological systems of the river corridor are seldom addressed by conventional zoning controls. The unique aesthetic and cultural systems of the river corridor are likewise ignored, or if addressed the controls are frequently cumbersome prescribed amendments. The river corridor becomes a jumble of innappropriately sited land uses. The riparian ecosystem suffers from the abuses of insensitive land development, and citizens suffer from the loss of a scenic and biological resource.

The Site Signature Method is being developed as a flexible planning process for location and construction of multiple land uses in fragile environments without loss of the existing natural and social amenities. Based on the tenet that conventional zoning does not adequately address the synergism of characteristics in diverse environments, this method provides a process that analyzes the biological, cultural, aesthetic and physical character of the existing landscape. This includes all pertinent information from the scientific community to establish important indicators of and rules for river health.

A key feature of this method is applied community input. To fit future development with the existing social fabric, the community decides the site character desirable for each proposed land use. The product of this exercise, a flexible multi-use plan, is liberal in locational requirements for proposed land uses.

The flexible plan is appropriate because in diverse and fragile environments, the question is not so much "where" development occurs, but "how" it occurs. The methods of construction and land management determine the future health of a river corridor. Developers will be the first to declare that for profit, "location is everything." The Site Signature Method allows the developer some flexibility in land use location, but requires the design meet site specific performance criteria before construction can begin.

By allowing developers leeway to choose the sites with more profit potential, they can afford to invest in a more intelligent design. The design must perform to design criteria based on the carrying capacities of the river corridor as established by the scientific community. The result is a river corridor planned according to the wants of the public and designed to the satisfaction of the scientific community.

## INVENTORY AND ANALYSIS

The first step of the process is to tailor the study to the region. A river corridor in a mountainous region will have a different character than a river corridor in a coastal plain. A region whose people have been conservative with land development will have a different character than a region which has had liberal land development. This trait is easily detectable in the landscape, and important in setting up the landscape inventory and planning program. A preliminary survey is circulated within the community to understand the collective attitude toward the river. These actual and perceived traits of the physical and social landscape compose the "character of the region," and set a framework for site inventory.

With an understanding of the character of the region, the river corridor boundary is determined. Normal determinants for the study boundary include the visibility of the river, the existing land use patterns and jurisdictional boundaries, the extent of the floodplain and first

---

1. Paper presented at the first North American Riparian Ecosystems Conference. (University of Arizona, Tuscon, April 16-18, 1985.

2. David P. Hill is Apprentice Landscape Architect with the Caplinger Group, Ltd., New Orleans, La.

order watershed. Inside the study area boundary, the river corridor is divided into sites for more intense study. Sites vary in size depending on existing landscape patterns, such as property lines, bridges, roads or the crests of hills. In the United States, the Army Corps of Engineers measures rivers in miles above the mouth, and their data serves well here to mark sites. Depending on the frequency of change in the landscape, sites have longitudinal boundaries at intervals of half mile, one mile, five miles, and can be referenced by the A.C.E. river mile number.



Figure 1.—Portion of the River Corridor for the Roanoke River in Southwestern Virginia. Note river miles, boundaries at 1/2 mile events in the landscape.

Each site is an area from the centerline of the river to the respective left or right lateral boundary. A study with one mile longitudinal site boundaries will have two sites per mile, one on each side of the river.

The Site Signature Method analyses the landscape in two ways. The MAGNITUDE of the landscape is a quantitative statement about how much or how great site characteristics are. The CONDITION of the landscape is a qualitative assessment about the health of sites. These terms were used by Jones and Jones (1973) in the Nooksack Methodology. The Site Signature Method uses magnitude to determine character for land use location, and condition is applied to establish site specific performance design criteria.

This method studies four dimensions of the landscape: biological, cultural, aesthetic and physical. Each of the four dimensions is composed of characteristics that can be found along the river corridor. The magnitudes and conditions of each characteristic are noted on the "sitesheet" for each site.

Magnitudes are totalled for each dimension and these totals are the basis for the "site signature." The site signature represents a site just as a person's signature represents the character of that person. It is the endorsement of the amounts on the sitesheet, like a person's signature is the endorsement representing the amount of a personal check.

## RIGHT 372.0

CONDITION	DIMENSION	CHARACTERISTIC	MAGNITUDE	NOTES
				Date: 10/85 By: JAH
*	BIOLOGICAL	FLORA Type Score FAUNA Type Score RIVER FLORA Type Score RIVER FAUNA Type Score BIOLOGICAL SCORE Unadjusted Adjusted	1.5 1.5 3.0 3.0 6.0 6.0	* = VARIETY YELLOW PINE, WHITE OAK, Sycamore AGRICULTURE - 50%, DOMESTIC - 30%, RECREATION 20 SERIAL PATCHES * = UNIQUENESS - 2 THREATENED FISH SPECIES FRANCIS LOGCAMP, OPIHINED BAYOU
*	CULTURAL	ARCHAEOLOGICAL SITES Number Score HISTORICAL LANDMARKS Number Score CURRENT LAND USE % Industrial/Support % Commercial/Institutional % Residential % Agricultural % Recreational/Idle ACCESS Site Access Potential Access Access to River CULTURAL SCORE Unadjusted Adjusted	2 0 0 15 15 17 2 2 2 10.5 3.0	* = FEASIBILITY 10% + 5% + 5% CURRENTLY - DRAGGING  LOW WATER BRIDGE @ SR. 654
*	AESTHETIC	FORM Prominent Landforms Contrast of Landmarks EDGE Clarity of Edge LANDSCAPE INTEGRITY RIVER FORM Islands, Pointbars, Outcrops Pools, Holes, Falls, Riffles SPACE View From River Sense of Enclosure RIVER INTEGRITY WATER QUALITY AESTHETIC SCORE Unadjusted Adjusted	5 3 3 2 2 2 3 3 3 2 2 2 2 24 2.0	* = UNIQUENESS - MOST IN STUDY AREA  * = ENCROACHMENT - DUMP CLIFF OVER RIVER FISHING HOLE - V.M. X OPT.  H
*	PHYSICAL	FLOODPLAIN % of Land Score SOILS Erodibility Foundation Suitability Sediment Suitability SLOPE 0-4 % 7-12 % 12-25 % 25 % + Score DEPTH TO BEDROCK GROUNDWATER RECHARGE PHYSICAL SCORE Unadjusted Adjusted	5 0.5 3 3 3 40 12 20 10 2 15.5 1.4	* = HAZARD NO STRUCTURE CURRENTLY IN FLOODPLAIN CARBINA - U.S.P.A. #1 AGRICULTURE  MINOR RECHARGE POTENTIAL

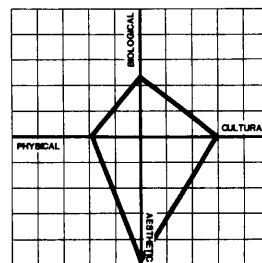

SITE SIGNATURE Right 372.0



Figure 2.—Sitesheet for the right bank site at mile 372.0 along the Roanoke River.

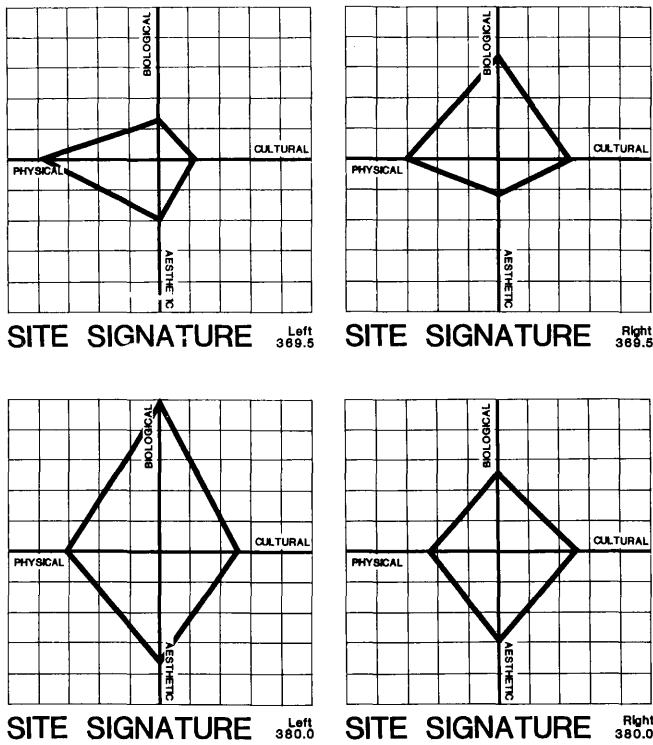
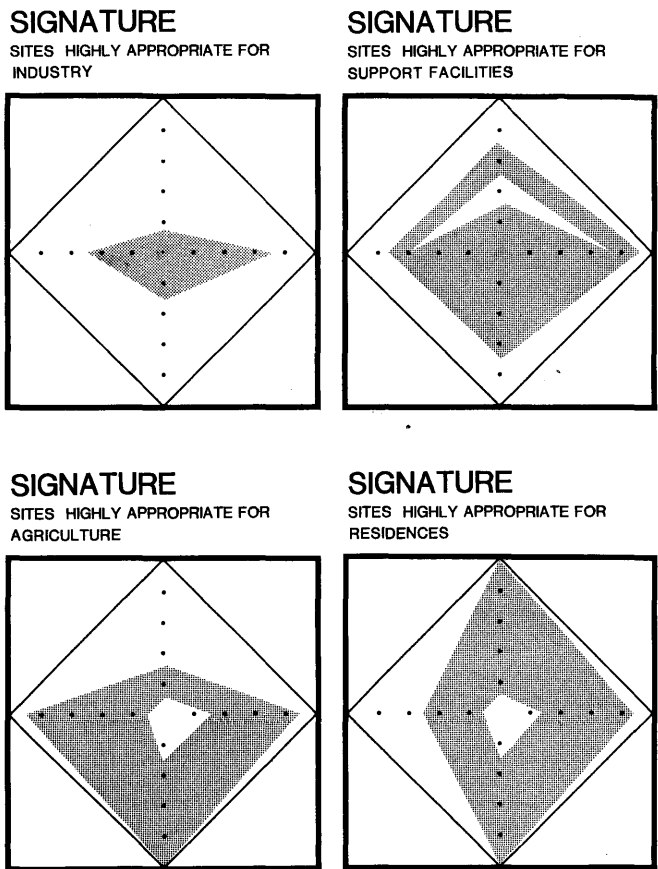

**Figure 3.—Signatures of several other sites along the Roanoke River. There is a pattern of larger site signatures upstream. These are more pristine sites, away from urbanized areas.**

In order to find the sites appropriate for each proposed land use, a second, more detailed questionnaire is circulated. Depending on the complexity of the project, the instrument is either circulated to planning and design professionals in the community or to the community citizens. There is a matrix of questions. The first asks the biological character of a site appropriate for each proposed land use category. The second asks the cultural character appropriate. Desirable aesthetic and physical character make-up the third and fourth questions. The questionnaire is designed so questions are the ordinals which were used to establish the site signature grids. Patterns of response are plotted on a grid congruent to the site signature grid. These are called Land Use Signatures.

**SYNTHESIS**

The synthesis of information is a clear and simple process. To discover whether a site is appropriate for a particular land use, the Land Use Signature is overlaid with the Site Signature. If the corner points of the Site Signature fall within the shaded area of the Land Use Signature, the site is appropriate for the land use. If the proposed land use will be innappropriately sited, the incompatible dimensions are immediately visible. The decision can be traced in the score sheet to landscape characteristics. Traceability is a welcome benefit of the method.



**Figure 4.—Several Land Use Signatures for the Roanoke River Project.**

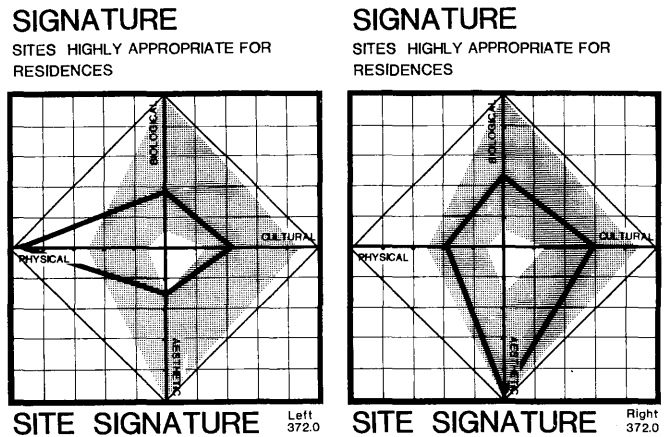

**Figure 5.—Site Right 372.0 is appropriate for residences. The physical character of the site across river rules it out for the same land use.**

A graphic synthesis is performed for the entire river corridor, crossing each Site Signature with each Land Use Signature. Some sites will be appropriate for almost all land uses, some for one or two, some only for preservation. The product of this exercise is the flexible Land Suitability Plan.

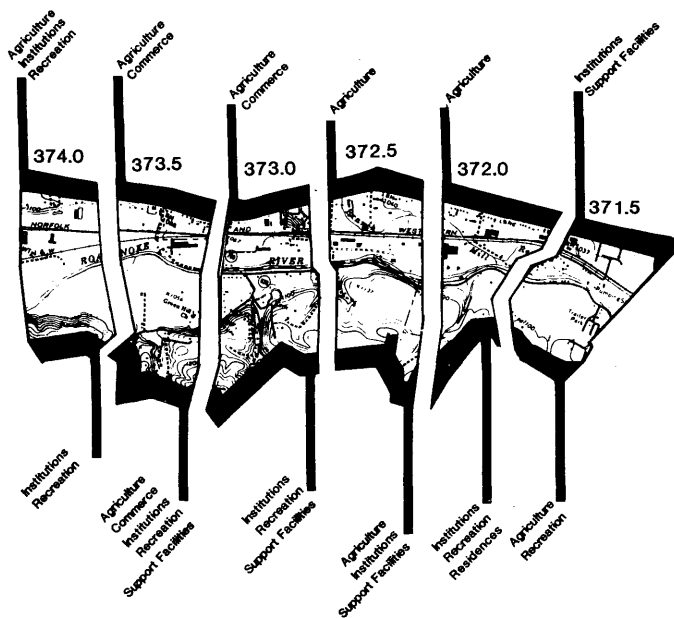

Figure 6.—Portion of the Land Suitability Plan for the Roanoke River Corridor.

### DESIGN EVALUATION

The last part of the Site Signature Method is the Design Evaluation. The Planning Commission or similar body of the jurisdiction can use this simple tool to control proposed development in the river corridor. In the Virginia Statutes, (15.1-863) there is a clause which allows jurisdictions to "divide their jurisdictions into districts for the purpose of applying different building codes requirements. (Blair, 1969)." This allows jurisdictions to establish the River Corridor Zone. Within the River Corridor Zone, multiple land uses are permitted as long as they can be built in accordance with both the conventional standards established for land uses throughout the jurisdiction (setbacks, etc.) and the performance criteria of the River Corridor Zone.

When implemented, the flexible Land Suitability Plan alone is not sufficient control over the land use of the river corridor. Although a site is "zoned" for any land use that appears on the LSP, in order to be built, the proposed land use must meet the performance criteria derived from the conditions of the desired site. By using site plan reviews, the Planning Commission requires a developer to sift his proposed development through the Land Suitability Plan (first, coarse sieve). The design evaluation is the second, fine mesh sieve a proposed development must pass before it can be built.

Conditions of the landscape are noted in each dimension of the study. They describe the health of sites. Unique features, the diversity of features, fragile features are noted, as well as all characteristics that have been encroached upon. For instance, a unique biological condition may be the "existence of a threatened species." A unique cultural condition may be "an historical landmark,"

etc. Each site has a distinct palette of different conditions. The conditions of the example site are noted with asterisks in figure 2.

According to the Land Suitability Plan, institutions, recreation, and residences may be located on the example site. In order to be constructed, the chosen land use(s) must have minimum impact on the noted conditions. Given the incentive for higher potential profit, a developer can afford to invest in a sound design which will perform to these site specific standards.

PROPOSED LAND USE \_\_\_\_\_

SITE RIGHT BANK - 372.0

LOCATION RIVERSIDE DRIVE @ S.R. 694

APPROPRIATE LAND USES INSTITUTIONS, RECREATION, RESIDENCES

PROPOSAL \_\_\_\_\_

EVALUATOR \_\_\_\_\_

DATE \_\_\_\_\_

### RIVER CORRIDOR DESIGN EVALUATION

CHARACTERISTIC	CRITERIA	NOTES
* UNIQUE HABITATS	No construction in delineated areas. Potential indirect impact is determined by expert at preliminary review.	
RIVER & RIPARIAN STRIP	Only those activities which are inseparable from river water use are allowed within 100' of bank.	
SWALES	Design must not interrupt established vegetative cover. Construction breaks are to be replanted in accordance with tree ordinance.	
FRAGILE HABITATS	Erosion & Sedimentation Control Plan required. Zero Net Runoff Formula, Zero Net Non-point Source Pollution Formula required.	
ACCESS TO RIVER	Public easement access required in 100' Riparian Strip.	
* ARCHAEOLOGICAL SITES	Virginia Center for Archaeological Research is to be notified and allowed access to all threshold sites for 7 year interim period before site disturbance.	
HISTORICAL/CULTURAL SITES	Options determined at preliminary site plan review.	
* UNIQUE IMAGEABILITY	Design must perform to Imageability Formula.	
* LANDSCAPE VIEWS & QUALITY OF IMAGES	Noted landmarks shall not be blocked from the viewpoint of the riparian strip. Before/After impact sketches required at final review.	
* ENCROACHMENT OF INTEGRITY	Encroaching elements are to be removed from the fundus before issuance of certificate of occupancy.	
* WATER QUALITY	All Projects—Zero Net Non-point Source Pollution Formula.	
* FLOODPLAIN	Structures floodlined to currents of 151/2. Construction must leave No net change in flood elevation. No habitable floors below 100 yr. Flood Elev.	
* EROSION	All Projects—Executed in accordance with Virginia Erosion & Sedimentation Control Standards.	
SEPTIC SUITABILITY	Septic Tanks prohibited above the major groundwater recharge zone.	
PERFORMANCE SUITABILITY	Refer to Soil Survey for preliminary performance predictions.	
NO. 1 ZONE	Zero Net Runoff Formula.	

APPROVAL: \_\_\_\_\_

PRELIMINARY \_\_\_\_\_

FINAL \_\_\_\_\_

Figure 7.—A Design Evaluation Sheet set up for the conditions of the example site. The example site has five special requirements beyond those of the conventional code.

Even though allowed by the LSP, the prospect of mitigating some potential land uses with the difficult conditions of some sites will be either physically or financially impossible, thus preserving them. Other sites will have few or no difficult constraints posed by site conditions, and can be developed intensively. The above figure shows how the method directly transfers "is" statements to "Thou shalt" statements. Proposed designs perform to existing stable amenities by passing impact formulae or by avoiding fragile areas.

Plan review and advice by experts is arranged for evaluation of rapidly changing or extremely fragile criteria. This will assist the developer, who sometimes has little knowledge of the requirements of the social and natural landscape, but has an ability to recognize the cost of dealing with the legislated constraints posed by some sites. More importantly, this will assist the local planning body, for discretionary controls require informed and defensible decisions. Ofcourse, all sitesheets and design requirements must be available to the public, so Site Signature Method assessments must be in a tight, implementable package. The studies are detailed, decisions are traceable, and the product can be reproduced.

The Site Signature Method is proposed as a performance based zoning methodology for sensible location and sensitive construction of multiple land uses in fragile environments. Site specific criteria require that construction in the river corridor fit the environmental conditions, rather than the sometimes arbitrary conditions posed by conventional prescriptive zoning manuals. Land planning decisions are tied to the existing landscape character. Currently, this method has not smoothly tied the multiple land uses to each other. This suitability concern has been incorporated as an addendum into the evaluation stage of proposed projects. To improve this method, adjacent land use compatibility needs to be considered in the inventory stage.

Although in the developmental stages, the Site Signature Method serves as a medium between the developer, scientist and constituent by addressing the concerns of each. By employing the medium, the landscape can be developed without loss of biological, cultural, aesthetic or physical resources. This "site specific zoning" results in an appropriately developed landscape which celebrates the character of the river corridor.

#### LITERATURE CITED

- Blair, Frederick H. 1969. Toward a Regulatory System: For Use, Occupancy and Construction. Planning Advisory Service Report #243. Chicago: A.S.P.O.
- Hill, David P. 1984. The Site Signature Method of Land Suitability Planning and the Roanoke River Reclamation Project. Blacksburg, Va.: David P. Hill.
- Jones, Grant and R. Jones. 1973. Nooksack. Seattle, Wash.: Jones and Jones, Inc.
- Meshenberg, Michael J. 1976. The Administration of Flexible Zoning Techniques. Planning Advisory Service Report #318. Chicago: A.S.P.O.

# Strategic Riparian Resource Management in a Metropolitan Setting: The Minnesota Valley Experience<sup>1</sup>

Tim Kelly 2

---

Abstract.--Riparian lands in metropolitan areas are often under extreme pressure to accommodate conflicting uses. Strategic management planning provides a method for mediating conflicts, and developing realistic objectives. This paper discusses the performance, pitfalls, and potential of the strategic management effort for the Minnesota Valley National Wildlife Refuge and Recreation Area.

---

## INTRODUCTION

Effective Management of Riparian lands often suffers from the manner in which the planning for those lands is done (Bailey, 1982). The perspective taken is that it is not the plans that are bad, necessarily, but it is the way plans are done that could stand improving. The bias here is that doing planning "right" is more important than making a technically correct plan.

Planning techniques and analytical formats for resource management decisions are available in profusion - models, simulations, standards, etc. They could stand further technical refinements, surely, but line management performance is often little affected by doing so (King, 1972).

Techniques often have an unhappy way of seeking an application. They can become solutions looking for problems. The result is often either a plan that collects dust on the shelf or one that is overly rational, where all possible actions are guided toward predetermined goals. The paralysis of analysis thereby creeps in.

A weakness of such an approach to planning and management is that it may not make

allowance for unexpected developments and thereby not allow managers of riparian lands to act in the most opportune ways.

## Planning Hierarchy

One approach useful in resolving this problem is to distinguish three levels of planning. The first level is product design planning (planning for the type, extent, complexity and apparentness of facilities or modifications to the resource). The second level involves operational planning (planning for capital, labor, and application of technical programs such as burning or visitor information). The third level is strategic planning (planning for the uncertainties and constraints facing a management effort).

Product design and operation plans are specialized, narrowly focused plans. They may detail methods and goals that largely are given with such constraints as site capability, personnel availability, engineering specifications and program prescriptions. As a result these plans are often detailed and quite complex. In strategic planning, the constants for these two previous planning efforts become variables which direct and potentially change the way the agency pursues its basic mission; however, operations and the products they oversee, is the way the mission is pursued.

## Strategic Management Planning

It should not be assumed that the strategic plan is the arithmetic sum or five year extrapolation of particular product and operation plans. Strategic management planning is a different planning process, with very different purposes, constraints and givens - and hence different inputs from those of functional plans. Strategic management planning involves identifying key issues which relate to

---

1 Paper presented at the Riparian Ecosystems and their Management Conference [Tucson, Ariz., April 16-18, 1985].

2 Senior Planner, Natural Resource Planning, Minnesota Department of Natural Resources, St. Paul, Mn. Many people have been helpful in developing the ideas for this paper, most notably, Julie Kelly, Glenn Radde, Brian Stenquist, and Paul Swenson of the Minn. DNR; Ed Crozier and Jim Lutey of the U.S. FWS; and Arnie Stefferud of the Metropolitan Council.

the capability of operational activities and product areas to succeed, so that those activities can be related to the physical, social, and managerial environments in which they exist (Steiner, 1979).

There are four elements to a strategic management situation which must be addressed either explicitly or implicitly for strategic planning to yield effective results (Steiner, 1979). These are the expectations of the major interests outside of the organization, the expectations of the major interests inside the organization, the history, condition and trend of the resource as it relates to management performance, and the organizational strengths/weaknesses, and the opportunities/threats in its environment. If one of these elements is missing, the management system created by the plan will not operate effectively. The result will be confusion and/or skepticism on the part of management and the public.

This paper reviews and analyzes the strategic management planning effort for the Minnesota Valley National Wildlife Refuge and Recreation Area in light of these four elements. It should be pointed out, however, that in reality the planning process was iterative, involving continual back and forth analysis.

#### PROJECT SETTING

The Minnesota Valley National Wildlife Refuge and Recreation Area was established in 1976 to recognize the values of wildlife habitat preservation, environmental education and close-to-home recreation (P.L. 94-466). The area involves 19,110 acres along the lower 36 miles of the Minnesota River.

The Flood Plain of the Minnesota contains an almost continuous belt of type III and IV wetlands and shallow lakes, as well as wet prairie and floodplain forest. More than two million people in the Minneapolis-St. Paul Metropolitan area live within a half-hour of the refuge and recreation area. The sixteen management units involve 38 government units including four counties and nine municipalities. The U.S. Fish and Wildlife Service and the Minnesota Department of Natural Resources were the lead agencies charged with developing a plan to guide future land use and management of the valley.

#### A FOUR STEP STRATEGIC MANAGEMENT AUDIT

##### Public Expectations

A first step in the planning process involved assessing public perceptions and attitudes toward the refuge and recreation area. This effort focused on three objectives. First, that the two lead agencies planning the refuge and recreation area were acting within their proper powers and responsibilities.

Second, that the proposed courses of action responded to the interests and values involved, and that tradeoffs were reasonably fair. Third, that credible two-way communication between the project and the various interests was established in order to find ways to mediate and negotiate problem issues.

Conservation efforts in the lower Minnesota River Valley have a long history of citizen involvement. Both the state trail and the refuge/recreation area were initiated and carried through the legislative process by citizen organizations. A number of private interests such as private hunt clubs, stables and nature centers have been involved in promoting and taking advantage of the recreational and wildland potential of the area. Most of the economic activity involves sand and gravel extraction, barge transportation of grain, and development.

In total over 225 meetings and workshops were held with individuals, groups and the public. Support for the project focused on the desire for public access and use, preservation of wildlife habitat, and the continuation of traditional uses such as hunting and trapping. Expectations and attitudes resistant to the refuge and recreation area concept were the potential loss of family farms, the lock up of exploitable sand and gravel resources, and potential restrictions on residential and commercial development.

##### Agency Perspectives

An essential step to developing effective strategy is also determining the interests of key managers and administrators within the management framework. Many of these values can not be evaluated quantitatively or logically but do influence basic long range aims and objectives of an agency or program. One of the most important elements in the planning process of the valley was coordination of the counties and municipalities. Local government exerts the most direct influence over the land uses of the valley. Without their assistance, the incremental effect of land use development decisions could make management of project lands for wildlife or recreation impossible. In addition the amount of coordination and cooperation required within and between agencies required contact with key people within the two lead agencies. In the final analysis support for the project took the form of agreement that something should be done to protect the natural character of the valley. Opposing this was resistance to a project that was very different from traditional wildlife refuges and state parks in its shape and required administration.

##### Management Performance and Trends

The third element in developing effective strategy is an assessment about past performance, the current situation and trends affecting management. The abundance of



wildlife in the valley has been noted as far back as the 1830's. Inventories and surveys have recorded approximately 50 species of mammals and 100 species of birds resident to the valley. Approximately 275 species have been counted during migration, twenty-two of them waterfowl. Aerial surveys have counted up to 40,000 waterfowl during fall migration and twenty-six whitetail deer per square mile.

The recreational significance of the valley dates back to the early 1900's and the establishment of some of the gun clubs in the valley. The 1960's saw the establishment of 3,200 acre Fort Snelling State Park, the 72 mile 9,000 acre Minnesota Valley Trail and the designation of the river as a state canoe and boating route. Considerable acquisition took place in the valley during this time for state facilities, as well as local and regional parks and open space. Combined with protective regulatory programs such as shoreland zoning, the state protected waters program, and the federal 404 program, approximately sixty percent of the refuge and recreation area involved at least some public interest. The recreational opportunities of the valley occur in what could be called natural urban and rural settings. An extremely high number of scenic, natural, and historic attributes combined with extensive areas of natural vegetation and screening from the river bluffs provide both real and perceived opportunities for feelings of remoteness.

The trends for both wildlife and recreation were characterized by an increasing need for opportunity combined with an, increasing pressure to utilize lands for commercial purposes. This general trend is expected to continue.

#### Strategic Capability

An assessment of the strategic management situation of the valley involved identifying favorable and unfavorable situations affecting the project and the capability of the management organization to deal with them.

The planning process surfaced five opportunities to establish, and enhance the management of the refuge/recreation area. First, was the planning process. By creating a planning team with federal, state and local involvement, the potential for cooperation, and coordination, was maximized. Second, the local units of government involved in the project were in the process of completing comprehensive plans of their own on which future zoning and development decisions would be made. Third, the boundaries of the refuge/recreation area had excluded the major commercial and industrial areas of the valley, which highlighted the opportunity and the need to cluster those uses. Fourth, the valley is dominated by the Minnesota river. The natural floodplain and wetlands that occur there provide a necessary buffer and storage basin for flooding. Fifth, the project enjoyed

considerable support from citizen groups on the river.

The planning process surfaced four threats which could adversely affect the refuge/recreation area. They were declining water quality from the springs and seeps which feed the lakes and fens of the area. Exclusion of federal and state lands from regional land use policy, resulting in an inability to enforce detrimental changes in local planning and zoning. The nonconforming nature of the state's lands in the valley with existing state recreation land classification which could potentially lead to an inability to fund state projects, and finally, the complex and nontraditional character of the project which often lead to a resistance to change from traditional administrative policies.

The planning process was able to draw on four strengths to deal with these situations. First the planning process was able to tap and utilize the vision, intuition and networking abilities of the state and federal managers. Their ability to soften the internal resistance to the complexities of the project and gain needed contacts with and perspectives on the local political environment, and land use situation was essential. Second, the involvement of federal, state and local governments in the planning process provided a more complete picture of the potential techniques and programs which could be used to complete the project, such as the metropolitan surface water management program, and the state critical area program. Third, the strong citizen support provided a resource that if organized could support the project through political initiative. Fourth, local, state and federal managers were, for the most part, able to consider and adopt techniques such as performance zoning and transfer of development rights, to provide opportunities for both the conservation of riparian lands and economic development.

Countering these capabilities were two serious weaknesses. First, the lack of federal funding to complete acquisition of the refuge and second, the absence of a formal policy on the state and regional levels that recognizes the significance of the refuge/recreation area so that coordination is required between local, state and federal activities.

#### ENVIRONMENT AND STRATEGY

Strategic management involves relating the management organization to its external forces. Broadly speaking, external forces create the environment within which missions will be pursued, change will occur, and choice must be made. The external forces may then be viewed in terms of the physical, social and managerial settings. From a strategic perspective, the crux of an environmental analysis is to determine what external opportunities and constraints face management goals. Strategy

formulation addresses a set of dimensions which attempt to coordinate and form a logical fit between those goals and the external forces. The essence of successful strategy is to find the right opportunity and utilize the strengths available to the organization to pursue it (Steiner, 1979).

The basic strategy in place in the Minnesota Valley is a joint venture between federal, state and local governments. The coordination and cooperation achieved during the planning process provide for flexibility and innovation in pursuing goals, permits informality and initiative on the part of the agencies involved, and allows for rapid response to problems and changes in priorities. The method advocated in the plan for linking the different agencies is a tier system of plans and zoning ordinances at the municipal, county and regional levels. These local plans are to be consistent with the basic goals and standards for performance detailed in the plan for the valley. To date, all of the local units of government have recognized the refuge and recreation area in their comprehensive plans and approximately half have adopted some type of protective zoning in the form of shoreland or sensitive land zoning.

This arrangement does have it's strategic pitfalls, however. The success of the management system is critically dependent on the leadership of a few key managers. Line staff must be flexible and willing to assume different responsibilities and address different sorts of problems than those found on traditional refuges and recreation resources. Authority relationships are constantly changing, leading to problems of dual command and functional coordination, and finally, the flexibility and informality provided by a joint venture can lead to too much independence by the involved agencies and a breakdown in interagency coordination.

The strategic management effort of the Minnesota Valley has encountered all of these pitfalls and has coped with them through vigilance, a commitment to transforming the social and cultural setting of land management. The primary tools have been "jawboning", networking and an underlying philosophy which focuses on the production of opportunities and the performance of natural systems and settings. The management guidelines have been in the form of performance standards. By establishing thresholds and parameters for natural and recreation systems, the opportunity exists to develop policies that are empirically based, and defensible in terms of the health, safety and welfare of the public. The result places managers on the offensive and able to respond to changes in the strategic environment. Examples in use in the Minnesota Valley are the recreation opportunity spectrum and performance zoning for sensitive lands such as wetlands and floodplains (Brown, Driver and McConnell, 1978, Thurow, Toner and Erly, 1975).

## CONCLUSION

The underlying premise of this paper is that strategic planning is a management tool which should be undertaken either implicitly or explicitly by agencies and individuals involved in riparian resource management. Too frequently, with the daily need for problem solving, managers are compelled to focus solely on the operational level. The need is to keep the crises of yesterday and today in perspective so that the opportunities of tomorrow can be recognized. If managers are not constantly looking for new opportunities and favorable situations affecting their mission, there can be no progress toward "reconciling conflicting uses", or positively managing riparian lands. Therefore, a regular strategic planning session could keep the forward momentum going.

The strategy in effect on the Minnesota Valley National Wildlife Refuge and Recreation Area is currently being reviewed as part of the Metropolitan River Corridors Study. The study's purpose is to recommend policies and actions to optimize the recreational, fish and wildlife, historic, natural, scientific, scenic and cultural values of the Mississippi, Minnesota, and St. Croix rivers within the Minneapolis and St. Paul metropolitan area (P.L.96-607). Research for the study implies that the current strategy for the Minnesota Valley does not offer long term insurance for protecting the resources of the valley. While the study will not be complete until June, 1985, the data and capability does exist to address the four strategic elements discussed earlier and effectively mediate the institutional and policy differences that exist in the management environment of the valley. This is essential if the project is to have a future.

Strategic planning, however, is not deciding what to do in the future, it is deciding what to do now in order to deal with the future. In view of this, planning can not be the responsibility of some unit tucked away in a dark corner at headquarters. Too often planning is assigned to an individual who is "in charge of planning", what ever that means. Unfortunately the designee is usually a staff member who "coordinates" or "leads" the planning effort. Planning is a process, not an effort. It can not be effective if done by staff invulnerable to the risk of failure. The onus to plan lies with each unit manager, the line person responsible for driving an activity forward. The planning function is only responsible for giving form and shape to managements objectives.

This is not to say that there isn't a need for planners in an organization. The task of giving expression to managements opportunities, and how they are going to be tackled is not a static process. It is an essential element in the iterative process which brings out the inconsistencies of thinking, and pulls together the different perspectives and contributions of

the disciplines reporting to the unit manager. This is needed so that a coherent view of the mission and the path being followed is shared by the management team.

I started this paper with the statement that the way plans are done could stand improvement. I conclude by highlighting the need for management to understand the different levels of planning, their relationship and their place of order. Finally, managers should decide to plan strategically, because the plan is the decision which directs the way a mission will be pursued and provides a reference point to judge what's happening in the total managerial environment. If you don't have a reference point you can't make evaluations and judgements on progress or a change in the course of management. On the other hand, if you don't care where you are going, any road will get you there.

#### LITERATURE CITED

- Bailey, James A. 1982. Implications of "Muddling Through" for Wildlife Management. *Wildlife Society Bulletin* 10(4):363-369.
- Brown, P.J., B.L. Driver and C. McConnell 1978. The Opportunity Spectrum Concept and Behavioral Information in Outdoor Recreation Resource Supply Inventories: Background and Application. p.73-84. In Integrated Inventories of Renewable Natural Resources: Proceedings of the Workshop. [Tucson, Ariz., Jan.8-12,1978] USDA Forest Service General Technical Report RM-55, 482p. Rocky Mountain Forest and Range Experiment Station, Ft. Collins, Colo.
- Ginn, Richard H. and James H. Burbank 1978. Protecting Riparian Ecosystems from Competing Urban Pressures-The Swan Creek Experience. p.207-215. In *Strategies for Protection and Management of Floodplain Wetlands and Other Riparian Ecosystems: Proceedings of the National Symposium.* [Pine Mountain, Georgia, Dec. 11-13,1978].
- King, David A. 1972. Towards More Effective Natural Resource Planning. p.260-267. In *Transactions of the Thirty-seventh North American Wildlife and Natural Resource Conference.* [March 12-15,1972] Wildlife Management Institute, Washington D.C.
- Steiner, George A. 1979. *Strategic Planning: What Every Manager Must Know.* 338p. Macmillan Publishing Co., Inc., New York, N.Y.
- Thurrow, Charles, William Toner and Duncan Erly 1975. *Performance Controls for Sensitive Lands.* The Planning Advisory Service, 156p. American Society of Planning Officials. Chicago. 111
- U.S. Laws, Statutes, etc. 1976. The Minnesota Valley National Wildlife Refuge Act of 1976. An act providing for a national wildlife refuge in the Minnesota river valley. Public Law 94-466. In it's United States statutes at large. 1976. 90 Stat. 1992 (16 USC 668) U.S. Gov. Print. Off., Washington D.C.
- U.S. Laws, Statutes, etc. 1980. National Park System Amendments of 1980. An act providing for a committee to study the the preservation, enhancement, protection, and use of the designated recreation, park, open space and historic sites along the Mississippi, Minnesota and St.Croix rivers within the Twin Cities metropolitan area. Title IX, Public Law 96-607. In it's United States statutes at large. 1980. 96 Stat. 1520 U.S. Gov. Print. Off., Washington D.C.

# Research Issues in Riparian Landscape Planning<sup>1</sup>

Kerry J. Dawson<sup>2</sup> and Gregory E. Sutter<sup>3</sup>

---

Abstract--A Riparian reserve has been established on the UC Davis campus. The 80-acre Putah Creek Reserve offers the opportunity to research issues related to the typically-leveed floodways that increasingly flow through California's agricultural landscape. Explored is the integration of issues related to research, education, conservation, recreation and flood control.

---

## INTRODUCTION

A Riparian Landscape Research Laboratory has recently been established on the campus of the University of California at Davis. The laboratory is a campus reserve located in the leveed floodway of Putah Creek, a major stream of the California central valley flowing from Lake Berryessa in the coast range to the Sacramento River's Yolo by-pass. The Putah Creek Campus Reserve is over four miles long, contains over 80 acres of University property, and has a flood control capacity of 80,000 CFS. With over 90% of California's native riparian landscape lost, this reserve offers the opportunity to research many planning issues related to the pressures placed upon the limited, typically leveed, riparian floodways that continue to flow through the state's agricultural landscape. A planning and research master plan is in the process of being completed on Putah Creek which outlines the role of the reserve for education, research, habitat preservation, recreation, and flood control. Of particular interest for recreation in the master plan is the continued quality of the area as a campus greenbelt. The master plan also encourages and expands educational activity. The major emphasis of the master plan and this paper, however, is the research program which is being established to study the integration of conservation versus development objectives.

## HISTORICAL SETTING

Putah Creek originates within the eastern slopes of the California Coast Range. It drains a 576 square mile watershed in this chaparral

<sup>1</sup>Paper presented at the first North American Conference "Riparian Ecosystems and Their Management; Reconciling Conflicting Uses," the University of Arizona, Tucson, Arizona, April 16-18, 1985.

<sup>2</sup>Associate Professor, Department of Environmental Design, University of California, Davis, California 95616.

<sup>3</sup>Graduate Student, Biological Ecology, University of California, Davis, California 95616.

covered, sedimentary rock, mountainous area before beginning it's 30 mile-long meander across the flat central valley of California. The historical and natural terminus of the creek was a series of wetlands and seepage pits located just west of the Sacramento River (Figure 1). The historical flow pattern of Putah Creek was a torrential flow in the wet winter months with little or no flow in the late summer. It is highly unlikely that water even reached the UC Davis Campus in the dry season.<sup>4</sup>

Like most biotic systems in California, adjacent land uses have had a large impact on the structure of Putah Creek. The City of Davis (first known as Davisville) developed in the middle of the central valley around the railroads along what is now the University Arboretum. The city was periodically flooded by high flows from the creek and in 1872, the city decided to alleviate the problem by relocating the portion of the creek which flowed through the city to a new channel farther south. The relocation of the channel altered the slope of the drainage and caused incision to take place upstream of the new channel. The result of these activities left the reserve channel with steep banks and extensive riparian vegetation at the west end. In the 1940's, to further protect the surrounding agricultural areas from flooding, the U.S. Army Corp of Engineers added levees to the lower sections of the creek. This resulted in a broad, flat banked, manmade channel with leveed boundaries on the east end of the reserve (Figure 2).

In the late 1950's the Bureau of Reclamation chose the steep coast range valley of Putah Creek for the site of its Solano Project reservoir. The completion of Monticello Dam in the early 1960's created Lake Berryessa. This project stored much of the winter runoff of Putah Creek for later release into irrigation canals. Downstream of the project near UC Davis, reserve peak flows have been

---

<sup>4</sup>Garcia, Jose, 1923, "A Report on Putah Creek as a Source of Water Supply for the Irrigation Lands in the Sacramento Valley." M.S. Thesis, University of California, Berkeley, p. 11.

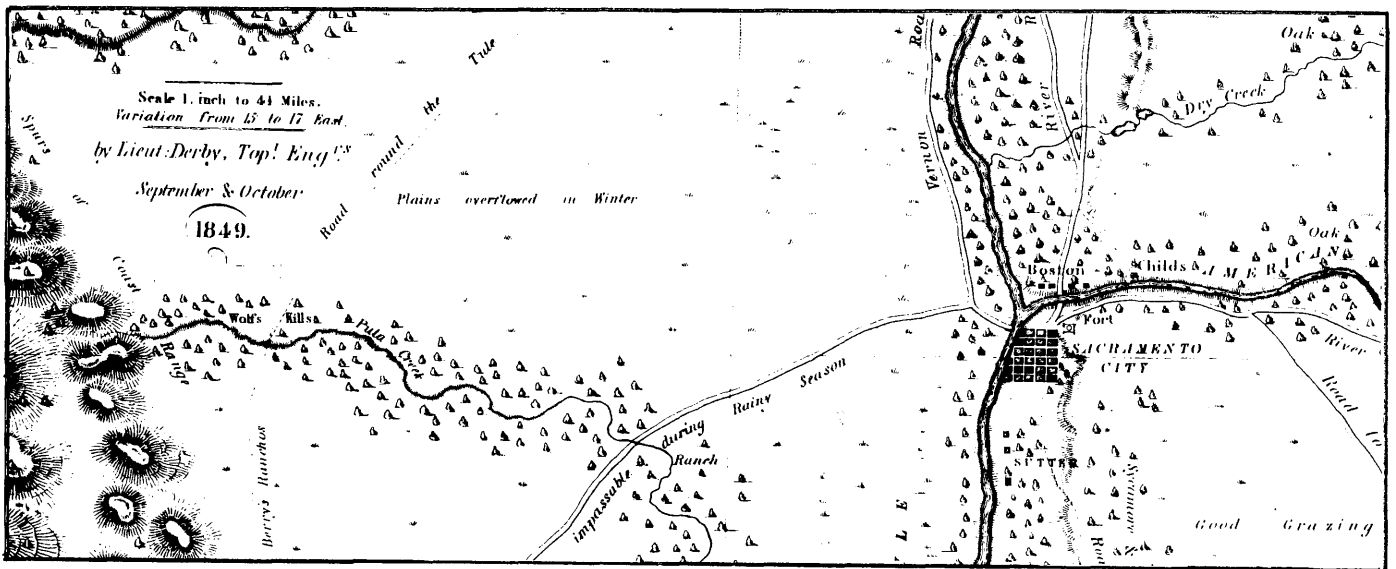

Figure 1--Originally a large riparian forest was located along Putah Creek. Historically the flow pattern had high winter flows and little or no summer flows.

reduced from a maximum of 80,000 CFS to 40,000. In addition, year round flows now occur with summer flows legally maintained at a minimum of 5 CFS.

#### PRESENT CONDITIONS

Although the University of California owns the preserve, it is within a floodway managed by the State Department of Water Resources. It is this agency's responsibility to maintain the floodway capacity of the creek at adequate levels. Traditionally it is the practice of the flood control agencies to inspect the stream channels and remove debris and vegetative growth which they feel will restrict capacity of the floodway. With this objective in mind in 1949 the entire channel was cleared of vegetation from winters to the creeks terminus at the Yolo bypass. Additional clearing

activities have taken place since then along smaller sections of the creek on a five to seven year rotation.

Because the construction of Monticello Dam has substantially decreased the expected flood flows in the floodway, it has been agreed that certain vegetative growth will be allowed in the stream to compensate for this flood flow reduction. When vegetation removal is necessary in the preserve area, the State Department of Water Resources has agreed to work with the reserve management committee on the timing, type, and location of vegetation removed.

Despite the fact that Putah Creek has been severely altered from it's pristine condition, it still represents an environmental corridor of significant importance to riparian dependents. Through the history of the central valley wildlife has been greatly reduced as agricultural development became more intensive. Remaining riparian systems like Putah Creek retain much of the riparian vegetation present in the valley and represent critical shelter and habitat for riparian dependents. Because only a small percentage of California's original riparian forest remains, remnant systems (even those degraded by man), are important to retain and reestablish. Three critical avian species which still find habitat in the Putah Creek Reserve include the Yellow Billed Cuckoo, Coccyzus americanus, the Inyo Brown Towhee, Pipilo fuscus, and the Swainson's Hawk, Buteo swainson.

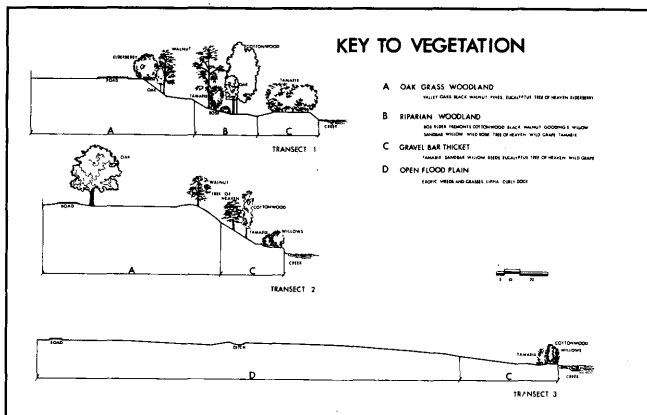

Figure 2--The banks of Putah Creek at the west end of the reserve are steep with extensive vegetation. Conversely the east end has broad, shallow grassy banks. This variation is schematically shown in the cross sections above.

#### PLANNING ISSUES

In 1984 the senior landscape architecture students of the University of California at Davis did an analysis of the new Putah Creek Reserve as part of their fall studio. The students began initial resource inventories, identified key

issues and prepared draft management plans for the reserve. The Putah Creek management committee is utilizing the student work as a basis for further analysis in their efforts to prepare a final management plan for the reserve. The committee has identified several key issues which must be addressed by the campus reserve master plan in order for the Putah Creek reserve to ultimately meet the goals affixed to it as a university reserve. These issues all revolve around the multiple use concept and the land use conflicts inherently involved with that concept. The issues can be grouped into five main categories: education, recreation, riparian habitat preservation, flood control, and research.

Currently, the reserve is underutilized educationally. The community occasionally utilizes the creek for dog training sessions, native basket weaving classes, and a day camp in the summer but the creek is seldom used for university instruction. A goal for the reserve is to create additional structured and unstructured educational opportunities through facility development and signage.

The reserve has been utilized for a widely diverse range of recreational activities. These activities include walking, jogging, picnicing, horse riding, swimming, boating, fishing, use of firearms, and off-road vehicle use (Figure 3). Although educational, recreational and other uses of the reserve can conflict, the management committee has generally been successful in addressing these issues by either eliminating undesirable uses or by locating uses so that conflicts are minimized.

The main hurdle which the preserve management committee is now facing is how to integrate the flood control objectives of the reserve with the riparian habitat preservation, educational and other goals of the reserve in one viable plan. The management committee reviewed the objectives



Figure 4--Despite the noise of busy interstate 80 the cottonwood trees west of the highway are used as a nesting sight by several pairs of the endangered Swainsons Hawk.

set up for these major functions. The following are examples of identified research questions which must be addressed and solutions found in order for the Putah Creek reserve to fully realize it's potential:

- What are the specific impacts of vegetation on the floodway capacity in the Putah Creek Reserve? i.e. exactly how much vegetation should be removed and at what locations?
- Do large tree specimens really pose a threat to levee and bridge facilities or do they overcome this negative aspect with positive aspects such as bank and soil stabilization.
- Is it possible to selectively remove vegetation and reduce the roughness coefficient to

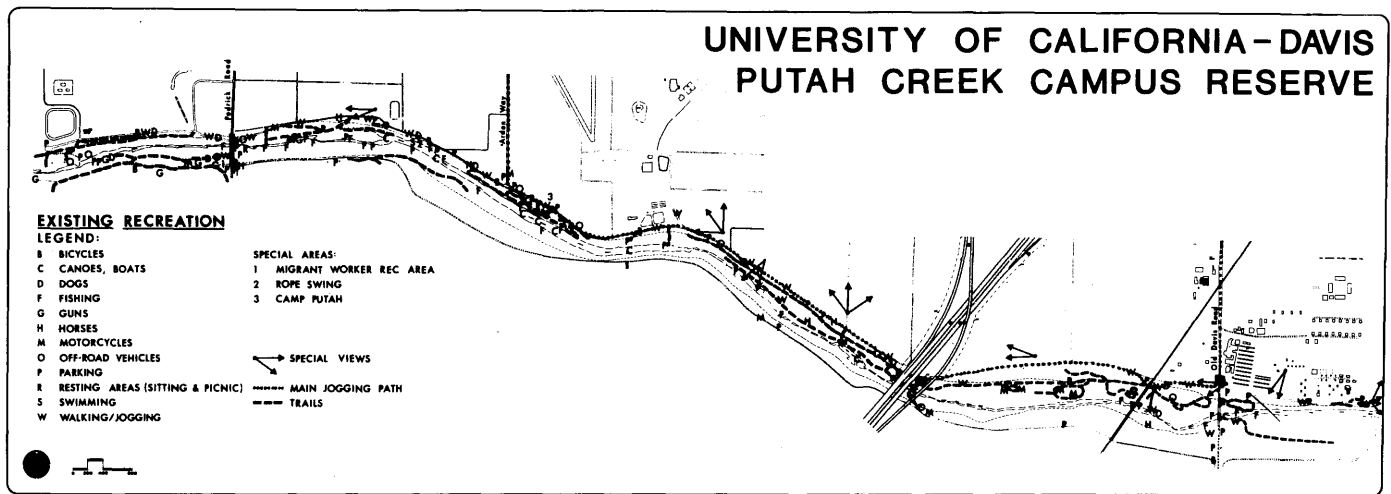

Figure 3--The Putah Creek Reserve is utilized for a wide variety of recreational uses. Because of the multiple use nature of the reserve, some of these uses will be accommodated in the master plan. Others may have to be eliminated due to conflicts with uses of higher priority.

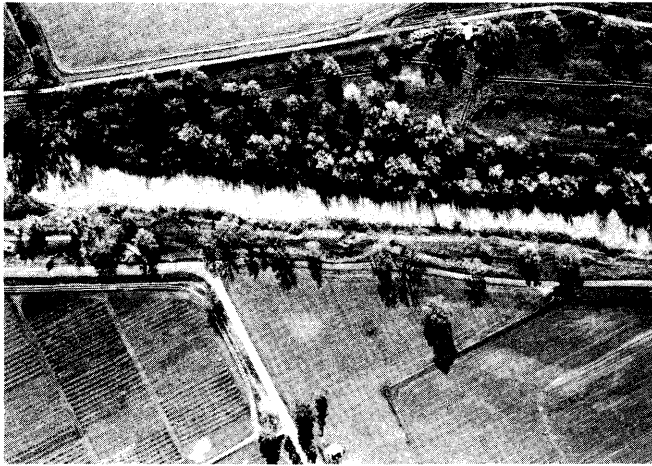

Figure 5--Agricultural land uses border Putah Creek on both the north and south. Yet within the levee roads significant riparian vegetation exists.

an adequate level while at the same time increasing diversity and habitat.

- What techniques exist for exotic plant species control and native species reestablishment?

- Where in the creek do fish spawn and what are the impacts of university gravel removal on these spawning sites.

#### ISSUES SURVEY

After defining the research subject areas which are specifically critical to the successful management of Putah Creek as a Riparian reserve within a floodway, it was decided that the opinions of other professional managers and scientists who are dealing with the same issue would be useful. Through a survey the research needs for the management of floodway riparian systems in the west could more clearly be identified and thus a priority of research in the Putah Creek reserve could be established which would more directly address the needs of managers throughout the state of California and western U.S.

The survey was sent to the participants and attendants at the 1977 and 1981 California Riparian Systems Conferences<sup>5</sup> and the participants at the 1977 Symposium on the "Importance Preservation and Management of Riparian Habitat" held in Tucson Arizona.<sup>6</sup>

453 surveys were sent out and approximately 125 were returned. Each participant in the survey was asked to rank the following list of research issues according to their perception of the need for research in that area.

- A Effects of artificial hydrologic variation on the ecology of riparian systems.
- B Effects of channel structure and floodway design on the ecology of riparian systems.

- C Channel and levee management and maintenance issues.
- D Relationships of channel vegetation to flood flows.
- E Life histories of native terrestrial riparian flora and fauna.
- F Life histories of native aquatic riparian flora and fauna.
- G Life histories of native riparian invertebrates.
- H Relationship of water quality to cultural and ecological goals.
- I Studies in the biogeography of riparian areas and corridors.
- J Comparisons of natural riparian systems and "altered" riparian systems.
- K Impact of exotic flora and fauna on native riparian systems.
- L Techniques for exotic species control and management.
- M Techniques for native species reestablishment and management.
- N Habitat modeling for riparian landscape restoration.
- O Riparian/upland wildlife interaction.
- P Impacts of historic land use related to current riparian system structure.
- Q Impacts of timber and mining expansion on riparian systems.
- R Impacts of agricultural expansion on riparian systems.
- S Impacts of urban expansion on riparian systems.
- T Impacts of infrastructural expansion (utility easements, storm water outfalls, roadways, etc.) and riparian systems.
- U Recreation, open space, aesthetic values of riparian systems.
- V Archaeological, historical, and ethno-botanical values of riparian areas.
- W Legal aspects of riparian systems.
- X Economic values of riparian systems.

Figure 7 illustrates the results of the issues survey. Generally speaking the average response of the survey participants did not vary greatly among the different research issues. As one respondent comments "All of these are important issues. What we need the most is more research funds." The two issues of greatest concern to the participants were the effects of artificial hydrologic variation and the effects of channel structure and floodway design on the ecology of riparian systems. Techniques for exotic species control and native species reestablishment also ranked as high priority research issues.

#### CONCLUSIONS

With over 90% of the original riparian systems of California completely eliminated the remaining "altered" systems represent environmental corridors of significant value to conservation. Many of

<sup>5</sup>Sands, Anne; editor, 1977, "Riparian Forests in California Their Ecology and Conservation," proceedings of a symposium sponsored by the Institute of Ecology and the Davis Audubon Society, held May 14 at UC Davis.

<sup>5</sup>Warner, Richard E. and Kathleen M. Hendrix, editors 1984, "California Riparian Systems, Ecology, Conservation and Productive Management," Proceeding of the California Riparian Systems Conference held September 17-19, 1981 at UC Davis.

<sup>6</sup>Johnson, R. Roy and Dale A. Jones, editors 1977, "Importance, Preservation and Management of Riparian Habitat," proceedings of a symposium, held July 9, 1977 at Tucson, Arizona.



Figure 6--800 C.Y. Of gravel are currently removed each year from the creek bed. Yet it is not known if this has a negative or positive impact on the fish spawning activities.

these altered systems have the potential to expand in value if an effort is made to actively restore them.

The key to the success of improving the habitat value of these systems is researching floodway management alternatives which use an integrated approach. These alternatives must

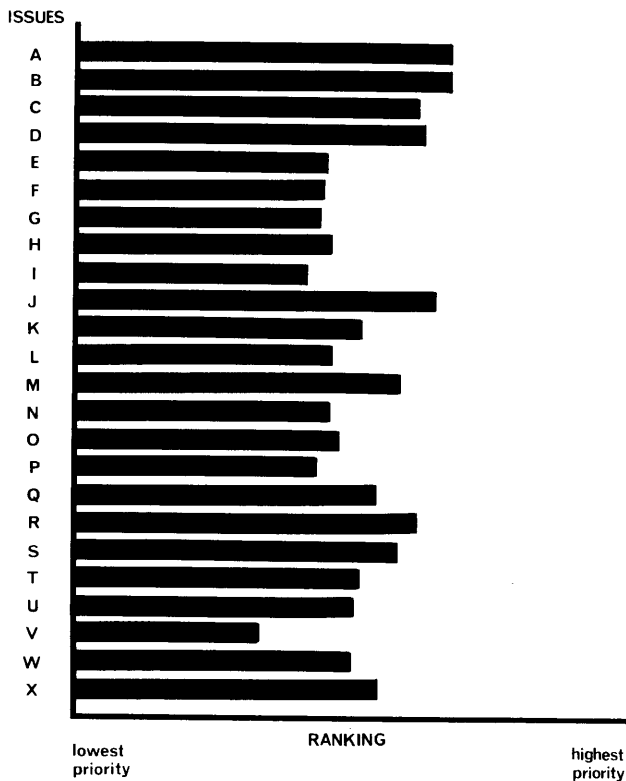

Figure 7--The bar chart illustrates the mean ranking of the research issues by the survey respondents. Overall there is very little variation in the responses to the different issues.

include cultural objectives such as flood protection but also can include objectives for conservation if intelligent planning occurs. This is the major goal that the Putah Creek Management Committee has for the University Reserve.

#### REFERENCES

- Carter, Lee W. and Gene L. Anderson. 1984. Riparian Vegetation on Flood Control Project Levees: Constraints and Opportunities. In Proceedings of the California Riparian Systems Conference, Richard E. Warner and Kathleen M. Hendrix editors, (University of California, Davis, September 17-19, 1981), pp. 548-550.
- Dawson, K. J. 1983. Recreational management for newly established natural areas. In Proceedings of the 48th North American Wildlife Conference, Kansas City. pp. 544-550.
- Dawson, Kerry J. 1984. Planting Design Inventory Techniques for Modeling the Restoration of Native Landscapes. In Proceeding of the California Riparian Systems Conference, Richard E. Warner and Kathleen M. Hendrix editors, (University of California, Davis, September 17-19, 1981), pp. 465-470.
- Hallberg, Donald L. and Gene R. Trapp. 1984. Gray Fox Temporal and Spacial Activity in a Riparian/Agricultural Zone in California's Central Valley. In Proceedings of the California Riparian Systems Conference, Richard E. Warner and Kathleen M. Hendrix editors, (University of California, Davis, September 17-19, 1981), pp. 920-928.
- Johnson, R. Roy and Dale A. Jones, editors. 1977. Proceedings of a Symposium: Importance, Preservation and Management of Riparian Habitat. (Tucson, Arizona, July 9, 1977), USDA Forest Service General Technical Report RM-43.
- Martin, Kenneth E. 1984. Recreation Planning as a tool to restore and Protect Riparian Systems. In Proceedings of the California Riparian Systems Conference, Richard E. Warner and Kathleen M. Hendrix editors, (University of California, Davis, September 17-19, 1981), pp. 748-756.
- Sands, Anne, editor. 1977. Proceedings of a Symposium: Riparian Forests in California, Their Ecology and Conservation (University of California, Davis, May 14, 1977). Institute of Ecology, Publication #15.
- Schlorff, Ronald W. and Peter H. Bloom. 1984. Importance of Riparian Systems to Nesting Swainson's Hawks in the Central Valley of California. In Proceedings of the California Riparian Systems Conference. Richard E. Warner and Kathleen M. Hendrix, editors, (University of California, Davis, September 17-19, 1981), pp. 612-618.



# The Value of Riparian Habitat and Wildlife to the Residents of a Rapidly Urbanizing Community<sup>1</sup>

S. Black, P. Broadhurst, J. Hightower and S. Schauman<sup>2</sup>

---

Abstract.--The values of residents were tested by two surveys. The first established the community's knowledge of and preference for riparian habitat and wildlife. The second survey established the position of the specific values found in the first survey among the broader range of human values. Results show that residents value natural habitat, which suggests important policy implications for the management of urban water systems.

---

## INTRODUCTION

This paper is a result of investigations into public attitudes toward wildlife habitat in Bellevue, Washington, a city juxtaposed between the Cascade Mountains 30 miles east of Seattle and Puget Sound 10 miles west.

Two pilot studies were conducted on Kelsey Creek, a riparian habitat in this rapidly urbanizing area of the Puget Sound basin. In 1975, the City of Bellevue decided to improve an existing natural creek system to carry surface storm drainage. Eight areas were acquired on the creek for storm water retention, and eight retention structures were installed for maintaining the water at existing levels.

These retention areas are maintained in the native vegetation and now help preserve the habitat value of the creek to wildlife. Since that time, the population of the area has approximately doubled.

The neighborhoods on the creek vary from lower middle income to upper income. Average education, according to the 1980 census is 15.74 years and the great majority of residences abutting the creek are single family homes. An estimated 80% of Kelsey Creek's 15 mile length is under private ownership.

The objective of Study A was to determine how people feel about the wildlife they encounter along Kelsey Creek, whether they can identify species and their likely habitats, and what interaction the residents seek with this wildlife. The objective of Study B was to place the

results from this survey in a broader context of human values.

## PREVIOUS STUDIES

At a 1974 symposium, *Wildlife in an Urbanizing Environment*, Ann Dagg reported people's reactions to urban wildlife. Stating that a person's attitude is closely correlated with his interest in and knowledge of wild animals, she surveyed how knowledgeable urban residents were about animals. Similarly, the Kelsey Creek Survey developed a photo-survey to test resident's knowledge of local urban wildlife and riparian habitat.

Frederick Gilbert, in *Public Attitudes towards Urban Wildlife* (1982), finds that the local environment of an urban dweller impacts his perception on proportion to its naturalness and accessibility. The proximity of natural areas was found to be important in simulating residents to view wildlife. The Kelsey Creek Study investigated the significance of riparian natural areas to urban dwellers.

Ronald Dick (1982) tested public interaction with wildlife in urban parks. Dick found wildlife an added bonus to activities for which the park was originally either intended or entered, and called it an "amenity resource" for the park experience. His label for wildlife in a park setting is "aesthetic recreational resource." This new terminology helped the Kelsey Creek team interpret results.

This way of interpreting results is in contrast to Stephen Kellert's views (1984). Kellert states that a person's response to wildlife is determined by a specific personality trait. Ronald Dick's study (1982) is the only work cited from this region.

---

<sup>1</sup>Paper presented at the First North American Riparian Conference, *Riparian Ecosystems and Their Management: Reconciling Conflicting Uses*, April 16-18, 1985, Tucson, Arizona.

<sup>2</sup>Black, Broadhurst, and Hightower are students, Schauman is Associate Professor and Chair, Department of Landscape Architecture, University of Washington, Seattle.

## METHODOLOGY AND RESULTS

Two Kelsey Creek pilot studies were conducted in autumn and winter 1984-1985. A photo

survey of landscape types showing six different local landscape features on Kelsey Creek's edge was the first part of the Survey A (Table 1). The landscape types ranged from completely natural with no human impact to a highly managed golf course and a highly stylized landscape, a Japanese-style garden.

PHOTO TYPE	RESPONSE :				
	A	B	C	D	E
NATURAL RIPARIAN	1	2	2	9	12
ORNAMENTAL RIPARIAN	2	3	1	8	13
GOLF COURSE RIPARIAN	3	2	4	11	5
ORNAMENTAL RIP. (japanese)	1	2	3	4	16
MARSH RIPARIAN	3	4	6	6	6
PART NATURAL PART IMPACTED	6	4	11	4	2

Table 1 Preference response to phototype by sample

Where:

- A = Dislike a lot
- B = Dislike somewhat
- C = Neutral
- D = Like somewhat
- E = Like a lot

Results show that residents recognized habitat value in the landscape for two species, a racoon and a robin. This recognition also correlated with the absence of any human evidence in the photograph at all. Conversely, when asked where they themselves would most like to live, the overwhelming response was for the Japanese-style landscape showing the greatest and most 'idealized' landscape management approach. Their most preferred landscape type, however, was a natural wild area with a fallen log across the creek.

Survey A then tested animal identification. Ten pictures were selected from a book on north-west wildlife and birds. The pictures were chosen for their neutrality in presenting endearing features of pictured wildlife, and all animals shown were known to reside on Kelsey Creek.

Eighty-seven percent of the respondents recognized all species but only 20% named them by their specific names. This reflects the experience of F. Gilbert in the Guelph study. The final part of the first survey was a questionnaire designed to be a combination of closed-ended, scaled response and preference questions.

A few general conclusions could be drawn from this survey: the residents were consistent in their knowledge, sentiment and actions with respect to wildlife and have a generic understanding of animal habitat needs. Residents find wild animals both appealing and intrinsically important, and seek them as neighbors. The majority would like to see more animals in their yards, but understand that urbanization has already diminished the chances of this happening. When asked to compare trivial everyday problems with potentially annoying interactive events with wildlife, residents uniformly indicated a preference for interaction with wildlife. Animals mentioned in the survey by residents included coyotes, raccoons, rabbit, possum, birds, quail, duck, weasel, salmon, trout, geese, blue heron and squirrel. In light of wide publicity Pacific Northwest to "Save the Salmon," it is interesting to note that only a small percentage of people mentioned them.

Survey B was designed to correct for some of the halo effect necessarily a factor in Survey A by comparing the relative importance of wildlife and habitat to other human values. Residents both in single family and apartments were surveyed at varying distances from the creek to establish the relative importance of proximity to the creek and awareness of its riparian population and habitat.

The proportions of the sample housing type was chosen to reflect census data for the area's residential distribution; 75% single family homes, 25% apartment dwellers. The sample for area A owned property abutting the creek. The sample for area B lived in sight of the creek and the sample for area C lived out of sight of the creek (fig. 1).

This survey included a cognitive map survey of the creek and the location of wildlife populations. Kelsey Creek is well marked by

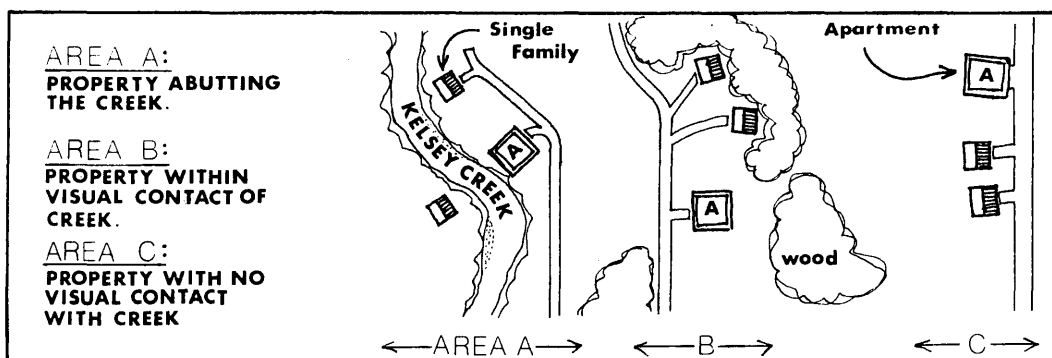

Figure 1.--Illustration showing a typical part of the Survey area.

signs throughout its course. Of the 43 respondents, 25% knew of the creek as a system, 50% related to it only as a part of their neighborhood and 25% related to it at a single location. A second part was added to the cognitive map survey to discover respondents' awareness of the interrelation of wildlife to water edge. Fifty-six percent identified wildlife with either water course or lake edge, 67% related wildlife to the park area on the creek only. For 33%, wildlife had no apparent relation to water at all. Given the large amount of private ownership on the creek, this figure helps substantiate Gilbert's finding that the "public perception of wildlife is modified by the local environment and its 'naturalness and accessibility' (1982, p. 252).

A scaled response questionnaire was designed to relate wildlife and natural areas or habitat to a broader range of human values. Included among the 26 questions were transportation, convenience, quality of schools, neighborhood safety, natural wooded areas, nearby employment, etc. These questions were put into five major categories; Economics, Personal Preference, Neighborhood Quality, Activity Choice and Community Quality.

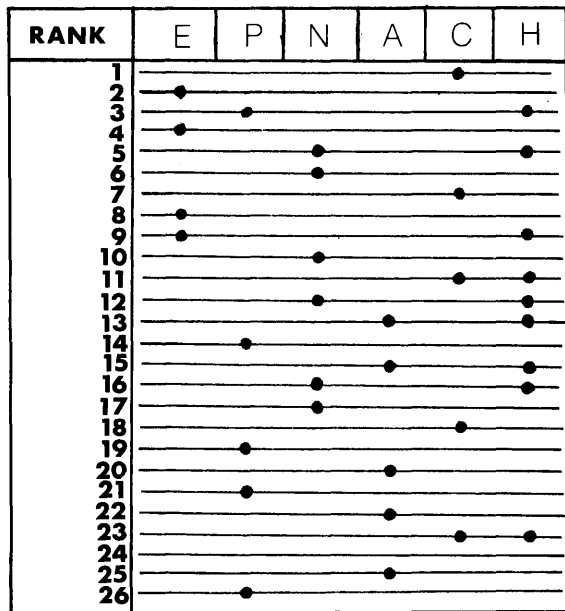

Table 2.--Showing rank of questions by categories.

Where:

- E = Economics
- P = Personal Preference
- N = Neighborhood Quality
- A = Activity Choices
- C = Community Quality
- H = Habitat

Additionally, significant attitude and value differences concerning wildlife and habitat occurred (by the Chi-square test) among residents of single family homes in proportion to the distance that they live from the creek. The residents were more responsive to wildlife along

the riparian corridor. The creekside dwellers had the longest residence and in the open-ended interviews expressed a concern for seasonally returning animals which illustrated a more intimate awareness of life around their homes. Those who lived out of sight of the creek, in area C, were statistically half as attuned to habitat and its attendant wildlife as were those residing in area A.

Apartment dwellers showed no significant differences in attitude toward wildlife and habitat between the three groups tested. One hypothesis for this finding is that they may not regard the land outside their dwellings as their own, and a part of their responsibility.

Of the five major categories of response tested, Neighborhood Quality was the only category showing significance, and this occurred in area A, on creek, and among single family residents.

Rachael Kaplan (1984) has studied the restorative experiences people have both in going into nature and in conceptually thinking about it. The last part of the team's study was an open-ended interview to discover the meaning of the natural environment to the daily lives of Bellevue residents.

Responses were tallied under three groups, those referring to the natural environment positively and in "spiritual" terms (privacy, tranquility, restfulness, etc. were subsumed under this category), those whose motivation for living in this area was primarily spatial, (idealistically motivated by a country/farm image, space for children, animals, etc.), and those whose choice was primarily based on practical realities and ease of life in proximity to workplace, freeway, shopping, and schools. When viewed in this way, no one category received significantly more weight than any other category.

#### CONCLUSIONS AND POLICY IMPLICATIONS

From the above survey results, it is apparent that our sample like animals near their homes, like habitat near their homes, perceive their own habitat as including wildlife, and recognize the relationship between urbanization and habitat loss. The majority recognize a relationship between animals and water. In the overall list of values, country or suburban living, natural wooded areas, and abundant creeks, lakes, and woods ranked equally with safety, transportation and good schools in the top 10 of 26 questions.

This survey can have meaning to riparian ecosystem management in three ways: it suggests that suburban residents prefer small natural areas in the city to miniparks and ornamental trees and lawns. It suggests that planners think about retaining existing riparian habitat as amenity and as a useful means of storm water drainage, also, where appropriate. Finally, it

was evident from this survey that with very little additional information and education, residents in an actively and rapidly urbanizing environment may become the greatest proponents for the maintenance of existing riparian ecosystems within and as an integral part of their communities.

#### LITERATURE CITED

- Craik, K.A., and McKechnie, G.E., ed. 1978. *Personality and the Environment*, Sage Publications, Beverly Hills and London.
- Dagg, A.I. 1974. "Reactions of People to Urban Wildlife," In Noyes and Progulske (1974)--*Wildlife in an Urbanizing Environment*. pp. 163-165.
- Davis, James D. 1974. "Wildlife in Your Back-yard," In Noyes and Progulske (1974)--*Wildlife in an Urbanizing Environment*. pp. 175-177.
- Dick, Ronald Eugene 1982. "An Analysis of Human Response to Contacts with Wildlife in Urban Parks," University of Washington Thesis SD 121 TH 30 347.
- Gilbert, Frederick F. 1982. "Public Attitudes Toward Urban Wildlife: A Pilot Study in Guelph, Ontario," *Wildlife Society Bulletin*. 10:245-253.
- Hender, J.C. and Schoenfield, C. 1973. *Human Dimensions in Wildlife Programs*, Mercury Press, Rockville, Maryland.
- Kaplan, Rachel 1983. "Impact of Urban Nature: a Theoretical Analysis," *Urban Ecology* 8:3189-198.
- Kellert, Stephen 1979. "Public Attitudes Towards Critical Wildlife and Natural Habitat Issues," U.S. Fish and Wildlife Service, Yale School of Forestry.
- Kellert, Stephen 1984. "Urban American Perceptions of Animals and the Natural Environment," *Urban Ecology* 8:209-228.
- Pudelkewicz, Patricia J. 1984. "Visual Response to Urban Wildlife Habitat," Forty-sixth North American Wildlife Conference. 46:381-389.
- Schroeder, Herbert W. and Anderson L.M. 1984. "Perception of Personal Safety in Urban Recreation Sites." *Journal of Leisure Research*, 16: 2 178-194.

#### ACKNOWLEDGEMENTS

Many thanks to Darryll R. Johnson, Project Leader, Social Sciences Program, Cooperative Park Studies Institute, College of Forest Resources, University of Washington and Richard Converse, Research Analyst, Cooperative Park Studies Unit, College of Forest Resources, University of Washington for their insightful help, expertise and interest in our project.

# Public Values for Riparian Ecosystems: Experimental Results in the West and Implications for the Grand Canyon<sup>1</sup>

Philip A. Meyer<sup>2</sup>

---

Abstract.--Economic, psychological and legal arguments for use of compensatory procedures in valuing riparian resource protection and restoration activities are presented. Values from studies of riparian habitat in California and Washington are reported, and implications for economic evaluation of restorative alternatives affecting Grand Canyon considered.

---

## ALTERNATIVE PROCEDURES FOR VALUATION OF PUBLIC RIPARIAN RESOURCES

By public resources, I mean those resources that are publically owned or held, and have not been divided up in private markets. Economists evaluating public riparian habitat have two basic procedural choices. If riparian habitat is to be enhanced beyond normal levels, assessment of respondent's willingness to pay for the improvement is required. Direct survey assessment of willingness to pay, and indirect approaches such as travel cost and hedonic travel cost address the "willingness to pay for enhancement" issue. Procedures are summarized in Dwyer, Kelly and Bowes (1977). If riparian habitat is threatened, or is to be restored to more normal conditions after sustaining prior damage, economists must assess the level of appropriate compensation required to leave respondents as well off as if they had not been damaged. Compensating valuation has proceeded via direct survey of respondents to this date. Prior compensatory studies are summarized by Meyer (1984). The distinction between paying and compensating approaches is based on the economic principal that in any transfer of resources between user groups, gainers should gain enough to compensate losers, whether compensation is paid or not, if the resource shift is to be beneficial for society (Kaldor, 1939; Hicks, 1939). It has more recently been affirmed by a variety of applied contemporary economists (Meyer, 1982; Desvougues, Smith and McGivney, 1983; Huppert, 1983; Knetsch, 1983; Biosystems Analysis, Inc., 1984; Hueth and Niklitschek, 1984).

---

<sup>1</sup>Paper presented at North America Conference on Riparian Ecosystems and their Management, University of Arizona, Tucson, April 17, 1985.

<sup>2</sup>Philip A. Meyer is President, Meyer Resources, Inc., Davis, CA.

In the past, some economists (Willig 1976) argued that while a theoretical distinction between paying and compensating approaches to valuing public goods was clear, as a practical matter, answers via either method came out about the same, and the two approaches could be usually used interchangeably. In the nine years since Willig's article, empirical analysis has made it clear that compensatory values associated with public resource damage or restoration of previous damage are significantly higher than those developed via "paying" approaches (Meyer, 1975; Crutchfield and Schelle, 1978; Meyer, 1979; Bishop and Heberlein, 1979; Rowe d'Arge and Brookshire, 1980; Adams, Currie, Hebert and Shikiar, 1980; Schulze, d'Arge and Brookshire, 1981; Meyer Resources, Inc., 1982; Knetsch, 1983). Psychological expertise has confirmed that such differences are to be expected from alternative framing of public resource valuing procedures (Kahneman and Tversky, 1982). The magnitude of empirical differences is illustrated in a selection of results from comparative work (table 1).

## LEGAL AND INSTITUTIONAL CONSIDERATIONS ASSOCIATED WITH EVALUATION OF RIPARIAN HABITAT

Recent legal developments have lent urgency to the need for proper compensatory evaluation of riparian habitat protection and restoration measures, and have raised a seemingly new issue-associated responsibility of institutions and their experts.

State fish and game agencies, using their respective authorizing legislation, have sought compensation for fish and wildlife damages in a number of cases (Halter and Thomas, 1982). In the recent Mono Lake case (National Audubon Society v. Superior Court, 1983), the concept of common proprietorship may have been further expanded, with concern for public trust apparently coequal with that for private proprietorship. Hueth and Niklitschek (1984) are explicit with respect to the linkages between emerging legal pronouncement and required evaluation

Table 1.--Comparative Responses to Paying and Compensating Approaches for Valuation of Public Resources.

<u>Public Resource</u>	<u>Author</u>	<u>Ratio of Compensating to Paying Values</u>
1. All saltwater fishing within a day's round trip.	Meyer (1975)	19:1
2. Favorite fishing site in a region.	Sinclair (1976)	20:1
3. Elk hunting in Wyoming	Brookshire and Randall (1978)	7:1
4. One acre of Riparian habitat along the Sacramento River.	Meyer Resources, Inc. (1982)	5:1
5. Wetland hunting in an area.	Hammack and Brown (1974)	4:1
6. Statewide goose hunting for one year.	Bishop and Heberlein (1979)	2:1 to 5:1
7. Washington ocean fishing.	Crutchfield and Schelle (1978)	4:1
8. Fishing in a park.	Eby (1975)	3.5:1
9. One day of recreation along the Sacramento River.	Meyer Resources, Inc. (1982)	4:1 to 5:1
10. Local postal service.	Banford (1977)	4:1
11. Fishing pier.	Banford (1977)	3:1

procedure for public resources -- and in the context of other recent legal initiative.

The purpose of this paper is to examine the different evaluation procedures which might be used for projects intended to mitigate past fishery losses, rather than to enhance production on the Columbia system. The need for this work stems from passage of the Pacific Northwest Electric Power Conservation Act of 1980, which directed the Northwest Power Planning Council to "promptly develop and adopt pursuant to this subsection a program to protect, mitigate, and enhance fish and wildlife...on the Columbia River and its tributaries" (Section 4H1a). Subsequently, the Northwest Power Planning Council has established the 1953, pre-McNary Dam run level as the reference point for mitigation and enhancement projects which are mandated by the Act....

In general, economic evaluation procedures change as the institutional environment changes. The viewpoint of this paper is that passage of the Act and establishment of pre-McNary run size as goals for fishery runs has given the potential beneficiaries of increases in runs a right to fish production up to the levels established by the Council. Until such levels have been attained, whether by on-site or off-site projects,

no distinction needs to be made between enhancement and mitigation projects. The term enhancement is meaningless, and all projects can properly be regarded as mitigating past losses, until pre-McNary Dam run levels have been restored. (p. 93).

Such legal perspective and related economic assessments would seem to compel proper compensatory evaluation of restorative alternatives affecting riparian habitat. To proceed otherwise may render agencies and experts vulnerable not only to criticism on the basis of economic theory, but to legal challenge and possible liability (Honour Brown v. U.S.A., 1984).

#### EMPIRICAL EVIDENCE CONCERNING COMPENSATORY VALUES FOR RIPARIAN HABITAT

This section reports on two studies providing initial data on the value of riparian habitat. The first study, conducted for the California Resources Agency, surveyed residents of Sacramento and Colusa, California to develop "fair compensatory values" for riparian habitat along the Sacramento River (Meyer Resources, Inc. 1982). The second study, conducted with Biosystems Analysis, Inc. for the Bonneville Power Administration developed ecologically based economic values for old growth Douglas fir forest in Western Washington state (Biosystems Analysis, Inc.; 1983). These data are preliminary, and revised estimates based upon further theoretical

modification recently completed by the author are expected to render them somewhat conservative. They are based on direct evaluation of habitat as it supports a variety of nature-based activities and interests. Details for each analysis can be obtained from the indicated source documents. Annual value per acre, and total present value per acre are displayed in table 2.

Table 2.--Per Acre Preliminary Value Estimates for Riparian Habitat.

	Annual Value	Total Present Value <sup>1</sup>
	-----\$ per Acre-----	
<b>A. Sacramento River Riparian Habitat</b>		
1. Thirty-foot leave strip along the river bank.	1,663	52,549
2. Full riparian between set back levies.	3,625	114,546
<b>B. Old Growth Douglas Fir Forest in Western Washington</b>		
3. Based on estimate of 1,362 330,000 acres of old growth still remaining in Western Washington.	1,362	43,038
4. Based on a hypothetical reduction in remaining total acreage to 230,000 acres.	2,929	92,553
5. Based on a hypothetical reduction in remaining total acreage to 64,000 acres.	10,680	337,476

<sup>1</sup>Total present value is calculated at 3 percent rate of discount. Some agencies confuse interest rates with discount rates, and use a higher discount rate. We concur with the increasing use of 3 percent by federal and state agencies in the energy field, and use it here. A theoretical discussion of discounting issues is found in Lind et. al. (1982).

The economic value of riparian habitat will vary with habitat type and quality, with the total amount of riparian habitat generally available and with other local circumstance. These values do possess a relative degree of comparability, however, and will serve as initial estimates until further work can be completed.

THE RELEVANCE OF REQUIRED ECONOMIC VALUING  
PROCEDURES FOR RIPARIAN RESOURCES  
IN THE GRAND CANYON

In conclusion, it seems appropriate at this Arizona conference, to reflect on the implications developed here for economic value work associated with riparian habitat in Grand Canyon National Park. Such comments appear timely. In 1963, completion of a hydro-electric peaking facility at Glen Canyon resulted in flows sometimes going from 3,000 to 25,000 cfs. in a 24 hour period. This has degraded recreation use conditions both on the Colorado River and along its banks, with attendant impact, one would suspect, on riparian communities. In response to these concerns, the U.S. Bureau of Reclamation, in association with the National Park Service advertised in 1984 to conduct a Grand Canyon Recreation Study (USBR, 1984). One of the purposes of this study was to estimate the economic value of public activities based upon the riverine and riparian features of the Canyon, presumably for use in evaluating alternative flow regimes to restore ecological and recreational viability along the river. Instructions identified that only a "willingness to pay" approach to evaluation could be used, however, thus preempting the greater part of any economic value that might be developed. Originating authors may have believed that they were proceeding with whatever technology was available. It is clear from the information provided here, however, and from empirical results concerning the economic value of riparian and related resources developed elsewhere, that willingness to pay evaluation of restorative improvements in Grand Canyon National Park are not consistent with economic theory and may also not be consistent with legal obligation. More importantly, they are likely to develop values that significantly underestimate the public's interest in restoration of riparian capabilities in the Grand Canyon, relative to alternative more appropriate valuing procedures that are available. Thus, while applauding the initiative of agencies who are moving forward to address the issue of restoring riparian habitat and other river-based opportunity in the Grand Canyon, I call upon them to review their program, and make such mid-course corrections as may be necessary to expand its scope to include a full and comprehensive evaluation of the restorative opportunities at hand.

LITERATURE CITED

Adams, R.C., J.W. Currie, J.A. Hebert and R. Shikar. 1980. The visual aesthetic impact of alternative closed cycle cooling systems. Battelle-Pacific Northwest Laboratory.

Banford, Nancy. 1977. Willingness to pay and compensation needed: valuation of pier and postal service. Unpublished paper, Simon Fraser University, Vancouver.

Biosystems Analysis, Inc. 1984. Methods for valuation of environmental costs and benefits of hydroelectric facilities. Report to Bonneville Power Administration, DOE/BP-266.

- Bishop, Richard C. and Thomas A. Heberlein. 1979. Measuring values of extra-market goods: are indirect measures biased? *American Journal of Agricultural Economics* 61-5, December.
- Brookshire, David S. and Alan J. Randall. 1978. Public Policy alternatives, public goods and contingent valuation mechanisms. Resource and Environmental Economics Laboratory, University of Wyoming, Laramie.
- Crutchfield, James A. and Kurt Schelle. 1978. On economic analysis of Washington ocean recreational salmon fishing with particular emphasis on the role played by the charter vessel industry. Department of Economics, University of Washington, Seattle.
- Desvougues, William K., V. Kerry Smith and Matthew P. McGivney. 1983. A comparison of alternative approaches for estimating recreation and related benefits of water quality improvements. Research Triangle Institute, EPA 230-05-83-001, Triangle Park, N.C.
- Dwyer, John F., John R. Kelly and Michael D. Bowes. 1977. Improved procedures for valuation of the contribution of recreation to national economic development. University of Illinois, Urbana-Champaign.
- Eby, Philip A. 1975. The value of outdoor recreation; a case study. Master Thesis, University of British Columbia, Vancouver.
- Halter, Faith and Joel T. Thomas. 1982. Recovery of damages by States for fish and wildlife losses caused by pollution. *Ecology Law Quarterly*, 10-5.
- Hammack, Judd and Gardner M. Brown. 1974. Waterfowl and wetlands: toward bioeconomic analysis. Johns Hopkins University Press, Baltimore.
- Hicks, John R. 1939. The foundations of welfare economics. *Economic Journal*, 49-699.
- Honour Brown v. U.S.A. 1984. U.S. District Court of Mass. 81-168-T.
- Hueth, Darrell L. and Mario Niklitschek. 1984. Mitigation and enhancement project evaluation procedures for salmon and steelhead fish runs on the Columbia river system. *In*, Making economic information more useful for salmon and steelhead production decisions. NOAA Technical Memorandum NMFS F/NWR-8.
- Huppert, Daniel D. 1983. NMFS guidelines on economic evaluation of marine recreational fishing. NOAA Technical Memorandum NMFS-SWFC-32.
- Kahneman, Daniel and Amos Tversky. 1979. Prospect theory: an analysis of decision under risk. *Econometrica*, 49-263.
- Kaldor, Nicholas. 1939. Welfare propositions of economics and interpersonal comparisons of utility. *Economic Journal*, 49-549.
- Knetsch, Jack L. 1983. Property rights and compensation. Butterworths, Seattle.
- Lind, Robert C., Kenneth J. Arrow, Gordon R. Corey, Partha Dasgupta, Amartya K. Sen, Thomas Stauffer, Joseph E. Stiglitz, J.A. Stockfish and Robert Wilson. 1982. Discounting for time and risk in energy policy. *Resources the Future*, Washington, D.C.
- Meyer, Philip A. 1975. A comparison of direct questioning methods of obtaining dollar values for public recreation and preservation. Environment Canada, Vancouver.
- \_\_\_\_\_. 1979. Publicly vested values for fish and wildlife: criteria in economic welfare and interface with the law. *Land Economics* 55 (May).
- \_\_\_\_\_. 1982. Net economic values for salmon and steelhead from the Columbia river system. NOAA Technical Memorandum NMFS F/NWR-3.
- \_\_\_\_\_. 1984. A survey of existing information to include social or non-market values that are useful for salmon and steelhead management decisions. *In*, NOAA Technical Memorandum NMFS F/NWR-8.
- Meyer Resources, Inc. 1982. Economic valuation of river projects-values for fish, wildlife and riparian resources. Report to the California Resources Agency, Sacramento.
- National Audubon Society v. Superior Court. 1983. 33 Cal. 3d, 419.
- Rowe, R.D., Ralph C. d'Arge and David S. Brookshire. 1980. On experiment on the economic value of visibility. *J. Environmental Economics and Management*, 7-1.
- Schulze, William D., Ralph d'Arge and David S. Brookshire. 1981. Valuing environmental commodities: some recent experiments. *Land Economics*, 58-151.
- Sinclair, William F. 1978. The economic and social impact of the Kemaro II hydroelectric project on British Columbia's fisheries resources. Department of Fisheries and Oceans, Vancouver.
- U.S. Bureau of Reclamation. 1984. Solicitation for Grand Canyon recreation study. Sol. No. 4-SP-40-01780.
- Willig, Robert D. 1976. Consumer's surplus without apology. *American Economic Review*, 66 (Sept.).



# Improving Riparian Protection by Linking State Programs<sup>1</sup>

Michael Mantell, Philip Metzger, and Christine Reid<sup>2</sup>

---

Abstract.--All elements of the riparian setting--river flow, flora and fauna--are essential to maintain healthy riparian ecosystems. Yet the few state legal and institutional regimes to protect riparian habitats and streamflows are fragmented. Protection programs must be made more effective, better coordinated, and informed by more complete data.

---

Riparian plants and animals are an important component of riverine ecosystems. They enhance water quality and aquatic habitat, protect against erosion, and provide food and nesting areas for a host of important species.

The importance of riparian habitat, however, has not been reflected in state legal and administrative initiatives. Only a few tax incentives and wetland protection schemes have been adopted to protect riparian habitat. States throughout the country have developed a broad array of measures to protect instream flow, flood-prone lands and scenic rivers, and some incidental benefits accrue to riparian habitat through these initiatives. But most if not all such protection measures give inadequate attention to the relationship among flow levels, land uses, and riparian habitat -- in other words, to the fact that a combination of land and water resources is necessary to sustain riparian ecosystems. Riparian habitat largely has fallen through the cracks of state resource programs.

While the federal government has taken a variety of steps-- for example, by designating parks, wildlife refuges, and scenic rivers, regulating wetlands and water quality, and protecting reserved water rights and endangered species--to protect riparian lands and water resources, this paper looks at state initiatives, which ultimately will be central to safeguarding riparian habitat. State instream flow provisions and riparian land measures are examined, and shortcomings of each are assessed. The paper concludes by suggesting a variety of ways that these efforts can be strengthened, including means to forge closer links among them.

## STATE PROGRAMS TO PROTECT INSTREAM FLOW

One component of state riparian habitat protection is provided by programs to safeguard in-

---

<sup>1</sup>Paper presented at the North American Riparian Conference. (University of Arizona, Tucson, April 16-18, 1985).

<sup>2</sup>Michael Mantell, Philip Metzger and Christine Reid are Senior Associate, Associate and Research Fellow, respectively, The Conservation Foundation, Washington, D.C.

stream flow. Until recently, all state systems of western water law required that, to gain water rights, water must be diverted off-stream for specified beneficial uses (that did not include instream flow protection). With protection of instream flow as such still in its infancy and somewhat tenuous in practice, the quantification of flow needs has focused on the stream itself to the exclusion of adjacent, riparian concerns.

## Methods to Protect Instream Flow

The techniques that states can adopt to protect instream flows can be divided into three distinct categories. One, **indirect protection of flow**, involves state agency review of the effect on instream resources of new appropriation permits, water quality regulations, and state or basin water plans, and though useful, its efficacy depends largely on the transient presence of committed agency personnel rather than on a statutory commitment that will last through times of controversy and shortage. (Tarlock 1978) Two, the **public trust doctrine** is a court-enforced principle of public law that can preempt existing water rights to limit the ability of state or local governments to dispose of certain water and related land resources. Because its remedy of displacing rights is so severe, the doctrine is likely to be used only in instances where there is a major public interest in instream flow. (Sax 1981)

The third category, **direct set-aside of rights**, includes the three most widely effective techniques: appropriation of water rights, state reservation of unappropriated flows, and establishment of minimum flows in streams by state agencies. (Tarlock 1978, Huffman 1980) By placing instream flow within the existing system of water rights, specific quantities of instream flows can be defined--by state or private ownership of rights, regulation, or both--and secured in an institutional structure that can withstand future conflicts. (Thompson 1981)

The three "set-aside" techniques rely almost exclusively on unappropriated flows and thus largely are devices enabling the state to maintain the instream status quo. The principal characteristic that seems to determine when and where each technique is used is the extent of unappropriated water

available for instream uses. Reservations of flow and establishment of minimum stream levels have been used in relatively well-watered parts of Montana, Washington, Idaho, and Oregon, where large amounts of flow can be set aside without displacing any present water users.

The direct appropriation of water has been authorized in Colorado (for state agencies) and Arizona, two arid states with essentially full appropriation of most reliable flows below stream headwaters. These appropriations do protect flows directly on the few streams bypassed by the states' long history of water appropriation, but, equally important, allow agencies or organizations holding instream rights to intervene in other users' proceedings to transfer water rights, especially into other basins. As one commentator noted, in fully appropriated states, "water transfers will ultimately be of greater importance" than new appropriations. (Kimsey 1975)

The fish and wildlife agencies do not themselves make the final decisions on their proposals to safeguard instream flow, and thus political limits are placed on the exercise of their administrative discretion. In the principal western states with programs or authorities to protect instream flow--Oregon, Colorado, Montana, Washington, Arizona, and Montana--wildlife agency proposals for minimum or base flows or for instream appropriations must be reviewed and approved by separate water boards or resource agencies. (Huffman 1980, Scribner 1979) In Idaho, the state legislature must ratify minimum flow proposals. (Huffman 1980) Thus, the wildlife agency effectively is compelled to consult closely with the permit, reservation, or flow granting body before formally seeking protection of flow.

#### **Problems With Programs to Protect Instream Flow**

Typically, instream flow schemes fail to include in their flow calculations the needs of riparian communities. Even when stream flow recommendations intended to maintain a certain discharge level for fish do to some extent benefit riparian vegetation, they often are set too low to sufficiently water that vegetation because their aim is to protect aquatic life. (Schmidt 1983, Harwood 1981) Instream flow protection should also but does not recognize the critical importance of riparian habitat to terrestrial and avian wildlife, as well as the intrinsic importance of the diverse plant life it sustains.

Another weakness shared in practice by all set-aside approaches is the difficulty of turning paper rights into real instream water. This requires a sophisticated monitoring system to detect overuse, and enforcement must be effective and swift once overuse is found. But monitoring and enforcement are weak in practice because of the high cost of monitoring, the scarcity of state personnel, and the low priority generally accorded to instream flow protection. In Washington, for example, the Departments of Fisheries and Game must request a public hearing before the Department of Ecology can enforce minimum flows against overap-

propriating users--a slow process that is of little benefit to fish stranded in low flow streams. The enforcement problem is especially acute where off-stream users have made appropriations junior to the state's minimum flows (as in Oregon, Idaho, and Washington), and in shortage periods either clamor to have the instream flows suspended or, more often, simply ignored. (Sherton 1981)

Eventually, the competition for water will force states to monitor all water use more closely and enforce instream rights more fully. Until then, the main function of many instream flow programs will be to establish a legal and institutional foothold for instream values, which will become more of a reality as the technical means and political will to assert those values emerge.

#### **STATE PROGRAMS TO PROTECT RIPARIAN LANDS**

With one notable exception--Oregon--states do not have specific, comprehensive programs to protect riparian habitat. Oregon uses a variety of tax incentives, along with a requirement for local inventories as part of its comprehensive land planning, to encourage the improvement of important riparian habitats. Among the most prominent approaches that states take to conserve riparian lands are those measures that deal with wetlands, floodplains, and river conservation--all sites integral to the preservation of riparian habitat.

#### **Methods to protect riparian lands**

##### **Wetlands**

Several states have established programs for controlling development that may harm wetlands. Because of development pressures and the impetus of the federal Coastal Zone Management Act, coastal wetlands have received more attention from state programs than inland wetlands, although activity in inland, freshwater areas has increased.

As of 1984, 11 states had measures specifically related to protection of inland wetlands. (Kusler 1984, Ketwig 1984). These programs vary widely from state to state. Statutes generally provide for state standards for local government regulation or, in a few cases, for direct state regulation. Wisconsin and Minnesota, for example, require local governments to regulate inland shorelands (including rivers), up to 300 feet from the high water mark or the landward side of the floodplain. (Kusler 1980). Several states condition wetland development permits on mitigation of impacts on wildlife habitat or rare plants and animals. A few areas have authorized income or property tax credits for wetland and open space preservation. (Kusler 1984)

##### **Floodplain protection**

At least 30 states control uses of flood-prone lands, but these controls are aimed at protecting public health and safety from flooding, not at conservation of wildlife habitat. Even when programs prohibit structures (as in most floodway

areas), they generally allow and may even encourage uses such as agriculture and recreation (e.g., golf courses and ball fields) that disrupt habitat. Structural flood control measures, such as dams, reservoirs, dikes, levees, and channel alterations, which have been a part of many state programs, actually contribute to riparian habitat destruction in some cases.

### **State river conservation programs**

The twenty-eight state river conservation programs vary widely in content, support and effectiveness; some do little more than label rivers while other provide a measure of protection from streamside development and water projects. (Hoffman 1984, Diamant 1984) The regulatory objectives and the strength of riparian habitat protection often vary with the focus of the managing agency (for example, natural resources, fish and game or parks and recreation). While none of the state wild and scenic river programs identify riparian habitat protection directly as one of their goals, riparian communities benefit from objectives to preserve water quality and free-flowing river conditions, protect natural features, scenic beauty, and fish and wildlife species, and enhance recreational opportunities in rivers.

Within this general framework, river conservation programs utilize a wide range of implementation tools. One of the strongest measures is the consistency provision (enacted in 13 states), which assures that the actions of other state agencies reflect the values for which the river was designated. Most programs include specific requirements that benefit riparian communities, such as maintaining buffer strips against logging, prohibiting mining, and establishing setbacks. These land use controls vary widely in their strictness and enforcement. While some states encourage (and fund) local governments to take over the planning and management of river corridors, most states will still intervene when local actions fall short of state standards.

As federal initiatives in river protection have faded, state and local efforts have experimented with protection strategies. Only a few states have the monetary resources or separate budgets for acquisition of riverside lands (for example, Florida's \$32 million per year Save Our Rivers acquisition program, funded by a real estate transaction tax). Most states have also found that landowner resistance makes purchase of scenic easements costly and often unsuccessful. On the other hand, many managers report that donated easements have worked well since the landowner usually believes in the concept of river preservation. Statewide comprehensive plans (Maine), state standard-setting for local regulation (Minnesota), and tax incentive programs (Oregon) also have been used to implement more traditional approaches.

### **Problems With Programs to Protect Riparian Lands**

State programs to protect wetlands and conserve rivers have proven difficult to implement,

even where strong laws exist. While growing public recognition of the importance of wetlands has enabled some states to enact powerful protection schemes, even these have not been problem-free. A recent report by the U.S. Office of Technology Assessment noted that state implementation of wetland laws has been hampered by lack of funding, minimal monitoring and enforcement, and inadequate legislative support. (Office of Technology Assessment 1984) Habitat conservation through wetland measures has been especially thwarted by lack of specific objectives, agency fragmentation, and insufficient technical information and expertise. Problems in mapping and identification of freshwater wetlands have been created by differences in vegetation types, water levels, and the demands on wetlands for flood storage and habitat, in addition to the relatively small size of many wetlands.

Many of the state river conservation programs now in existence have not proved overly successful, either in the number of rivers designated or in the enforcement of management objectives. The reasons for this are varied, but include: the lack of adequate support or concern for river conservation in the state; state laws which are vague and erect a number of stumbling blocks prior to river designation; landowner resentment of state intervention; the lack of understanding on the part of landowners as to the benefits of the program or of different protection methods; and the lack of a coordinated effort between state and local agencies, private non-profits and citizens groups.

### **STRENGTHENING THE PIECES OF RIPARIAN HABITAT PROTECTION**

For the most part, state instream flow and riparian land conservation measures are inadequate to protect riparian habitat. As noted earlier, instream flow schemes fail to consider the needs of riparian ecosystems. The inadequacy of the several state measures to protect riparian lands--by wetland, floodplain, and river conservation programs--have also made riparian communities vulnerable. Even where strong programs exist, shortcomings such as lack of funding and inadequate data and enforcement often preclude their effective implementation. Aside from creating strong laws where none now exist, states can take several steps to remedy these shortcomings.

### **Better Information**

Virtually every state program suffers from inadequate data about riparian ecosystems. The flow and land needs of flora and fauna, the precise areas they occupy, and the potential effects of proposed activities may not be known, much less considered, when decisions are made, for example, to grant instream flow rights or to permit development in a floodplain. More complete data are needed not only to identify critical resources but also to monitor the effects of human activities on riparian habitat and to enforce regulations. Some valuable information has been developed by recent federal initiatives, such as the National Wetlands

Inventory, and states should seek these data where applicable to their own programs. (Tiner 1984)

### Requirements for Consultation and Coordination

Beyond the collection of data on riparian ecosystems, states need to assure such data are fully considered in decision-making processes. These processes will vary among states, although most have the programmatic means to ensure such consideration. Some state environmental policy acts (for example, in California and Michigan) could be used to require the generation and consideration of data on the impacts of proposed activities on water resources and sensitive lands. Requirements for consolidated or joint permits are another way to orient information-gathering towards riparian ecosystems, and could also stimulate more direct cooperation between the branches of an agency that are responsible for flow and riparian land protection.

Two additional measures take the coordination requirement a step further and warrant particular consideration. One is to designate certain critical riparian areas and require that state agency actions and decisions in such areas be consistent, to the fullest extent practicable, with riparian habitat protection. Another is to attach mitigation and habitat restoration requirements to permits or rights granted for activities that will disrupt valuable riparian lands.

However, if such measures are not crafted carefully, they could lead to more interagency disputes and less protection. Moreover, as the competition for water supply to serve both instream and off-stream uses intensifies across the country, conflicts under federal and state statutes are likely to increase as well. The federal Endangered Species Act is an important model for providing agencies incentives to work out mutually acceptable solutions. It gives the U.S. Fish and Wildlife Service a strong say over federal activities that affect endangered species habitat, but it also sets up a negotiation process that prompts agencies to search for consensus on ways to reduce or avoid adverse impacts. In turn, when disputes over federal programs reach an impasse, the availability of state programs to safeguard riparian habitat can offer a new means for resolving such disputes short of litigation or legislative exemptions.

### Public-Private Partnerships

Notwithstanding the improvements that should be made in the implementation of and coordination among state programs, the scope and amount of protection that they alone can offer to riparian habitat will likely be insufficient. At the same time, the contribution of private, nonprofit groups to riparian habitat preservation has been growing. These groups--which include not only the well-known Nature Conservancy but also many regional and local land trusts across the nation--generally can acquire and retain riparian resources until a public agency is ready to acquire them. Under appropriate

conditions, many land trusts are capable of permanently owning and managing the lands themselves.

Closer relationships with private land trusts should be pursued, not as a substitute for adequate state programs, but because agency and land trust capabilities are complementary. (Metzger 1983) State technical expertise in flow quantification and habitat assessment and long experience in management are for the most part not duplicable by the private sector. Land trusts, on the other hand, often can act to protect threatened land (and, in some states, water) resources more quickly and at lower cost than can most government agencies. Perhaps most important, as land trusts' local constituencies gain experience in protecting riparian habitat, they build grass-roots support for vigorous state programs.

Thus, at a time of tight government budgets, wildlife agencies should work to improve the authority and capability of nonprofit land trusts to safeguard riparian resources. In the long run, strong private sector efforts will be needed to protect riparian resources and to help establish a firmer political base for building cost-effective state programs.

### LITERATURE CITED

- Diamant, Rolf, J. Glenn Eugster, and Christopher J. Duerksen. 1984. A citizen's guide to river conservation. 113 p. The Conservation Foundation, Washington, D.C.
- Harwood, John A. 1981. A legislative proposal protecting riparian vegetation, an endangered habitat: An unconstitutional taking? *Arizona Law Review* 23:341.
- Hoffman, Robert C., and Keith Fletcher. 1984. *America's rivers: An assessment of state river conservation programs*. 233 p. River Conservation Fund, Washington, D.C.
- Huffman, James L. 1980. The allocation of water to instream flows. Final Report, U.S. Department of the Interior OWRT Grant 14-34-0001-8403 (Lewis and Clark Law School, July 1980).
- Ketwig, Ken. 1985. Californians approve funds to preserve rare wetlands. *Audubon Action* 3(1):6.
- Kimsey, Robert A. Water allocation in Utah - Protection of Instream Uses. *Utah Law Review* 1975:697-698.
- Kusler, Jon. 1980. Regulating sensitive lands. Ballinger Pub. Co., Cambridge, Mass., p. 26.
- Kusler, Jon, and Richard Hamann. 1984. Wetland workshop summary: Innovative approaches, unsolved problems, and future directions. *National Wetlands Newsletter*, published by Environmental Law Institute. Nov./Dec.:7-9.
- Metzger, Philip C. 1983. Public-private partners foster land conservation. *Conservation Foundation Letter*, July. 8p. Washington, D.C.

- Sax, Joseph L. 1981. Liberating the public trust doctrine from its historical shackles. University of California at Davis Law Review 14:188-193.
- Schmidt, William E. 1983. U.S. puts beavers to work restoring creeks. New York Times. August 15, 1983:1.
- Scribner, Tom. 1979. Arizona water law: The problem of instream appropriation for environmental use by private appropriators. Arizona Law Review 21:1095, 1112-1113.
- Sherton, Corrine C. 1981. Preserving instream flows in Oregon's rivers and streams. Environmental Law Review 11:395-396, 417.
- Tarlock, A. Dan. 1978. Appropriation for instream flow maintenance: A progress report on "new" public western water rights. Utah Law Review 1978:211, 225-247.
- Thompson, Rick A. 1982. Statutory recognition of instream flow preservation: A proposed solution for Wyoming. Land and Water Law Review XVII:139, 148.
- Tiner, Ralph W., Jr. 1984. Wetlands of the United States: Current status and recent trends. 59 p. U.S. Government Printing Office, Washington, D.C.
- U.S. Office of Technology Assessment. 1984. Wetlands: Their use and regulation. 208 p. U.S. Congress, Washington, D.C.

# Estimating the Economic Value of Recreation Resources: A Legal and Policy Perspective<sup>1</sup>

Stewart D. Allen<sup>2</sup>

A recent Federal Energy Regulatory Commission hearing on proposed hydroelectric development in Montana shows how decision-makers can perceive recreation economics. This case study examines testimony presented on the estimated value of recreation at the dam site, how these analyses were questioned, and their role in the hearing's unusual outcome.

## INTRODUCTION

In 1978, Northern Lights, Inc., a rural electric cooperative, applied to the Federal Energy Regulatory Commission (FERC) for a license to construct a run-of-the-river hydroelectric dam on the Kootenai River in northwestern Montana. To be located at the crest of Kootenai Falls, the dam would have an average generating capacity of about 59 megawatts and cost about \$225 million.

Following completion of state and federal environmental impact statements, FERC held hearings on the project from August, 1982 until April, 1983. Among the intervenors in the hearings were the Montana Department of Natural Resources and Conservation (DNRC), to present information contained in the State's own EIS, and a coalition of groups opposing issuance of a license.

The hearing, which required 67 days of oral testimony in addition to written testimony already filed, dealt with diverse and complex issues; the 68 volumes of transcripts contained nearly 10,000 pages and 740 exhibits. The Administrative Law Judge presiding over the hearing then reached a decision, summarized in nine findings and conclusions.

<sup>1</sup> Paper presented at the First North American Riparian Conference, Tucson, AZ, April 16-18, 1985.

<sup>2</sup> Stewart D. Allen, formerly staff Recreation Specialist, Montana Department of Natural Resources and Conservation, is now a private consultant in Helena, MT.

This paper discusses Montana's testimony estimating the economic value of recreational losses that would result from the project, how those estimates fared in the hearing, and how they were interpreted by the Judge in his decision.

## THE PROPOSED PROJECT

The proposed 925-foot long, 30-foot tall dam would span the Kootenai River just above Kootenai Falls, located near the town of Libby in northwestern Montana. An intake structure upstream from the dam would funnel water from the reservoir to an underground powerhouse before returning it to the river downstream from the Falls.

The average annual flow of water over the Falls is about 13,000 cubic feet per second (cfs). Water flows fluctuate because of varying releases from Libby Dam, a 400-foot high structure 26 miles upstream that inundates about 90 miles of the Kootenai in the U.S. and Canada.

The Applicant plans to maintain a minimum flow of 750 cfs over the top of the dam (and hence over the Falls) at all times. Irregular concrete structures would be placed in the current between the dam and the Falls, to direct water over portions of the Falls that would normally be dry at this flow, which is less than the recorded minimum.

The Falls do not have a continuous vertical drop such as Yellowstone or Niagara Falls, but consist of an initial plummet of 15 to 30 feet followed by a

series of smaller falls and cascades through a two-mile long canyon.

Access to the Falls area is provided by State Highway 2, which parallels the river for many miles. A dirt road leads to an overlook, but the view is partially obscured and the Falls are several hundred yards away. Rough trails lead down a steep hillside and across a flat area to the crest of the Falls.

Other trails lead downstream along the water's edge above the rocky canyon walls. A swinging footbridge crosses the river one-half mile downstream from the Falls, providing access to the undeveloped Forest Service lands on the other shore.

Most of the 64,000 or so people who visit the area annually come to view the Falls. Trout fishing is popular in the swift-flowing waters and rapids stretching several miles above the Falls, where the fishery is rated as a Blue Ribbon (highest value) trout stream. Other activities include picnicking, hiking, and boating. Few people raft or kayak the canyon below the Falls, which is Class IV and tougher whitewater.

The project is controversial among local residents. A mail survey of Lincoln County residents conducted by DNRC found that slightly more people opposed the dam than favored it, with only 16 percent neutral.

#### STATE TESTIMONY ON RECREATIONAL VALUE

The State gained its information on recreational use of the Falls from three surveys: two onsite recreational use surveys; and a mail survey of county residents. This data, combined with many site visits and secondary research, formed the basis for DNRC's description of the existing environment and impact analysis.

The State's EIS said that opportunities for viewing the falls, currently the most popular recreational activity at the site, would change substantially if the dam were built. The falls would not be inundated, but the amount of water flowing over them would decrease greatly, lowering the Falls' visual appeal and the sounds of crashing water present at higher flows.

Opportunities for fishing the popular stretch of water above the falls would decrease as the run-of-the-river dam slowed water velocity and created more habitat suitable for non-game fish species.

Other recreational activities available in the area, ranging from whitewater boating to picnicking and hiking, would be

altered because the setting would take on a more developed, utilitarian atmosphere detracting from existing, more-natural conditions.

The State believed that recreational opportunities that would be created by the project were already available on the Kootenai River, while opportunities that would be damaged were unique.

Northern Lights' proposed mitigation for impacts to recreation, the State testified, would not be effective. Upgrading the primitive existing facilities and improving access to the falls would not make up for changing aspects of the falls area that visitors value the most.

Proposed visual mitigation--redirecting flow with concrete "rocks," would be ineffective given the small amount of water, the State said. Fewer people would be motivated to walk down to the Falls, and many of the site's amenities would be lost or reduced.

The State also conducted an inventory of waterfalls because of debate over whether Kootenai Falls was the last undeveloped waterfall on a major river in Montana. This was found to be the case and, moreover, the State concluded that Kootenai Falls was the largest remaining undeveloped waterfall on a major river in the entire Pacific Northwest.

This increased the significance of the expected impacts to recreation, because the adverse changes would affect a unique recreational resource.

Having described the existing recreational setting, impacts, and the resulting losses in recreational opportunities, the State attempted to place a dollar value on these losses. We believed that this effort required estimating not only direct use values (those associated with on-site recreational use by current visitors), but indirect values (those not dependent on current site use).

Based on past studies, the State classified indirect values into three categories: option value--individuals' desire to preserve the resource for their own possible future use; bequest value--the desire to preserve the resource so it can be experienced by future generations; and existence value--the benefit of just knowing that the resource exists.

The State estimated values using several different methods, each designed to measure a different type of value. These

were the travel cost approach and two types of contingent valuation methods: willingness-to-pay (with either a utility fee or entrance fee payment vehicle); and willingness-to-sell, or compensation. Some respondents were also asked to complete a willingness-to-drive measure, indicating how far out of their way they would drive visit the Falls.

The travel cost method, which estimated demand functions for the site from observed visit rates corresponding to the travel costs from origins at varying distances from the falls, was used to estimate direct use values associated with the falls area.

For the contingent valuation methods, visitors to the falls were requested to participate in an iterative bidding game. In one variation, respondents were asked how much they would be willing to pay for an entrance fee (or how much could be added to their monthly utility bills) to preserve the falls. In the other, respondents indicated how much they would have to be paid (via a reduction in monthly utility bills) to compensate for development at the falls.

Respondents also were asked to place a value on the Falls if the dam were built. This figure was subtracted from the existing value amount they had bid, to approximate losses in recreational value.

The State believed that compensation was the most appropriate measure of recreational losses accompanying the project, because both direct and indirect values were included. The literature also contains support for using compensation to measure damages to amenity resources (Knetsch 1980) and to measure lost benefits (Dwyer et al. 1976; see also Philip Meyer's paper in this proceedings).

The different methods, as expected, yielded different value estimates. The travel cost approach resulted in an estimated annual value of \$355,600 for direct use of the falls. The willingness-to-pay an entrance fee estimated annual direct use values as \$85,200. The willingness-to-pay on monthly utility bills resulted in an annual value of \$1,060,700; this estimate was assumed to include some indirect values.. Finally, the compensation approach, also assumed to include indirect values, estimated annual recreational value of the falls as \$7,680,000.

The State said that these values were conservative because they assumed minimal increasing use levels at Kootenai Falls and that the value of the falls would not increase over time. In addition, none of

the methods attempted to estimate the indirect values to current non-users of Kootenai Falls, an amount that could greatly increase estimated value (Sutherland 1982). The State had hoped to conduct a broad regional survey of non-users, but budget constraints did not permit it.

Describing the many intricacies of the methods used and the variations in findings is beyond the scope of this paper, but the State used many techniques to control for strategic, hypothetical, and informational biases. For example, starting bids and jump bids were varied systematically, and respondents were given one of four levels of information on the project before asked the economic questions.

Duffield (1984) contains a more complete discussion of the estimation techniques and Allen (1982) provides more detail on the use of surveys in recreation impact analysis.

In summary, the State said that the project would cause irreversible and irretrievable damage to a unique, valuable recreational resource, and that the economic value of these impacts was quantifiable and significant--conservatively estimated at over seven million dollars annually.

In a later brief, the State said the estimate of recreational value lost should be treated as a risk, given professional debate over the best estimate of the amount.

#### NORTHERN LIGHTS' RECREATION TESTIMONY

The project developers testified before FERC that the proposed dam would not have such a dramatic effect on recreation at Kootenai Falls.

Their prediction that the project would not damage recreation opportunities at the Falls, and would improve them in some ways, was grounded in their definition of the setting, which differed from the State's. The company's recreation specialist said the Falls served primarily as a rest stop to travelers passing by and as a social gathering area for local residents. He testified that "Kootenai Falls, while scenic, is not in my opinion a place people will visit to gain a high quality natural experience."

He said that planned improvements in recreational development at the Falls, such as more picnic tables, better trails and access, and opportunities to tour the powerhouse, would attract more visitors. Existing opportunities would not be affected because there would still be



water flowing over the falls. Mitigation, he testified, would include placing concrete structures between the dam and falls, to divert water over the steepest ledges closest to viewers.

Northern Lights questioned the survey methodology and findings of the State's two onsite surveys. Their attorneys also disputed the waterfall inventory, claiming that the geographic boundaries were inadequate, that some undeveloped waterfalls were omitted from the inventory, and that Kootenai Falls was not a unique resource.

The Applicant did not conduct economic analyses of recreational opportunities, but its lawyers questioned the State's testimony on several grounds. They said that the most serious flaw with this testimony was its mischaracterization of Water Resources Council guidelines for economic valuation. The use of compensation, they stated, was not reliable.

Much testimony and cross-examination, in fact, centered on whose interpretation of the Water Resources Council guidelines was correct--even though everyone agreed that they didn't strictly apply because the proposed dam was not a federal project.

The Applicant also said that because compensation survey respondents did not know much about the proposed project, they didn't have an adequate basis for giving dollar bids. The large proportion of first-time visitors from out-of-State knew they would not likely be affected so the entire procedure was too hypothetical.

Moreover, the Applicant said, the large difference between the compensation and willingness-to-pay methods, both of which attempt to value the same resource, showed that estimating dollar values was unreliable.

Northern Lights' ultimate argument, however, was that indirect recreational values could not be described as economic values: "Applicant maintains that it is not possible, in either theory or practice, to convert indirect values into economic values, and any analysis which purports to do so is inherently flawed... The indirect use value of a resource cannot be bought and sold in the market place and therefore cannot have an economic value."

In summary, Northern Lights believed it had designed an environmentally sound, efficient run-of-the-river dam that would minimize effects to the aesthetic and recreational setting, which was not a unique or particularly valuable resource.

The few impacts to recreation, the company said, could be mitigated, and planned recreational development would improve recreation at the Falls. The company said the dollar value claimed by the State to represent recreational losses was therefore unfounded.

#### TESTIMONY OF THE FERC STAFF

At the hearings, FERC provided its own testimony on the value of recreation. Its staff economist used a variation of the Unit Day Value method (an approach the State claimed was "crude at best") to estimate the direct use values of the Falls at \$130,000 annually. The proposed dam, he said, would reduce this value to about \$50,000 annually.

During the intensive cross-examination of witnesses, FERC maintained a low profile, leaving most of the cross-examination to the State, the Applicant, and the groups opposed to the project. These parties were therefore interested in how the FERC staff would view the project in its initial brief.

Published in August, 1983, the brief was highly critical of the project, stating, "Staff strongly believes that the issuance of a license to the Applicant in the instant proceeding is not in the public interest and, accordingly, recommends that the Applicant's request for a license be denied...The record shows that, on balance, the preservation of the Kootenai Falls area far out-weighs the need for the project."

FERC said that the project would have significant and unavoidable impacts on visual and recreational resources, in part because of the greatly reduced flows over the Falls. It did not believe that proposed mitigation would be effective, saying "The net result of Licensee's proposal is the destruction of (one of) the last remaining waterfalls in the Pacific Northwest and its replacement with an outdoor water fountain."

The brief argued that both the level and quality of recreational use at the Falls would decrease, and that planned recreational development, the need for which was not shown, would not offset these losses.

## THE ADMINISTRATIVE LAW JUDGE'S DECISION

After considering the sum of written and verbal testimony, the Judge denied the application for license. His decision was based both on the lack of need for the energy and on the project's impacts--particularly those to recreation and aesthetics at the Falls.

His order specified that, "The conflicting interests instrumental in the denial of the application are the changes in the sensual and recreational values that would be caused to the Kootenai Falls by the proposed project..."

The Judge did not accept Northern Lights' position that the quality of recreation at the Falls would not decrease. Similarly, he accepted the State's view that proposed mitigation would not reduce recreational and visual impacts. He also agreed with the State that the Falls was a unique resource, although he didn't agree entirely with the State's waterfall inventory.

In interpreting the decision, it is important to remember that the Judge's standard was whether or not construction of the project would be in the public interest. A central concern was whether the expected impacts would outweigh the benefits of hydroelectric power, and he decided that the current need for the project had not been demonstrated.

If the need for power had been clearly shown, the Judge may have taken a closer look at the some of testimony (or asked for additional information). An example of this was the Judge's view of the waterfall inventory. The Judge believed that the Falls' indirect values stemmed from their unique nature, but said, "If the need for this potential power were more pressing than it is, it might be important to assess in a detailed manner just how unique the Falls are."

Having denied the license, in part on predicted impacts to recreation, the Judge discussed his impressions of the economic testimony. The Judge first decided that the direct use values were relatively small, and would not in themselves block issuance of a license. The issue then became the level of indirect values.

He said, "(the State) gave credible evidence as to the direct use value of Kootenai Falls, but there is no credible dollar estimate of the indirect values. This does not mean that those values are unimportant. It only means that a judgment has to be made as to what weight

those values are to be given...However, as discussed hereafter, these indirect values are an important aspect of the decision that no license should issue."

The Judge based his interpretation of the testimony on indirect economic values on several of the Applicant's criticisms of the State's estimation methods. He agreed that because the majority of visitors were from out-of-State and were seeing the Falls for the first time, their dollar bids should carry little weight. He felt they were not sufficiently informed about the project and its effects to make accurate judgments about value, and that they were not personally and economically involved enough for their views to be considered.

Perhaps more importantly, the Judge questioned the difference between the compensation and willingness-to-pay value estimates: "Anyone is going to be skeptical of methodologies that purport to measure the same subject and get results sometimes as much as twenty times different...(the) opinion that these surveys should not be given great weight by decision makers is persuasive." The State's argument that it was appropriate for the two methods to obtain different values was not accepted.

In the Judge's Findings and Conclusions, he put it more strongly: "...it is not possible to put a dollar value on the principal indirect costs that would result from construction of the Kootenai Falls project."

## IMPLICATIONS FOR RECREATION ECONOMICS

The Judge's perceptions of indirect recreational values should leave recreation economists with mixed feelings. The good news was that the Judge understood and accepted the concept of indirect values. However, his refusal to accept dollar estimates of those values suggests it may be difficult for them to be accepted implicitly in cost-benefit analyses.

The case has several implications for recreation economists attempting similar analyses in contested case hearings and other situations.

1. Economic analyses may have value even if the actual estimates are subject to professional debate. Reflecting on the case, one of the State's lawyers believed that the primary value of the economic testimony was to structure the Judge's thinking about recreation impacts, giving him a framework to acknowledge indirect

values. Without the actual estimates, the Judge would not have had a range of values to consider.

2. Estimates of recreational value must be firmly grounded in a description of the resource being valued. The State first had to convince the Judge of the recreational importance of the Falls, and then of the project's damaging effects, before he could consider indirect values and dollar estimates.

Analyses that produce dollar estimates without first systematically describing the recreational attributes and uses that are being valued may be rejected. If a survey is conducted, for example, one would be wise not to simply ask visitors the minimum number of questions necessary to derive demand curves, or provide contingent valuation estimates. Supportive data are needed.

In the Kootenai Falls hearings, the fact that a recreation planning, management, and behavior specialist was working in conjunction with an economist greatly aided the State's case. Neither was familiar with the methods and approaches of the other, and the resulting exchange of information necessary probably helped both individuals.

3. Good research does not necessarily make good testimony. The many questionnaire variations designed to test for biases probably confused the Judge, and the Applicant tried to capitalize on this. The use of several different methods to estimate different types of economic values also limited the Judge's acceptance. This is not to say that in retrospect the State would have only used one method (such as compensation) to estimate values, but one should be prepared to deal with the complexities involved.

4. Northern Lights' position that indirect values cannot be quantified is a topic that merits further research. More studies that attempt to actually test the validity and reality of individuals' dollar bids for recreational opportunities would help to persuade others that such procedures are not entirely hypothetical. Of course, as more compensation studies are conducted and applied to similar situations, they may gain acceptance.

A survey of non-users of Kootenai Falls, had it found that regional residents would be willing to pay to have a more expensive energy source developed to preserve the Falls, could have anchored the State's estimates of indirect values. Such studies should be seriously considered, especially because the values involved could be significant.

5. Some of the problems encountered are perhaps inherent in recreation economics testimony. A State lawyer pointed out that if the Judge had accepted the indirect dollar estimates for recreation losses, a case could have been made that the indirect values of the hydroelectric energy should also be considered.

Perhaps people place a value on knowing that an energy source is located closer to their homes, or that the source is cleaner than a coal-fired power plant, or that future generations will be able to depend on renewable energy. Needless to say, this really throws the economic analyses for such projects wide open, creating a potentially uncomfortable situation for decision makers.

Also, a full analysis would ideally consider the indirect values and losses present at alternative energy sites--a monumental task for the typical EIS budget.

## CONCLUSIONS

Hydroelectric projects may yield very large, credible economic value in terms of the energy produced. If recreation (or other resources) would be adversely affected, the value of impacts to direct use may not be sufficient to outweigh the power benefits unless the affected resource is both unique and extremely popular.

The value of indirect benefits may therefore be crucial to future development decisions, and is worthy of attention by lawyers, economists, and recreation professionals alike.

Finally, the tale's not over. Northern Lights appealed the Judge's decision to the full Commission claiming, in part, that the State had failed to convince the Judge that indirect values could be quantified. FERC's decision is due this summer.

## LITERATURE CITED

- Allen, S.D. 1982. Evaluating the impacts of resource development on recreation: A case study. Proceedings of the Intermountain Leisure Symposium, Brigham Young University, November, 1982.
- Duffield, J. 1984. Travel cost and contingent valuation: A comparative analysis. Advances in Applied Micro-Economics 3: 37 - 50.

Dwyer, J.F., Kelly, J.R., and Bowes, M.D. 1976.  
Improved procedures for valuation of the contribution of recreation to national economic development. Research Report 128, University of Illinois, Urbana-Champaign.

Knetsch, J.L. 1980. Disparities between alternative measures of economic values. Proceedings, Applied

Research for Parks and Recreation in the 80s.  
University of Victoria, Canada.

Sutherland, R.J. 1982. Recreation and preservation valuation estimates for Flathead River and Lake system. Kalispell, MT: Flathead River Basin Commission.

# Idaho's Riparian Lands: Problems, Concerns, and Hope<sup>1</sup>

Mike W. Anderson<sup>2</sup>

---

A coalition of professional societies and conservation groups banded together to write and support Idaho Legislation that would help protect, enhance, and manage riparian lands. House Bill 105 proposes volunteer participation by landowners in a riparian conservation program that provides a personal or corporate income tax credit for costs incurred in rehabilitation efforts. The 1985 Idaho Legislature debated this Bill.

---

## A Case Study

Many of Idaho's citizens are wondering: What's a riparian? Well, the R.N. Irving Chapter of SCSA, as well as others, wants everyone in Idaho to know what a riparian is and asked me for technical assistance regarding the condition, problems, and importance of riparian land in Idaho. As a wildlife biologist for the SCS, I knew that riparian lands are extremely valuable habitats for numerous species of wildlife and have a direct influence on the quality of aquatic life.

Riparian by Webster's definition is "relating to or living, or located on the bank of a natural watercourse as a river..." When grasses, shrubs, and trees grow in abundance along a stream on the banks and adjacent land, this is riparian land. This transition zone between water and adjacent uplands is identified by the richest soil and an excess of water. They support lush vegetation areas, thus making them attractive and extremely productive for a variety of uses. Trees, shrubs and grasses attain their best growth here and wildlife and fish species abound because their basic needs for food, cover and water are readily met. Men also have been drawn to this area because of its productivity, level terrain and ease of access. With careful management, the area can provide abundantly for man in perpetuity. Riparian areas are acre for acre, the most important lands for producing renewable resources to be found in Idaho. Yet as important as they are, they add up to less than 1% of Idaho's land area. Riparian areas vary in topography, shape, size and form. Some are broad...while others are very narrow and consist only of linear strips of vegetation between steep canyon walls.

Riparian lands in Idaho that are properly managed can produce many benefits for Idaho. Some of them are subtle but others are more obvious. The grasses and shrubs along stream channels filter out sediment from adjacent uplands before

it enters the streams. The root systems of these plants anchor the soil in place reducing stream-bank erosion, especially during high water periods. This vegetation also reduces the velocity of the water along streams allowing more to soak into the ground. This process raises the water table, reduces hazardous flooding and prolongs streamflow. Properly managed riparian systems have adequate vegetation that provides shading, which reduces summer temperatures, discourages algae growth, and insulates the area to reduce heavy ice buildup in winter. Abundant forage for properly managed grazing systems is another characteristic of riparian lands...along with valuable food, water and cover for fish and wildlife. But these benefits are not currently being realized to their fullest. Recent estimates indicate that less than 30% of Idaho's privately owned riparian lands are properly managed to provide these benefits.

The Soil Conservation Service estimates that over 2,500 miles of streambank in the Snake River Basin are moderately to severely eroded. This river basin represents 87% of Idaho's land area. This streambank erosion accounts for a deposit of over 390,000 tons of sediment into the Snake River drainage each year. Riparian lands in Idaho have been severely impacted by man's activities in the last 100 years, primarily due to the removal of the streamside vegetation. You see, along with the benefits already mentioned, riparian lands are highly desirable locations for home construction. Road corridors. Livestock watering and grazing. Crop production. Mining activities. Forest harvesting and recreation sites..... As you can see, there is a wide variety of conflicting uses on these sensitive lands, that many times prevent us from obtaining the benefits that riparian lands have the potential to provide.

There are many factors that affect riparian management. They include: the perception that the stream has always been this way - in many cases, the riparian vegetation was removed many generations previous, so no one has really seen it change; therefore, they think there really hasn't been a problem. There is resistance by the public to land use restrictions, and there is not direct compensation for landowners to reduce commodity production in these areas. There is also a

<sup>1</sup> Paper presented at the First North American Riparian Conference, Riparian Ecosystems and Their Management: Reconciling Conflicting Uses, April 16-18, 1985, Tucson, Arizona.

<sup>2</sup> Wildlife Biologist, Soil Conservation Service, Boise, Idaho.

lack of incentives to encourage restoration or rehabilitation of the riparian area and streamside vegetation.

Idaho's landowners and managers need to realize how sensitive these lands are to abuse, but also how quickly some respond to management techniques or how easy these are to rejuvenate. Several demonstration sites in Idaho and neighboring states have shown how proper management can make considerable improvements in riparian lands. One effort took place on Fifteen Mile Creek in eastern Oregon. This stream was severely flooded in 1974. After mechanical repairs were completed in the stream channel....willows were planted along the banks and grazing restricted. By 1981, the banks of the stream were totally revegetated and shading the stream. Now that I have defined riparian lands and described their importance, the problems, and an example of rehabilitation, let's see how the R.N. Irving Chapter of SCSA got involved with their protection.

In 1982, the Chapter's Fish and Wildlife Resources Division put together a position statement on "Riparian Lands Protection and Rehabilitation." The statement described the problems and suggested tax incentive legislation as a possible solution. SCSA distributed the position statement to many agencies and professional societies -- and got surprisingly positive feedback and high interest. Members of the Idaho Chapter of the American Fisheries Society and the Wildlife Society quickly joined forces with SCSA as a coalition to work for Idaho legislation to protect riparian lands.

The group presented a program to the Idaho Legislature's Joint Resources and Environment Committee in March 1983. The Legislators encouraged them to draft legislation with the suggested tax incentive for their consideration. The group sought other assistance from those whom they felt could help, including the Idaho Association of Soil Conservation Districts, Idaho Conservation League, and Idaho Department of Fish and Game. In November 1983, IASCD unanimously passed a resolution during their annual meeting in support of this legislation. Later in November, the coalition drafted legislation which would grant tax credits to landowners who properly managed their riparian lands. To qualify, the landowner would develop and implement a resource plan with the local SCD's. The Idaho Department of Fish and Game and the Idaho Soil Conservation Commission would develop the implementation program for the local SCDs. The proposed tax incentives included income tax credit for riparian lands rehabilitation and property tax exemption for managed riparian lands.

In January, 1984, the coalition went back to the Legislature with their program and newly drafted legislation. Vard Chatburn, a former SCD supervisor and the Chairman of the House Committee on Resources and Conservation, agreed to sponsor the legislation and introduced the Bill. Unfortunately, when the Bill was formally drafted, it was written with only the property tax exemption. The income tax credit for rehabilitation had been

left out. After lengthy discussion and questioning, the Resources and Conservation Committee decided to have the Bill redrafted to include the income tax credit. They also decided to drop the property tax exemption because of opposition from the County Assessors and Realtors. The redrafted riparian legislation was finally ready for re-introduction in March. But the deadline was past for all committees to introduce it. The legislation was dead for the 1984 session.

1985 brought renewed hope and excitement that Riparian Lands Protection legislation would be successful in this year's 60-day legislative session. The legislation was introduced in the House Resources and Conservation Committee in early January and withstood an effort to send it to the Tax and Revenue Committee. The Riparian Legislation (House Bill 105) with a State Income Tax Credit for riparian rehabilitation came out of Committee with a "Do Pass" recommendation by a slim margin of 2 votes. Before House Bill 105 reached the floor of the House of Representatives, the Governor spoke out against it. He stated that he was for conservation and rehabilitation of riparian lands, but he could not be for any new tax credits regardless of how small the total estimated economic impacts were. When House Bill 105 came up for discussion on the floor of the House, a motion was made to send the Bill to the Revenue and Taxation Committee for further consideration. Without the Governor's support, House Bill 105 lost this challenge by a slim margin of 2 votes. House Bill 105 died in the Revenue and Taxation Committee as the Committee voted by another slim margin not to allow the Bill to go back out to the floor for further debate.

Naturally we are very disappointed that the riparian legislation did not become law in 1985. We also realize that legislation like this takes time to "grow" on the Legislators. We have learned a lot about the workings of State Government and offer the following suggestions for anyone taking on the challenge of working for Riparian Improvement Legislation:

1. Know how your State Government and Legislature work: schedules, deadlines for introduction of legislation, length of legislative sessions, etc.
2. Learn the process a bill takes to become law.
3. Seek the Governor's support for your legislation, ask for his advice and suggestions.
4. Multi-group efforts (coalitions) carry more weight with legislators than individuals.
5. Find, cultivate, and educate willing members of the Legislature so that they will speak favorably for your legislation.
6. We found that most Legislators get their feedback on potential legislation from lobbyists and the news media. Get all the press coverage you can.
7. Seek the advice of a good lobbyist, hire one if you can; they are worth it!

# Streamside Management Units in the Pacific Northwest<sup>1</sup>

Gerald W. Swank<sup>2</sup>

---

ABSTRACT.-- Since 1970 the National Forests in Oregon and Washington have been operating under a Regionally developed streamside management unit (SMU) concept which is essentially a stream classification system based on use made of the water with specific water quality objectives established for each of the four classes of streams.

Inherent in the concept is the underlying premise that the land immediately adjacent to streams is key to protecting water quality but that this land can be managed to protect the riparian values and in most cases still achieve a reasonable return of other resource values.

---

## INTRODUCTION

The riparian related resources in the Pacific Northwest are extremely important. On the 23 million acres of land for the 19 National Forests, there are about 22,000 miles of fish bearing streams and over 200,000 surface acres of lakes and reservoirs, and an unknown additional acreage of wetlands and floodplains. The riparian areas support habitat for a countless number of anadromous and resident fish, and wildlife.

Riparian areas also provide various recreation uses. Last year there were over 32,000,000 recreation visitors days (RVD's) of which at least 3,000,000 were related to use directly in the streams and lakes.

Riparian areas provided part of the forage for almost 255,000 cows and sheep.

Riparian areas are also the most productive sites for growing timber. Almost 5 billion board feet of timber valued at over \$460,000,000 was sold last year. Some of this timber was in or immediately adjacent to riparian areas.

Of the 75 million acre feet of water that flows from National Forest land in the Pacific Northwest some is used by over 200 municipalities for about 3 million people. Present irrigation withdrawals average almost 50 million acre feet annually much of which is derived from Forest runoff.

In short, riparian areas are used for a variety of purposes and are an extremely important social, economic, and environmental part of the Regional and National Forest land base.

However, many of these uses compete with each other. Therefore, it is important that riparian

areas be identified, carefully managed, and monitored.

## DEVELOPMENT OF THE STREAMSIDE MANAGEMENT UNIT (SMU)

In an effort to address this important riparian resource and prompted by executive and legislative action a Pacific Northwest Region Forest Service team in 1970 started developing a policy referred to as "Streamside Management Units (SMU)." This team included representatives from Timber Management, Engineering, Range, Fish and Wildlife, Watershed, and Recreation.

In developing the policy, the team went to the field several times to look at a variety of specific site conditions. The proposed concept was then sent to selected specialists in research, Universities, State agencies, and administrators for technical review. Comments were incorporated into a revised proposal which was formally sent for review to all Forests plus over 30 out-service people and agencies. In 1971 the final SMU policy was finally adopted as policy of the Pacific Northwest Region and a series of field training sessions started. Through the first several years of the policy, about a thousand people were trained in it's on-the-ground application.

## THE POLICY

Streamside Management Units are defined as "the stream and an adjacent area of varying width where practices that might affect water quality, fish and other aquatic resources are modified, as necessary to meet water quality goals for each class of stream."

The width of this area will vary with the management goals for each class of stream, characteristics of the stream and surrounding terrain, and type and extent of the planned activity. SMU will be managed for water quality for the benefit uses, and to comply with the intent of the Clean Water Act.

---

<sup>1</sup>Paper presented at the Riparian Ecosystems and Their Management, Reconciling Conflicting Uses, Tucson, Arizona, April 16-18, 1985.

<sup>2</sup>Gerald W. Swank, Water Group Leader, USDA Forest Service, Portland, Oregon.

Where floodplains, wetlands, riparian type areas, recreation areas or other uses associated with streams exist or are potentially important, the boundaries of SMU's may overlap. If management constraints are in conflict, the most restrictive practices will apply.

Basically, the SMU concept is a stream classification system where four classes of streams are established based on use of the water. Water quality objectives are prescribed for each class. Management practices are designed to meet the objectives of each stream class based on the characteristics or sensitivity of the site in question.

The present and foreseeable uses made of the water, and the potential effects of on-site changes on downstream uses, are the criteria for defining four stream classes. For example, a logjam may prevent fish from using a section of good spawning gravel but if the obstruction were removed, the potential use of stream may be very important.

The importance of use is relative to the general area. Consequently, size of the stream is not necessarily a criterion for classification. Whole streams or parts of streams can be classified. One stream may be sectionalized into several classes.

Class I is defined as perennial or intermittent streams, or segments thereof, that have one or more of the following characteristics:

1. Direct source of water for domestic use.
2. Used by large numbers of fish for spawning, rearing or migration.
3. Flow enough water to be a major contributor to the quantity of water in a Class I stream.

Class II is defined as perennial or intermittent streams that have one or both of the following characteristics:

1. Used by moderate, though significant numbers of fish for spawning, rearing or migration.
2. Flow enough water to be a moderate or not clearly identifiable contributor to the quantity of water in a Class I stream, or be a major contributor to a Class II stream.

Class III is defined as all other perennial streams or segments thereof not meeting higher class criteria.

Class IV is defined as all other intermittent streams or segments thereof not meeting higher class criteria.

Quantitative management goals, the very heart of the policy, are established for each class of stream. These quantitative goals relate to the

water quality standards developed under the Clean Water Act.

For example, Oregon's General Water Quality Standards restrict water temperature increases to 2° F. If the water temperature is already 64° F., no increase is allowed. There are also limiting criteria for turbidity changes and other water quality characteristics. Standards may vary by basin within the state.

Where better information is available for the particular stream in question goals may be modified if formally documented and reviewed.

SMU management goals recognize that some water quality changes may inevitably occur for certain classes of streams in order to obtain the best overall yield and mix of the many land and water resources. Resource planning is aimed at minimizing such changes, in accordance with environmental protection responsibilities.

More specifically, the SMU goals for each class of streams are as follows:

Class I. The use of the water and downstream influence of this class of stream justify the highest level of protection and enhancement. Management activities should not degrade water quality, fish or aquatic resources below the existing or natural level except for temporary changes resulting from:

1. Activities designed to improve the stream, e.g., restoration and habitat improvement.
2. Necessary transportation system crossings, e.g., bridges, culverts or
3. Structures associated with putting the water to beneficial uses, e.g., irrigation diversion, domestic supply intakes.

Temporary changes are those which are transitory in nature; i.e., the effect ceases and water quality returns to its previous level when the permitted activity ceases. Temporary changes do not include increased water temperature, which takes a minimum of several years for shade reestablishment, or turbidity from long-term disturbances such as roads or large denuded areas that act as a recurring source of sediment for a period of time until stabilization is achieved.

Class II. The use of the water and downstream influence of these streams justify a high level of protection and enhancement. Management activities should not deteriorate water quality below established water quality goals except for temporary changes resulting from essential short-term activities.

Class III and IV. The minor on-site use and downstream influence justifies a normal level of protection. Management activities should not deteriorate water quality below existing established water quality goals for downstream Class I and II streams.



Water quality changes in Class III and IV streams may involve some temperature and turbidity increases, provided these do not cause Class I or II waters to fall below established goals. Temperature increases in Class IV streams are normally not a concern as such streams are dry during the critical summer temperature period.

Although Class III and IV streams may individually be small and seem insignificant, they might make up the bulk of the stream mileage within a watershed. Therefore, their cumulative effect can be significant within a particular area and must be considered in overall planning efforts.

Management practices should be designed to meet the objectives for each class of stream based on the characteristics or sensitivity of the site in question. These practices for Class III and IV streams may, in some instances, be more restrictive than for Class I or II streams. For example, a small Class III stream in a V-type canyon of unstable, steep slopes, may require more restrictive practices to achieve on and off-site water quality goals than a Class I stream in a flat, stable valley bottom.

#### HOW IS IT WORKING?

Since the policy was formally adopted twelve years ago, over 112,000 miles of stream have been classified as follows:

Class I - 8,500 miles (8%), Class II - 10,300 miles (9%), Class III - 31,300 miles (28%), and Class IV - 62,300 miles (55%).

The original intent was to deal primarily with water quality and fisheries concerns in streams. The SMU policy is only one part of good land management to protect water quality and fish, as it is aimed primarily at land practices in and immediately adjacent to the stream. Activities far removed from streams can also influence the water streams, significant progress can be made in some of our land management problems. You might say the policy is trying to address the "unpardonable sins."

The SMU policy does not imply arbitrary abstention from all activities near streams. It stresses the need for applying special care in management and prescribes where this special care might occur and to what extent. This provides the land manager with an operational tool which can be translated to activities on-the-ground.

The land manager is faced with the task of deciding how to meet these goals. Rather than trying to prescribe a lot of "thou shall" and "thou shall not" type of practices, the SMU policy recognizes that there may be several ways to accomplish the management goals. On-site characteristics (e.g., slope, cover, soil, etc.) dictate the practices that best meet these goals.

The States of Oregon and Washington have incorporated similar concepts in their Forests Practice Acts. While there are some differences in the classification systems there is a correlation as shown in Table 1.

Table 1.--STREAM CLASSIFICATION CORRELATION

USFS	WASHINGTON					OREGON		
	1	2	3	4	5	1	2	Unclass.
I	x	x				x		
II			x			x		
III				x			x	
IV				x			x	
Unclassified					x			x

The SMU policy has been applied in the timber sale contracts. Special contract clauses have been developed and may be inserted, where appropriate, as a legal requirement.

The current Forest planning effort underway under the National Forest Management Act formally recognizes SMU's (and other riparian-type areas) and focuses more attention on their importance. Management direction is being prescribed in the planning effort.

Some may debate that the policy has specifically resulted in better "on-the-ground" implementation. However, there is no doubt there has been an increased awareness and understanding of riparian areas. While undisputable evidence may be difficult to document, a better job is being done on-the-ground because of this increased concern. The SMU policy in the Pacific Northwest has contributed significantly to that concern.

#### FUTURE NEEDS

As discussed previously, the SMU policy: (1) addresses primarily water quality and fisheries (2) is intended to address only the area in and immediately adjacent streams and (3) does not describe "how" to meet management goals.

Therefore, general action needed for improvement of the three limitations are to:

1. Develop a coordinated resource policy for all riparian-dependent resources such as wildlife and threatened and endangered plants and animals. Implementation should be through an interdisciplinary approach.

2. Develop more technical "how to" guidelines for the general practitioner. An example, is the water temperature publication developed by the Pacific Northwest Region entitled, "Guides for Protecting Water Quality".

Such guidelines should be developed based on "on-site" sensitivity characteristics. This leads to the third recommendation.

3. Develop means to predict how and over what timeframe different riparian areas will respond to different kinds and intensities of management activities. For example, if grazing is controlled or eliminated on a particular riparian area will this result in more large herbaceous shade such as willows, alders etc. and if so how long will it take?

4. Develop a more formalized or structured follow-up process for monitoring and/or tracking the riparian condition and changes due to natural and man-caused impacts.

In brief conclusion the Streamside Management Unit Policy in the Pacific Northwest Region is one way of addressing selected riparian concerns. With more coordinated, technical, and administrative development the program can be improved.

# The Use of Third-Party Intervenors in Negotiated Settlements: Lessons From the Past Ten Years<sup>1</sup>

Verne C. Huser<sup>2</sup>

---

Abstract--Drawing upon a decade of experience in the use of third-party intervenors to help settle riparian ecosystem management conflicts, this paper will suggest a number of lessons for addressing conflict, for designing forums to enable disputing parties to negotiate and for reaching meaningful, realistic implementable decisions.

---

The first settlement of a riparian ecosystem management dispute reached through negotiation with the assistance of a third-party intervenor (mediator) occurred in 1974 -- just over ten years ago -- in the State of Washington.<sup>3</sup> That agreement, known as the Snohomish Basin Mediated Agreement, withstood the transition from the administration of Governor Dan Evans to that of Dixie Lee Ray to that of John Spellman. It was endorsed by two counties, more than a dozen communities and an Indian tribe, none of whom were at the negotiating table, and it lasted for ten years, falling apart during the past year for a variety of reasons.

My point here is that the Snohomish Basin Mediated Agreement started something, a major new concept that has swept the nation during the past decade, a new forum for dealing with natural resource disputes, an old concept -- mediation -- applied to a new field -- environmental controversy.

I often say that environmental mediation is a concept that has been over-sold and under-utilized. By that I mean that a multitude of sins have been committed in the name of environmental mediation. Ill-defined by some practitioners and badly used by others, environmental mediation is no panacea though it has frequently been sold as a cure-all. At the same time the concept of negotiated settlements of environmental disputes with the assistance of a mediator have been applied in far fewer disputes than it might have been, disputes

in which it might have been useful; it has not been used because of bureaucratic neanderthalism or misunderstanding of the concept or the desire by parties to fight it out rather than seek settlement.

In her book Resolving Environmental Disputes: A Decade of Experience scheduled for publication this spring, Gail Bingham of The Conservation Foundation has researched 162 environmental disputes in which the parties have met "face to face, with the assistance of a mediator, to reach a mutually acceptable resolution of the issues in dispute."<sup>4</sup> Sixteen of them (10%) were water resource issues (water supply, water quality, flood protection, the thermal effect of power plants). Another 29 (17%) were natural resource management/use of public land issues (fisheries resources, mining, timber management, wilderness areas) that in many cases affected riparian ecosystems. In other words, a number of riparian Ecosystems management disputes have been dealt with through mediation, many of them settled to the satisfaction of the primary parties, and a few of them even implemented.

A mediator is someone who helps parties negotiate. The mediator is a process expert who has no power to impose a settlement but who merely works jointly with all parties to help them find a solution to their problem. The mediator does not solve the problem; the parties do. An agreement is reached with the parties themselves reach an accommodation they can all live with -- and that they believe they can sell to their constituents and get implemented, that is economically feasible, technologically possible, environmentally sound and politically saleable.

The first decade of environmental mediation has seen concepts emerge and techniques refined.

---

<sup>4</sup>Bingham, Gail, "Resolving Environmental Disputes: A Decade of Experience, Executive Summary", The Conservation Foundation, 1984.

---

<sup>1</sup>Paper presented at the First North American Riparian Conference, Riparian Ecosystems and Their Management: Reconciling Conflicting Uses, Tucson, Arizona, April 16-18, 1985.

<sup>2</sup>Verne C. Huser is Program Associate, Western Network, Santa Fe, New Mexico.

<sup>3</sup>McCarthy, Jane and Alice Shorett, "Mediation to Resolve Environmental Conflict: The Snohomish Experiment," Journal of Soil and Water Conservation, September-October 1976, Vol. 31, No. 5.

The process of applying mediation methods to natural resource disputes has matured through more and more frequent application. Bingham's study determined that 78% of the mediation efforts led to agreements. What we have learned from that decade of experience is the subject of this paper. Let us look at some case studies.

#### SNOHOMISH BASIN MEDIATED AGREEMENT State of Washington

A team of two mediators -- Gerald W. Cormick and Jane McCarthy -- facilitated the deliberations between a variety of interests -- farmers, developers, environmentalists, outdoor recreationists -- at odds about a proposed dam on the Middle Fork of the Snoqualmie River, a long-term and frequently-heated dispute that essentially centered around flood control and development potential for a river valley. The dispute was settled when the parties agreed to a smaller dam on a different tributary, some flood-plain and land-use planning proposals and the creation of a basin-wide coordinating council.<sup>5</sup>

The dam was never built (though a similar one nearby is currently being considered and is creating a whole new range of opponents). Ultimately the funding for the Basin Coordinating Committee, which functioned for nearly a decade, dried up. However, many of the features of the mediated agreement were in place and practice, and the parties to the original agreement remain supportive of the concept and the process.

Lessons Learned? This was the very first attempt to apply the principles of mediation to a natural resource dispute. The pattern established in this effort became the modus operandi in the field: explore the dispute to determine if it is appropriate for negotiation, which parties need to be involved, what issues need to be addressed, what implementation steps need to be anticipated; design a process that is specific to the dispute, find an appropriate aegis to legitimize the concerns and give credibility to the process, develop meaningful deadlines so the parties will make decisions; deal with a whole range of sensitive personal and political issues, create some kind of ongoing relationship among the parties to address implementation problems as they inevitably emerge.

Each new mediation effort tested these principles and added to them.

#### LAKE WINNIPEG REGULATION AND CHURCHILL RIVER DIVERSON PROJECT Manitoba, Canada<sup>6</sup>

A major hydroelectric project in northern Manitoba developed during the 1970's disrupted the

<sup>5</sup>McCarthy, op. cit.

<sup>6</sup>Agreement between the Government of Manitoba and Canada, the Manitoba Hydro Electric Board and the Northern Flood Committee, dated December 16, 1977.

lifestyles of five bands of Native Peoples who depended on the waterways for transportation, hunting and fishing and traditional values. The Canadian federal government provided a mediator who won the trust of the tribes and over a two-year period helped the parties -- five bands of Indians, Manitoba Hydro (a Crown Corporation), the Manitoba provincial government and the Canadian federal government -- reach an agreement (1977) that involved land exchanges, land grants, navigation regulations and a number of other issues dear to the heart and soul -- and livelihood -- of the disrupted people.

Lessons Learned? One of the big questions this mediation effort raised is the independence of the mediator, since he was paid by the federal government, one of the parties. However, the federal government was essentially picking up the tab for much of the settlement, the mediator appointed by the government was trusted by all the parties, and the federal government served as aegis for the entire process that seemed to be acceptable to all parties.

#### PATUXENT RIVER AGREEMENT State of Maryland

A decade-long dispute over how to manage the water quality of Maryland's Patuxent River was settled in 1981 with the help of environmental mediators.<sup>7</sup> The parties were brought to the table by legal action initiated by a coalition of scientists, watermen, and county officials who challenged upstream dischargers. A group of 43 river users, policymakers, scientists and concerned citizens reached agreement on protective measures, flood control and minimum flow guarantees. By some standards the mediators did everything wrong -- too many people, too little preliminary work with the people, too short a time frame, too many complex issues -- but it worked.

Lessons Learned? Perhaps the ground rules for the effort would be instructive:

- Decision will be made by consensus
- No statements made to be used in future judicial or administrative proceedings
- Personal attacks or prejudicial statements will not be condoned
- Conclusions and recommendations will be based on information currently available
- Proceedings will not be electrically recorded
- No contact with the press during negotiations

As in serious labor-management negotiations or international negotiations such as the continuing arms negotiation in Geneva, the Press is not part of the deliberations. The deliberations are not recorded nor can anything said at the negotiating table be held against the parties in another forum. Decisions are normally made by consensus: this is not a hard and fast rule in all mediation, but it

<sup>7</sup>Schneider, Peter and Andy Sack, "Patuxent River Clean-Up Agreement", The Environmental Forum, May 1983.

is frequently insisted upon as the parties design the process that will work best for them in their particular situation. Further, the deliberations are based on factual information available. Philosophical and emotional issues have little place at the negotiating table. You don't negotiate your values.

#### CREST AGREEMENT State of Oregon

A major dispute in the Columbia River estuary was settled in 1981 through the use of mediation.<sup>8</sup> In a bi-state planning process that spanned seven years, a conflict-resolution process designed by the parties with the advice of environmental mediation professionals was used to settle 23 of 28 site-specific disputes. The final five dispute areas, all on the Oregon side of the estuary where a strict land-use planning policy was in effect, were mediated in an open process that involved four federal agencies, four state agencies and four local jurisdictions.

This one was mediated in the press: a reporter from the local daily newspaper attended all negotiating sessions, and because of Oregon's open meeting law was even able to gain access to caucuses. An agreement was reached that became part of local comprehensive plans approved by Oregon's Department of Land Conservation and Development. The Port of Astoria has been using the Agreement as a marketing tool. The Corps of Engineers has been using it as a "guideline" for issuing permits. Environmentalists not at the table feel their concerns were represented by the resource agencies at the table and seem satisfied with the results.

Lessons Learned? If all the parties with an interest in the outcome are somehow represented in the process -- directly or indirectly -- it has a better chance of implementation. If the participants understand the process, in fact help design it themselves, and if that process is designed specifically for the dispute at hand, it is more likely to result in an agreement.

#### WASHINGTON MOUNTAIN BROOK AGREEMENT State of Massachusetts<sup>9</sup>

A dam project in western Massachusetts involving a 19-year evolution from flood control and soil conservation justification to providing municipal water supply led to legal challenges. The protection of a surface water supply system and the taking of state park and forest lands became issues as did the possible contamination of ground water aquifers by pollution occurring along the Housatonic River.

<sup>8</sup>Gusman, Sam and Verne Huser, "Mediation in the Estuary", Coastal Zone Management Journal, Vol. 11, No. 4, pp. 273-295.

<sup>9</sup>Interview with Ty Tice of The Mediation Institute, Seattle, Washington.

With the assistance of an environmental dispute professional, whom one of the parties resisted calling a mediator, the parties reach an agreement, and signed a motion for order of dismissal of the legal action, which was accepted by the federal judge in charge of the case. Incorporated in the order of final judgement is an affidavit from the Massachusetts Department of Environmental Management which states that other state forest and park land resources are protected from depletion by future municipal water supply projects since mitigating land and/or money compensation will be sought in each instance.

Lessons Learned? An independent third-party dispute-resolution professional by any other name would smell as sweet. It matters not that the person who helps parties negotiate be called a mediator. Facilitator will serve as well. It doesn't matter what you call it if it works!

#### OTHER NEW ENGLAND RIPARIAN DISPUTES<sup>10</sup>

A trio of disputes in New England over riparian habitat management issues were settled through mediation. The Upper Androscoggin River in New Hampshire was impacted by the Pontook Project, but agreements were reached on minimal flows for whitewater recreation and fishery enhancement. A small hydro project at the outlet of Swan Lake that affects reservoir levels and flows in the Goose River near Belfast, Maine, was opposed by lake-side residents until an accommodation was reached through mediation. Aesthetic considerations at a waterfall that would be impacted by a hydro project on Otter Creek near Middlebury, Vermont, were addressed through mediation.

Lessons Learned? No matter how small or local the dispute, mediation can serve to settle the dispute if the parties are willing and there is enough flexibility on the part of the powers that be.

#### PLATTE RIVER DISPUTE State of Nebraska<sup>11</sup>

In a long-standing dispute over competing plans for allocating water for the Platte River in Nebraska, a mediator helped The National Wildlife Federation, several state natural resource districts, and other interested parties including the Whooping Crane Heritage Trust develop a sensitive skeletal framework for settlement. Four days of negotiation in late November (1983) initiated a series of constructive talks, the first in years of legal battles and administrative appeals.

In March 1984 the parties reached an agreement in principle providing for a moratorium on litigation and hearings for several years to allow

<sup>10</sup>Interview with David O'Conner of the New England Environmental Mediation Center, Boston, MA.

<sup>11</sup>Interview with Ed Krinsky, Director, Regional Office, The Mediation Institute, Madison, Wisconsin.

for feasibility studies, data gathering, and consensus building and to set priorities for ways to allocate water rights should the date prove it to be feasible.

However, the Nebraska Water Resources Department decided that certain issues had to be resolved through the courts, and the agreement was not implemented.

Lessons Learned? If any of the parties to a dispute want to set legal precedents, it is probably inappropriate for mediation/negotiation. Perhaps another subtle lesson, mediation is not a substitute for politics.

#### ROGUE RIVER AGREEMENT State of Oregon

The "wild" segment of the Wild and Scenic Rogue River in southwestern Oregon is managed jointly by the U. S. Forest Service (FS) and the Bureau of Land Management (BLM). A management plan developed a decade ago which limited use to 120 person launches per day had worked well during the permit season (Memorial Day weekend through Labor Day weekend), the heavy-use period. However, as use pressures increased, especially by private boaters, extremely high use was occurring after the control season, that is, after Labor Day: several hundred boaters were launching each weekend in September and early October, the heart of the traditional fishing season.

The post-permit-season use was out of line with management principles and guidelines. No one wanted more regulations, but something had to be done. The agencies jointly pulled together a working group composed of a representative of each agency and three representatives of private use groups and three of commercial use groups (summer scenic outfitters, fall fishing guides and lodge owners). They hired a mediator to facilitate the deliberations of the joint working group.

Agreement was reached on a series of recommendations, but even though the agencies were represented at the negotiating table and agency representatives had an opportunity to check back with their respective agencies between sessions, the agencies have indicated they are not pleased with the working group's recommendations, a fact that seems to substantiate the feelings of the group members that the process was an exercise in futility.<sup>12</sup>

The working group's recommendations were not implemented the fall of 1984. An interim volunteer system will be in effect the fall of 1985. There is the possibility of a series of public hearings on the subject should the agencies decide to make changes in policies or permit seasons, but at present the non-agency members of the working group

seem to be unanimous in their support of their initial recommendations.<sup>13</sup>

Lessons Learned? There needs to be a clear understanding of what will become of the product of such deliberations. All interests must be well represented in the deliberations and all considerations -- political, economic, technical -- need to be addressed if implementable decisions are to be made through mediator-assisted negotiations. Political pressures and budget cuts can disrupt good-faith efforts to settle differences.

#### SUMMARY

I do not intend to provide you with details of all 45 cases of mediated settlement attempts in riparian ecosystem management disputes that Gail Bingham uses in her book. These examples will serve to suggest that mediation, a term I have used generically in this paper to mean independent third-party intervenor-assisted settlements, has come into fairly common usage during the past decade. More than a quarter of the case studies in Bingham's book deal with riparian ecosystem management disputes.

I do not suggest that mediation is a panacea. It certainly is not nor can it ever be a sure cure for every dispute over riparian habitat issues, but used carefully by skilled professionals in appropriate circumstances, it can be effective in helping parties find agreement in some very complex often multi-party disputes.

People seek settlement when there is enough uncertainty for all parties to make it worth the effort to negotiate, when the status quo is intolerable to all parties and existing forums are not working effectively, when a relative balance of power among the parties exists and all parties are willing to seek a workable solution -- but only if there is enough flexibility within the decision-making system to allow for creative solutions.

I do not mean to suggest that mediation should be used in all or even a majority of disputes, but it does enable the parties to control the decision-making process, to make better use of technical experts, to plan more effectively and to reduce uncertainties. It can be useful in keeping future options open and in improving the psychological climate by helping people learn to work together more effectively.

Mediation can help people make better decisions that are implementable. Decisions that are continually challenged through administrative appeals processes or in court or in the legislature are not good decisions. They cost time and money and people's positions and agencies' prestige. The best reason to try mediation is ultimately to improve your bottom line.

<sup>12</sup>Interview with Don Stevens of Grants Pass, Oregon, a member of the working group.

<sup>13</sup>Ibid.

# An Emerging Riparian Policy in Missouri: Opportunities for Protection, Restoration and Management<sup>1</sup>

Joseph P. Bachant<sup>2</sup> and Richard E. Wehnes<sup>3</sup>

---

The lack of Missouri law protecting riparian wetlands has not completely precluded protection. Resource agencies are seeking better use of existing laws and programs to obtain improved wetland protection. Long-term goals are aimed at developing an informed constituency supportive of updated state water and wetland law.

---

## INTRODUCTION

Missouri is a river state with better than 56,000 miles of stream and river channels that drain six broad zoogeographic regions and nineteen terrestrial subregions. The diversity created by this variety of watersheds and river basins has formed four broad aquatic faunal zones which collectively harbor more than 200 species of fish. This wealth of floral and faunal resources was attractive to both the native American and white settler.

Following the period of exploration into the new world west of the Mississippi, hosts of settlers used the state's waterways as avenues of transportation and commerce into the rich floodplains of the Missouri and Mississippi Rivers and their tributaries. Extensive forest clearing following closely by agricultural development typified the early years of statehood. While many of today's citizens are aware of this era of our history, few recall the guiding federal philosophy that spurred the development of these new lands. The "Manifest Destiny" to conquer the wilderness and make it productive was not a random occurrence; it was engendered in the best public interest of the day. The early federal laissez-faire policy in Missouri evolved into the still existing attitude that "no government is the best government."

A natural development of this historic backdrop is the genesis of Missouri state riparian

law. Water was viewed as a common enemy to be subdued or exploited at all costs. As a result, no body of state water law exists today that recognizes a public interest in such social amenities as fish and wildlife, and recreation.

## RESOURCE STATUS AND CONCERN

A developing state dependent on unreliable watercourses for transportation was not concerned with environmental amenities. A state whose river towns were frequently flooded or whose swamps "needed" draining for farming, did not ask about environmental impacts. As a consequence, an era of massive federal navigation and flood control projects was initiated that lasted until the present day. At the same time, a multitude of private efforts bent on channelizing rivers and leveeing bottomlands claimed even more riverine and riparian resources.

The negative impacts of these efforts are only now being gauged. The grossly altered Missouri and Mississippi Rivers have few tributaries in the state that are unaltered and free-flowing (Michaelson, 1977). Channel modification has impacted almost 5,000 miles of these tributaries. As of 1977, 2,227 miles of these tributaries were completely lost to the filling associated with channel straightening.<sup>4</sup> With the loss of channel length came the loss of natural riparian vegetation. All too frequently, this riparian zone became buried by a levee structure. According to Korte and Fredrickson (1977), 97% of the riparian and palustrine wetlands in Missouri's Bootheel have been cleared and drained in this fashion. The losses of other riparian lands have not been calculated, but these losses have been extensive as well.

---

<sup>1</sup>Paper presented at The First North American Riparian Conference (University of Arizona, Tucson, April 16-18, 1985).

<sup>2</sup>Joseph P. Bachant is Environmental Coordinator, Missouri Department of Conservation, Jefferson City, Missouri.

<sup>3</sup>Richard E. Wehnes is Aquatic Environmental Coordinator, Missouri Department of Conservation, Jefferson, City, Missouri.

---

<sup>4</sup>Fajen, O. (n. d.) Data on file Missouri Department of Conservation Fish and Wildlife Research Center, Columbia, Missouri.

For the past 10 to 15 years, increasing numbers of the state's citizens have begun to question the conventional wisdom of water as a common enemy. This can be seen in an emerging set of public values and concepts that is challenging the need for large federal water impoundments, navigation projects, and channelization. To date, this new coalition has been successful in arresting the completion of several water projects and has challenged others. Not only does this developing public mindset increasingly question old solutions, it is also more mindful of its resource heritage and is eager to restore, protect and manage. The focus of concern to date has been largely limited to federal water projects. Private efforts to alter stream channels and wetlands have been largely ignored. Resource agencies are now beginning the task of better informing this public of the negative impact associated with private activities. If this effort succeeds in shifting public opinion, the results will not be known for at least a few more years. There have been some early successes, however. This past winter, four major Missouri based environmental groups passed resolutions seeking tougher riparian protection.

#### EXISTING OPPORTUNITIES

How does a state with poor water law protect riparian areas while a supportive constituency is forming? In Missouri, several resource agencies have resolved to begin improving riparian conditions through utilizing existing authorities, even if these authorities are not perfect. The following review of the available opportunities include both state and federal programs which may or may not be unique to Missouri alone.

#### Federal Clean Water Act

The Federal Clean Water Act as amended in 1977 contains a provision for regulating dredge and fill activities in wetlands adjacent to the nation's waters. This provision, known as Section 404, provides for a public interest review by the affected public and appropriate environmental agencies. Important provisions can lead to denial of a permit for an activity impacting wetlands, fish and wildlife or water quality. Equally valuable are provisions for project modification, mitigation of impacts and restoration of unpermitted activities.

#### Wetland Determination

A serious limitation has been the wetland definition used by the regulatory agencies. One recent legal effort in Louisiana directed the U. S. Army Corps of Engineers and the Environmental Protection Agency to more liberally define bottomland hardwoods as wetlands; however, this decision has not been universally applied (Avoleyes v. Alexander). Implementation of this decision in Missouri is critical since bottomland hardwoods constitute most of the state's wetlands, and Corps' jurisdiction in these riparian areas would bring modification proposals under a permit

program. The regulation of such activities as riparian clearing, channelization and levee construction which deleteriously impact riparian resources depends heavily on applying Avoleyes v. Alexander outside of Louisiana.

#### Nationwide Permits

One of the critical issues of Section 404 as an environmental regulatory effort is how it applies to headwater streams. Ecologists are aware that the cumulative impact to the 38,000+ miles of Missouri headwater streams can greatly influence riverine and riparian conditions in downstream receiving waters. Unfortunately, the Corps' Nationwide Permit for activities in headwaters has not been effective in controlling riparian losses. The Missouri Department of Natural Resources, the statutory agency with regulatory powers over water, soil, air and waste disposal, has denied water quality certification for several of the Corps' Nationwide Permits, including the Headwaters Permit. It is actively trying to establish conditions applicable to Missouri before certifying these Nationwide Permits. By conditioning headwater projects to require a more thorough review of activities involving riparian wetlands, channelization, sand and gravel dredging and water withdrawals, additional riparian control is possible in areas where any proposal was formerly approved with a rubber stamp.

#### Section 404 Advantages

What we can do through the 404 program is modify or condition project proposals, as well as seek restoration or mitigation of unpermitted activities. Restoration of riparian corridors are prime objectives in restoration or mitigation plans and permit conditions, but are not universally received by the five Corps Districts serving Missouri. One action taken by the State of Missouri that has greatly facilitated uniform approaches to controlling activities in riparian and channel areas is the formal adoption of Channel Modification Guidelines by the Missouri Department of Natural Resources. These guidelines, based in part on the guidelines adopted by the Soil Conservation Service and the U. S. Fish and Wildlife Service, are a hierarchical list of modifications. Applicants must demonstrate, often through engineering techniques, that environmentally benign approaches will not work in their situation before water quality certification is granted. Riparian conditions are important parameters in these guidelines and riparian restoration or mitigation is often a condition for permitting any alteration to a natural stream channel.

#### PL-566 Program

A second federal activity of growing importance to riparian concerns is the Small Watershed Program (Public Law 83-566) of the USDA Soil Conservation Service. Recent watershed plans in Missouri have been placing emphasis on applying land treatment practices in the headwaters of



watersheds rather than such structural approaches as large flood retarding impoundments or channelization. Land treatment consists of a number of traditional soil and vegetative conserving practices. A new practice under study for potential application in current watershed plans is the designation of a long-term riparian corridor. This concept would require a three-party agreement involving the local Soil and Water Conservation District, the Soil Conservation Service and the Missouri Department of Conservation. This program, if adopted, would set aside a maintained riparian corridor of 100 feet in width on both streambanks within certain reaches of designated watersheds for a 75 year period. The division of responsibility as presently conceived is as follows:

\*\*Soil and Water Conservation District would obtain land rights through donation or purchase of easements to be held by the project sponsors; enforce easement restrictions; maintain works of improvements.

\*\*Soil Conservation Service would provide all funds for initial stream channel debris removal, if necessary, under environmental guidelines: provide 50% cost sharing for fencing for livestock exclusion; provide 50% for streambank revegetation costs.

\*\*Missouri Department of Conservation would assist the local district in providing up to 50% of land rights costs; provide an operation and maintenance share not to exceed 50% of costs exclusive of overhead costs; assist SCS in providing technical assistance in vegetation management and implementation of environmental guidelines for channel and streambank maintenance; provide habitat planting materials; participate in periodic project inspection.

While final agreement has yet to be accomplished, the work completed to date is significant in that it marks one instance where government agencies and landowners agree on an approach and are willing to demonstrate its effectiveness. If successfully implemented, a long-term effort to reestablish riparian health will mark a national first using this approach.

#### Soil and Water Conservation Districts

One hundred eleven of Missouri's 114 counties each have a local Soil and Water Conservation District. The Missouri Department of Natural Resources, through the Soil and Water Conservation Program, assists in setting up the districts and acts as an administrative body, passing cost share monies through the districts for approved conservation practices. The Soil and Water Conservation Districts will soon receive new monies from a 1/10% sales tax recently approved by voters for accelerated soil erosion protection measures. Riparian and riverine ecosystems will be improved by reduced sediment in water courses

when conservation practices are encouraged in watersheds. Riparian corridors will also be directly benefited by new cost share measures that will encourage designation and protection of riparian areas. Riparian revegetation will be a practice eligible for cost sharing through the Soil and Water Conservation Districts. A second new cost share practice for fencing to exclude livestock will allow designated riparian areas to revegetate and stabilize.

#### Riparian Purchase

Traditional land purchase is a time-honored way of establishing ownership, and hence a "say" in the management of river systems. The public trust doctrine gives resource management agencies an ephemeral power of protection on private lands but damages from, say, a channelization project directly or indirectly affecting public holdings gives an agency a more tangible legal standing, especially in civil proceedings. The Missouri Department of Conservation, since 1976, has had an earmarked 1/8 percent sales tax as well as traditional income sources, which has been used for expanded land acquisition, development, management and educational programs. A direct benefit to riparian preservation is the land acquisition program which has added 188,000 acres in 536 tracts in state ownership within the past 7 1/2 years. Many of these areas have stream frontage which can also now serve as research/demonstration riparian areas. In addition, the Department is examining the potential of obtaining riparian easements. This effort would either be as a direct contract with individual landowners or through a riparian PL-566 Program described earlier, or a combination of both.

#### Interagency Streambank Committee

The recent focus of state and federal programs listed above has created the need for technical guidelines for the stabilization of streambanks and the establishment of riparian corridors. Unfortunately, the lack of agency interest in the past has left us a legacy of no experience in dealing with these problems. Meanwhile, riparian owners are increasingly experiencing streambank problems, calling on inexperienced agencies for advice. A recent survey in one west Missouri watershed showed that over 80% of riparian owners had what they believed to be a stream problem. Sixty-five percent had attempted to correct the problem in the past, and 96% were seeking technical assistance to deal with the problem, either because they had not tried to correct their problem or their solution failed.<sup>5</sup>

This need was addressed by the creation of an interagency committee of state and federal agency representatives who were charged with developing standards and specifications to be used in

---

<sup>5</sup>Turner, W. M. (1984). Missouri Department of Conservation Memorandum to James P. Fry dated December 18, 1984.

implementing programs of streambank and riparian restoration and stabilization. A large number of agencies participated: Soil Conservation Service, Corps of Engineers, University of Missouri, Forest Service, Fish and Wildlife Service, Missouri Department of Conservation and Missouri Department of Natural Resources. Standard techniques successful in other parts of the nation were reviewed and adapted to Missouri streams and soils. Since work on this committee began, several members have been involved in an ever-increasing demand for assistance in streambank erosion control and revegetation from private riparian owners. A new stream management program (potentially funded through the federal Wallop-Breaux fund) is now being considered by the Missouri Department of Conservation which would incorporate the above specifications for riparian and streambank stabilization into riparian demonstration areas and technical assistance to landowners. Adoption of this program is seen as the best means for improving the state's riverine fisheries.

To date, this committee has had a unifying effect in deepening the resolve of the same member agencies to more fully address and enhance riparian conditions. Draft guidelines to the restoration and management of Missouri's streambanks, channels and riparian zones are expected.

#### Education

Conservation education has been a long-term Department of Conservation commitment which may, in part, explain the development of the state's environmental constituency. A wide variety of I & E approaches are pursued: magazine and newspaper articles, speeches, and the like. The Education Section of the Missouri Department of Conservation has developed some riparian education material that are used in school curricula across the state. Children are told to "...be wise, don't channelize," but an educated constituency is needed now because stream losses are ongoing and cumulative. One highly successful effort recently undertaken is known as "A Day on the River." Here, the interested public can spend a day in a river/riparian environment with Department experts learning first-hand about river ecology and the status of the resource. Since the new Wallop-Breaux funds mentioned above earmark up to 10% of the new federal aid monies for aquatic oriented education, an expansion of this effort in Missouri is being considered.

#### POTENTIAL OPPORTUNITIES

This discussion so far has focused on the principal opportunities available or under development within our state. There are several other up and coming incentives that may be worthy of mention--some may have a fair probability of enactment; others are longshots. We list them because political climates change, as well as the demands of constituencies. Several years ago, for instance, we would have told you that a water use

registration requirement would have no change of passage, yet the last General Assembly enacted an amendment requiring reporting of consumptive water use or withdrawal.

#### Critical Area Treatment

A companion program with the USDA Soil Conservation Service is the Critical Area Treatment effort authorized by PL 74-46. Here, federal funds are targeted for those areas in the country that exhibit extraordinary amounts of soil erosion. Since Missouri ranks high in this regard, several such areas have been established in the state. The long-term result will be seen in improved water quality. The impact to riparian environments could be significant if this program follows through on identification and implementation of revegetation practices for streambank erosion control.

#### Water Conservancy Districts

Currently, legislation establishing water conservancy districts is under review as part of a beginning effort to update water-oriented legislation. Water conservancy districts can currently be established for the purposes of flood control, channelization and levee construction. With slight changes, the ability to significantly alter river and riparian areas could be brought under environmental guidelines and the possibility of establishing such a district for the purposes of corridor protection and management could be realized. This would provide local authorities a mechanism for improving stream channel and streambank conditions. The key will be the installation of strict environmental guidelines within the enabling statutes.

#### Forest Cropland Law

Another example of providing better protection for riparian ecosystems is through the Missouri Department of Conservation's Forest Cropland Law. The law, originally passed in 1946 to encourage timber production on marginal lands, provides that landowners with approved Forest Cropland have a portion of their property taxes paid by the Missouri Department of Conservation. While in a practical sense it now applies only to upland forests, an extension to specifically include riparian forests would provide protection in a manner similar to that espoused by the Oregon Riparian Act, i.e. tax relief on dedicated riparian lands. Certain types of management activities could be permitted, such as regulated timber harvest for fuel wood or saw logs provided they did not interfere with the biological functioning of the riparian community. Implementing such a law would require amending the current law to include riparian forests and to designate acceptable practices therein.

#### Conservation Easements

Another opportunity yet to be considered is the use of conservation easements which would promote long-term commitments of riparian areas to

conserving uses. By dedicating riparian corridors through conservation easements to a holding agency, income tax advantages accrue to the owner. This may seem far-fetched, but one group of Missouri landowners had considered dedicating their bottomlands in an attempt to halt a federal impoundment project. While stop-gap in nature in this instance, it does point to an opportunity that could be used in the future.

#### Farm Foreclosures

An opportunity may be at hand with the foreclosure of many agricultural properties by the Farmers Home Administration. Several Missouri Agencies are advocating amending these deeds to provide for conserving use in critical areas, especially those that are severely eroding or have riparian areas, before the deeds are offered for public sale. This opportunity is very remote, but given the right circumstances, may be implemented.

#### CONCLUSION

The State of Missouri has indeed entered a riparian crossroads. The effects of state and federal regulatory efforts on the one hand are slowly pushing and nudging individuals and others bent on modifying riverine/riparian conditions toward a more environmentally acceptable norm. On

the other hand, management assistance and educational efforts are drawing the public toward a better understanding of the issues and imparting more enlightened concepts and solutions as well as a better appreciation of the state's riverine/riparian resources. Since laws are crystallized public opinion, the long-term goal of a new body of state law protecting the public values intrinsic in these resources must start in the public mind. In our view, the studied utilization of existing authorities has initiated a feedback mechanism which will make riparian preservation more obtainable in the future.

#### LITERATURE CITED

- Korte, P.S. and Fredrickson, L.A. 1977. Loss of Missouri's Lowland Hardwood Ecosystem. Transactions of North American Wildlife Conference. 42:31-41
- Michaelson, S.M. 1977. Missouri Stream Resources. Missouri Conservationist 38(3):20-21.

#### ACKNOWLEDGMENTS

We thank James P. Fry, Stanley Michaelson, Earl Pabst and Daniel Witter for critically reviewing the manuscript and for providing constructive criticism.

# Managing Multiple Resources in Western Cascades Forest Riparian Areas: An Example<sup>1</sup>

Jon Vanderheyden<sup>2</sup>

---

Abstract.--The U.S.D.A. Forest Service concepts of multiple use and riparian area dependent resources were incorporated into a district level riparian area management policy. The linkage of riparian areas to the aquatic resource and cumulative watershed processes is integrated into the policy designed to provide consistent direction for on-the-ground management.

---

## INTRODUCTION

In the mid 1970's the U.S. Forest Service received increasing public pressure regarding the management of water resources and the lands which influenced them. In response, a national task force was created to study riparian area management within the Forest Service. The result was a new Washington Office Policy which specifically addressed the management of riparian areas. The new policy identified four key elements which were deemed essential to successful riparian area management. These were:

1. Recognition of the importance and distinctive values of riparian areas in land use planning and project analysis.
2. Preferential consideration for riparian area dependent resources.
3. Management of riparian areas under the principles of multiple use.
4. Delineation of riparian areas prior to implementation.

The concepts of "recognizing distinctive values" and "riparian area dependent resources" were new to the direction contained in the Forest Service Manual.

The Pacific Northwest Region of the Forest Service reissued it's streamside management policy as a regional supplement to the new riparian area policy in September, 1980. The supplement dealt primarily with stream classification and management practices needed to protect water quality and was reissued to bring the regional direction for stream

management into the new riparian area management of the Forest Service manual.

When the new riparian area policy was issued, the Willamette National Forest was operating under an approved comprehensive Land Management Plan<sup>3</sup> which had adopted the Region Six streamside management direction. The new riparian area policy was not specifically addressed in the plan though it clearly identified a change in emphasis for management of riparian area resources. Any changes in existing management which could be implemented within the direction of the Land Use Plan would hasten the eventual implementation of the new policy.

In addition to the new riparian area policy, increasing attention was being directed at the management and analysis of cumulative effects. The influence of watershed processes on surface water resources was a focal point of this increased attention.

The Rigdon Ranger District, located in the Cascade Mountains of western Oregon, initiated a management review of streamside management to determine what opportunities existed for implementing the new riparian area direction and better addressing the cumulative effects concern. Management of streamside areas on the District was emphasizing water quality protection and resident fisheries rather than the broader concept of riparian resources. This inconsistency with the Washington Office policy led to confusion for District staff and planners regarding the resource emphasis to be managed for in riparian areas. Personnel who developed project contracts and completed field layout had difficulty determining the objectives of project plans and this resulted in highly variable results on the ground. The District identified a need to develop a consistent

---

<sup>1</sup>Paper presented at the First North American Riparian Conference, Tucson, Ariz., April 16-18, 1985.

<sup>2</sup>Jon Vanderheyden is a hydrologist, U.S.D.A. Forest Service, Willamette Nat. For., Rigdon and Oakridge Ranger Districts, Oakridge, Oregon.

---

<sup>3</sup>U.S.D.A. Forest Service, Pacific Northwest Region, Final Environmental Statement, Willamette National Forest, U.S.D.A.-FS-R6-FES(Adm.)-75-19.

rationale for riparian area management to minimize the conflicts over resource emphasis. The objective was to provide consistent, high quality management of riparian areas. A riparian area management guide was developed which incorporated the new riparian area direction and a broader watershed perspective of forest management.

#### WESTERN OREGON CASCADE RIPARIAN AREAS

The Rigdon Ranger District encompasses the headwaters of the Middle Fork of the Willamette River. Rainfall in the area averages from 40 to 80 inches per year, with 80 percent of the precipitation falling between October and March (Harr, 1976). Above 4000 feet in elevation, most of the precipitation falls as snow, and a continuous winter snow-pack is maintained. Soils in the area are derived from volcanic rock, and high elevation soils typically have a covering of pumice and ash. Mass erosion processes predominate over surface erosion (Swanson and Fredricksen, 1982) and have significant interactions with stream channel<sup>4</sup> and basin morphology. Vegetation in the area is dominated by the western hemlock (*Tsuga heterophylla* (Raf.) Sarg.) climax type but the principle tree species is the subclimax Douglas-fir (*Pseudotsuga menziesii*, Mirb. Franco.). Biomass accumulations in these forests are among the highest in the world (Franklin and Waring, 1979). True fir species (*Abies*) are a significant part of forest stand types above 4000 feet elevation.

The exceptional tree height and diameter characteristic of these forests results in a riparian area that is significantly affected by the adjacent forest lands. Because of the high precipitation, riparian areas are not vegetatively or geographically distinct from the terrestrial area; however, their character is unique in several respects. In riparian areas of third order (Strahler, 1957) and larger streams the near complete cover of coniferous vegetation is reduced by the presence of deciduous trees. The growth of the hardwood vegetation is made possible by the presence of a shallow water table which provides water during the summer drought period. The lack of summer precipitation also limits the availability of surface water for wildlife during this season. The greater cover of angiosperms found in the riparian area gives rise to greater production of mast and nectar than is found in the upland terrestrial setting. This provides wildlife with a variety of food sources in a concentrated area. The "V" shaped and "U" shaped valley configurations juxtapose big game winter range habitats with riparian areas, where the dense overstory forest creates an energy balance which keeps temperature extremes dampened relative to more open and terrestrial locations (Harris, 1984).

<sup>4</sup>Lyon, J.K. 1981. Influence of landslide, floods, and land use on channel changes of the upper Middle Fork Willamette River, Oregon 1936-1980. Unpublished Master of Science Thesis, Oregon St. U., College of For., Dept. of For. Eng., Corvallis, Oregon.

Stream and river habitats have been depicted as a continua of biological organization from low order, headwater streams to higher order receiving rivers (Cummins, 1975). Small headwater streams are dominated by hillslope erosion processes and coniferous vegetation. Downstream, as the channel widens, more sunlight is input to the stream, thus increasing the amount of hardwood riparian vegetation and the autotrophic production within the stream. Stream invertebrate communities shift in response to this energy change from shredder/collector functional groups to shredder/grazer/collector types (Hawkins and Sedell, 1981).

A significant characteristic of instream habitat is the presence of woody debris derived from the terrestrial forest. The low order headwater streams are typically buried under woody debris with amounts upto 23 tons/100 feet of channel (Froehlich, 1973). Because these streams are almost completely shaded, woody debris is the principle biological energy source for the aquatic foodchain. Downstream, the ratio of forested stream edge to water surface area decreases, as does the loading of woody debris. Large woody debris, such as tree boles and large limbs, interact with the stream to create steps in the channel profile and scour pools where flows are concentrated. The debris also provides cover for aquatic biota. In fourth and fifth order channels whole-tree size debris modifies channel habitat by protecting mid-channel gravel bars and creating protected side channels. Wood biomass production is still high in the riparian area, but loading in the channel is greatly reduced. This is primarily due to the great increase in the stream's ability to flush material downstream. The proportion of the aquatic food base which is derived from solar inputs and by-products of upstream wood processing is increased.

The consequences of these riparian area characteristics on land management and use are substantial. Up to 80 percent of forest dispersed recreation use occurs in the riparian zone (Clark et al, 1984). The thermal cover and diversity of food which attracts wildlife subsequently attracts the hunter and wildlife observer. The availability of soil water during the summer drought period results in the greatest tree growth and the highest per area yield of timber products. Along higher order streams, the broad valley bottoms provide for easy, low cost road construction in a central location which enables the development of an efficient transportation system. In lower order streams, the steep slopes and narrow valleys restrict the transportation system to upslope areas. This results in the riparian area being at the distal portion of the typical forest harvest unit, thus increasing the average yarding costs for the riparian area.

#### DEVELOPING A RIPARIAN AREA MANAGEMENT POLICY

The magnitude and diversity of values in Pacific Northwest riparian areas make them one of the most challenging of all forest management efforts. The great variety of uses available there gives rise to many potential conflicts but also present numerous opportunities. Providing the best mix of use

requires consistent, well balanced direction which is responsive to both public demands and conditions on the ground. To implement such a program, both managers and field personnel must have a thorough understanding of objectives and how the objectives can be implemented. To accomplish this, the Rigdon Ranger District chose to develop a district level riparian area management policy.

The first step in developing this policy was to review the existing Forest Service direction pertinent to the management of watersheds and riparian areas. The first Willamette National Forest, Land Management Plan was completed in 1977 and provided management direction to all Forest District Rangers through 1986. However, the policy review was undertaken to determine the intent of all existing direction relative to riparian areas and as such it extended beyond this guiding document. A new round of Forest land and resource management planning was in progress when the district review was initiated. This process had identified minimum standards and guidelines related to soil, water and riparian areas and these were also incorporated into the review.

A common denominator found throughout the direction was the concept of riparian area dependent resources contained in the Washington Office riparian policy. This concept generated several questions which needed to be addressed in order to develop a management strategy. Among these were:

1. What were the riparian area dependent resources of the district?
2. What characteristics of riparian areas were responsible for their existence?
3. How did the natural and/or altered processes of the watershed interact with the function of the riparian area?

A list of wildlife and fish species was developed which are dependent on, or principal users of riparian areas (Guenther and Kucera, 1978). Water oriented dispersed recreation use was identified as a riparian dependent resource (Clark et al, 1984). A listing of plant species which were indicators of mesic sites was developed to aid in identifying the boundaries of riparian areas. Field conditions which were responsible for maintenance of these resources were identified by the district hydrologist, wildlife biologist and recreation forester.

From this resource data, goals and objectives were established. Because of the variability of riparian areas between various size lakes and streams, it was necessary to categorize the different conditions into groups. The groups selected were; (1) the watershed, (2) fish bearing streams and lakes, (3) perennial non-fish bearing streams and lakes and (4) intermittent streams and channel headwalls. Resource management objectives and goals were broad in nature and addressed watershed and stream processes and/or wildlife habitat conditions. The objectives were then defined and clarified by a set of ground conditions and/or management practices which are desired or need to exist for the objective to be met. This format was an important feature

of the policy. The broad resource objectives provided a conceptual goal for the resource manager while the ground conditions and management practices provide a mental picture for field personnel. A common understanding of the management objectives was thus insured.

A draft of this documentation was put together and reviewed by the district ranger and staff. Comments and changes were incorporated into a final draft which was adopted for implementation as district policy. The policy is to be used until the new Forest wide, land and resource management plan is approved and implemented.

#### UNIQUE ASPECTS OF THE POLICY

A number of unique modifications of the existing direction on riparian area management were incorporated into the district policy. None of these changes conflicted with the existing management direction but were more of an updating based on new direction and research.

#### Definition of the Riparian Ecosystem

The first major point of refinement was the definition of riparian areas. The Forest Service manual defines riparian areas as:

"geographically delineated areas, with distinctive resource values and characteristics, that are comprised of the aquatic and riparian ecosystems, floodplains, and wetlands. They include all areas within a horizontal distance of 100 feet from the edge of perennial streams or other water bodies."<sup>5</sup>

The manual further defines riparian ecosystems as:

"... a transition between the aquatic ecosystem and the adjacent terrestrial ecosystem and is identified by soil characteristics and distinctive vegetation communities that require free and unbound water"<sup>5</sup>

The riparian area definition clearly takes a broad view of "riparian" particularly with the inclusion of floodplains and wetlands. However, the free and unbound water dependent vegetation criteria in the riparian ecosystem definition is based on an edaphic and botanic approach to riparian areas and is much more restrictive.

The definition is also rather myopic relative to ecosystem function. If the riparian area is an identifiable transition zone between the aquatic and terrestrial ecosystems, we must accept that inputs and outputs of this system will enter and exit from both of the adjacent systems.

---

<sup>5</sup>U.S.D.A. Forest Service, Forest Service Manual, Washington D.C., Title 2500, Watershed Management, FSM 2526.05

Because of these discrepancies, a new definition of the riparian ecosystem was adapted in the district policy. The definition is based on the concept of the water influence zone (Meehan et al, 1977) and defines the riparian ecosystem as:

"The transition zone between the terrestrial landscape and water landscape features such as streams, lakes, wetlands and ponds, which has distinctly unique soils and vegetation as influenced by the presence of a high water table and includes the landscape area which directly influences the aquatic, wetland and/or floodplain area."

#### The Watershed Perspective

The tie between riparian areas, and the watershed as a whole, is intricate in steep mountainous terrain (Hynes, 1975). This concept has long been recognized by the Forest Service but has received increasing attention in recent years as interest in the assessment of cumulative effects have increased. The planning of silvicultural activities at the Rigdon Ranger District has been based on subwatershed areas for several years. The Willamette National Forest utilizes a guideline for forest stand hydrologic condition which is based on the hydrology of rain on snow precipitation events (Christner and Harr, 1983). The guidelines below were incorporated into the watershed section of the district policy as a means of assessing the cumulative effects of watershed processes and conditions on the riparian area.

#### Hydrologic Condition

Hydrologic condition is based on an aggregate of stand conditions within a subwatershed (third to fourth order basin; Strahler, 1957). Each combination of stand cover and average tree size correlates with a percent stand recovery. A recovery of 100 percent equates with 70 percent cover of 8 inch diameter trees. A minimum aggregate recovery of 75 percent is the objective within a given fourth order subwatershed.

#### Mass Soil Erosion

Mass soil failure occurrence is limited to twice the rate which has historically occurred during a comparably sized storm event. Headwalls, (wedge-shaped, topographic depressions typically located at the upper end of first order channels) receive special consideration in some situations. Generally, these special headwalls are located on greater than 75% slopes, where historic evidence of soil failure is present. On these areas, 60% of the existing rooting strength is retained and an attempt is made to limit ground surface disturbance to less than 5%.

#### Riparian Habitat and Stream Shade

Consideration for the cumulative effects of harvest on riparian habitat and stream channel

shading are incorporated into the direction. Along fish-bearing streams, stand cover is to be maintained at 80 percent of the original overstory canopy, 80 percent of the original understory canopy, and 60 percent brush cover. The total riparian area not meeting these conditions on a given stream is limited to 10 percent. These criteria allow for some harvest of trees when it is economically desirable and also allows for narrow corridors through the zone needed for the setup of cable log yarding systems.

In addition to stream shading factors, the input of litter and fine organic material to the stream system is of concern, because Pacific Northwest streams are highly dependent on these inputs. To assure the maintenance of detrital inputs and stream shading, 75 percent shade and 60 percent of the cover within 20 vertical feet of the water surface is retained on perennial non-fish bearing streams.

#### First Order Streams

In ephemeral and/or intermittent streams, the principle management considerations are the introduction of sediment and the potential to deteriorate downstream water quality. A decision key was developed for determining which implementing requirements are needed to maintain downstream values. The key is based on: 1) an estimate of annual peak flow size, 2) channel gradient, 3) channel bank condition, 4) sideslope steepness, and 5) proximity to fish bearing streams. In general, the steeper the channel and terrain and the closer the area is to a major stream, the more restrictive the implementing requirements. The principle implementing requirements which are evaluated are: 1) leave vegetation, 2) directional felling of trees during harvest, 3) suspension of trees over the ground during yarding, and 4) the need for removal of logging debris added to the stream.

#### Large Woody Debris

The guidelines for the retention of large woody debris in streams are a major addition to the direction existing prior to adoption of this district policy. Large woody debris size was defined based on stream channel width. In general, a piece qualifies as large woody debris if it is 1.5 times as long as the width of the channel, and it's diameter in inches is equal to the channel width in feet. For channels greater than 100 ft. in width, whole trees which are at least 25 inches in diameter are suggested. The amount of debris in the channel is also determined by the channel width. For example, in perennial non-fish streams, suitable pieces of debris are suggested every two channel widths while in larger fish bearing rivers suitable debris is suggested on an average of every four channel widths.

#### CONCLUSIONS

Pacific Northwest riparian areas have many unique characteristics which result in a high concentration of forest resource values and use.

Identifying the degree of dependence of these values and uses on specific characteristics of the riparian area is a key to determining which resources are to be emphasized during management. In turn, determination of which resources will be emphasized is a key step in minimizing management conflicts which arise when planning and implementing projects. To develop the degree of consensus necessary for an implementable riparian area policy requires close, interdisciplinary team work. Such a policy must follow the intent of law and policy direction, be sensitive to resource values, and be consistent with the biological and physical conditions which exist in the field.

#### LITERATURE CITED

- Christner, J. and R.D. Harr. 1982. Peak streamflow from the transient snow zone, western Cascades Oregon. pp. 27-38. In: B.A. Shafer ed. Proc. 50th Annual Western Snow Conference. Reno, Nev. April, 19-23, 1982.
- Clark, R.N., R.W. Koch, M.L. Hogans, H.H. Christensen, and J.C. Hendee. 1984. The value of roaded, multiple-use areas as recreation sites in three National Forests of the Pacific Northwest. U.S.D.A For. Serv., Pac. NW. For. and Range Exp. Stat., Res. Pap. PNW-319. 40p.
- Cummins, K.W. 1975. The ecology of running waters; Theory and practice. Proc. Sandusky River Basin Symp. May 2-3, 1975. Tiffin, Ohio. 277-293p.
- Franklin, J.F. and R.H. Waring. 1979. Distinctive features of the northwestern coniferous forest: Development, structure and function. pp. 59-86. In: R.H. Waring ed. Forests: Fresh Perspective from Ecosystem Analysis. Proc. 40th Ann. Bio. Col., Oregon St. U. Press, Corvallis, Oregon 199 p.
- Froelich, H.A. 1973. Natural and man-caused slash in headwater streams. Loggers Handbook. 33:15-17, 66-70, 82-86.
- Guenther, K. and T.E. Kucera. 1978. Wildlife of the Pacific Northwest: Occurance and distribution by habitat, BLM District and National Forest. U.S.D.A. For. Serv., PNW Regional Office. Portland, Ore. 128 p.
- Harr, R.D. 1976. Forest practices and streamflow in western Oregon. U.S.D.A. For. Serv., Pac. N.W. For. and Range Exp. Stat., Gen. Tech. Rep. 49. 18 p.
- Harris, L.D. 1984. The Fragmented Forest. Univ. Chicago Press, Chicago, Ill. 211 p.
- Hawkins, C.P. and J.R. Sedell. 1981. Longitudinal and seasonal changes in functional organization of macroinvertebrate communities in four Oregon streams. Ecology 62(2):387-397.
- Hynes, H.B.N. 1975. The stream and it's valley. Verh. Internat. Verein. Limnol. 19:1-15.
- Keller, E.A. and F.J. Swanson. 1979. Effects of large organic material on channel form and fluvial process. Earth Surf. Proc. 4:361-380.
- Meehan, W.R., F.J. Swanson and J.R. Sedell. 1977. Influences of riparian vegetation on aquatic ecosystems with particular reference to Salmonid fishes and their food supply. pp. 137-145. In: R.R. Johnson and D.A. Jones eds. Importance, Preservation and Management of Riparian Habitat: A Symposium. Tucson, Ariz. July 9, 1977. U.S.D.A. For. Serv., Rocky Mtn. For. and Range Exp. Stat., Gen. Tech. Rep., RM-43, 217 p.
- Strahler, A.N. 1957. Quantitative analysis of watershed geomorphology. Am. Geophys. Union Trans. 38:913-920.
- Swanson, F.J. and R.L. Fredricksen. 1982. Sediment routing and budgets: Implications for judging impacts of forest practices. pp. 129-137. In: F.J. Swanson, R.J. Janda, T. Dunne and D.N. Swanston eds. Sediment Budgets and Routing in Forested Drainage Basins. U.S.D.A. For. Serv., Pac. N.W. For. and Range Exp. Stat., Gen. Tech. Rep., PNW-41. 165 p.



# Dividing the Water: Basic Precepts of Colorado River Water Law<sup>1</sup>

David L. Wegner<sup>2</sup>

---

The extent of riparian vegetation development along the rivers and streams which comprise the Colorado River System is a function of a myriad of legal and operational factors. The utilization of Colorado River water can be identified with several key issues, federal acts, and treaties. This paper will outline the major arguments and perceptions which define the present day levels of water and hence the extent of riparian vegetation along the river corridors of the Colorado River System.

---

## INTRODUCTION

The "Law of the River" as applied to the Colorado River, has evolved out of a combination of both Federal and State statutes, inter-state compacts, court decisions, contracts, an international treaty, operating criteria, and administrative decisions. The cumulative effect of all these apportionments have defined the development and extent of the riparian vegetation along the river corridors of the Colorado River System.

The Colorado River begins its journey in the mountains of Colorado and flows nearly 1400 miles before it terminates in the Gulf of California. The Colorado River is the second longest river in the United States and holds the dubious distinction of being the most closely regulated of the major rivers. The 900 mile long basin can be separated into two distinct basins: the Upper Basin, consisting of portions of Wyoming, Colorado, Utah and New Mexico; and the Lower Basin, consisting of portions of Nevada, Arizona and California. Numerous Federal, State, and private water projects utilize the river basin water both directly and indirectly. For the period of time from 1976 through 1980, the states of the Colorado River Basin collectively utilized over 15 million acre-feet of water (BOR, 1984).

The main objective of this paper is to outline the legal and operational decisions and constraints which define the flow levels that have shaped and continue to regulate the extent of the riparian community.

Prior to exploring the law of the Colorado River, it is necessary to understand the underlying logic which defines Western water law. Specifically, the "appropriated right" to water and the perceived necessity to hold the right to water use have defined the entire development of water in the West. When the first settlers made their way into the Basin, they quickly realized that the key to development and control centered around who had the ultimate control of the water. In contrast to the water law of the East, the developers initiated a reservation system of water that defined that use had to be beneficial to development and in most cases led to complete diversion from the river channel. Since water was of very limited supply, the user had to hold a legal right to beneficially utilize the water. The right was allocated on a first in time logic and as such the first ones on the scene laid claim to the primary use of the water and were defined as the "senior" water right holders. The initial users of the river generally gained the major control of the water resource. With this basic concept in mind, the remainder of the paper will outline some of the major development issues associated with the Colorado River.

---

<sup>1</sup>Paper presented at the North American Riparian Symposium. Tucson, Arizona, April 16-18, 1985.

<sup>2</sup>Grand Canyon Study Manager, U.S. Bureau of Reclamation, Division of Water and Land, Salt Lake City, Utah 84147

## EARLY DEVELOPMENT (PRE-1900)

The first non-native irrigators in the Colorado River Basin were the Jesuit missionaries in the Tucson area around 1732 (U.S. Dept. Int., 1946). After the Civil War had ended, a number of people began to move into the Colorado River Basin and specifically the California and Arizona areas.

Thomas Blythe recorded the first use of Colorado River water for irrigation purposes in the Palo Verde Valley in 1856 (U.S. Dept. Int., 1946). By 1877, Blythe made the first legal filing for Colorado River water in California. Within this same time period of the late 1800's, the Mormon pioneers were developing and designing extensive irrigation works in Wyoming, Colorado, and Utah. By 1883, the Grand Valley Canal had been built and was supplying irrigation water to a large area of the Western Slope area of Colorado.

## 1900 TO 1925

In the history of the Colorado River water development, the early 1900's were the most significant. During this period, the use of water in the Lower Basin had reached the maximum possible without the development of extensive storage and regulation. The passage of the Reclamation Act of 1902 signaled the beginning of the investigations into to feasibility of building large regulation and irrigation works in the West. Several reports and studies were conducted and analyzed. Several of these plans led to the development of the modern day Bureau of Reclamation.

By the 1920's, the development of the Upper Basin was considerably lagging behind that of the Lower Basin. However, mainstem development in both basins was impeded by the lack of storage facilities, water shortages, and the continual threat of floods and the aggravated siltation problems. During this time period, several public and private agencies and groups were seeking the rights to develop hydroelectric power and were proposing to provide storage and flood control on only an incidental basis. These recommendations were analyzed, but the Upper Basin states regarded any development in the Lower Basin as threatening to their established priorities to the water and could preclude future use of the resource. The states thought that they should control the use of water within their own states, but the Federal government claimed the ultimate jurisdiction over the water based on it being an interstate waterway. Some form of agreement was obviously needed before any comprehensive development of the Colorado River Basin could proceed. The Lower Basin favored a compact because they desired to enlist the support of the Upper Basin states in securing federal legislation for mainstem development. The Upper Basin states favored any type of decision which would secure their rights to future development of the water. These concerns and hopes were consummated through the development and passage of the Colorado River Compact in December of 1922. The division point between the basins was set at Lees Ferry, Arizona and it was determined (based on existing annual flow information) that the Upper Basin must guarantee to the Lower Basin states, an aggregate of 75,000,000 acre-feet of water for any period of ten consecutive years. The passage of the Colorado River Compact cleared the way for legislation that authorized the construction of major water projects and removed a major cause of rivalry between the two basins.

With the passage of the Compact, the Lower Basin immediately took advantage of several studies investigating mainstem storage and irrigation. The Kincaid Act (1924) and the Fall-Davis Report (1922) documented the need for flood control and storage to provide water for the Imperial Valley of southern California (U.S. Dept. Int., 1978). Out of these studies, irrigation canals were recommended for the Imperial Valley and the need was seen to develop a storage dam in the Lower Basin. These and other recommendations led to the Federal government passing the Boulder Canyon Project Act in 1928. This Act provided for the building of Hoover Dam and the definition of the amount of water that California could legally utilize. To finance the project, irrigation and hydroelectric power contracts were initiated to repay the development over time. The major component of the Boulder Canyon Project Act, Hoover Dam, was completed in 1935.

The country of Mexico became concerned that the development in the United States would utilize all of the Colorado River water before it had a chance to get to Mexico. In 1944, a treaty was signed between the United States and Mexico to provide on an annual basis, a quantity of 1,500,000 acre-feet of water to be supplied to Mexico. The treaty required that Mexico construct a diversion structure and that the United States would build the Davis storage dam and reservoir for regulatory and flood control purposes.

In 1948, the Upper Basin States entered into a compact of their own defining individual state percentages of water available for development and established a commission to explore the potential for developing water and irrigation projects within the Upper Basin. After numerous studies and investigations, the federal government, at the insistence and pushing of the Upper Basin states, passed the Colorado River Storage Act of 1956. The major features of this act were to provide for the development of four major storage projects within the Upper Basin (Glen Canyon, Flaming Gorge, the three reservoirs of the Currecanti Unit, and Navajo); for the establishment of repayment contracts for the structures and for the future development of other storage and irrigation features within the basin. Glen Canyon Dam was initiated in 1956 and completed in 1963. The primary purpose of Glen Canyon Dam and Lake Powell is for the regulation of water to the Lower Basin and to provide for hydropower revenues for the Upper Basin.

As the main features of the Colorado River Storage Act were being built, the State of Arizona was pushing for the full recognition of their water rights and to restrict California from excessive usage of the the Colorado River water. California had been developing and expanding far faster than any other state of the Colorado River Basin and has been utilizing any excess water that was not utilized by the other states. This worried the other States and still is a sore point in regards to future development. Several legal scuffles over these rights and future usage were entered into

and led to the legal definition of how much water Arizona and California were legally entitled to. Once the legal aspects were resolved, the State of Arizona quickly pushed for the development and funding of the Central Arizona Project for irrigation and municipal and industrial water for the state. In 1968, the Colorado River Basin Project Act was passed which authorized the Central Arizona Project, defined priority rights, authorized the Navajo Generation Station, established the Mexican Water Treaty as a national obligation, and established the need to define operating criteria between the basins. Operating criteria were developed between the basins and were based on the legal needs of the Colorado River Compact, the Mexican Water Treaty, and the need to maintain parity between the levels of Lake Powell and Lake Mead.

#### SUMMARY

Water holds the key to the development of the resources of the Colorado River Basin. In very simplistic terms, it represents the "critical" element in any development that has occurred. The development of the riparian vegetation that occurs along the Colorado River Basin corridors, is the result of the amount of water that has historically and is currently available. The vegetation is regulated by the legal and jurisdictional cons-

straints which ultimately control the quantity and quality of the river water. To say that the development of the water resources of the Colorado River Basin is complex would be an understatement. Before any thought can be given to future changes that will occur along the vegetation corridors, it is necessary to understand the precepts and attitudes which define and limit the amounts of water available. This paper was not intended to define every decision point that has been reached in the regulation of the Colorado River. Instead the intent was to define the major decisions and logic patterns which shape the Colorado River of today.

#### LITERATURE CITED

- U.S. Department of the Interior. 1946. The Colorado River. Planning Report No. 34-8-2. 392 p.
- U.S. Department of the Interior. 1978. Updating the Hoover Dam Documents.
- U.S. Department of the Interior. 1984. Operation of the Colorado River Basin, 1983 Project Operation. 32p.

# Resolving a Classic Conflict: Threat to a Riparian Ecosystem in Oklahoma<sup>1</sup>

John S. Barclay<sup>2</sup>

---

Abstract.--A proposal to convert a mature riparian forest and floodway to a regional shopping center and residential area was approved by FEMA but blocked by citizen action and city enforcement of local ordinances. This report chronicles evolution of the conflict and examines factors for and against development. Concern over flood liability was a major influence in decision making. Apparent deficiencies in the existing legal and institutional framework for riparian areas were detected.

---

## INTRODUCTION

The biblical admonition "Remove not the ancient landmark, which thy fathers have set" (Prov. 22:28) could well apply to some mature riparian forests in contemporary times. A case in point resulted from a proposal a little more than a year ago to develop a regional shopping facility and residential areas on an undisturbed riparian site owned by one family since the late 1800's. The growth-oriented Oklahoma community was faced with an issue that had major implications for both economic development and floodplain management. The community has rejected the proposal and the site remains intact. That outcome could not have been predicted and has been challenged in court by the developers. Nevertheless, the experience has provided insights into the responsiveness of existing bureaucracies and publics that should be of interest in similar circumstances elsewhere in the United States.

The purpose of this paper is to use the salient events to develop recommendations for surmounting similar conflicts in the future. For example, one key element of this conflict was the possible legal challenge to local watershed work agreements between conservancy districts and their cooperators under Public Law 566. An effort has been made to avoid identities and impartially assess the conflict without compromising litigation in progress.

The efforts and assistance of Helen Gorin, Helen Miller, Jack Bantle, John Couch, Jr., Robert Murphy, Jr., and Scott Shalaway; the members of the Coalition for Action on Resources and Environment (CARE); city and agency staff people; members of the Payne County Audubon Society (LAS) and other conservation and civic groups; and the many private

citizens who participated, pro or con, are acknowledged with appreciation and respect.

## THE SETTING

The events took place in a relatively isolated community of 35,000 people in the rolling oak/bluestem parkland ecoregion (Bailey 1976) of the southern Great Plains.

The moderate climate of the area is deceptive. The weather can be severe, with temperature and precipitation extremes dictating biota performance (Bailey 1976). Precipitation events can be of particular concern, for prolonged drought may end with downpours that create hazardous flash flood conditions (Barclay and Dunbar 1973:9). Major flood events occurred in the late fifties and mid-seventies (Corps of Engineers 1968).

The narrow meandering stream which flows, southeastward past the community drains 390 k<sup>2</sup> of watershed upstream (SCS 1962). The intermittent flow averages less than 5 cfs but was estimated at 35,000 cfs on 12 October 1959 (Corps of Engineers 1968). Roughly two thirds of the watershed is protected by two major impoundments, a dozen smaller PL566 floodwater retarding structures, and several hundred farm ponds. The largest impoundment, with a 1,335 ha flood pool, has an earth filled dam completed in 1939 without flood control devices.

The primary development tract of 65 ha has been owned by the same family since the late 1800's and contains approximately 37 ha of bottomland forest. The tract in question, plus some adjoining riparian properties, is unique for its longtime freedom from major disturbance such as grazing, its large-sized trees, and the extent of its contiguous riparian forest in close proximity to the city.

Most of the proposed development area would be classified under the U.S. Fish and Wildlife Service National Wetlands Inventory system (Cowardin, et al., 1979) as palustrine forested wetland, temporarily and/or seasonally flooded, broad-leaved

---

<sup>1</sup>Paper presented at The First North American Riparian Conference (Tucson, Arizona, April 16-18, 1985)<sup>2</sup>

John S. Barclay, Associate Professor, Department of Zoology, Oklahoma State University, Stillwater, OK 74078.

deciduous. A representative of the U.S. Army Corps of Engineers (ACE), visited the site in March 1984 and indicated that only two small areas within the tract would qualify as wetlands under current regulations.<sup>3</sup> The site is shown on the District navigable waters map as being a non-navigable headwaters area, subject to assumption of discretionary authority by the District Engineer (Federal Register 1975:31321).

A survey of the flora and fauna on the area (Barclay and Dunbar 1973) indicated high species richness and diversity. Dominant trees included unusually large bottomland hardwood species. Pawpaw (Asimina triloba), which is usually found as an understory plant in the eastern deciduous forest, is found on the tract and constitutes a record for the county. Cardinal flower (Lobelia cardinalis) is present on the site and, though widespread elsewhere, is uncommon in the area.<sup>4</sup>

White-tailed deer (Odocoileus virginiana), coyote (Canis latrans), bobcat (Lynx rufous), and beaver (Castor canadensis) are among the larger mammals found on the area. Fifty seven species of birds were found on, or adjacent to, the site in March, 1973. Forty bird species were found in the riparian forest where a diversity index value (d) of 4.2 was obtained (Barclay and Dunbar 1973).

Site disturbance had been increasing in recent years, particularly from cutting of fuelwood and gradual enlarging of adjacent fields by a farmer. Some hunting and trapping had occurred but public access had been discouraged by the owners. Several major residential developments and a regional vocational-technical school had been constructed on nearby properties to the south and west within the past 15 years. Commercial and residential areas 1 k to the east mark a transition to urban community. Several tentative efforts to preserve the site during the 1970's were unsuccessful.

#### Floodplain Zoning

Major floods in 1958 and 1959 were responsible for the city's entering into a Watershed Workplan Agreement as a "sponsoring local organization" (Soil Conservation Service 1962). The city, the local Conservancy District, and three other districts were signatories to the agreement with the USDA Soil Conservation Service. The agreement, among other specifications, required that:

"The city of Stillwater and the Conservancy District will zone the area flooded by the 100 year frequency storm with project installed from State Highway 51 downstream to the confluence of Boomer Creek ... The zoning will prevent new construction (dwellings or

<sup>3</sup>Carpenter, L. 1984. Personal conversation. U.S. Army Corps of Engineers, Navigation Division, Tulsa, OK.

<sup>4</sup>Worsham, E. 1984. Personal conversation. Botany Department Herbarium, Oklahoma State University, Stillwater, OK.

business) in this area. Structural measures to protect this area will not be constructed until zoning ordinances are provided." (SCS 1962:29).

After further discussion and a final decision on the boundaries of the zoned area, the zoning requirement was met (Harmon 1964; Anon. 1964).

Since the watershed project is not yet complete, the Work Plan, hence the zoning agreement, is still in force and functions as the means by which the directives of PL566 are implemented.<sup>5</sup>

The city has known a variety of floodplain and land use zoning regulations, amendments and variances. The latest ordinances were based on 1979 Federal Emergency Management Agency (FEMA) maps updated in 1982. The final ordinance, amended, states that "variances shall not be issued within any designated flood way" (City of Stillwater 1982, 1983). The FEMA maps show that most of the area proposed for development was in the floodway.

#### Development Proposal

The basic proposal called for construction of a 500,000 sq. ft. enclosed two-story shopping mall plus 1900 parking spaces totaling 15 ha. Later development would encompass 65 ha and feature estate-type homes, 200 single-family residences and duplexes, and commercial development of two other tracts. The pre-project publicity stated that landscaping and retention of a natural setting would be a priority and that "only the trees that really need to be removed to give way for construction work will be chopped down" (See 1984).

Before construction could begin, approximately 3 km of two stream channels which join on the area were to be rechanneled into a shorter (1.25 km), wider, and deeper (5.2 m) structure designed to carry a 100-year-frequency flood with a 46 cm freeboard. In order to avoid increasing discharge downstream, roughly 900 acre feet of water would be stored in three retention areas, most of which would be created on nearby university and private properties. Fill would be obtained from the university land, the resulting excavations to be used as retention ponds. A tributary along the south border of the property and entering the main stream just below the development would also be modified.

The project was to be built south of a four lane divided highway which is constricted by two bridges midway along the north boundary of the area. A standard hard surface road along the west boundary was to be modified as part of the development to accommodate the predicted 60 percent increase in traffic. Project consultants expected 10,000 cars per day for the site.

<sup>5</sup>Gorin, H. and J. Barclay. 1984. Personal correspondence. Coalition for Action on Resour. and Envir. Stillwater, OK.

## Pro-Floodplain Concerns

The many concerns expressed by those favoring retention of the floodplain zoning status can only be highlighted here. They include:

- \* the social and economic consequences of permitting a major development variance, reversing 22 years of precedent in establishing a comprehensive flood plain management program;
- \* the flood risk inherent in removing natural flood retention area from floodway, downstream from a large high hazard dam and an urbanizing watershed otherwise only partially protected by flood control structures;
- \* the substantial loss of mature undisturbed riparian habitat, stream channels, and associated flora and fauna, within a rapidly urbanizing environment;
- \* substantial reduction of the physical, biological and visual amelioration provided by the natural riparian buffer between the city and prevailing southwesterly winds;
- \* costs inherent in accommodating the proposed commercial development (plus others awaiting outcome of this project) where the present transportation systems are inadequate;
- \* taxpayer responsibility for maintenance of the proposed flood conveyance and storage structures, plus liability in the event of flood due to project design.

## EVOLUTION OF THE CONFLICT

The proposed development quickly evolved into a major local issue, perhaps partially as a result of the 21 Feb. public information meeting. Subsequent compromise efforts fell through and later events polarized the issue. A review of the events suggests a sequence of conflict phases.

### Proposal Phase

City officials learned of the development proposal when it was presented to a gathering of city officials and business leaders. Public unveiling occurred later by means of newspaper articles (Anon. 1983; See 1984).

Concern about the consequences to the riparian forest and to local flood control efforts led to consideration of the issue by the local chapter of the Audubon Society (LAS). A statement of concerns was prepared and distributed at a public information meeting on 21 Feb. 84 in the city municipal building. Although no applications for a floodplain zoning variance had been made, it was explained at the meeting that preliminary site and structure engineering plans had been prepared, along with market and traffic surveys.

## Reaction Phase

Aware of the environmental issues concerning the proposal, an owner of property 1.5 k from the site made a tentative verbal offer to sell acreage for the shopping center to the developers and to buy the riparian tract for donation to the city. The author met with the developers, described the offer and reviewed alternatives. Environmental problems and the possible flood-related consequences of proceeding with the original site development were discussed.

No direct contact between the developers and the alternative owner was made. Instead, the current site owner contacted the author for information, clarification as to the opposition, and to express his concerns. He indicated that the developers had a purchase option which could not be voided unless the project plan proved to be impossible on an engineering basis only. The option was to expire 1 July 84, and the owner expressed willingness to sell the 65 ha to any buyer for \$450,000 at that time.

The development plans were submitted to the city in mid-April and the pace quickened. On 23 April local citizens met to discuss the situation. Surprise attendance at the meeting by the developers led to discussion which confirmed their rejection of the alternate site.

The citizens group decided unanimously to form a "Coalition for Action on Resources and Environment" (CARE), taking no stand on a shopping mall per se, but to "inform and alert the public to natural resource management decisions and problems and how they affect life in our community" (Barclay 1984). CARE's first task was to address the potential breach of the PL566 floodplain agreement, coupled to the city's floodplain ordinance, and the hazards of major development in a floodway. A leaflet and news release were prepared and disseminated.

### Confrontation Phase

Chainsaws and bulldozers operated by the developers began clearing mature timber and altering a channel on the site in full view of passing traffic on May 2. This, as the developers confided to a CARE member and later to the press (Anon. 1984) was essentially to demonstrate publicly their determination and right as private landowners to proceed with the project. Weekend rains halted the action for several days. CARE filed a temporary restraining order in District Court on 9 May and a hearing was set for the 17th. On the 10th, the developers' attorney sought and was granted a dismissal. CARE's attorney immediately filed a protest, and the court called a hearing on the petition. Following brief testimony the court announced that, if CARE posted a \$2,500 bond, the injunction would be activated and the interested parties could meet again in court on the 14th. While CARE members considered financing possibilities, the land clearing continued, sans injunction and sans permit, for another day.

The next afternoon (May 11) the author was notified that the city had decided to support CARE's

position. After input from FEMA, a cease and desist order, at first ignored, was finally adhered to by the developers upon threat of enforcement. The clearing was halted but not before several acres of large trees were gone, one minor channel was modified, and the soil exposed.

#### Entrenchment Phase

Both sides awaited the "Belief Letter" from FEMA, but no one expected it would be negative. Two CARE members made detailed presentations to the local Conservancy District Board and the County Conservancy District members on 8 May. The CARE chairman sent a letter to FEMA, detailing concerns, requesting denial of "belief", and calling for an environmental assessment under NEPA.<sup>6</sup>

On 16 May a "special" unpublicized meeting was held between the local district board members and the mayor, city commissioners, city staff and attorneys to review the situation, particularly in regards to the 1964 floodplain zoning agreement. The attorneys were instructed to see if and how the agreement could be amended. Their decision was to await the FEMA letter. If favorable, they would then contact parties to the agreement to proceed in getting an amendment.<sup>7</sup>

A Conditional Belief Letter dated 21 June from FEMA's Washington, DC office conveyed belief that the project would comply with agency specifications, given some further design adjustments. However, FEMA made it clear that if the city granted the zoning variance, all liability would be on the city, not the developers or FEMA.

Although efforts to obtain an amendment to the 1964 zoning requirement proceeded, attention shifted to a new aspect. A new drainage ordinance, incorporating Urban Drainage and Flood Control Criteria Manual and Handbook, was nearing completion. The new ordinance emphasized the policy of leaving undeveloped floodplains in their natural state. At a city commission meeting on 16 July, one agenda item was to consider the FEMA letter. At least one city staff specialist expressed opposition to the "massive change in the floodplain" which would result from the rezoning for development.<sup>8</sup>

#### Resolution Phase

Pro-development interests prepared a draft amendment based on the 1962 Watershed Work Plan Agreement which stated in part that, "The watershed work plan may be amended or revised and that this agreement may be modified or terminated, only by mutual agreement of the parties hereto." On the basis of reports that parties to the agreement were being contacted with respect to amendment, CARE

<sup>6</sup> Barclay, J. S. 1984. Personal correspondence. 18 May. Stillwater, OK.

<sup>7</sup> City Clerk, 1984. Minutes, City Commission Meeting 25 June. Stillwater, OK.

<sup>8</sup> Couch, J. 1984. Personal correspondence. John Couch, Jr. Law Office. Stillwater, OK.

countered by providing conservancy districts with information outlining reasons for opposing the amendment.

The matter finally came to a head in October 1984 with a formal request by development interests for the city to amend the SCS Work Plan Agreement. A request for rezoning of the area in question from floodplain and agriculture to commercial was also made. Both matters were scheduled for a public hearing before the city commission meeting on 22 Oct. 84. A motion to defeat the amendment, killed by a vote to table for one week, followed the hearing (Fuqua 1984). The next day (23 Oct.) the conservancy district board members voted against the amendment by a narrow margin (3-2) (Pease 1984). The board's decision was supported the following week when the commission voted 4-1 against amending the 1964 agreement (Fuqua 1984).

The rezoning hearing, having been delayed, was reset for 12 Nov. Prior to the hearing, city staff recommended in their report to the commissioners that the "land area subject to this hearing be maintained in its present zoning classification, and that this request be denied."<sup>9</sup> That recommendation subsequently was upheld.

The issue appeared to have been resolved. However, on 21 Dec. 84, a civil suit was filed by the developers in U.S. District Court naming the City and its commissioners, the conservancy districts, and the United States of America. The plaintiffs called for combinations of declaratory, injunctive, equitable and legal relief plus damages including a sum of approximately \$40 million. This relief was requested on the premise that the defendants caused damages to the plaintiffs by failing

"to afford proper zoning to property which the plaintiffs have an interest (sic) in which has effectively constituted a taking of the Plaintiff's property without due process of law contrary to the Plaintiff's Fifth and Fourteenth Amendment Rights and have denied the Plaintiff Equal Protection of the Law" (Bullock 1984).

A motion to dismiss the suit was filed by the city in March 1985. The matter rests at that point as of this writing.

#### ANALYSIS: FACTORS OF CONFLICT

##### Pro-Development Factors

The pro-development interests effectively utilized the elements of surprise and boldness to establish momentum. The merit of using technically qualified and widely respected consultants, evidently well practiced in bureaucratic strategy, was also noteworthy.

The project was widely promoted via media interviews, excellent planning documents, and

<sup>9</sup> Gambill, B. 1984. Report to Commission. No. 300-84, City of Stillwater, OK, Nov. 1 p.

other less virtuous techniques. The economic aspirations of the community were correctly targeted, a concept based on imagination and technical design being sold that promised enormous returns for relatively low investment. However, the net result of these efforts seemed to be general public confusion.

The developers personal, emotional and economic involvement with the project and the property itself may have proved to be a disadvantage. Family ties to the property may have resulted in the unawareness of the high natural values of the site. Since the owners were part of the proposal package, it may not have been feasible to opt for an alternative site.

Several features of the community aided the proposal. Business support was mixed in that some downtown businesses perceived the threat of a major shopping center on the outskirts, while major investors recognized some bright opportunities. Once rezoned, nearby floodplain areas also could be developed quickly.

Some community elements, e.g. the media, were pro-development. Once the issue was joined and became "newsworthy", the media (somewhat reluctantly) covered events as they transpired from the pro-development standpoint.

The city administration and the public were both slow to respond openly. Uncertainty as to implications of ordinance specifications may have been a factor. The city had a long history of granting floodfringe variances; and little enthusiasm for opposing well-financed development.

The general public responded to the appeal of a major shopping center. Many failed to perceive its location despite the publicity. Some, who knew the location, thought it a poor site but would not speak out due to family, business or political connections. Others expressed fear of reprisal in their employment locally. The resulting ambivalence and apathy did nothing to alter pro-development effort.

The inability or lack of enthusiasm from some state and national agencies and private organizations to provide assistance hampered opposition efforts to gain public support. The two notable exceptions were the Ecological Services Field Office, U.S. Fish and Wildlife Service, and the state chapter of The Wildlife Society (OTWS). The former provided technical assistance and sent a letter<sup>10</sup> to the District Engineer, ACE, in support of the LAS formal request<sup>11</sup> for the Corps of Engineers to utilize its discretionary authority in the matter under

<sup>10</sup>Wilkerson, S. 1984. Personal correspondence. Office of Ecological Services, U.S. Fish and Wildlife Service. Tulsa, OK.

<sup>11</sup>Shalaway, S. 1984. Personal correspondence. Payne County Audubon Society. Stillwater, OK.

<sup>12</sup>Teels, B. 1984. Personal correspondence. Oklahoma Chapter of The Wildlife Society. Stillwater, OK.

Section 404 of the Clean Water Act. No written response was received to either letter. TWS provided technical assistance and a formal letter of support<sup>12</sup> (Teels 12 Jun. 84) to CARE. Other than those exceptions, requests for assistance from state and national offices of conservation organizations proved fruitless.

Pro-floodplain supporters soon learned that state and federal agency mandates were simply too broad for dealing with specific floodplain development proposals upstream from "navigable waters" designation. If the city had not had an updated, tightly worded floodplain ordinance, coupled to the all but forgotten 1962 PL566 Watershed Work Agreement, the project would not have been blocked.

No one, regulatory agencies included, ever acknowledged the ironic contradiction of compromising the intent of established regulation (floodplain/floodway protection) via design compliance and development (dredge and fill) before granting a zoning variance once a site had been technically, if not literally, removed from floodway designation. The developers had assurance that they were in regulatory compliance, but they could not dispel the realities of flooding, most especially liability, which this contradiction imposed.

#### Pro-Floodplain Factors

One would like to think that sound reasoning and factual information on floodplain management convinced the decision makers to vote as they did against the project. It is clear, however, that other factors were operating, not least of which was the willingness of some dedicated local citizens, collectively knowledgeable as to floodplain regulations and management, to confront the issues publicly.

The pro-floodplain effort consumed inordinate amounts of voluntary time, effort and resources. These contributions became much more effective with formation of the coalition (CARE). The value of a centralized forum was quickly realized when the decision to file an injunction was made. The coalition had an identity but also anonymity, was able to receive and disburse funds, and could vocalize information for use by the public and officials alike.

The willingness of CARE to go to court when necessary demonstrated conviction and determination. Resulting media coverage, although biased, caught the public's attention and open consideration of project alternatives became possible. The city's commendable and timely enforcement of its existing floodplain ordinance, given FEMA clarification and support, provided the injunctive relief sought. If the land clearing had not been halted at that point, some natural riparian attributes would have become a moot point.

Despite statements presumably meant to disarm those with environmental concerns, a patently uninformed approach to riparian concerns and a cavalier attitude about natural versus



designed landscapes merely antagonized. The pro-development group seemed to be ignorant of the strength and quality of concern in their opposition. They also failed to enlist environmental talent, especially biologists, with intimate knowledge of the local area. The exceptional flood retention value of the site, the upstream concerns, and the major water absorption, storage and transpiration virtues of the mature timber, were overlooked or dismissed by developers and regulatory agencies alike.

Two related factors, the Conditional Belief Letter from FEMA and the impending new floodplain ordinance and manual, also appear to have been instrumental in the pro-floodplains decision. The importance of leaving floodplain undisturbed had been articulated, reinforced by public sentiment; and FEMA had placed liability for floodway development squarely upon the shoulders of the city.

#### Tulsa Flood

"...According to federal officials, the City of Tulsa has one of the most comprehensive sets of flood control ordinances in the nation. Adopted in the late 70's, they went as far as those of any community, and they exceeded federal requirements..." (Pearson 1984). Between 1974 and 1984 Tulsa spent \$46 million in public funds, \$22 million in the Mingo Creek Basin alone. Private funds added substantially to the effort.

On 27 May, 1984, downpours devastated the Mingo Creek area of the city. The flood killed 14 people in what was described in one account as a "500-year deluge". The Pearson (1984) account informed Tulsans that ... "use of the term '100-year flood' - you know, the kind we have every five years or so - may be discontinued, because it is misleading and lulls many into a false sense of security. At least one official has called for finding a new way to describe the phenomenon."

Tulsa officials imposed a moratorium on property restoration in order to assess the damage. Shortly afterward the city initiated procedures to buy out 284 flood-damaged homes at a cost of \$16 million dollars (Pearson 1984). The message was not lost in other communities in Oklahoma and gave fresh impetus to CARE's opposition to an 80 ha development in the floodway of a natural flood retention area.

#### CONCLUSIONS AND RECOMMENDATIONS

If development conflicts are to be minimized the interests of all parties must be determined and addressed before serious financial, or emotional, investments are jeopardized. The inherent values of natural floodplain resources are just as real as are investment opportunities, both to individuals and to a variety of publics. However, conservationists and landowners, developers and consultants, must recognize that each may perceive the same mountain from a very

different perspective, and that each perspective has its own merit.

A number of deficiencies were encountered in the existing legal framework for protecting riparian areas. Federal, state and local regulations are supposed to protect floodplains, particularly floodways, to prevent or reduce flooding by maintaining a natural state. Too often this "protection" is a gross public deception. It is contradictory to zone floodplains against development, but allow development and grant variance after the fact, simply because the best engineering models or data have established no adverse affect on estimated 100 year flood levels. The "100 year flood event" is occurring with absurd regularity (the Tulsa flood in 1984 is one example). Floodplains are for flooding and, as development intensifies in our watersheds, major flood events are likely. The legal emphasis should be on protecting the natural attributes of floodplains.

A renewed focus on non-point source pollution by the Environmental Protection Agency and state water boards may be warranted when reviewing floodplain developments which are allowed. Such aspects as sediment released by construction activities, unprotected soils during land clearing and shaping, and inadequate attention to possible contaminants in runoff from non-porous surfaces (e.g. parking lots, roofing) are examples.

Present FEMA mandates apparently preclude consideration of upstream conditions (e.g. land use changes and development, impoundment hazards) which could affect flood levels but are not required in development site flood proofing specifications.<sup>13</sup> The FEMA review should require more than just on-site considerations.

Riparian vegetation transpires and stores substantial quantities of water during the growing season. Even when dormant or dead, vegetation performs valuable functions by absorbing overland flow energy, inducing sedimentation, and moderating flood peaks and discharge. These components should be considered and included if appropriate in establishing development site impacts.

In the 404 program, as well as other agency floodplain mandates and regulations, real problems are found in terms of application at the grassroots where the real gutwrenching decisions have to be made. This is especially true for many so-called "intermittent" or "ephemeral" stream riparian areas above the "navigable waters" designation. Headwaters riparian zones should be re-examined and critical areas be classified and mapped accordingly.

If there is a lesson to be learned from this experience, it is the reminder that even good laws don't work without people to back them up ... and good laws, like good people, don't happen overnight. Citizens in every community should examine, understand and monitor local

<sup>13</sup>Mrazik, B. 1984. Personal correspondence. Federal Emergency Management Agency, Washington, DC.

floodplain programs and regulations.

Community officials, planners and decision makers are often on a tightrope between opposing floodplain interests. Better support from an educated public would make their decisions easier and more effective.

Much of the information now available on floodplain values and management has not filtered into the minds of the general public. Simplified but appealing information features need to be prepared and released by federal and state agencies and national organizations for use in elementary and high schools. The media can perform a valuable service by using quality features dealing with local riparian issues whenever possible. These could be best supplied, with pictures, by local conservation groups.

If, as so many private conservation groups proclaim, floodplain conservation is important to our society, then these national organizations would do well to examine their own infrastructure for addressing local problems. If grassroots membership is essential to these groups, then being able to respond appropriately to the needs of members at the grassroots should be no less critical.

Coalitions can be very effective in helping to resolve local environmental concerns. Given the likelihood that a coalition could be needed, local organizations should take steps ahead of time to establish contact and develop support mechanisms before they are required.

#### LITERATURE CITED

- Anonymous. 1964. New area floodplain map given to watershed assn. Stillwater Newspress, 19 October.
- \_\_\_\_\_. 1983. Galleria shopping center set for Sangre, S. H. 51 location. Stillwater Newspress. 25 December. p. 1.
- \_\_\_\_\_. 1984. Galleria cast chooses sides. Business Digest. 10 May.
- Bailey, R. G. 1976. Ecoregions of the United States. U.S.D.A. Forest Service, Ogden, UT 75 p.
- Barclay, J. S. 1984. We C.A.R.E. Coalit. for Action on Resour. and Environ. Leaflet. Multilith. 2 p.
- Barclay, J. S. and M. R. Dunbar (editors). 1973. The role of wildlife in the Stillwater Creek Greenbelt. Wildl. Mgmt. Tech. Class, Zoology Dept. Okla. State Univ., Stillwater. 119 p.
- Bullock, L. 1984. Case No. CIV-84-3369 R. U.S. District Court, Western District of Oklahoma. Legal brief filed 21 December. 14 pp.
- City of Stillwater. 1982. Ordinance no. 1980. Stillwater City Code 16(2):2 Sec. 16-28. Stillwater, OK.
- City of Stillwater. 1983. Ordinance no. 2093. Stillwater City Code (16)2:2 Sec. 16-28.3(D) Stillwater, OK.
- Corps of Engineers. 1968. Floodplains information, Stillwater Creek and Tributaries, Stillwater, Oklahoma. U.S. Army, Tulsa District. 63 p.
- Cowardin, L., V. Carter, F. Golet and E. LaRoe. 1979. Classification of wetlands and deep-water habitats of the United States. FWS/OBS-79/31. Washington, DC, 103 pp.
- Federal Register. 1975. Department of Defense, Corps of Engineers - permits for activities in navigable waters or ocean waters. U.S. Gov't. Pr. Office. 44(144):3120-3121.
- Fuqua, C. 1984. Commissioners delay Galleria Mall decision. Stillwater Newspress. 30 October. p. 1.
- \_\_\_\_\_. 1984. Commissioners nix Twin Oaks Galleria. Stillwater Newspress. 30 October. p. 1.
- Harmon, B. 1964. MAPC okays flood zoning after protest. Stillwater Newspress. 3 September. p. 1.
- \_\_\_\_\_. 1964. Watershed project bids will be opened on Nov. 30. Stillwater Newspress. 30 October. p. 1.
- Pearson, J. 1984. Flood control: good news, bad news. Tulsa World. 10 June. Section I. p. 1.
- \_\_\_\_\_. 1984. City dads fussing over Buy-Out. Tulsa World. 30 June.
- Pease, R. 1984. Galleria hits new snag. Stillwater Newspress. 24 October. p. 1.
- See, H. 1984. Developers announce plans for shopping mall. The Daily O'Collegian. 18 January. p. 2.
- Soil Conservation Service. 1962. Stillwater creek watershed project report. USDA/SCS. Stillwater, OK.

# The Florescence of Arid Lands in Mesopotamia, Elam, and Central Asia: An Historical Perspective<sup>1</sup>

Jeffrey Zauderer<sup>2</sup>

---

Abstract.--Great civilizations developed arid lands by the extension and management of artificial riverine systems to irrigate cereal cultivars. Areas formerly cultivated are today unproductive, due to the collapse of riverine management.

---

## INTRODUCTION

The broad framework for the development of urban societies, and their blossoming into great civilizations in arid and semi arid regions, rested upon the physical systems and social organizations for cultivating cereals (Adams 1969, Wittfogel 1971). Wild cereals grew in areas receiving 400-500mm rainfall (Raikes 1965), and are cultivated with less than 100mm. The course of arid land history is woven around the hydrologic and social management of artificially extended riverine systems into fine grained alluvium, allowing for the intensive cropping of more prolific introduced winter annuals (cereals), and the loss of more nutritious but less prolific winter annual legumes (Flannery 1971).

## IRRIGATED ARID LANDS

### Mesopotamia-Elam

#### Ecological Disturbance

Botanical.--Rainfed agriculture on steppes began with the introduction of highland cereals into cleared land. Such areas were often near marshes with Scirpus, and possessed good drainage (Hole, Flannery, and Neely 1969). Natural winter maturing vegetation was removed for crops, but contaminants such as Aegilops, Lolium, and Avena were also spread. Lolium is today a major lower Mesopotamian noxious weed (Helbaek 1963, 1969, Adams 1965). Native grass cover was replaced by Malva, Plantago, Fumaria, Gallium, Lathyrus and vetches.

The natural cover of winter legumes on alluvium, Astragalus, Trigonella, and Medicago, important food sources before cultivation of cereals, were removed. They exist on talus slope refugia sought by goats. Summer maturing plants, such as Prosopis, spread to the steppe and lower alluvium, becoming an important food source (Helbaek 1969); their summer transpiration helped lower excessive soil saturation (Jacobsen 1982). Zizyphus spread from upland forests after sufficient soil disturbance and soil saturation. It produces a small fruit eaten in

---

<sup>1</sup>Paper presented at the Riparian Ecosystems and their Management conference, April 16-18, 1985 at the University of Arizona, Tucson.

<sup>2</sup>Research Associate, Department of Arid Land Studies, University of Arizona, Tucson.

winter. The leguminous weed Scorpiurus was spread by Parthian or Sassanian irrigation (Helbaek 1969).

Spreading agriculture forced pastoralists to overexploit palatable species. With the appearance of domestic wool sheep, Stipa, a former forage plant for wild sheep, became a noxious weed spread by clinging to wool, and shunned because of its habit of burrowing into the sheep's skin (Flannery 1971). This put more pressure on the winter natural grass cover.

Salinity.--The effects of salinization and its historical occurrence are discussed in detail by Jacobsen (1982). The niches created by abandoned saline land greatly changed the Mesopotamian biota; the original perhaps only visible in pollen records (Flannery 1971).

#### Irrigated Civilizations

Lower Mesopotamia.--The great city states of Southern Mesopotamia depended upon canals fed by the Euphrates, and later, the Tigris. The system of settlements followed linear patterns formed by irrigation works. In Hammurabi's time there were 6 major canals, used also for defense and transport (Jacobsen 1960). The canals of Mesopotamia connected the city-states into a network of international trade. Hostile relations between states existed as a result of their efforts to accrete more land and water. Slavery for irrigation and agricultural labor seems to have been absent (Walters 1970).

The Neo-Assyrians.--The later Assyrian kings sought to develop the steppe and plains north and east of the Tigris: the Khosr system to Nineveh, along the Zab to Calah, and the Bastura to supply Erbil. Figure 1 shows Sennacherib's water supply to Nineveh and the royal estate at Khorsabad. Note the great diversion aqueducts and canals carrying water from the Atrush River and the waters from the Jebel al-Qosh. A storage dam above Nineveh was tapped by qanats into the city.

The land to the north and east of the Tigris at Nineveh receives more than 200mm rainfall, but the November rain is very unreliable. The Assyrians irrigated for intensive development beyond its former use and natural capacity. Sargon II (722-705 BC) writes of himself: "He vowed to open up fallow land and plant orchards; to gain a crop on steep rocky slopes; he set his heart into wasteland that had known no plough under former

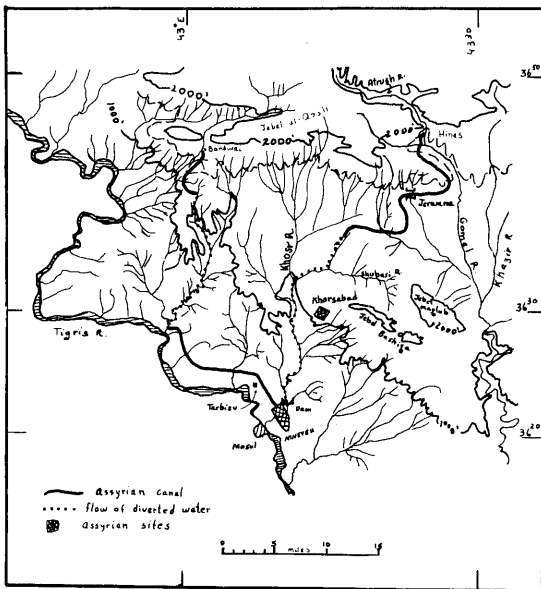

Figure 1.--Sennacherib's irrigation of Nineveh. (After Oates 1968, with topographic additions)

kings...'' (Saggs 1984). Nineveh is memorable for its vast gardens and orchards supplied in the hot summer by vast irrigation works. Winter water supplied grain and flax (or sesame) crops between Nineveh and Tarsisu (Oates 1968, Saggs 1984). The gardens contained artificial mountains covered with trees from Armenia: cypress, cedar, pistachio, stone fruit trees, mulberry, and pleasant herbs. Sennacherib also gave plots of land to citizens for orchard use (Luckenbill 1926). Cotton, also from the Ararat area was grown and woven into garments (Luckenbill 1926).

Sennacherib undertook similar works for Erbil: rechannelization of the Bastura tributaries, conducting spring discharge to the city, a qanat originating below the Bastura and discharging in the city, and a qanat from the foothills of Qala Mortka to Erbil (Safar 1947).

The Assyrian development strategy was bound to its military policies and drive to monopolize resources. Oates' (1968) study indicates that Assurnasirpal's development of Calah (ca. 879 BC) exceeded the local capacity of agriculture to support its population--orchards were grown at expense of grain. Surprisingly, date palms were cultivated, and oaks for the galls used in tanning. Herding was an important part of the economy, possibly extended by improved water supply. Sennacherib's Nineveh was similar (Oates 1968). The population was supported by the flow of tribute from the empire's periphery. Useful persons were deported to the capital, or settled in garrisons in buffer areas. The Assyrians deported over a million persons, who were given rights as citizens, although farmworkers were sold with the land they worked (Oded 1979).

**The Sassanians.** -- The Sassanian development of the Diyala Plain is shown in figure 2. Most of the land is not cultivated today (Adams 1965). Note the canals from the Tigris and the Jebel Hamrin, which are also pierced by a tunnel. Note, too, the diffuse linear branching pattern of settlement. Wenke (1978) found that in Susiana, the strategy was to concentrate the population into a great city, Gundishapur, thus leaving the arable land less populated, but heavily cultivated by large royal estates.

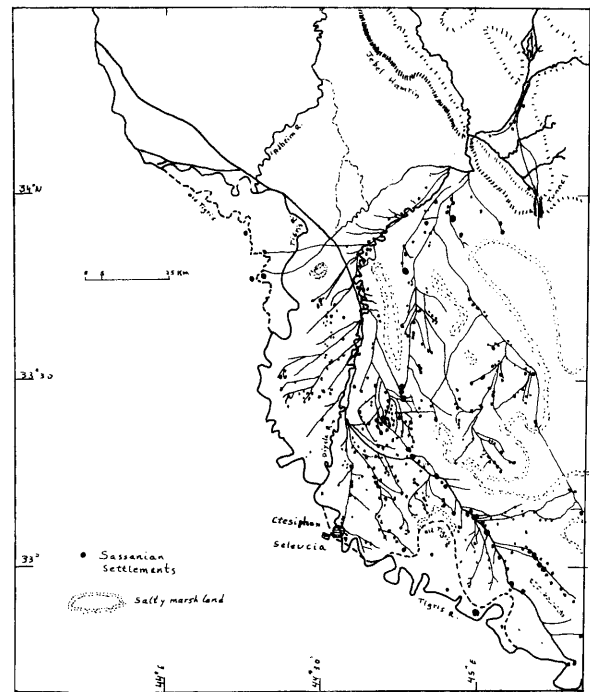

Figure 2.--Sassanian irrigation of the Diyala Plain. (After Adams 1965)

Wheat, barley and rice were main crops, and perhaps sugarcane was grown close to canals. In Deh Luran, qanats were used to tap alluvial water from the Mehme and Dawairij rivers. The piedmont zone was improved with retention dams and gabrbands. Captive Romans may have been used and settled. With time, the non-noble population became enserfed, leading to the Mazdakite revolts in the 580's. Reform granted varying degrees of freedom to improve worker productivity (Nomani 1976, 1977). The interior of Iran, with less than 50mm rainfall was opened to agriculture by the use of qanats. Yazd until about 1960 was still completely dependent upon the management of qanats--underground riverine systems (cf Bonine 1980).

## Central Asia

### Early Irrigation Civilizations

**Southern Turkmenia-Kopet Dag.**-- The pattern of urban development and agriculture follows the move down-slope with increasing irrigation as seen in Mesopotamia and Elam. Up to the I millennium BC the piedmont zone of the Kopet Dag and the Atrek, Sumbar and Chandyr valleys in the west were extensively irrigated with simple irrigation systems (fig.3). By the beginning of the I millennium BC complex irrigation with control structures and extensive branching extended onto the alluvial plains of the Murghab River, and the Misserian plain of the Atrek. Figure 3 geomorphic information from Dolukhanov (1980) and Babaev & Magtimov (1983) show the extent of ancient agriculture on the Atrek-Sumbar alluvial plain, which was very active in the II and I millennium BC. The predominate vegetation at that time was ash and elm. Irrigation, with interruption by wars continued into Timurid times; sometime by the 15th century AD the area became predominately saline desert (Babaev and Magtimov 1983). Qanats were in use in the early I millennium BC (Lisitsenia 1980).

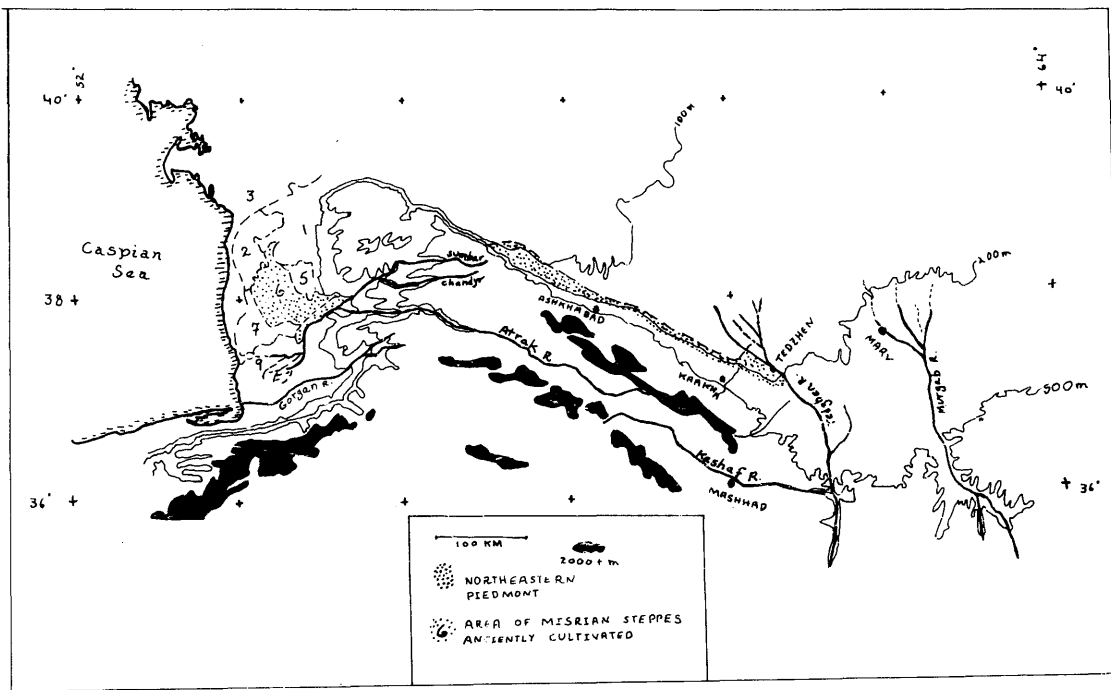

Figure 3.--The Kopet Dag region

**Khorezem.**--Figure 4 shows that the area up to the Syr Darya was from around the II millenium BC to the 13th Century AD populated and irrigated. Figure 5, the inset for figure 4, shows more detail: settlements following the myriad irrigation branches of the Amu Darya.

Khorezmian irrigation in the I millenium BC extended as far west as the Uzboy (Frumkin 1970). The rise and decline of its agricultural civilization follows the turns of empire. It is probably the area referred to in the Avesta (Masson and Sarianidi 1972). In the 6th Century BC the

Sakas and Achaemenids brought iron; irrigation expanded greatly, possibly with slave labor. The Greco-Bactrian period was another high. The Kushan period was very prosperous, declining with the clashes with the Sassanians. The Afrighid period, 4th to 5th century and the Hephthalites, who pushed out the Sassanians in the 6th century saw prosperity, until the advent of turkish nomads. Irrigation declined during the Arab invasion, and revolts against the caliphate. In the 10th to 13th centuries irrigation flourished, and the area of the Samannids was a world center of philosophy, commerce, tree fruits, mellons and famous gardens. Prosperity waxed through the Karakhanids, until Chengis Khan raided the area, and 170 years later, Timur devastated the region (Frumkin 1970).

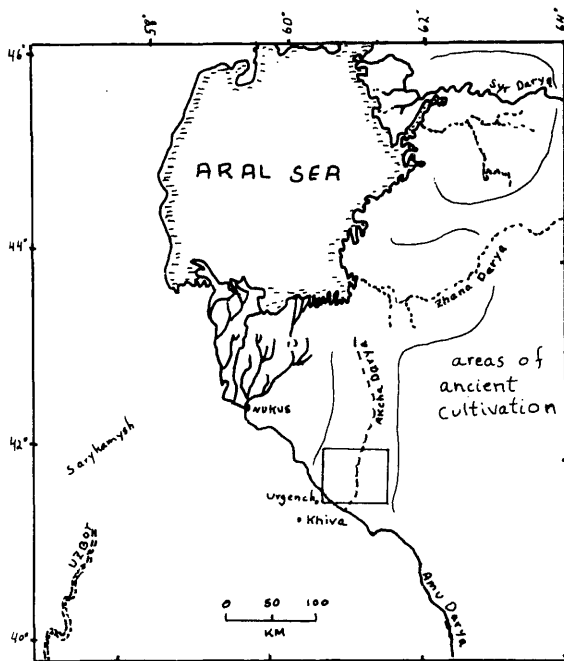

Figure 4.--Khorezem and the Syr Darya. (After Frumkin 1970)

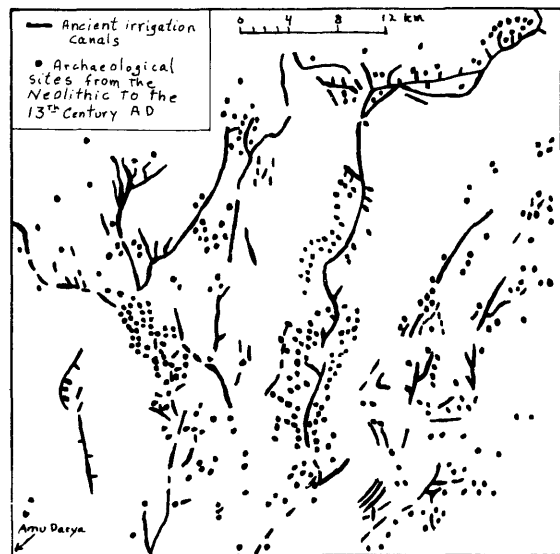

Figure 5.-- Inset in figure 4. Ancient irrigation and settlement in Khorezem. (After Frumkin 1970)

Khorezem and Turkmenistan are now covered with takyrs, Haloxylon, Scirpus, Artemisia, saltwort, and dunes that sometimes disclose the loamy humic horizons of buried civilization (Lisitsinia 1980, Dolukhanov 1980, Frumkin 1970).

#### Large Scale Interactions

##### Irrigation Collapse

Yemenite Agriculture.-- The civilizations of Rome, Persia and Yemen were powers in a world economy. Competitive Roman shipping had drawn away the supporting trade and capital of the caravan routes that provided the support for agriculture and irrigation maintenance. In the 3rd Century AD the Marib dam failed and the resulting flood and erosion of thousands of hectares of arable land hastened the process of bedouinization (Caskel 1954). The displaced tribes formed the Lakhmid and Ghassanid federations; the latter being a Sassanian vassal state, the former opposed to them. The Tayy, also of Yemenite origin later became Sassanian clients. Wars between Rome and Persia, with increased nomadic pressure leading to internecine fighting and depredation, weakened the buffer zone between Persia, Rome, and other nomads who in the 7th Century AD would sweep across Mesopotamia, Persia, into Central Asia, and forever change the world political and religious configuration.

#### LITERATURE CITED

- Adams, R. McC. 1965. Land behind Baghdad: a history of settlement on the Diyala Plain. University of Chicago Press, Chicago.
- Adams, R. McC. 1969. The study of ancient Mesopotamian settlement patterns and the problem of urban origins. *Sumer* 25:111-123.
- Babaev, A. and Magtimov, A. 1983. Landscape studies of Southern Turkmenia using remote sensing. *Problems of Desert Development* (3):57-64.
- Bonine, M.E. 1980. Yazd and its hinterland. 232p. Geographischer Instituts der Universitat Marburg, Marburg.
- Caskel, W. 1954. The bedouinization of Arabia. *American Anthropological Memoirs* 76:40.
- Dolukhanov, P.M. 1980. The ecological prerequisites for early farming in Southern Turkmenia. *Soviet Anthropology and Archaeology* XIX (3-4):359-385.
- Flannery, K.V. 1971. Origins and ecological effects of early domestication in Iran and the Near East. p.50-79 *In* Prehistoric agriculture, S. Struever editor. Natural History Press, New York.
- Frumkin, G. 1970. *Archaeology in Soviet Central Asia*. Leiden.
- Helbaek, H. 1963. Isin Larsin and Horian food remains at Tell Bazmosian in the Dokan Valley. *Sumer* XIX: 27-35.
- Helbaek, H. 1969. Plant collecting, dry farming, and irrigation agriculture in prehistoric Deh Luran. *In* Prehistory and human ecology of the Deh Luran Plain, F. Hole, K.V. Flannery, and J. Neely. *Memoirs of the Museum of Anthropology, University of Michigan*, Number 1. Ann Arbor.
- Hole, F., Flannery, K.V. and J. Neely. 1969. Prehistory and human ecology of the Deh Luran Plain. *Memoirs of the Museum of Anthropology, University of Michigan*, Number 1. 438p. Ann Arbor.
- Jacobsen, T. 1960. The waters of Ur. *Iraq* 22:174-185.
- Jacobsen, T. 1982. Salinity and irrigation: agriculture in antiquity. *Bibliotheca Mesopotamica* 14. 107p.
- Lisitsina, G.N. 1980. The history of irrigation agriculture in Southern Turkmenia. *Soviet Anthropology and Archaeology* XIX(3-4):350-358.
- Luckenbill, D.D. 1926. Ancient records of Assyria and Babylonia. Vol. II p. 160-163. University of Chicago Press, Chicago.
- Masson, V.M. and Sarianidi, I. 1972. *Central Asia, South Turkmenia before the Achaemenids*. London.
- Neely, J. 1974. Sassanian and early Islamic water control and irrigation systems on the Deh Luran Plain, Iran. *In* Irrigation's impact on society, T.E. Downing and M. Gibson editors. p.21-42. University of Arizona Press, Tucson.
- Nomani, F. 1976. Notes on the origins and development of extra-economic obligations of peasants in Iran, 300-1600 AD. *Iranian Studies*, IX(3-4):121-133.
- Nomani, F. 1977. Notes on the economic obligations of peasants in Iran, 300-1600 AD. *Iranian Studies* X(1-2):62-75.
- Oates, D. 1968. *Studies in the ancient history of Northern Iraq*. 176p. Oxford University Press. London.
- Oded, B. 1979. Mass deportations and deportees in the Neo-Assyrian Empire. 142p. Reichert, Wiesbaden.
- Safar, F. 1947. Sennacherib's project for supplying Erbil with water. *Sumer*, 3:23-25.
- Saggs, H.W. F. 1984. *The might that was Assyria*. 340p. Sidgwick and Jackson, London.
- Walters, S. 1970. *Water for Larsa*. Yale University Press, New Haven.
- Watson, A. 1983. *Agricultural innovation in the early Islamic world*. 260p. Cambridge University Press, Cambridge.
- Wenke, R.J. 1978. *Imperial investments and agricultural developments in Parthian and Sassanian Khuzestan, 150 BC to AD 640*. University Microfilms International, Ann Arbor. University of Michigan thesis, 1975.
- Wittfogel, K.A. 1971. Developmental aspects of hydraulic societies, pp557-571 *In* Prehistoric Agriculture, S. Struever editor. Natural History Press, New York.

# The Use of Riparian Vegetation in Damascus Basin<sup>1</sup>

Mohammad S. Abido<sup>2</sup>

---

Abstract.--The status of the riparian ecosystem and benefits obtained from it in Damascus, Syria, is described. Besides the natural functions of the riparian vegetation, it is a source of construction wood, fuelwood, fodder, food, and popular medicine. Other uses, such as recreation, fences and windbreaks, are also discussed. Clearing lands for agricultural purposes, water pollution, and urbanization are the main threats to the ecosystem. Proper disposal of waste and better management plans of the resource are essential to maintain and preserve the aesthetic and the practical value of this resource.

---

## INTRODUCTION

Damascus, the capital of the Syrian Arab Republic, is a city in the middle of a desert. It is a city whose history extends over 3000 years. Damascus is surrounded by lush vegetation, flowers, and an ample number of willow and poplar trees. In 1978, the population of the city is estimated to be around 1,142,000.

The secret of the thriving history of the city is the Barada River and its surrounding riparian vegetation. In fact, the importance of the riparian vegetation can be seen from the many names which were given to the city: "the inspiration of the poets," "the eye of the East," and "the rival of paradise" are a few examples of those descriptions.

The city has a semi-arid Mediterranean climate, characterized by a wet season - mainly in winter and a relatively long dry summer. Damascus receives about 190 mm of rainfall, mainly in the winter.

Primarily, the riparian vegetation dictates the landscape and the structure of the city and its suburbs. Buildings in Damascus city and in the villages outside are clustered along the river system, from its origin almost to its end.

## THE BARADA RIVER ECOSYSTEM

The Barada River is perennial, about 66 km

long. The river originates in an area of high mountains, which receives a high amount of precipitation in winter in the form of snow and rainfall. The river moves along a bed of bare rocks, eroding the rocks to form narrow canyons northwest of Damascus. The resulting sediments are deposited in fans southeast of Damascus. The latter area is generally known as AL-Goutha Basin.

The average discharge of the river is  $2.5\text{m}^3/\text{sec}$ , with a maximum discharge of  $25\text{m}^3/\text{sec}$  in May and a minimum of  $5\text{m}^3/\text{sec}$  in October. The catchment area is about  $262\text{km}^2$  (Khouri and Rasoul Agha, 1977).

The Barada River, is dammed by earthen structures in several locations along its course. Before entering the city, it is divided into seven small channels. Each channel is directed to different areas of the city, and given the name of that area. Those divisions were recognized a thousand years ago.

Throughout history, human beings altered the natural flow of water in the river and, subsequently, the dynamics of the riparian community. It is assumed that AL-Goutha Basin was an impenetrable jungle, with a wide variety of plants and wildlife. Today, the whole basin is composed of a mixture of various kinds of landscape, including buildings, paved streets, and a "man-made riparian vegetation."

## Land Ownership

Most of the land adjoining the Barada River is privately owned property. The owners, usually small farmers, build houses and other facilities on relatively high ground and raise crops and livestock on the low parts of the flood plains. Farmers believe that they have the right to use an unlimited amount of river water. In each village along the river, farmers have an agreement among themselves on how and when to use the water for irrigation and

---

<sup>1</sup>Paper presented at the Riparian Ecosystems and their Management: Reconciling Conflicting Uses Conference. Tucson, Arizona, April 16-18, 1985.

<sup>2</sup>Mohammad S. Abido is an Instructor of Forest Science, College of Agriculture, University of Damascus, Damascus, Syria.

and other purposes. In fact, such agreements have never been challenged by the government.

#### Species Composition

Since the natural vegetation of the area has developed under the influence of man and his activities, at the present time, much of the area looks like agricultural fields. Various trees, such as willow (Salix alba or Salix nigra) and plane (Plantanus orientalis), are found in abundance immediately along the river bank. Poplar (Populus nigra var hamoui or Populus alba var roumi) is found naturally and raised on man-made plantations on the flood plains. Associations of shrubby vegetation, such as roses (Rosa damascena), blackberries (Rubus idaeus), basil (Myrtus communis), oleander (Nereium oleander), common reeds (Phragmites australis), jasmines (Jasminus sp.), exist on various locations in the valley. Several varieties of ferns (Dryopteris sp.), mints (Mentha sp.), and grasses are present too.

The severe aridity of the environment, which precludes any farming outside the river flood plains, forces the farmers to clear the natural vegetation on the flood plain and convert the area into orchards and agricultural fields. Walnut (Juglans regia), apple (Malus sylvestris), apricot (Prunus armeniaca), pear (Pirus communis), plum (Prunus domestica), and pomegranate (Punica granatum), in addition to various types of vegetables and forage crops, are the most commonly grown in the valley.

#### USES OF RIPARIAN VEGETATION

Besides the natural functions of the riparian vegetation in stabilizing river banks, trapping silt and sediments, and providing habitat for fish, wildlife species, and birds, it plays an important role in the life of people, especially in an arid setting. It is a source of the following:

##### Wood Products

Small poles for construction are usually obtained from trees scattered along the river banks or from commercial plantations in the flood plains. After trees are cut, logs are sold at the site to local villagers for use in home construction. Usually, poplar wood is used in roofing and framework construction.

Since it is a fast growing tree species, poplar is widely grown in huge commercial plantations in the valley. It requires less tending and yields a large profit in a relatively short period of time. These intensively managed properties are private holdings.

Poplar wood and wood obtained from "minor" species, are sawed into lumber (in small private mills) to be used in the furniture industry and other light industries. Plane and poplar are mainly used in making doors, windows, shelves, tables, and cabinets. Because it is easy to nail and staple, low-quality (fluffy and knotty) poplar

and willow wood is used to make light packaging containers, crates, and boxes.

Recently, poplar has been grown primarily as a source of industrial timber for matches, chipboard, and pulp and paper along major rivers in the country. Also, the government has built a number of wood-based light industries, such as pencil and match plants, utilizing wood products obtained mainly from poplar plantations on the valley.

Craftsmen use poplar and willow wood for making wooden toys, jewelry boxes, and wooden shoes. Agricultural tools are made primarily from ash and poplar trees. Multi-stemmed species, wood residue, bark, and small limbs are used for firewood, and for cooking and heating.

##### Food

Some plants which grow along the river's banks are edible and have great nutritional value. Common fennel (Foeniculum vulgare) is cooked with food. Mint (Mentha viridis) is used, either fresh or dried, as a kind of spice. After harvesting and drying, it is ground and added to various foods, such as salad, and is also used in hot tea to give the drink its distinctive flavor.

Sumac powder, which is extracted after drying sumac fruits, forms a major component of certain recipes. Jelly and jams are usually made from berries by boiling them with sugar.

##### Popular Medicine and Other Commodities

Plants which grow along streams or in flood plains, in particular, the mint family, are used traditionally in popular medicine. The Arab philosopher and physician Ibn Sina wrote that balsam rejoices the heart and gives spiritual strength. Today, this old idea is still current. Common balsam (Melissa officinalis) is used as a remedy for sea sickness, headache, and for fainting fits. Also, the infusion of that plant is used as a remedy for scorpion and spider stings as well as for the relief of stomach pain.

Many uses of such plants have been recognized over the years. Pomegranate, for example, has a number of uses. The bark is used to cure dysentery and diarrhoea. Its fruits are edible and a syrup can be made from them. Even the skin of the fruits is used in dyeing cloth. Oleander and basil leaf extracts are used primarily to heal skin diseases such as scabies (Sarcoptes scabiei). Also, laurel leaves (Laurus nobilis) are added to laundry water to give clothes a distinctive scent and to soften them.

Soap is often made of laurel leaves. Oily materials are extracted by boiling the leaves in water for three days. When the oil is extracted, it is converted to soap by mixing it with another synthetic material.

##### Fences and Windbreaks

When an area in the flood plains is cleared for agricultural purposes, the existing vegetation is



left on the perimeter of the property. The uncut vegetation, primarily spiny shrubs, poplar and willow trees, serves two purposes: it acts as a live physical barrier to stray livestock, and it functions as a windbreak shielding the crops from wind damage. Also, poplar trees are planted inside the field along the irrigation ditches and as a divider between sections of the field.

#### Fodder

Land, such as marshes and meadows, which is not used for agricultural purposes is used primarily for goat, sheep, and cow grazing. Fodder crops, such as alfalfa and clover, are interplanted between fruit and poplar trees. Poplar and willow leaves, in addition to the leaves of other shrubby species, are used as a supplementary diet for livestock.

#### Recreation

One of the most important uses of the riparian ecosystem in arid and semi-arid environment of the Barada River is recreation. In desert cities, such as Damascus, where the temperature reaches 40°C, and hot winds sear the skin, the only place which provides shade and humidity is the riparian ecosystem, where water is available.

Camping and picnicking sites are scattered along the stretch of the river from Al-Baramike to Alhama, and even extend into Al-Zabadani Valley. During the weekend and vacation periods, people get out to those areas seeking shade and the scenic beauty of the valley.

Recreational water activities are carried in the reservoir from which the river originates. Large restaurants, cafes, and entertainment centers have been developed along the shores of the reservoir to attract tourists.

#### THREATS TO RIPARIAN ECOSYSTEM

Clearing riparian zones for agricultural land is a common practice. Horticultural and agricultural crops are scattered across the flood plains. Apple, pear, apricot, and walnut orchards and maize, wheat, and alfalfa fields are substituted for willows, vines, reeds, and many other species.

Pesticides and the destruction of natural vegetation destroy the habitat of many wildlife species. Some wildlife species are now considered to be in danger of extinction. Black bird, the Syrian woodpecker (Dendrocopos syriacus), and the jay (Garrulus glandarius) are a few examples.

Uncontrolled grazing of domesticated animals in the riparian zones hamper the regeneration of naturally occurring plant species due to excessive grazing and trampling.

Water pollution is a widespread problem in the river basin. In fact, it constitutes a threat to all the components of the ecosystem. The Barada, once "the river of gold," has become a system to carry sewer water and liquid wastes, especially during the dry season of the year. The main source of pollution is agricultural and industrial waste. Farm drainage water, and marble and cement plants discharge their wastes into the river. It is estimated that the amount of waste water discharged into the river is 4-5m<sup>3</sup>/sec.

Urbanization and highway developments are weakening the system more and more. Industrial and residential projects have been build in the flood plains due to the absence of zoning law.

Riparian vegetation in an arid or semi-arid environment is a very valuable biotic system. It is a source of wood, food, fodder, and other commodities. Rational and moral considerations require the maintenance and the preservation of the aesthetic and the practical value of the system. Reconciliation among the conflicting uses must be worked out by careful planning and assessing the needs and demands for each use. Finally, residential, industrial, and agricultural waste must be disposed properly away from the river to get the most benefits from this existing resource.

#### LITERATURE CITED

- Khoury, J. and W. Rasoul Agha. 1977. Ground Water in Syrian Arab Republic. Damascus, Arab Center for the Studies of Arid Zones and Dry Lands.

# Land Use in the Majjia Valley, Niger, West Africa<sup>1</sup>

Peter F. Ffolliott and Roy L. Jemison<sup>2</sup>

---

Abstract.--A reforestation project in the Majjia Valley, Niger, was undertaken to improve the microclimate, to reduce water and wind erosion, and to produce fuelwood. Windbreaks were planted, woodlots were established, and trees were distributed to the inhabitants. The windbreaks were effective in reducing wind velocities and, at times, retained soil moisture. Water consumption by vegetation in the windbreaks did not affect soil moisture in the agricultural crop rooting zone. Although fuelwood has not been harvested, agricultural crop yields in the windbreaks were higher than those in a control.

---

## INTRODUCTION

The Republic of Niger is a country in which two-thirds of the area lies in the Sahara Desert, and the remaining one-third is a semi-arid strip of land known as the Sahel. It is in the Sahel that the majority of people live as sedentary farmers. The plight of these farmers, along with the many nomads in the region, was brought to the attention of the world in 1970-74, when the Sahel was struck by drought. A lack of water and fodder, attributed to the drought, resulted in a loss of approximately 50 percent of the livestock, and forced many people to migrate in search of relief.

The Majjia Valley is one of the more important river basins in the Sahelian region of Niger. However, it is also considered highly populated for a rural area in West Africa, with nearly 50 people per square kilometer. Intense land use pressures, the most noted being farming, livestock grazing, and wood gathering, have resulted in severe degradation by water and wind erosion and a decrease in available soil moisture and fertility. In 1974, CARE, in collaboration with the Government of Niger, initiated a reforestation project, including the planting of windbreaks. The success of the 3,000 hectares in windbreaks to date is, perhaps, one of the best examples of good riparian zone management in West Africa.

## THE MAJJIA VALLEY

The Majjia Valley is situated in the arrondissements (counties) of Bouza and Birni'n Konni, Department of Tahoua, in southwestern Niger. The Majjia Valley extends, more-or-less northeast to southwest, covering approximately 25,000 hectares of predominantly agricultural land. The general altitude of the valley is between 300 and 600 meters.

### Physiography

The Majjia Valley consists of a plateau, deeply intersected by wide valleys, which are often temporarily inundated. The edges of the plateau form escarpments, on which boulder pavements are found. Extensive slopes and gentle outwash slopes connect the escarpments with the valley floor.

Due to a diversity of geologic materials and soil-forming factors, a variety of soils have developed in the Majjia (Bognetteau-Verlinden 1980). Many of these soils are characterized by relatively high fertility, a situation that is exceptional to this region of Africa. Soils derived from schist or limestone materials are particularly fertile. Alluvial deposits, with very sandy soils in the river beds, occur in the valley itself.

### Vegetation

According to the Yangambi classification, the Majjia Valley lies in the tree savanna zone of West Africa (FAO 1975, as cited by Bognetteau-Verlinden 1980). Among the more important woody species in the tree savanna of the Majjia are *Combretum* spp., *Guiera senegalensis*, *Acacia* spp., *Bauhinia reticulata*, *Anogeissus leiocarpus*, *Ziziphus mauritica*, *Poupartia birrea*, and *Ficus gnaphalocarpa*. However, due to the population pressures and subsequent

---

<sup>1</sup>Paper presented at the North American Riparian Conference on Riparian Ecosystems and Their Management: Reconciling Conflicting Uses. [Tucson, Arizona, April 16-18, 1985].

<sup>2</sup>Peter F. Ffolliott is Professor of Watershed Management and Roy L. Jemison is Research Assistant, School of Renewable Natural Resources, College of Agriculture, University of Arizona, Tucson, Arizona 85721.

demands for fuelwood, agricultural land, and grazing land, very little of the natural vegetation remains.

Today, only a few scattered trees protect the landscape from severe water and wind erosion. As a result, agricultural crop and livestock forage productivity has greatly declined, due in large part to decreased soil fertility and reduced soil moisture retention capacity.

#### Climate

Located in the Southern Sahel Zone of Niger, but in the central part of the "true Sahel," the climate of the Majjia Valley is characterized by two clearly distinguishable seasons: a rainy season of 4 months (June through September), and a dry season of 8 months (October through May). Most of the rain, which averages less than 500 millimeters a year, falls during intense thunderstorms, causing severe water erosion. Rainfall maximums occur in August.

The mean annual temperature is approximately 28°C, with a minimum mean monthly temperature of 25°C in January and a maximum mean monthly temperature of nearly 35°C in May. Relative humidities are low, particularly in the dry season when values are less than 20 percent. It has been estimated that potential evaporation exceeds 3 meters a year (Bognetteau-Verlinden 1980).

Niger is located in that part of West Africa affected by the northeastern trade winds and the southwestern monsoon, the latter being a carrier of rain. Hot, dry winds of relatively high velocities often carry large amounts of dust, especially during the dry winter months (November through April). With little vegetative cover, the erosive power of these winds is significant.

#### People

The population of the Majjia consists, for the most part, of Haussa farmers, who live in villages along the valley floor. On the lower slopes, villages of the Bouzou people, sedentary cattle-breeders, are found. Also, some Fulani, who are essentially semi-sedentary nomads, live in the area. As mentioned above, the population density in the Majjia Valley, including the lower slopes, is over 50 inhabitants per square kilometer and is increasing.

During the dry season, a large portion of the younger male Haussa population leaves the Majjia for seasonal work. However, a large portion of the population remains on-site throughout the year, surviving as best they can until the rains arrive.

#### Land Use

The Majjia Valley, including the temporarily inundated area, is an important agricultural area. Important crops are millet, sorghum, and niebe, the latter being a protein-rich bean that is

intercropped with millet (Bognetteau-Verlinden 1980). Cotton and some peanuts are grown as cash crops during the rainy season. The need for productive agricultural land is so great that almost no fallow land is found. Although the soils are relatively fertile to start with, the continued use of traditional farming methods (involving the application of no artificial fertilizer and only a limited amount of manure from the grazing animals) is resulting in decreased productivity.

In the dry season, village gardening is undertaken on areas where groundwater is available. Tomatoes, lettuce, and tobacco are grown for local consumption; onions are produced, mostly as a cash crop.

Many of the lands in the Majjia are used for extensive grazing of cattle, sheep, and goats, as well as donkeys, camels, and horses. Grazing of domestic livestock is also allowed on agricultural lands during the dry season (Bognetteau-Verlinden 1980). In general, the level of grazing in the Majjia Valley is too intensive for the carrying capacity of the land.

All of the land belongs to the central government, but traditionally, the inhabitants are responsible for the free distribution of agricultural land among the villagers. Once obtained, the rights to work the land are heritable, although the land can be leased or sold with the village chief as a witness.

Through a reforestation project, the forestry service in Niger is attempting to reclaim as much land as possible to improve the microclimate of the area, to protect the area against water and wind erosion, and to produce needed fuelwood supplies. The reclamation activities include planting of windbreaks, establishing village woodlots, distributing trees (free of charge) for live fencing, and creating small private woodlots and planting shade trees. Concurrently, the forestry service is attempting to protect the remaining natural vegetation through educational work and protective activities. More details of the "Majjia Valley Reforestation Project" are presented below.

#### Erosion

Water and wind erosion in the Majjia Valley is severe. In fact, this area is one of the most threatened in West Africa, with an estimated soil loss of over 2,000 tons per square kilometer a year (Delwaille 1973, as cited by Bognetteau-Verlinden 1980). This high erosion rate is easily understood through a review of prevailing climatic patterns and land use practices in the area.

As mentioned above, the Majjia is characterized by a rainy season with intense storms, a prolonged dry season with continuous winds in a direction parallel to the valley, and physiographic features that cause low permeability and high runoff. At the same time, a high population is exerting pressures on the land, causing a general deterioration of the vegetative cover and, therefore, a high susceptibility to water and wind erosion.

In large part, it was because of the severe water and wind erosion problems, along with an attempt to stabilize the livelihood of the rural families, that the "Majjia Valley Reforestation Project" was initiated.

#### MAJJIA VALLEY REFORESTATION PROJECT

In 1974, the forestry service in Niger and CARE entered into an agreement to undertake a forestry project to counter the severe effects of water and wind erosion and declining agricultural productivity. Originally funded by CARE, the project has also received support from the U.S. Agency for International Development (USAID), through a matching grant (Bognetteau-Verlinden 1980). The project area encompasses about 6,000 hectares of the Majjia Valley, approximately one-half of which is currently protected by windbreaks.

The "Majjia Valley Reforestation Project" actually began in 1975, with the planting of 13 kilometers of windbreaks in double rows of neem (*Azadirachta indica*) trees, planted 4 meters apart. Today, ten years later, the main activity of the project remains the planting of windbreaks; over 400 kilometers, along parallel corridors, have been planted. Other components of the project include free distribution of tree seedlings, riverbank protection, and the establishment of village and private woodlots.

#### Goals of the Project

In essence, the two major goals of the "Majjia Valley Reforestation Project" are to:

1. stabilize, and if possible, increase the agricultural income of rural families in the Majjia through tree planting activities, and protect agricultural lands from erosion and crops from the detrimental influences of desiccating winds; and
2. improve the ecological balance of the area, stimulate conservation efforts, and improve the environmental situation through protection of endangered natural resources by providing tree seedlings for planting on agricultural lands, in village and private woodlots, and in private compounds.

#### Tree Nurseries

A key to the success of the "Majjia Valley Reforestation Project" is the operation of nurseries which, upon request, supply the necessary planting stock for the project activities. Until 1983, two nurseries produced 30,000 tree seedlings a year. Recently, a third nursery was opened, located about midway between the original nurseries (Bognetteau-Verlinden 1980). The current production level of this third nursery is 15,000

plants a year, although it will expand in the future.

Seeds are collected from locally grown trees, planted in polythene bags, and grown in the nursery for a period of 4 to 7 months. In addition to neem, limited numbers of *Acacia seyal*, *Acacia scorpioides*, and *Prosopis juliflora* seedlings are produced.

#### Planting Methods

For the windbreaks, the lines of trees were planted in holes (40 x 40 centimeters wide, 60 centimeters deep) dug by the villagers. In the initial years of the project, the trees were planted in a 4 x 4 meter rectangular spacing pattern. Subsequently, a 4 x 4 meter triangular spacing was adopted (Bognetteau-Verlinden 1980). The trees were planted by the nursery workers, again with the assistance of the villagers, after the first or second heavy rain of the season, usually in July. Following planting, no additional watering of the trees was done.

Planting of the village woodlots was done by the forestry service, in a 3 x 3 meter spacing. Land required for these plantations was selected by the forestry service, in consultation with the inhabitants.

For the other components of the reforestation project, trees were freely distributed to or collected by the villagers, during the rainy season. In general, the villagers cared for the tree plantings themselves, with advice from the forestry service.

#### Protection and Maintenance

During the initial two or three years after planting, the trees were protected against grazing by domestic livestock and bush fires. For the windbreaks, this protection was achieved by guardians, who removed the grazing animals (Bognetteau-Verlinden 1980). The guardians were frequently assisted by the farmers in the wet season. This system worked fairly well, and enclosure of the windbreaks was not needed. After three years, the trees were large enough to resist the browsing of livestock.

Farmers, who previously did not need to clean their fields because the weeds and crop residues were eaten by the livestock, found it necessary to clean their fields by prescribed burning. However, close control of the fires was requisite to avoid damaging the young trees.

The village woodlots were fenced with chicken wire for the initial few years of establishment. After this, the commonly planted *Prosopis juliflora* formed live fencing, which provided sufficient protection for the growing trees.

The distributed trees were protected against grazing by livestock with traditional means of

individual protection, including thorny branches, millet stalks or grass mats, woven branches, and poles with chicken wire.

During the initial two years of establishment, the windbreak lines were cleared to avoid competition of weeds. This clearing was carried out by the farmers and guardians during the rainy season; as the agricultural fields extended, in general into the windbreak lines, the farmers simply applied the same weeding techniques here as in their fields (Bognetteau-Verlinden 1980).

The village woodlots were maintained by the forestry service and the farmers, primarily through the cutting down of weeds in the initial two years after planting. The freely distributed trees were maintained (weeding and, if necessary, pruning) by the individual villagers.

#### Harvesting

Through 1984, harvesting of wood products has not taken place in the windbreaks or in the other kinds of plantations created by components of the reforestation project. However, based on the results of an intensive evaluation of the "Majjia Valley Reforestation Project," which is currently underway, it is conceivable that limited harvesting may be prescribed in the future.

#### PRELIMINARY EVALUATION

Quite possibly, the most important component of the reforestation project is the system of windbreak plantings. Therefore, a preliminary evaluation of the windbreak system was undertaken in 1979-80 to determine the influence of the windbreaks on:

1. reducing wind velocities;
2. increasing available soil moisture for plant growth; and
3. increasing agricultural crop yields.

Details of the measurement techniques employed in the preliminary evaluation have been outlined in the evaluation report and, therefore, will not be described in this paper (Bognetteau-Verlinden 1980). Instead, a brief summary of the major conclusions is presented in the following paragraphs.

Wind velocities inside the windbreak system, measured at 1 meter above the ground, were decreased to approximately 45 to 80 percent of the "free" wind velocity. This height was considered high enough to disregard the surface roughness factors, but low enough to indicate the erosive force of the winds. The maximum reduction in the wind velocities occurred at 5-H to the leeward of the windbreaks, a distance of 5 times the average height of the trees in the windbreaks.

Wind velocities at 2.5 meters above the ground, a height selected to represent the

theoretical height of the millet crop, were reduced to between 40 and 70 percent of the "free" wind velocity. At this height, the maximum reduction in wind velocities was recorded at 1-H to the leeward of the windbreaks.

In general, wind erosion was greatly reduced by the windbreak system, although direct measurement was not made. From on-site observations, it appeared that the overall effectiveness of the windbreak system in reducing wind velocities, and consequently, wind erosion could be improved by creating a higher density of vegetation near the ground in the lines of windbreaks.

Available soil moisture in the windbreak system was greater than that on an adjacent "control" during periods of high water supply. With a low water supply, available soil moisture in the windbreaks was less than that on the "control," although better plant growth was observed in the windbreak system. Water consumption by the vegetation in the windbreaks did not seem to affect the amount of available soil moisture in the most important rooting zone of the millet crop.

Agricultural crop yields, primarily millet, inside the windbreak system were nearly 130 percent of those on the "control," ranging from 150 percent at a distance of 5-H leeward to the windbreaks at 110 percent at a distance of 16-H. Of course, no millet production was possible underneath the neem trees once the canopy was closed. Nevertheless, correcting for the loss in production underneath the trees, overall production of the millet reached 125 percent of that measured on the "control" site.

The results of this preliminary evaluation were encouraging. However, it was recommended that, before definitive conclusions on the impacts of windbreaks are drawn, and before widespread replications of the "Majjia Valley Reforestation Program" can be promoted, more detailed research and subsequent evaluation are required. Therefore, an intensive evaluation study, jointly undertaken by CARE and USAID, was formulated in 1984 (CARE 1984).

A principle "benefit" of this detailed evaluation study will be a better understanding of the interactions among people, trees, and agricultural crop production under a windbreak system, an important agroforestry system. Additionally, it will serve to assist the Government of Niger in more effectively utilizing those resources that are designed for reforestation interventions. It should also help to broaden the base of reliable information needed by developmental planners in the West African Sahel.

#### SUMMARY

When a drought in 1970-74 caused a 50 percent loss of the livestock and forced migration of the sedentary farmers in the Majjia Valley, a reforestation project was undertaken by the forestry service in Niger, in conjunction with CARE and USAID. The objectives were to improve the microclimate of

the area, to protect against water and wind erosion, and to produce fuelwood. To accomplish these, windbreaks were planted, village and private woodlots were established, and trees were distributed (at no charge) to the inhabitants to plant for live fencing and to provide shade. Newly established nurseries grew seedlings (from locally collected seeds) for the plantings.

Although no harvesting of fuelwood has taken place, the windbreaks proved to be effective. Wind velocities were reduced significantly at both 1 meter and 2.5 meters (the theoretical height of millet) above the ground, with maximum wind reduction 5-H and 1-H, respectively, to the leeward sides of the windbreaks. It was speculated that higher density vegetation near the ground would be more effective in reducing wind erosion.

Available soil moisture was greater in the windbreak than on the control when water supplies were high, however, the opposite was found when water supplies were low. Water consumption by vegetation in the windbreaks did not affect available soil moisture in the important rooting zone

of the millet. Additionally, agricultural crop yields were 125 percent of those in the control.

Before this reforestation project can be replicated in other riparian zones in the Sahelian region, more research and evaluation are necessary to better understand the interactions among people, trees, and agricultural crops in windbreak systems.

#### LITERATURE CITED

- Bognetteau-Verlinden, Els. 1980. Study on impact of windbreaks in Majjia Valley, Niger. CARE, 81 p., Niamey, Niger.
- CARE. 1984. Proposal for an evaluation study of CARE's Majjia Valley Windbreak Project. CARE, 55 p., New York, New York.
- Delwaulle, J. C. 1973. Resultats de six ans d'observations sur l'erosion au Niger. Bois et Forets des Tropiques, No. 150, 132 p.
- FAO. 1975. Methods de plantation forestiere dans les savanes Africaines. FAO Collection: Mise en Valeur des Forets, 113 p., Rome, Italy.

# Rio Yaqui Watershed, Northwestern Mexico: Use and Management<sup>1</sup>

Luis Bojorquez<sup>2</sup>, Raymundo Aguirre<sup>3</sup> and Alfredo Ortega<sup>4</sup>

---

Abstract.-- This paper describes the uses and community types of the Rio Yaqui Watershed in Sonora Mexico. The management problems are interrelated but there are no studies of sufficient regional scope to integrate the uses of the area. To cope with this, research activities associated with management have to be multidisciplinary.

---

## INTRODUCTION

The State of Sonora, Mexico, is located on the northwestern corner of The Mexican Republic. It is limited by the Sierra Madre Occidental, on the east, by the State of Arizona on the north, by the state of Sinaloa, on the south, and by the Gulf of California, on the east.

Sonora presents two main landforms:

Northwestern Coastal Plain. - It extends from the outlet of the Colorado River to the south along the coast, and

Sierra Madre Occidental. - It is adjacent and parallel to the coastal plain. It is the longest and most continuous mountain chain of Mexico ranging from the eastern border of Sonora and Arizona to central Mexico. The maximum altitudes in its Sonoran range are of more than 2,800 m above sea level (a. s. l) (DETENAL 1982a).

The Sierra Madre Occidental has a large influence on the hydrology of the area since is the zone of recharge of the Northwestern Coastal Plain (DETENAL 1981a) where the most important developments are located. Rio Yaqui is the principal river of Sonora. It originates in the Sierra Madre Occidental and discharges into the Gulf of California.

The use of an ecosystems often influences other natural systems (Ffolliott 1980). Riparian ecosystems utilization impact, and is impacted by, other uses of their basin. For this reason a study was made to describe the vegetational community types that occur in the Rio Yaqui Watershed and their sometimes conflicting usage.

Agriculture, ranching, mining, forestry, and recreation are the principal land uses at present (SAHOP 1980) and larger impacts and conflicts can be expected in the future. Basic research is needed to reconcile apparently antagonistic requirements of individual components of some multipurpose combinations (King 1980).

## DESCRIPTION OF THE WATERSHED

### General Characteristics

Rio Yaqui Watershed occupies an area of approximately 73,000 km<sup>2</sup> (30% of the state). It originates in the west aspect of the Sierra Madre Occidental and is adjacent to the Rio Sonora Watershed in its west limit. The north limit lies in Arizona, U. S. A., approximately 40 km north-east of Douglas. The direction of the long axis is northeast from the outlet. Though the area includes two states, 95% of the basin is in Sonora (SARH 1979).

The complex drainage pattern in the mountains is gradually reduced when the Yaqui approaches to the coastal plain (DETENAL 1981a), where several arroyos join the main flow. The principal river of the watershed is the Yaqui, which has a mean annual runoff of about 2.9 billion m<sup>3</sup> (SARH 1979) The principal tributaries are the Bavispe, the Moctezuma, and the Sahuaripa. The Bavispe drains in to La Angostura Reservoir and continues running south, forming the Yaqui at the junction with the Sahuaripa river. The Moctezuma

---

<sup>1</sup>Paper presented at the Riparian Ecosystems Management Conference. University of Arizona, Tucson, Az. April 16-18, 1985.

<sup>2</sup>Luis A. Bojorquez-Tapia is Graduate Student of Watershed Management, University of Arizona, Tucson, Az.

<sup>3</sup>Raymundo Aguirre-deluna is Graduate Research Assistant Range Management Department, University of Arizona, Tucson Az.

<sup>4</sup>Alfredo Ortega-Rubio is Researcher in Instituto de Ecologia, A. C. Mexico, D. F.

flows southward on the western limit of the basin and is connected to the Yaqui by the Plutarco Elias Calles Dam, better known as El Novillo. From here, the Yaqui runs out southward to the Alvaro Obregon Reservoir, which supplies water for the irrigation of 2,250 km<sup>2</sup> of agricultural land. Fourteen drains deliver the water used by agriculture to Tobarí Bay (Bojorquez 1983).

Ciudad Obregon, Agua Prieta, and Nacozeri are the most important cities in the watershed.

#### Climate

The anticyclonic high pressure system gives to Sonora its arid and semi-arid characteristics. The general trend is a gradient of aridity from the coast to higher elevations. Thus, for the watershed: mean annual precipitation is about 559.8 mm, from which 92.0% is lost by evapotranspiration, 0.4% infiltrates, and 7.6% leaves as runoff (DETENAL 1983b). Total annual precipitation ranges from 100-200 mm around the outlet to 1,000-1,200 mm in the Sierra Madre (DETENAL 1981c). Mean annual temperature ranges from 24-26°C in areas close to the ocean to 6-8°C in the highest elevations (DETENAL 1981d).

However, the rugged topography in the mountains causes combinations of climate types within this gradient (Rzedowski 1978). According to the classification by Koeppen, the Northwestern Coastal Plain has subdivisions of climate types BS and Bw while the Sierra Madre Occidental has subdivisions of climates BS and Cw (DETENAL 1981a).

### VEGETATIONAL COMMUNITIES

The variety of microenvironmental conditions in the watershed causes a high overlapping of communities distributions. On the other hand, present knowledge of the vegetation in Mexico does not allow comparisons between community types in great detail (Rzedowski 1978). In the present paper, the classification by DETENAL (1981a) was followed. The watershed presents the following vegetational types:

#### Forest

##### Bosque de Pino

The pine forest includes the following species distributed in the Sierra Madre Occidental between 1500 and 3000 m a. s. l.: Pinus reflexa, P. arizonica, P. lumholtzi, P. ayacahuite, and P. ponderosa. Microhabitats are important for the predominance of a particular species, by example, P. reflexa is dominant on the

most xeric aspects while P. ayacahuite prevails on more mesic slopes of canyons.

The similar ecological requirements of pines and oaks, their entangled successional relationships, and the diversity of microhabitats produce a mosaic of forest types hard to delineate (Rzedowski 1978). Oak forest components often can be found above the lower limit of the pine forest specially in xeric aspects so it is possible to recognize the following associations:

Bosque de Pino-Encino. - The pine-oak association is formed by the same species of the pine and oak forests but with dominance of pines. It is found in the lower, more xeric areas of the pine forest.

Bosque de Encino-Pino. - This community establishes in disturbed zones in both the pine and the pine-oak forests. Quercus and Pinus are the two main genera, but oak is more abundant. The following species are common: P. cembroides, Q. arizonica, P. emoryi, Cupressus arizonica, and Juniperus deppeana.

Bosque de Encino. - Deciduous oaks dominate between 1000 and 2000 m a. s. l. in slopes and plateaus. The most abundant species is Q. chihuahuensis, although is displaced locally by Q. tuberculata and Q. albocincta in more mesic habitats. Other important species are: Q. fulva, Q. sipuraca, Q. santaclarensis, Q. hypoleuca, and Q. duranguensis. Bunchy grasses are also important.

##### Selva Baja Caducifolia

This deciduous forest is typical of subhumid hot climates. The majority of the individuals (75%-100%) lose their leaves for long periods (6-8 months). The dominant trees lack of spines and the highest are 15 m tall. It is widely distributed on hillsides with good drainage between 300 to 1200 m a. s. l. Common genera of this community are Ceiba, Bursera, Conzattia, Ipomea, Lysiloma, and Ficus.

##### Bosque de Galeria

The riparian forest exists in areas where soil moisture is sufficiently high to support a different community from the drier surroundings (Johnson and Carothers 1982). Populus, Platanus, and Taxodium are the most widely distributed along perennial streams upland. Prosopis and Acacia are present in arroyos (Rzedowski 1978).

#### Scrub

##### Matorral Desertico Microfilo

This desert scrub vegetation type is composed of shrubs with small leaves or



folioles. Found on alluvial soils at elevations from sea level to 800 m a.s.l., it can be divided in:

Matorral Subinerme. - Thorny plants (30%) and plants without spines (70%) form this vegetational type. Important species are: Fouquieria splendens, Yucca sp., Condalia sp., Mimosa sp., and Prosopis glandulosa.

Matorral Espinoso. - The proportion of thorny shrubs in this community is higher than 70%. Prosopis spp., Acacia spp., Condalia spp., Atriplex spp., and Fouquieria spp. are common.

#### Matorral Subtropical

The subtropical scrub is typical in areas of ecological transition between relatively humid conditions and more xeric scrubs. The majority of the plants lose their leaves for long periods. This community is denser with clearings occupied by grasses in places of high human activity.

The principal species are: Ipomea spp., Bursera spp., Eysenhardtia polistachia, Acacia pennulata, Forestiera spp., Mimosa spp., Opuntia spp., Lysiloma spp., and Mirtillocactus geometrizans.

#### Matorral Sarcocaula

The Arid Tropical Scrub is found on rocky, shallow soils close to the coast. Characteristic species are: Bursera hindsiana, Bursera microphylla, Bursera odorata, Jatropha cinerea, Jatropha cuneata, Ambrosia dumosa, Cercidium floridum, Encelia farinosa, Fouquieria spp., Larrea tridentata, Olneya tesota, Opuntia cholla, Pachycereus pringlei, etc.

#### Mezquital

This community is characteristic of deep, alluvial soils or in areas with poor drainage. The principal species is Prosopis spp. (mezquite), but Olneya tesota and Cercidium spp. are also common.

#### Grassland

##### Pastizal Natural

This grassland community is determined by the interaction of local climate, soils, and biota. It is found in plateaus and valleys of moderately deep soils between 200 and 2300 m a.s.l. Important species are: Bouteloua spp., Bacharis spp., and Hilaria spp. In disturbed areas by fire, overgrazing, overcutting, or abandoned agricultural lands, Aristida spp. are common.

## USES OF THE COMMUNITY TYPES

### Forestry

Pine communities were not exploited at the level programmed for 1984 (SFF 1985). Pinus spp. were the most valuable trees in Sonora. Total volume obtained in 1984 was about 43,300 m<sup>3</sup>. Sawlogs was the main product, but others were cellulose, posts, and crossties. Populus spp. sawlogs were also obtained but on a much lower scale.

On the contrary, scrub communities were overexploited. The total for the state was 113,300 m<sup>3</sup> or 175% the programmed volume (SFF 1985). Fuelwood and charcoal were the principal products. Prosopis spp. and Olneya tesota were the most utilized for that purpose (SAHOP 1980).

Major problems of the forestry industry in Sonora are lack of product classification systems and modern technology, combined with a deficient enforcement of forestry policies.

### Agriculture

Agriculture is the most important activity in Sonora and accounts for more than 25% of the state's gross internal product (SARH 1979).

The Rio Yaqui contributes to the most important agricultural development in Sonora. The communities of Matorral Sarcocaula and Mezquital near the coast were replaced by 2,250 Km<sup>2</sup> of irrigated land. The main crops cultivated on the watershed in descending order of importance are: wheat, cotton, saffron, soy, corn, and sesame (SARH 1979).

The water supply is mainly from the river, but now groundwater irrigation is also common so aquifer overexploitation and marine water intrusion is a potential problem (SAHOP 1980).

Agriculture also pollutes water. Pesticides and fertilizers are discharged into the river causing a negative impact on estuarine systems and fisheries of Tobari Bay (Bojorquez 1983).

### Ranching

The livestock industry uses about 70% of the area of the watershed and is distributed in all the vegetational types.

Overgrazing is a serious problem. Proper carrying capacities are exceeded by 2 to 10 times, and a common sequence of deterioration seems to be evident. Palatable species have been replaced by undesirable ones, then, if pressure conti-

nues, all vegetation is removed and soil is eroded (SARH 1979).

In recent years poultry and hog industries have exceeded cattle raising in economical importance in the state. Impacts of these activities on the watershed have yet to be determined.

#### Mining

There are several mines in the watershed. Gold, silver, tungsten, zinc, coal, magnesium, and lead are the main products. Yet, copper mining is the one that has an economic impact in the nation. However, the side effects on the water and air quality are high.

The open pit mine of La Caridad, close to Nacoziari, and the smelter greatly contribute to the pollution problem that occurs in the river causing a definite impact on riparian ecosystems.

#### CONCLUSIONS

Riparian ecosystems have suffered heavy damage from the misuse of the natural resources in the Rio Yaqui Watershed.

Overgrazing in all community types and fuelwood obtainment in scrublands have devastated the vegetative cover in many areas. Then, erosion has taken its role reducing soil fertility and increasing sediment yield in rivers and reservoirs. Soil mass movement is decreasing water quality affecting riverine systems and other users downstream. Sediment in reservoirs have reached in 25 years the levels planned for 100 years, reducing their useful life and making water management more difficult.

Grazing also has impacted riparian forests directly. Recruitment of palatable species (specially *Populus*) has been reduced because livestock consumes their seedlings. Consequently this stands are becoming senescent gradually.

Cooper mining pollutes water with consequences yet to be determined. Unfortunately because of economics, water quality is not the main concern.

Agriculture is the final user of the river and, consequently, the most affected by negative impacts on water quality and quantity.

Demands for good and services are more intense than ever before so large impacts on the vegetational communities are expected in years to come. Therefore, problem oriented research is required to achieve a multi-purpose management of this watershed.

#### LITERATURE CITED

- Bojorquez T. L., G. de la Cruz y S. Gaona. 1983. Evaluacion de las alternativas de uso de la Isla Huiyulai y la Bahia Tobari. Reporte. Asesoría de asuntos ecologicos, Gobierno del Estado de Sonora. 63 p.
- DETENAL. 1981a. Carta de Climas, La Paz, Tijuana. Escala 1:1000000. Direccion General de Geografia del Territorio Nacional. Mexico, D.F.
- DETENAL. 1981b. Carta Hidrologica, Aguas Superficiales. La Paz, Tijuana. Escala 1:1000000. Direccion General de Geografia del Territorio Nacional. Mexico, D.F.
- DETENAL. 1981c. Carta de Precipitacion Total Annual. La Paz, Tijuana. Escala 1:1000000. Direccion General de Geografia del Territorio Nacional. Mexico, D.F.
- DETENAL. 1981d. Carta de Temperaturas Medias Anuales. La Paz, Tijuana. Escala 1:1000000. Direccion General de Geografia del Territorio Nacional. Mexico, D.F.
- Ffolliott, P.F. 1980. Integration of wildlife and other natural resources polices. 24-25 pp. In: Ffolliott, P.F., and G. Halffter (tech. coor.) Consequences of Natural Resources Polices with Special Emphasis on Biosphere Reserves. USDA Forest Service Gen. Tech. Rep. RM-88. Rocky Mountain Forest and Range Exp. Sta. Fort Collins, Co. 57 p.
- Johnson, R.R. and S.W. Carothers. 1982. Riparian habitat & recreation: inter-relationships and impacts in the Southwest and Rocky Mountain Region. Eisenhower Consortium Bulletin 12, 31 p. Rocky Mountain Forest and Range Exp. Sta., Forest Service, USDA, Fort Collins, Colo.
- King, K.F. 1980. Multiple- Use research. 3-9 pp. In: IUFRO/MAB Conference Research on Multiple Use of Forest Resources. USDA Forest Service Gen. Tech. Rep. WO-25. 167 p.
- Rzedowski, J. 1978. Vegetacion en Mexico. Ed. Limusa. Mexico, D.F. 432 p.
- SAHOP 1980. Ecoplan del Estado de Sonora. Report. Gobierno del Estado de Sonora. 255 p.
- SARH 1979. Prontuario Estadistico Sonora Agropecuario. Departamento de divulgacion y relaciones publicas. Gobierno del Estado de Sonora. 168 p.

# Effects of Dryland Farming on Navajo Riparian Lands<sup>1</sup>

Jo Ann B. Jayne<sup>2</sup>

---

Abstract.--The Navajo people have recognized that dryland farming caused accelerated erosion, depletion of vegetation and water shortages in their riparian zones. Water and land resource development policies and programs are currently being implemented to protect agricultural lands.

---

## INTRODUCTION

The Navajo Tribe is on the threshold of the most extensive riparian ecosystem management planning period it has ever experienced. Comprehensive studies made by tribal agencies on the water resources of the Navajo Reservation has clearly revealed the critical nature of Navajo water and land resources problems.

The Navajo government administration has moved to enact and implement into Navajo tribal law a water code containing new policies, standards, and procedures for rivers, streams, and lakes. The new policies are designed to ensure proper use and preservation of land and water resources to protect the health, welfare, and economic security of the citizens of the Navajo Reservation. These new policies were formulated and adopted by their governing body, the Navajo Tribal Council, in 1984.

In support of these management efforts, budgets of the departments within the agencies responsible for water resources planning have been increased significantly.

Thus the stage has been set for a large scale endeavor to translate into action the programs required to develop and manage water and land resources to assure an adequate, regulated supply of quality water not only for flood control or irrigation, but also for previously more neglected purposes such as community water supply, fish and wildlife, outdoor recreation, and the enhancement and protection of traditional religious practices.

Traditional dry farming techniques used by the Navajo and their impact on the riparian zones are discussed in this paper.

---

<sup>1</sup>Paper presented at the North American Riparian Conference (University of Arizona, Tucson, April, 16-18, 1985).

<sup>2</sup>Graduate student in Forestry-Watershed Management at the University of Arizona, Tucson.

## DESCRIPTION OF AREA

### The People

The Navajo population is at 160,000 with about 12,000 participating in subsistence dry-land farming. It is estimated that 10,000 acres are located within the major riparian zones.

Water is a vital element in Navajo life. It is used sacredly in religious rites. The clan system is highly associated with water properties. The Navajo origin belief is that rivers and streams are the blood of the land as blood is to their bodies.

### Location and Topography

The Navajo Reservation, comprising an area of about 25,884 square miles, or 16,565,537 acres, is located in the United States in northeastern Arizona, northwestern New Mexico, and the southeastern corner of Utah and is roughly the size of West Virginia.

This area has within its borders a wide diversity of topography, climate, soils, vegetation and geologic materials. It lies within the Colorado Plateau physiographic province and has topography typical of this province (Fenneman 1931). In general, it is characterized by a rough and broken terrain, including steep mountainous areas, plateaus, and mesas intermingled with steep canyon walls, escarpments, and narrow valley bottoms. The plateau and mesa tops are usually gently to strongly sloping while the sides are commonly steep to very steep. The valley bottoms and alluvial slopes adjacent to the intermittent drainages are dominantly gently sloping. Moderately steep and rolling upland ridges and low hills are interspersed with the more common landforms.

The altitude within the reservation ranges from 2800 feet in the southwestern part where the upper tributaries of the Little Colorado River leave the reservation to 10,000 feet on the highest mountain peak in the north.

Much of the country, however, has an altitude that ranges between 6,000 feet and 7,800 feet. Altitudes above 7,800 feet are mainly in the Navajo commercial forest which lies predominantly in the center of the reservation and constitutes approximately four percent of the land.

#### Climate

The reservation generally has a semi-arid continental climate with mean annual precipitation ranging from six inches in the southwestern plains to twenty-five inches in the mountain ranges along the Arizona-New Mexico border (BIA 1981).

More than forty percent of the annual precipitation falls in July through September, mostly from heavy thunderstorms. During the summer most moisture comes from the Gulf of Mexico, entering the reservation from the southeast in the general air circulation about the Bermuda high pressure area which is displaced westward (BIA 1981).

The main source of moisture in winter is Pacific Ocean storms moving eastward in the zonal circulation. Average annual snowfall ranges from less than two feet in drier sections to more than six feet in the areas of greatest precipitation. The season of most snowfall is November through April.

Mean annual temperatures range mostly from 48 to 52 degrees Fahrenheit. Extremes of temperature have been over 100° F. and -20° to -30° F. in the winter (BIA 1981). May through October are the warmest month of the year.

#### Soils and Vegetation

Altitude - 4,500 feet to 6,000 feet

The soils and climate in these areas contribute to a grassland and mixed shrubland plant community. At upper elevational ranges are pinyon-juniper woodlands characterized by Rocky Mountain juniper (Juniperus scopulorum), Utah juniper (Juniperus osteosperma), rabbitbrush (Chrysothamnus nauseosus), greasewood (Sarcobatus vermiculatus), and snakeweed (Gutierrezia microcephala). The grass dominated lands occur on the deeper soils on relatively level to gently rolling terrain. They are characterized by red three-awn (Aristida longiseta), blue grama (Bouteloua cracilis), and galleta (Hilaria jamesii). Generally the soils are derived from alluvial deposits and aeolian sources and are commonly deep, light in texture, and reddish-brown. Rock outcrops and badlands are prominent features in some areas.

Altitude - 6,000 feet to 7,800 feet

These areas are dominated by soils over shale and sandstone and/or by soils in residuum and alluvium from sandstone and redbeds. They are commonly deep to moderately deep, light in

texture, and light or reddish-brown in color.

The soils will support a pinyon-oak association in the higher elevations interspersed with big sagebrush (Artemisia tridentata). Big sagebrush is often an understory of the pinyon-juniper. Associated shrubs and grasses are Stansbury cliffrose (Cowania mexicana) and crested wheatgrass (Agropyron desertorum). Lower elevations are characterized by scattered pinyon-juniper, extensive areas of big sagebrush, galleta, and Indian rice grass (Oryzopsis hymenoides).

Altitude - 7,800 feet to 10,000 feet

These areas are dominated by soils over sandstone and are deep to shallow, loamy, dark-colored, and with some rock outcrops. The highest elevations are characterized by Engelmann spruce (Picea engelmannii), alpine fir (Abies lasiocarpa), white fir (Abies concolor) with outcrops of quaking aspen (Populus tremuloides). The intermediate and lower elevations supports stands of ponderosa pine (Pinus ponderosa var. scopulorum) with Colorado blue spruce (Picea pungens), wavyleaf oak (Quercus undulata), and pinyon pine (Pinus edulis). Grasses include mountain muhly (Muhlenbergia montana), Arizona fescue (Festuca arizonica), and galleta.

#### TRADITIONAL USES OF RIPARIAN ZONES

The Navajo economy in the early 1900's was a simple arrangement of subsistence exploitation of the geographical landscape, and exchange of goods, either for other goods or for money and credit. All of the exploitative and many exchange activities were directly connected with the use of the land.

#### Subsistence Dryland Farming

Farming Practices.--Corn, hay, beans, potatoes, peaches, wheat, vegetables, and melons constituted the principal non-commercial, agricultural products in 1940. Corn brought in 39 percent of the \$450,100 income generated for that year (BIA 1941).

Fields were small and often irregular and were often outlined by uncleared trees, gullies, or cliffs.

Preparation of ground for planting began at the end of April and plowing and planting lasted through early June. Planting was done at the time of plowing, without any intervening ground preparation. It was often accompanied by various rites and ritual procedures. Straight furrows were plowed without regard to contour. Manure or other fertilizers were seldom used, nor were fields ever intentionally followed. Insects, early frosts, and torrential rainfalls sometimes killed or washed out whole fields of new seedlings and made replanting necessary.

During the busy times of plowing, planting, cultivating, and harvesting, the cooperation among the various kin groups was intensive. Even so, crops were frequently planted late and yields were cut by early fall frosts. Total acres planted in

1941 was 32,201 acres with 29,840 harvested that year (BIA 1941).

Field Location and Water Sources.--Field location was dependent upon water sources from 1) rainfall, 2) groundwater, or 3) floodwater from surface flooding of ephemeral streams.

Fields dependent upon rainfall were located in these areas:

A. On high alluvial plateaus with deep drainage lines. Soils are shallow, residual sandy loam derived from sandstone and shale.

B. On thin aeolian soils over lava beds. Soils are shallow, clay loam derived from basalt.

Fields primarily watered by surface runoff or by ground water moisture were located in these areas:

A. On flood plains or flat stream terraces of larger valleys.

B. On bottoms of small, deep, sandy canyons.

C. Near upper ends of canyons or valleys, or on colluvial and alluvial outwash slopes.

#### EFFECTS OF DRYLAND FARMING

An accelerated erosion cycle beginning shortly after the practice of dryland farming caused a shift of land holdings. Many farms once advantageously located for water became useless and were abandoned because of gullying and trenching. This was especially true in the regions where floodwater irrigation was practiced. Fields formerly supplied by floodwater had become dependent on rainfall. Farmers were gradually forced by terrain changes and landownership problems toward cultivation of fields farther away from the riparian zones.

Navajo impact on riparian zones essentially began with the development of dryland farming. Trees and other vegetation were removed for agriculture and houses. Diversion of water from streams and rivers created water shortages. Erosion was accelerated as vegetative cover was removed.

The Navajo people have recognized that soil erosion from early dryland farming has caused, in part, the damages of down-stream areas. These areas lie idle today.

#### CONCLUSION

The history of water resource planning on the Navajo Reservation is dominated by periodic adoption to the demands for use of water by its growing population and increasing economic activity.

There was early recognition of the multiple-use possibilities of water projects and of the interrelationship of the water and land resources within stream and river basins by the local people. In spite of the intensive thought and effort given to this subject and the encouraging developments in the past few years, the Navajo Tribe still lacks a fully coordinated policy and a definite, sound program for riparian ecosystem planning of its streams and rivers.

In contrast to past case by case project authorizations, the Navajo has now developed a water code. With its prospective on the pressing water needs of the next few decades, this code can augment desirability for action and reiterate the need for comprehensive water resources development.

The stage for progress has been set further by the accumulated weight of: 1) water policy regulation, 2) improvement of standards and techniques for formulation and evaluation, and 3) experiments in interagency planning.

However, water and land resources will always be threatened regardless of ownership and laws. Each segment of the Navajo population has an important stake in the proper development of water resources.

It has not yet been clearly defined either in general policy statements nor in actual experience how comprehensive water resources development plans should be implemented and sustained on the Navajo Reservation. However, water resource development programs on the Navajo Reservation should maximize their contribution to economic growth and represent efficient low cost means of obtaining the products or services they provide.

#### LITERATURE CITED

- Fenneman, N.M. 1931. Physiography of the Western United States. McGraw-Hill Book Company, New York.
- U.S. Department of Interior, Bureau of Indian Affairs. 1941. Statistical summary, human dependency survey, Navajo Reservation. 1940. 108 p.
- U.S. Department of Interior, Bureau of Indian Affairs. 1981. Navajo Water Resources Evaluation. Volume II, Part I. p. 1-2.

# Role of Riparian Vegetation in Pakistan<sup>1</sup>

Bashir H. Shah<sup>2</sup> and John L. Thames<sup>3</sup>

---

Abstract.--Pakistan is poor in forest resources, and exploits all possible sources of wood to fulfill its needs for fuel, timber and other wood products. Riparian species are a major source of wood in many parts of the country, particularly in the province of Sind. The important riparian species in the country are Acacia arabica, Dalbergia sissoo, Tamarix spp., Salix sp., Morus alba, Populus euphratica and other Populus species.

---

## INTRODUCTION

At the time of independence from British rule and the separation from India in 1947, Pakistan was apportioned only a small area of productive forest land. Whatever was available, was over-exploited to meet the immediate and heavy demands created by the influx of refugees and the growing needs of development. The forest lands which fell to Pakistan were mostly confined to the northern hilly portion of the country with some irrigated plantations and riverine forests in the south.

The total area of the country classified as forest land and administered by the Forest Department has now been increased to the extent of about 4.3 million hectares, almost 5 percent of the total land area of the country. The increase is partly due to avenue plantings along roads, canals, and railway lines and to the establishment of irrigated plantations in barrage zones. Major additions were made by the appropriation of unclassified and privately owned lands. However, less than one half of the national forest area is classified as productive.

The present forest lands are not sufficient to meet national and local demands for wood and other forest products. The deficiency must be fulfilled from private farm forests and by imports. The remainder of the national forest area is

classified as protective forest lands. Some of this area is in steep topography in the more humid, northern part of the country, but the greater portion is in the arid, semi arid provinces in the central and southern parts of the country. These dryland forests are primarily composed of Prosopis, Acacia, Ziziphus, and Capparis tree species and various shrubs. These trees and shrubs have no commercial value but are exploited for fuelwood and fodder by local people (Sheikh 1977).

Of the total national forest area, about 7 percent is in the inundation plain of the Indus river (Amjad 1982). Most of these riverine forests are located in Sind province in the south and are the major source of wood products for the province. In a country poor in forest resources all possible sources of wood are exploited. Riparian vegetation is an important source of wood not only in fulfilling national needs but also in fulfilling the needs of local populations. The purpose of this paper is to review the role played by riparian vegetation, primarily that along the Indus river, in meeting these needs.

## THE INDUS

The Indus is the principal river in Pakistan. It originates in the Himalayan Ranges within India and enters Pakistan from the northeast. Passing through the Himalayans it receives the Kabul river at Attock, and after passing through the Salt Ranges to the south of the Himalayans it enters the arid Indus plain at Kalabagh. The major tributary rivers, Jehlum, Chenab, Ravi and Sutlej, also originate in the Himalayans and join at Punjnud near Multan. In addition to small tributaries, the Indus also receives the Kurrum and Gomal rivers from the west from Kalabagh. The

---

<sup>1</sup>Paper presented at the North American Riparian Conference [University of Arizona, Tucson, April 17-18, 1985].

<sup>2</sup>Bashir H. Shah is Research Assistant, University of Arizona, Tucson, Arizona.

<sup>3</sup>John L. Thames is Professor of Watershed Management, University of Arizona, Tucson, Arizona.

The river flows 1250 km southward through the Indus plain and enters the Arabian sea near Karachi.

In the northern part of the Indus plain between Kalabagh and Punjab the river has incised a narrow flood plain 24 km wide and 450 km long. The western edge of the flood plain is adjacent to a high, alluvial plateau and the eastern edge is bounded by the sandy Thal desert. Within these confines, the river continuously changes its path and divides and subdivides into branches, which reunite to form a braided system. The new alluvial plains so developed are invaded by pioneer plant species followed by several stages of plant succession which reaches a typical climax riverine forest with the passage of time. Eventually these forest areas are eroded and engulfed by the river. Sediment is deposited on the opposite side forming huge side bars which result in the formation of new fluvial plains. The formation of fluvial plains by erosion and deposition is a regular feature of the Indus. Because the river is confined by the high lands on both sides of the flood-plain, the area is inundated annually during the monsoon season of July and August.

Below Punjab, the river enters the southern flood plain in Sind Province where the topography is flat. Due to the annual deposition of large sediment loads, the level of the riverbed and the areas immediately adjacent have been slowly raised above the surrounding plain. The results in the past were annual floods which caused heavy loss of life, property and agricultural crops.

About 100 years ago levies were constructed on both sides of the river roughly 24 km apart for a distance of 800 km to contain the river during the flood season. This has created a condition in the southern flood plain very similar to that of the northern portion and with similar plant communities.

This 24 km by 1250 km flood plain was the main source of food, fodder and wood for local populations for many years. The moisture retained by the clayey alluvial soil from the receding flood water was sufficient to mature winter crops of wheat, grain, lentils, peas and oil seeds. The same agricultural practices continue today. However, the greater portion of food production is from irrigated agriculture. Extensive irrigation works of reservoirs, diversions, and canals have now been constructed along the river. Rainfall varies from about 250 mm in the northern portion of the plain to 150 mm in the southern portion.

#### THE RIVERINE FORESTS OF THE INDUS

The principal species of the southern flood plain are Acacia arabica, Prosopis spicigera, Populus euphratica, Tamarix articulata, Tamarix dioica and Salvadora sp. In many areas these trees may form a fairly complete canopy 12-15 m high in which Acacia arabica usually predominates with varying amounts of Prosopis spicigera. Populus euphratica is usually present in the drier areas.

Plant succession in the flood plain begins with the pioneer species, elephant grass (Typha elephantina). This is an aquatic plant that invades newly deposited but permanently submerged alluvium. It commonly grows in the water near the banks of shallow streambeds. As sediment from successive floods is trapped by the grass, the alluvium is raised to a level where flooding only occurs during the monsoon season. At this stage, elephant grass is replaced by Saccharum spontaneum, a tall grass which reaches a height of 2 m. If deposition continues the site is invaded by dense thickets of Tamarix dioica. This shrub species has single stems, which are seldom greater than 3 cm in diameter, and grows to a uniform height of about 2 m. Successive sediment deposits may build the alluvium to a level where internal drainage will allow tree growth. The site may then be occupied by the climax species Acacia arabica, Eucalyptus euphratica and Tamarix articulata. Prosopis spicigera and the shrub like tree, Salvadora sp, may occupy the margins between the riverine forest and the subtropical thorn forest. If tree species do not invade the site, or are removed, the tall grass, Saccharum munja, will dominate the site.

The riparian vegetation of the northern flood plain has a composition similar to that of the southern plain but with the absence of Acacia arabica. This tree is not frost hardy and is supplanted by Dalbergia sissoo, an introduced species that withstands cold temperatures. This tree is valued for fuel and timber and is planted in irrigated plantations.

#### USES AND MANAGEMENT OF RIVERINE SPECIES

The riparian vegetation of the Indus and its tributaries helps in stabilizing river banks and providing habitat for wildlife. However, nearly every component of the community has value in fulfilling some human need, and ingenious uses of the materials provided by each of the riparian species have developed over the centuries.

#### Principal Species

Acacia arabica is the principal commercial tree and the dominant species in the southern riverine forest. The management system used with the species involves clear cutting on a 20 year cycle followed by broadcast seeding toward the end of the monsoon season when the river is receding. This is a fast growing multipurpose tree used for the production of timber, fuel and other wood products and is the main source of mine props for the country. The bark is used for tannin and the gum is collected for a variety of uses. It is a very good browse species and the foliage is also used during the dry season as fodder for camels and goats. The animals, particularly goats, prefer the pods and help both in the dissemination of seeds and in their germination. Large herds of goats are encouraged in the area partly for this purpose. The seeds have hard coats that otherwise must be treated with acid or boiling water if used in artificial regeneration.

Dalbergia sissoo is the principal commercial species in the northern riverine forests. The tree reseeds naturally but is also planted extensively. Seedlings are grown in the nursery for one year where they attain a height of about one meter. The stem is then pruned off about 2 cm above the root crown, and the root-shoot is used for outplanting. Plantings are made on the edges of excavated, boot shaped pits at spacings of 4.6 m. The pits are about 10 meters long, a foot or so wide and one foot deep. Their purpose is to retain water and to assist in natural regeneration by root suckers. The plant sites are irrigated by hand at the time of outplanting. Once the species has been established on an area, regeneration by root suckers and coppicing sustains the stand. Thinnings for fuelwood are made at intervals of 6 years up to 30 years and at 10 year intervals thereafter up to 60 years. The final cut is made at age 60 to produce fine cabinet wood and wood for ornamental objects.

#### Minor Species

Populus euphratica is a fast growing species which provides fuelwood and supplies the wood used in lac work, turneries and for handicraft cottage industries.

Tamarix articulata is also fast growing and occupies moist sites. It is a good browse species and supplies wood for fuel, agricultural implements and also for handicraft cottage industries.

Prosopis spicigera is slow growing and occupies dry sites in the transition zone between the riverine and thorn forests. It is a preferred source of fuelwood and timber and is a good source of fodder for camels, goats and sheep.

Tamarix dioica is a scrub species favored for basket making. It is also a good browse species and is used for fuel.

#### Grass Species

Saccharum munja is a good grass for cattle when in the early growing stage. When mature it produces stems 3-4 meters long which are used as thatching material for roofs of houses and sheds in the villages. The stems are also used for making baskets, woven stools and chairs, and were the main material used for making writing pens which are still used by primary school children in villages.

Saccharum spontaneum provides good forage both in the early growing stages and at maturity when the grass is about 2 meters tall, it is harvested and stored for livestock fodder for the winter. The grass is also used as short fiber material in the paper pulp industry. About 4,852,000 kg are harvested annually for this industry.

Typha elephantina is prized for its soft, fluffy leaves which are 2 to 3 cm broad and more than a meter long. Because of their softness, the leaves are used throughout Pakistan on sleeping cot beds. The fibers are also used for mats, baskets and strings for cots.

#### Riparian Vegetation of the Indus Tributary System

In addition to these typical Indus riverine forests, plants grow on the banks of tributary rivers and stream channels in the northern hill tract and western mountain ranges. The riparian vegetation of the tributaries plays an important role equal to that of the Indus in providing wood and other products for local populations. The main species are Dalbergia sissoo, Morus alba, willow, Populus ciliata, Populus euroamericana in addition to Tamarix and grasses.

The wood from mulberry and willow support the sporting goods industry, and Populus euroamericana is used in the match industry. The branches of both mulberry and willow are also used in basket making. The sericulture cottage industry depends upon the leaves of mulberry.

#### CONCLUSION

Riparian vegetation is the main source of wood and wood products in one of the four provinces of the country. It produces wood for furniture, timber, mining props, cottage industry, sporting goods and the match and pulp industry. In addition to wood and wood products riparian plant communities provide forage for livestock, fiber for ropes, cordages, strings, material for baskets and mats, tanning material and gum. In addition, riparian vegetation helps in stabilizing river banks and provides habitat for many wild birds and animals.

In a country poor in wood resources where the people collect leaves, straw and cow dung for fuel, riparian vegetation proves God's gift in fulfilling their needs for fuel, timber to construct their shelters, material for their beddings, fodder to feed their animals and a source of earnings.

#### LITERATURE CITED

- Amjad, M. and I. Mohammad. 1982. State of Forestry in Pakistan. Special Publi. Forest Economics Branch, Pakistan Institute, Peshawar.
- Sheikh, M. I. and M. Hafeez. 1977. Forest and Forestry in Pakistan. Pakistan Forest Institute, Special Publication.



# Annual Phenological Profiles of Plants in and Adjacent to Two Riparian Habitats in Southeastern Arizona<sup>1</sup>

Karen R. Adams<sup>2</sup>

---

**Abstract.** During a 12-month study, observations were made and data collected on a suite of plants growing near a fresh water stream and in a cienega in SE Arizona at 5000-6000'. The dates of flowering and fruiting and periods of leaf growth and stem elongation were recorded for trees, shrubs, herbaceous perennials and annuals growing in both water-logged and well-drained soils. Phenological profiles can provide insight into (a) animal use of wetlands, (b) the timing of reproductive events of closely related species and (c) the role local factors may play in certain phenological responses.

---

## INTRODUCTION

Detailed studies on the timing of flowering, fruiting and periods of active plant growth versus dormancy are rare in Southwestern botanical literature, although one study encompassing a number of desert plants exists (Humphrey 1975). In the present project, reproductive and vegetative status was monitored for a number of plants over a 12-month period in two riparian habitats in the Huachuca mountain region of southeastern Arizona.

## PROCEDURES

After visiting and evaluating 12 riparian sites, two were selected because of their high diversity of native flora and minimum impact from historic forces, particularly domestic animal grazing. Canelo Hills Cienega<sup>3</sup> is located west northwest of the Huachuca Mts. along a tributary stream to the San Pedro River; it is maintained by two permanent underground springs (Hendrickson and Minckley 1984). A freshwater stream in the Huachuca Mts. that often dries up in May and June drains steep-walled Ramsey Canyon<sup>4</sup> into the San

Pedro River Valley south of the present town of Sierra Vista. Both locations have been under the care of the Arizona Chapter of the Nature Conservancy, since 1969 (Canelo Hills) and 1975 (Ramsey Canyon) respectively.

These two riparian sites were visited 12 times each over a period from June 1983-June 1984, with the frequency of visitation dependent on the general level of plant activity. During each visit a series of observations were made on all plants examined previously and on new ones collected then. Characteristics monitored were based on the condition of an entire population whenever possible, and included: (1) leaves (none present; buds present; actively growing; mature), (2) stems (no active growth; active growth), (3) flowers (none; buds present; in full flower; withering) and (4) fruit/seeds (none; immature; mature; ripe fruit from previous calendar year present). Herbarium voucher specimens have been verified at the University of Arizona Herbarium, and nomenclature follows two standard taxonomic works (Kearney and Peebles 1960 and Gould 1951).

## RESULTS

A phenological profile covering a single year is currently under preparation for over 100 plants from the two locations; included are trees, shrubs, perennial herbs, grasses and annuals, from both water-logged soils and nearby upland sites. The list includes obligate and facultative riparian species as well as upland species; phenological data for facultative riparian species growing in an upland location could well vary from that collected here. Information on grasses and annuals requires additional field observations, however data on shrubs and perennial herbs is presented in Appendix I. For illustrative purposes, data on tree species from the two sites has been incorporated in

---

<sup>1</sup>Poster Session presented at the first North American Riparian Conference (Tucson, Arizona, April 16-18, 1985). Fieldwork supported by a Grant-in-Aid of Research from Sigma Xi, the Scientific Research Society.

<sup>2</sup>Karen R. Adams is a PhD student in Ecology and Evolutionary Biology, University of Arizona, Tucson, 85721.

<sup>3</sup>Donnell Canyon Arizona, Quadrangle, 7.5' Series; T21S, R18E, NW 1/4 of SW 1/4 of Sect. 33 and NE 1/4 of SE 1/4 of Sect. 32; 4925' elevation.

<sup>4</sup>Miller Peak Arizona, Quadrangle, 7.5' Series; T23S, R20E, SE 1/4 of SW 1/4 of Sect. 9; 5700-6000' elevation.

Table 1. Phenological profile of trees in or adjacent to two riparian habitats in southeastern Arizona. All trees are from Ramsey Canyon except for *Populus Ecemontii* and *Juglans major*, monitored in Canelo Hills Cienega.

	JAN	FEB	MAR	APR	MAY	JNE	JLY	AUG	SEP	OCT	NOV	DEC
<i>Abies concolor</i> (Gordon & Glendinning) Hoopes			fb	ff,*	fw				O	F,d	F	
<i>Acer grandidentatum</i> Nutt.			fb,*					F	F,O	F,d		
<i>Arbutus arizonica</i> (Gray) Sarg.	FP	FP	*		ff	ff			O	d		
<i>Eraxinus velutina</i> Torr.				*					O	d		
<i>Juglans major</i> (Torr.) Heller				*	ff	fw			F,O	F,d	F	
<i>Juniperus Deppeana</i> Steud.	FP	FP	FP,ff	FP,fw	FP,*				F,d	F	F	F
<i>Pinus cembroides</i> Zucc.				*					O	d		
<i>P. Engelmannii</i> Carr.			fb,*	fb				F	F,O	F,d	F	
<i>P. strobiformis</i> Engelm.					fb,*	ff	fw		F,d	F	F	
<i>Platanus Wrightii</i> Wats.			*					d				
<i>Populus Ecemontii</i> Wats.		fb,*	ff	F								
<i>Pseudotsuga Menziesii</i> (Mirbel) Franco var. <i>glauca</i>			ff	ff,*	fw				F,O	F,d	F	
<i>Quercus arizonica</i> Sarg.				fb,*	fw				O		F,d	F
<i>Q. hypoleucoides</i> Camus				*					F,O	d		
<i>Q. rugosa</i> Nee.			ff,*	fw				F	F,O	d		
<i>Robinia neomexicana</i> Gray				*	ff	ff,F	F	F	F	d		
<i>Salix Gooddingii</i> Ball	fb	fb	fb,*	ff	fw				O		d	
<i>S. lasiolepis</i> Benth.	fb	ff	fw,F,*					O		d		

fb = flower buds present; ff = in full flower; fw = flowers withered; \* = leaf emergence and/or stem elongation first observed; F = ripe fruit available on plant; FP = ripe fruit formed in a previous calendar year is available on plant; O = overwintering buds first observed; d = all outward signs of plant growth have ceased (dormant).

Table 1. This table reveals the wide variety of phenological patterning present in just one life form. For example:

1. Duration of ripe fruit availability on trees ranges from approximately 1 month (*Salix* sp.) to 4 months (*Robinia*) to over 8 months (*Juniperus*).

2. No single oak (*Quercus*) species has ripe acorns clinging for more than 2 months, however the oaks present in Ramsey Canyon reveal sequential fruit ripening, providing an acorn resource in the habitat for a 5-month period from August through December. The different oak species were in full flower as much as 2 months apart.

3. While most trees have some mature fruit evident by November, *Arbutus* fruit does not appear ripe until January.

4. Willow (*Salix*) trees were the first to resume noticeable reproductive activity in January, 2 months or more before active vegetative growth was noted for most species. However, while floral bud initiation was synchronous for the 2 willows monitored, flowering and fruiting was not.

5. Gymnosperms (*Abies*, *Juniperus*, *Pinus*, *Pseudotsuga*) vary up to 2 months in their resumption of active stem elongation and needle emergence, and in floral bud initiation.

6. The formation of overwintering flower and/or vegetative buds seems nearly synchronous among all trees, occurring in September. This precedes a general cessation of all outward signs of plant growth by October, although a number of species retain clinging ripe fruit beyond that time.

DISCUSSION

The contribution phenological profiles can make to an understanding of Southwestern Natural History is significant. Although this study covers only a single annual period and should be repeated as well as expanded geographically, it provides some basic data helpful to wildlife biologists interested in animal use of wetlands. For example, the timing of available fruit varies widely among tree species, as does the length of the period ripe fruit can be found clinging to a tree. Animals able to utilize acorns could rely upon separate oak species that appear to ripen in sequential order.

These data might also provide insight into plant responses when phenological regimes are compared for closely related species. For example, both members of *Salix* initiate flower bud development simultaneously, yet flowering and fruiting periods are not synchronous. Perhaps one species requires a greater total heat accumulation in order to flower; alternatively, competition for insect pollinators could account for temporal segregation of peak flowering periods.

The 3 members of *Pinus* studied, as well as the 3 oaks (*Quercus*), also reveal diversity in timing of flowering within each genus; could such scheduling function to reduce the chances of hybridization? The influence of some local factor is suggested by simultaneously overwintering bud formation in trees, followed rapidly by cessation of noticeable plant activity.

LITERATURE CITED

Gould, Frank W. 1951. Grasses of Southwestern United States. Biological Science Bulletin No. 7, University of Arizona Press.  
 Hendrickson, Dean A. and W. L. Minckley. 1984. Cienegas-Vanishing Climax Communities of the American Southwest. Desert Plants 6(3).  
 Humphrey, Robert R. 1975. Phenology of selected Sonoran Desert Plants at Punta Cirio, Sonora, Mexico. Journal Ariz. Acad. of Science 10:50-67.  
 Kearney, Thomas H. and Robert H. Peebles. 1960. Arizona Flora. University of California Press, Berkeley.

APPENDIX I. Phenological data on shrubs and perennial herbs from two riparian habitats in southeastern Arizona. Observations made June '83-June '84.

SHRUBS	JAN	FEB	MAR	APR	MAY	JNE	JLY	AUG	SEP	OCT	NOV	DEC	1 2		
													RC	CH	
<i>Acalupha Lindheimeri</i> Muell. Arg.								ff	fw, F	F	d				X
<i>Amorpha fruticosa</i> L.				*	ff	ff	fw		F	F	F, d		X		
<i>Arctostaphylos pungens</i> H.B.K.	fb	ff	fw	*				F	F, fb	F, fb	d, fb	fb	X		
<i>Berberis Wilcoxii</i> Kearney	FP, fb	FP, fb	ff, *				F	F, d	F, O	F	F	F	X		
<i>Ceanothus Fendleri</i> Gray		fb	fb, *	ff	fw	F					d		X		
<i>Cercocarpus breviflorus</i> Gray				*		fb	ff		F		d		X		
<i>Fendlera runcinata</i> Gray				*	fb	FP	F, FP	F, FP	F, FP				X		
<i>Garrya Wrightii</i> Torr.			*			F					d		X		
<i>Rhamnus betulae-folia</i> Greene.				fb, *	fb	ff		F	F, d				X		
<i>R. californica</i> Esch.					fb	ff	fw		F	F					X
<i>Rhus trilobata</i> Nutt.						fb, *	fb	ff	fw, F, O	F, d			X		
<i>Rhus trilobata</i> Nutt.	FP				*	fb	ff	fw		F, d	F	F	X		
<i>Ribes aureum</i> Pursh.	*		ff	fw			F	F	F	F, O	d		X		
<i>Vitis arizonica</i> Engelm.			*	fb	fw			F	F, d	F	F		X		

## APPENDIX I. (continued)

PERENNIAL HERBS	JAN	FEB	MAR	APR	MAY	JNE	JLY	AUG	SEP	OCT	NOV	DEC	1 RC	2 CH
<i>Aralia racemosa</i> L.	x	x	x	x	x	x	Fb,*	FF	FF	d	x	x	X	
<i>Apocynum Suis-</i> <i>dorfii</i> Greene.	x	x	x	*	Fb	fb	FF	Fw,F		d	x	x		X
<i>Berlandiera</i> <i>lyrata</i> Benth.	x	x	x	x	FF,*	FF,F	FF,F	FF,F	Fw,F		d	x		X
<i>Carex chihuahuensis</i> <i>Mackenz.</i>	x	*	FF	FF	FF	Fw,F	F,d		x	x	x	x	X	
<i>C. lanuginosa</i> <i>Michx.</i>	x	x	x	FF,*	FF	Fw,F	F,d	F	F	x	x	x		X
<i>C. occidentalis</i> <i>Bailey.</i>	x	x	x	FF,*	FF	Fw,F	d							X
<i>Cucurbita</i> <i>foetidissima</i> <i>H.B.K.</i>	x	x	x	x	*			FF		F	d	x		X
<i>Eleocharis</i> <i>castellata</i> <i>Torr.</i>	x	x	x	FF,*	FF	FF	FF	Fw	F	d	x	x		X
<i>Epilobium</i> <i>californicum</i> <i>Hauskn.</i>	x	x	x	x	x	FF,*	FF	FF,F	FF,F	FF,F	d	x		X
<i>Equisetum hiemale</i> <i>L.</i>	x	x	x	Fb,*	Fb	fb	fb	FF,F	F	F	F	d	X	
<i>E. laevigatum</i> <i>A. Braun</i>	x	x	x	*	Fb	fb	fb	FF	F		d	x	X	
<i>E. laevigatum</i> <i>A. Braun</i>	x	x	x	*	Fb	fb	FF	FF,F	FF,F	FF,F	FF,F	d		X
<i>Euphorbia robusta</i> <i>(Engelm.) Small</i>	x	x	x	x	FF,*	FF	FF	FF,F	Fw,F	Fw,F	d	x	X	
<i>Juncus longistylis</i> <i>Torr.</i>	x	x	x	x	x	FF,*	F	F	d	x	x	x		X
<i>J. saximontanus</i> <i>A. Nels</i>	x	x	x	x	Fb,*	FF	FF,F	FF,F	Fw,F, F			x		X
<i>J. tenuis</i> Willd.	x	x	x	x	x	FF,*	F	F,d	x	x	x	x		X
<i>Lactuca</i> <i>graminifolia</i> <sup>4</sup> <i>Michx.</i>						FF,F	FF,F	FF,F	FF,F	FF,F			X	
<i>Mimulus guttatus</i> <i>DC.</i>	x	*				FF	FF	FF,F	F	d	x	x		X
<i>Oenothera rosea</i> <i>Ait.</i>	x	x	x	x	x	FF,*	FF	FF,F	d	x	x	x		X
<i>Oxalis pilosa</i> <i>Nutt.</i>		d	x	x	*			FF	FF,F	FF,F			X	
<i>Oxybaphus</i> <i>coccineus</i> Torr.	x	x	x	x	x	Fb,*	FF	FF,F	d	x	x	x		X
<i>Ranunculus hudson-</i> <i>charoides</i> Gray	*					FF	FF,F		d	x	x	x		X
<i>R. macranthus</i> <i>Scheele.</i>	*					FF	FF	FF,F	FF,F	FF,F	d	x		X
<i>Rudbeckia</i> <i>laciniata</i> L.	x	x	x	*		FF	FF	FF,F				x	X	
<i>Rumex violascens</i> <i>Rech.</i>						FF	Fw	F	F,d	x	*			X
<i>Scirpus acutus</i> <i>Muhl.</i>	x	x	*	Fb	FF	FF	FF	FF,F	d		x	x		X
<i>S. americanus</i> <i>Pers.</i>	x	x	x	x	x	FF,*	FF	Fw,F	d					X
<i>Sisyrinchium</i> <i>demissum</i> <i>Greene.</i>	x	x	x	FF,*	FF,F	FF,F	Fw,F	F	F,d	x	x	x		X
<i>Stachys coccinea</i> <i>Jacq.</i>	*,FP	FP						FF,F	FF,F	FF,F	F	F,d	X	
<i>Thalictrum</i> <i>Fendleri</i> Engelm.			*					FF,F	Fw,F	d			X	

1 = Ramsey Canyon; 2 = Canelo Hills Cienega; 3 = stems continued to elongate throughout the year, even during the normal dormant season for other plants (Nov.-Feb); 4 = plant never completely died back to ground level; Fb = flower buds present; ff = in full flower; fw = flowers withered; \* = leaf emergence and/or stem elongation first observed; F = ripe fruit available on plant; FP = ripe fruit formed in a previous calendar year is available on plant; O = overwintering buds first observed; d = all outward signs of plant growth have ceased (dormant); x = plant has died back to ground surface.

# Riparian Habitat Restoration and Beavers<sup>1</sup>

Larry L. Apple<sup>2</sup>

---

Abstract.--This study was partially designed to determine whether materials could be supplied to beavers in marginal habitats, with resulting habitat improvement. The study was expanded to determine if both beavers and materials could be successfully relocated to these areas. The results have been very promising as a means of stabilizing and improving degraded riparian habitats.

---

## INTRODUCTION

Riparian habitats are areas of immense value, whether they occur in the Everglades of southern Florida, or in the Great Divide Basin of south-central Wyoming. These areas become increasingly important in dry to arid climates, where typically they represent less than 1% of the total land surface. Coupled with the fact that riparian habitats are the most productive areas in terms of forage production, cover, and a more consistently available supply of water for wildlife and livestock, the importance of these areas becomes even more apparent.

Since settlement times, these areas have been subjected to more consistent and concentrated use (both human and livestock), and in many areas these habitats are being lost. It has been demonstrated in Oregon that riparian habitats can be significantly improved through natural riparian recovery processes, simply by resting the area from livestock use (Winegar 1977). It was felt that habitat recovery would commence naturally in southwestern Wyoming if the riparian areas could be rested as well. A study was initiated in 1981 to determine whether this recovery could be enhanced and accelerated using beavers rather than the traditional high-cost, high-technology methods.

## METHODS AND RESULTS

The idea of relocating beavers to suitable habitat had been successfully tried in the past (Grasse and Putnam 1955, Collier 1959). The current project had initially involved providing beavers in marginal habitat areas with materials to reinforce their dams. The project was then expanded to include relocating beavers to historic beaver habitat. The next logical step in this

project was to determine if it would be possible to successfully relocate beavers to historic, marginal habitat areas, and then provide the materials that the beavers would need to initiate habitat restoration.

Two study sites were selected, each exhibiting similar features. Both had had heavy winter livestock grazing use; both had only remnant willows present; both had rapidly deteriorating riparian habitats; and both had perennial water. The Carrant Creek study area was fenced, while the Sage Creek area was left unfenced. Nuisance beavers (those whose activities were causing problems such as flooding hay meadows or plugging road culverts) were live-trapped and relocated to Carrant Creek in 1981 and 1982. Beavers returned to Sage Creek on their own in 1981, so no attempt was made to relocate animals, until two beavers were live-trapped and placed there in 1983. In both study areas, aspen trees were provided to the beavers and were quickly accepted and eagerly used.

To dispel the generally held misconception that the aspen was being provided simply to feed the beavers, and to still provide a means to reinforce the dams, another approach, using artificial materials, was attempted. Old truck tires were placed on the dam, wired to each other and to the dam itself and staked to each bank. In other cases, net wire was used in the same fashion. In every case, the beavers continued to build into the artificial materials with naturally occurring sagebrush, willows, and mud.

Within two years after seven beavers had been relocated to the study area on Carrant Creek, three major dam complexes had been built within the fenced area. Stream flow energies were now being dissipated across the length of the dam, developing subirrigated meadow areas, rather than continuing to cut deeper into the former box-shaped, gully-cut channel. Unusually heavy runoff from snow melt in the spring of 1983 washed out most of the unreinforced dams, but not before several mud bars had been created behind the dams. By the end of the third year, full riparian recovery was underway in those areas with elevated water tables resulting from beaver activity. The habitat response on Sage

---

<sup>1</sup>Poster session paper presented at the Riparian Ecosystem Management Conference. (University of Arizona, Tucson, April 16-18, 1985).

<sup>2</sup>Larry L. Apple is a Wildlife Management Biologist, Bureau of Land Management, U.S. Department of the Interior, Rock Springs, Wyoming.

Creek was similar, but because the stream profile here was more radically U-shaped, recovery was somewhat slower. After the ponds behind the dams silted in, the beavers shifted their activities upstream and built new dams.

#### DISCUSSION AND RECOMMENDATIONS

The intent of the study is not to create habitat for the beaver. The intent has been, and continues to be to improve riparian and aquatic wildlife habitats, using the beaver as a management tool. Although this technique is not a cure-all, it does appear to be a promising method, applicable in many dry, cool-desert situations. The riparian habitats on the study portions of Carrant Creek and Sage Creek have improved significantly due to beaver activity. Coupled with rest from livestock grazing, which provided for accelerated willow regrowth, the system has become self-supporting in only three years.

The process, stated simply and briefly, is this: beaver activity typically reduces the ability of the stream to transport sediment by reducing the effective slope of the stream channel. A series of beaver complexes reduces the stream flow velocities, thereby reducing the erosion potential of the moving water. The carrying power of the water is reduced, leading to accelerated deposition rather than erosion. The elevated water table that results locally from the activity of the beaver, leads to an extended period of time into the growing season, when subsurface water is in storage along the banks of the stream, and available for vegetative development. The ultimate objective is to vegetatively stabilize the beaver dam and the soil that is deposited behind the dam, thereby reestablishing the riparian vegetative community.

If relocating beavers is anticipated, then a number of techniques might be worth considering. For best results, rest from grazing, to help achieve a more rapid vegetative recovery, is necessary, either with fencing or through a grazing management system. Because most dam-building activity does not begin until late summer or early fall, live-trapping and relocating of beavers, or providing aspen or other reinforcing materials should be done at this time. Providing aspen or other means of reinforcing beaver dams is also most effective when done at an already active beaver dam site.

When using aspen, place the trees on the bank near the active beaver dam, rather than in the water. Experience with beavers at these study sites indicates that they more readily accept and use aspen when it is placed on dry land. They also seem to accept artificial reinforcement, such as net wire or a layer of tires, and will continue to build naturally occurring materials into the structure of the dam. Fortunately, beavers are very adaptable animals.

An important feature of the study has been to determine the response of wildlife to the improved habitat conditions at the study locations. The bulk of the monitoring to date has been done at the Carrant Creek area. Bird transects, fish surveys, and wildlife observations indicate that the overall response to the improved habitat conditions resulting from beaver activity and rest from livestock grazing has been quite good. Avian species richness has increased by approximately 20%, marsh hawks and mallards are now nesting within the study area, deer are fawning and rearing young in the heavy riparian vegetation, and brown and rainbow trout have moved into the study area from Flaming Gorge Reservoir.

Probably the most serious threat to any wildlife population is the loss of its habitat. Healthy riparian and wetland habitats are crucial to the life cycles of a great diversity of wildlife and plant species. This is especially true in the arid western United States, where water is a very precious commodity. Improving or restoring riparian habitats is not an easy task. The use of beavers to help accomplish this end is not a panacea, and may not be applicable in all situations. However, a beaver management program designed to solve a specific habitat problem should be considered in any riparian habitat management strategy.

#### LITERATURE CITED

- Collier, E. 1959. Three against the wilderness. 349 p. E.P. Dutton, Inc., New York, N.Y.
- Grasse, J.E., and E.F. Putnam. 1950. Beaver management and ecology in Wyoming. 75 p. Bulletin No. 6, Wyoming Game and Fish Department, Cheyenne, Wyoming. Revised 1955.
- Winegar, H.H. 1977. Camp Creek channel fencing-plant, wildlife, soil, and water response. Rangeman's Journal 4(1):10-12.

# Riparian Ecosystems of Alaska<sup>1</sup>

Keith D. Bayha<sup>2</sup>

---

Abstract.--The wide array of climatic conditions found in the Nation's largest state is illustrated by the equally wide variety of riparian ecosystems. As elsewhere, Alaska's riparian habitat are vital to a large variety of fish and wildlife species. Economic exploitation of natural resources also threatens Alaska's riparian ecosystems.

---

Despite the fact that Alaska has far more riparian habitat than any other state (Brinson et al. 1961) there is almost no mention of this in the considerable literature on the subject. The Western Division of the American Fisheries Society did recognize Alaska in its position statement in 1980, but no details were presented.

The purpose of this paper is to increase awareness with Alaska's riparian habitats, their values, and the threats to them in the setting of this National Symposium.

## HOW MUCH RIPARIAN HABITAT DOES ALASKA HAVE?

I was asked this question by my colleagues who were preparing the U.S. Fish and Wildlife Service position paper for this Symposium. The answer is no one really knows because no systematic inventory has been completed. The National Wetlands Inventory (NWI) will eventually provide this information but so far only about 10% of Alaska has been mapped by this program. At the current rate of 2% per year, it will be in the mid-1990's before we have mapped the 35% of the State considered high priority.

Brinson et al. (1981) contains an estimate of 29,275,000 acres of riparian ecosystems for Alaska. This may be viewed as conservative. Our NWI biologists estimate that of the 76 million acres of Alaska in the National Wildlife Refuge System (about 20% of the Alaskan landmass) there are between 10 and 20 million acres of riparian habitat adjacent to the 58,000 miles of streams and 5 million acres of natural lakes. While it is true the National Refuge System has some of the choice wetland areas, by no means are all such areas

in the system. Our NWI staff estimates a more realistic estimate of riparian habitat would be from 30 to 50 million acres.

## WHAT ABOUT DIVERSITY OF RIPARIAN HABITATS IN ALASKA?

Because Alaska is so large, the climatic conditions vary considerably. The coastal rain forest of Southeast Alaska experiences relatively mild temperatures and precipitation of up to 200 inches per year, while the North Slope has desert-like precipitation patterns on a permanently frozen subsoil.

Perhaps the best way to answer this question is with photographs. Alaska is commonly subdivided into six regions: Interior, North Slope, West Coast, Alaska Peninsula and Aleutian Islands, Southcentral and Southeast (Fig. 1). A cluster of photographs illustrate the diversity of riparian ecosystems found in each of these regions (Figs. 2-32). One should not assume this small sample covers the full range of riparian habitats but it does show the diversity is indeed great.

## WHAT ARE THE FISH AND WILDLIFE VALUES OF ALASKA'S RIPARIAN HABITATS?

In Alaska, just like elsewhere, the rivers, lakes, and sea coasts receive the nutrient and energy flow of the landscape. The riparian lands are utilized by birds and mammals as they seek their share of this nutrient/energy base. Many species forage in the adjacent waters (Figs. 33-35) and use the riparian lands for cover (Figs. 36-38) and travel corridors (Fig. 39). Others forage in the riparian habitats on the vegetation (Figs. 40-42) and on other inhabitants (Figs. 43-45). Some seem to forage not at all until we biologists come along (Fig. 46). With respect to value to fish and wildlife, Alaskan riparian ecosystems are not all that much different from those documented elsewhere.

---

<sup>1</sup>Paper presented at the First North American Riparian Conference: Riparian Ecosystems and their Management -- Reconciling Conflicting Uses, April 16-18, 1985, Tucson, AZ.

<sup>2</sup>Deputy Assistant Regional Director/Habitat Resources, U.S. Fish and Wildlife Service, Anchorage, AK.

Figure 1. Climatically distinct regions of Alaska.

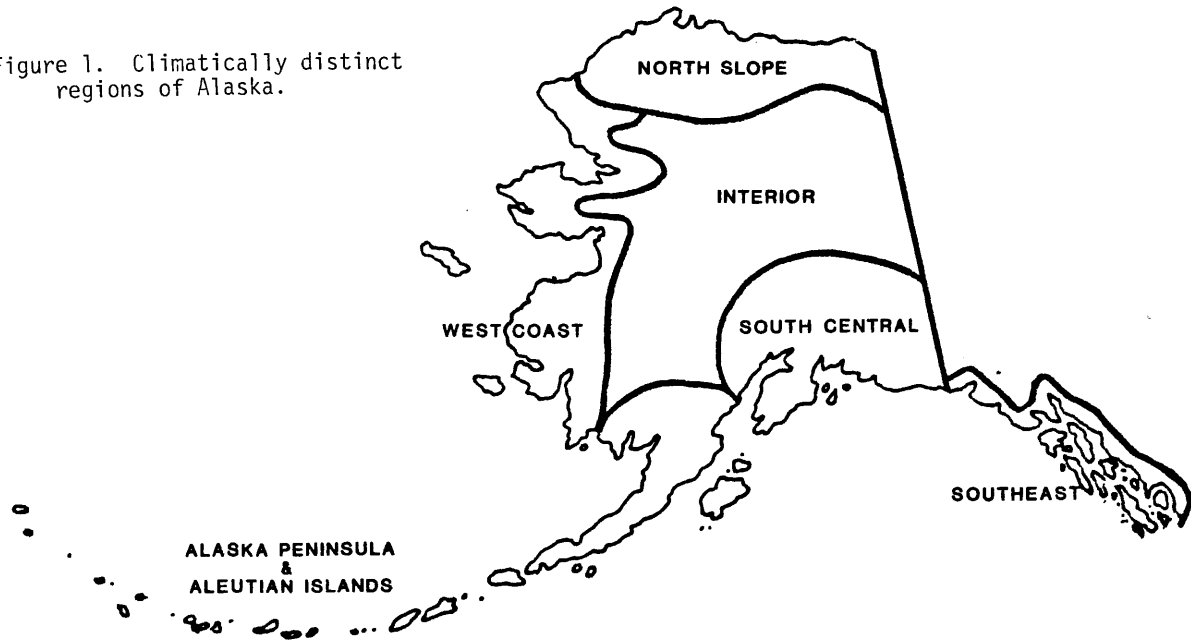

#### ARE ALASKAN RIPARIAN HABITATS THREATENED?

This is one of those good news-bad news answers. The good news is that by comparison to the rest of the Nation, Alaska still has most of its riparian habitats in good condition. The bad news is that threats to these habitats are real and increasing. Placer mining is probably Alaska's most visible problem today (Figs. 47-49). Oil and gas development and attendant transportation systems impact riparian zones (Figs. 50-51). On the Kenai River and other places, man's pursuit of recreation has caused impacts, too (Figs. 52-53). Streambank erosion near Alaskan "bush" communities result in the same makeshift control measures seen in the lower 48 states (Fig. 54). Logging can be devastating to stream systems (Fig. 55). Because the beach fringe was shown to be the most vital habitat for eagles, river otter, mink and other wildlife, this riparian habitat type is now being left uncut in U.S. Forest Service timber sales (Fig. 56).

#### CONCLUSIONS AND RECOMMENDATIONS

Although the literature is conspicuously silent about Alaska's riparian ecosystems, they do exist; they are valuable; and they are threatened. Any national riparian thrust should include Alaska, too.

One reason for the absence of "riparian literature" concerning Alaska may be the relative absence of use of the term "riparian" by scientists working in Alaska. Researchers

should recognize this when conducting literature searches and probe deeper using other key words such as "gravel", "stream alteration", "baseline studies", and "shoreline or beach fringe". Much of the work that has been done that might reveal useful information is categorized as general life history studies or assessment of impacts caused by development.

#### LITERATURE CITED

- American Fisheries Society, Western Division. 1980. Management and Protection of Western Riparian Stream Ecosystems. AFS. 24pp.
- Brinson, M.M., B.L. Swift, R.C. Plantico and J.S. Barclay. 1981. Riparian Ecosystems: Their Ecology and Status. USDI, Fish and Wildlife Service, FWS/OBS-81/17. Kearneysville, WV. 154pp.
- Jingfors, K.T. 1980. Habitat Relationships and Activity Patterns of a Reintroduced Muskox Population. M.S. Thesis. University of Alaska, Fairbanks. 116pp.
- Mould, E.D. 1977. Movement Patterns of Moose in the Colville River Area, Alaska. M.S. Thesis. University of Alaska, Fairbanks. 82pp.
- Robus, M.A. 1981. Muskox Habitat and Use Patterns in Northeastern Alaska. M.S. Thesis. University of Alaska, Fairbanks. 116pp.



# Patterns of Reproduction in Wright's Sycamore<sup>1</sup>

Jane H. Bock and Carl E. Bock<sup>2</sup>

---

Abstract.--In southeastern Arizona this tree produces large numbers of viable seeds that fall in a compact fruit shadow around parent individuals. Sexual reproduction usually fails due to drought or flash-flooding. Large numbers of seedlings and saplings grew in one site with permanent water and little flooding. Young trees grew in clumps, usually of similar-sized individuals, and away from mature tree canopy but always in the stream channel.

---

## INTRODUCTION

*Platanus wrightii* Wats. (Platanaceae) occurs in southern Arizona, southwestern New Mexico, and northern Mexico (Elias 1980). Glinsky (1977) reported on problems with natural regeneration in southeastern Arizona. We (Bock and Bock 1985) found causes of reproductive failure to be desiccation and death of embryos prior to germination, and loss of seedlings during flash floods. In the present study we measured patterns of seed fall, size classes of seedlings and saplings, and seedling distribution in relation to streambed characteristics and tree canopy, in three canyons in southeastern Arizona.

## METHODS

Field work was conducted between 1982 and 1984 in Lyle and Corral Canyons (Santa Cruz Co.), and in Carr Canyon (Cochise Co.). All sites are within the Coronado National Forest. Sexually mature trees (> 10cm basal stem diameter) were tagged and mapped in each study area.

---

<sup>1</sup> Paper presented at the North American Riparian Conference, University of Arizona, Tucson, April 16-18, 1985.

<sup>2</sup> Jane H. Bock and Carl E. Bock are Professors of Biology, University of Colorado, Boulder, Colo. 80309, and Co-Directors, Appleton-Whittell Research Ranch Sanctuary, National Audubon Society, P.O. Box 44, Elgin, Ariz. 85611.

There were 52 fruit-producing trees in Lyle and Corral Canyons which were sufficiently isolated that seedfall patterns could be constructed for them. We placed a meter tape up and downstream from each, and counted the numbers of fruits within one meter on each side of the tape, by 2-m intervals. This was done in January and March, 1983 and 1984, when seed fall and viability are at their maxima (Bock and Bock 1985).

No seedlings survived in Lyle or Corral Canyons during our study, apparently due to desiccation and flash flooding. However, there were large numbers of young trees in one 580-m section of Carr Canyon, along with 43 adults, where a spring kept the streambed moist year-round, and where flood scouring was limited by the small size of the watershed. Here, we counted and measured basal stem diameters of all trees in July, 1982. We examined the dispersion patterns of the young individuals by measuring nearest neighbor distances and comparing these with expected (random) values calculated from the overall density of individuals (Vandermeer 1981). We determined whether each young tree was under a canopy and compared these data with canopy frequency under 193 points at 3-m intervals along the streambed. At 47 places along the stream channel we constructed cross sectional profiles and plotted the sizes and locations of young sycamores in them.

## RESULTS AND DISCUSSION

Sycamore fruits were dispersed in a clearly defined pattern around parent trees (fig. 1), with 90% falling between 10 m upstream and 16 m downstream. More fruits were spread downstream (2,674 vs. 1,381 for all 52 trees; Chi-square = 412.3,

( $P < 0.001$ ). Fruits contained an average of 667 seeds ( $n = 30$ ). The 52 trees shed an average of 78 fruits in 2x58-m strips running up and downstream (fig. 1). Therefore, an average tree shed 449 seeds/m<sup>2</sup> in its seed shadow in the stream channel. Because seeds are up to 90% viable (Bock and Bock 1985), we conclude that plentiful supplies of sexual propagules are produced by Wright's sycamores in southeastern Arizona.

The smallest seedlings in Carr Canyon were about 100 times more common than saplings up to 10-cm basal stem diameter (fig. 2). Size and age were highly correlated ( $r = 0.87$ ,  $P < 0.01$ ,  $n = 20$ ), with the largest saplings being about 10 years old. If this represents a stable age/size distribution, then under ideal circumstances it appears that establishment, growth rate, and survivorship of Wright's sycamore seedlings to maturity can be quite high.

Young sycamores in Carr Canyon never occurred outside the stream channel ( $n = 315$ ), and they had a clumped dispersion within it. Expected (random) mean nearest neighbor distance was 2.04 m, while actual distance was 1.07 m. The basal stem diameter of each seedling and sapling was positively correlated with that of its nearest neighbor ( $r = 0.43$ ,  $P < 0.01$ ). We ruled out position in the stream cross section as a cause of this clumping, be-

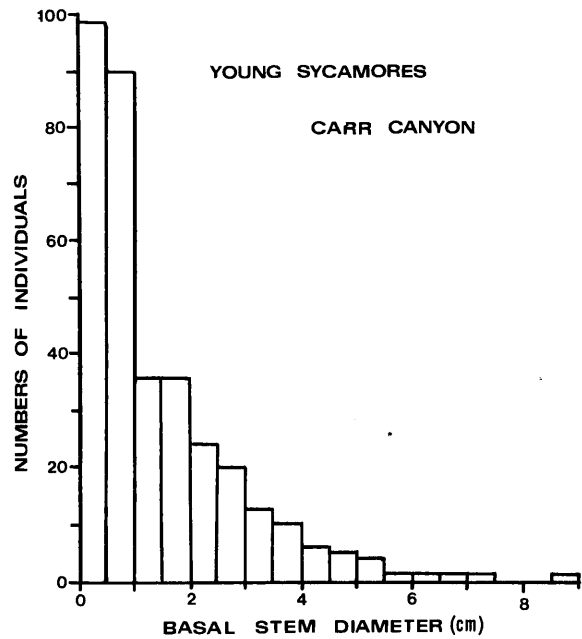

Figure 2. Size class distribution of young sycamores in Carr Canyon.

cause there were no clear patterns of seedling or sapling distribution in relation to stream depth or distance from the shoreline. However, young trees were more common away from mature tree canopy (actual canopy = 50%; 219 seedlings and saplings unshaded, 77 shaded; Chi-square = 68.1,  $P < 0.001$ ). Clumping may also be due to historic patterns of fruit fall.

Acknowledgments.--This project was supported by Joseph and Helen Taylor, and by Earthwatch and the Center for Field Research. We thank K. Bell, M. O'Shea-Stone, and Earthwatch volunteers for assistance.

LITERATURE CITED

Bock, J.H., and C.E. Bock. 1985. Reproductive ecology of *Platanus wrightii* in southeastern Arizona. Proc. 1983 Chihuahuan Desert Symposium, in press.

Elias, T. 1980. Trees of North America. 948 p. Van Nostrand Reinhold Co., New York, N.Y.

Glinsky, R.L. 1977. Regeneration and distribution of sycamore and cottonwood trees along Sonoita Creek, Santa Cruz County, Arizona. p. 124-127. In Importance, preservation, and management of riparian habitats: a symposium. USDA Forest Service General Technical Report RM-43. 217 p. Rocky Mountain Forest and Range Experiment Station, Fort Collins, Colo.

Vandermeer, J. 1981. Elementary mathematical ecology. 294 p. John Wiley and Sons, New York, N.Y.

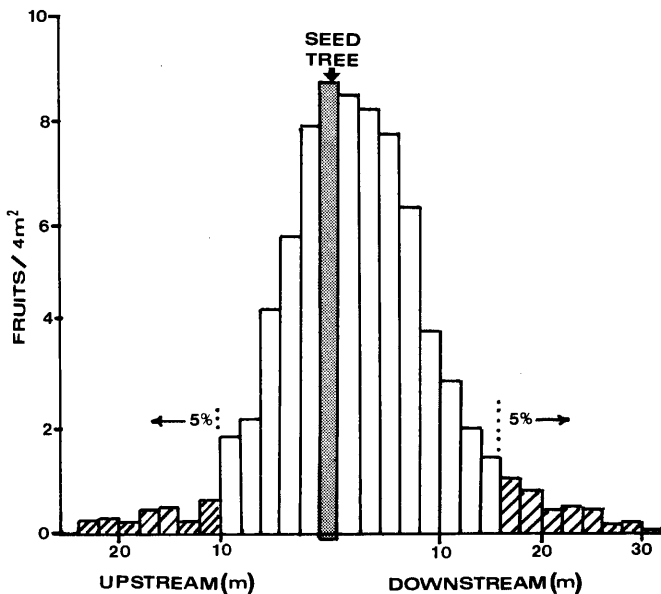

Figure 1. Average numbers of sycamore fruits shed various distances up and downstream from 52 mature trees.

# A Weighted-Means Ordination of Riparian Birds in Southeastern Wyoming<sup>1</sup>

Deborah M. Finch<sup>2</sup>

---

Abstract.--Variation among habitat associations of 31 riparian bird species in southeastern Wyoming was analyzed using a weighted-means ordination. Three principal components explained 86.7% of the variation among habitat associations of bird species. The components showed high positive loadings for variables associated with canopy, shrub size, and vegetation height.

---

## INTRODUCTION

Riparian communities in the central Rocky Mountains are comprised of shrub willow (*Salix* sp.) alone or cottonwood (*Populus angustifolia*, *P. sargentii*) with a shrub understory (Cannon and Knopf 1984). Cottonwoods are found in plains river bottoms, but shrub willow continues up mountain drainages to subalpine elevations of 3050 m. At high elevations, shrub willow is short and uniform, but as streams descend in elevation, shrub willow gains in volume and heterogeneity so that a vegetational gradient is formed.

This paper demonstrates the use of weighted-averages ordination for analyzing bird distributions along a riparian gradient in southeastern Wyoming. I used a procedure recommended by Maurer et al. (1981) in which several habitat variables measured randomly in different study areas are the basis for predicting species habitat associations. Variation among species is analyzed by computing a mean score for each species for each habitat variable, and then subjecting the species-habitat variables matrix to ordination analysis. Other techniques for evaluating habitat associations of bird species involve measurements of habitat variables at activity centers, perch sites, or nest sites. These methods typically require greater time and effort in data collection, and often involve logistical difficulties in the field (e.g., impeding physical structure of vegetation at non-random sites). The advantage of a weighted-means ordination is that it evaluates species pre-

ferences on a broad habitat scale; habitat and bird census data can be easily and quickly gathered, standardized, and interpreted by habitat managers (e.g., Anderson 1979).

## STUDY AREAS

Seven riparian study grids were established in shrub willow communities 24 km southeast of Laramie, Wyoming and 64 km west of Laramie in the Medicine Bow National Forest. Three additional sites were established in cottonwood and willow habitat. One site was located 2 km north of Arlington, Wyoming and two plots were established on the North Platte River near Saratoga, Wyoming. Ten study grids of 8.1 ha each were distributed over an elevational range of 933 m.

## METHODS

Avian populations were censused using the spot-map method during the breeding seasons (May to July) of 1982, 1983, and 1984. A minimum of eight censuses were conducted on each study area each year. The number of territorial, breeding pairs averaged across years for each study plot was used in the analysis. (Scientific names of bird species are listed in the Appendix.)

Vegetation structure was sampled in 1982 at 40 randomly selected grid intersections within the boundaries of each study plot. The point-centered quarter method was used to estimate plant densities. Thirty-four vegetation characteristics were measured following the sampling procedure suggested by Noon (1981) for shrub habitats. Redundant data were deleted, therefore reducing the data set to eight variables for statistical analysis (table 1).

I weighted the mean value of each habitat variable for each study plot by relative frequency of each bird species averaged over all years on a study plot (Maurer et al. 1981). A data matrix (31 species x 8 habitat variables) of weighted mean values for each habitat variable for each species was computed. The SPSS principal

---

<sup>1</sup>Poster paper presented at the symposium, Riparian Ecosystems and their Management: Reconciling conflicting uses, 1st North American Riparian Conference, Tuscon, Arizona, April 16-18, 1985.

<sup>2</sup>Deborah M. Finch is Research Wildlife Biologist for the Rocky Mountain Forest and Range Experiment Station, Laramie, Wyoming.

Table 1.--Factor loadings using weighted averages of 8 habitat variables for 31 bird species.

Variable	Principal Components		
	1	2	3
Shrub crown width (cm)	-0.46	0.78	-0.15
Shrub height (m)	0.07	0.92	0.26
Vertical foliage density (2-9 m) <sup>a</sup>	0.45	0.79	-0.10
Vertical foliage density (>9 m) <sup>a</sup>	0.89	-0.06	-0.07
Canopy cover (%)	0.91	0.20	-0.37
Effective vegetation height (m) <sup>b</sup>	-0.33	-0.21	0.87
Shrub density (#/m)	-0.06	0.15	0.26
Canopy height (m)	0.93	-0.01	-0.36
Eigenvalue	3.59	2.28	1.07
Variation explained	44.8	28.5	13.4

<sup>a</sup>Vertical foliage density is the number of contacts of vegetation falling against a vertical rod graduated into the following intervals: 0-0.3 m, 0.3-1 m, 1-2 m, 2-9 m, and >9 m.

<sup>b</sup>Effective vegetation height is the height at which a 20-cm wide board is more than 90% obscured by vegetation at a distance of 5 m.

components procedure was used to analyze this matrix (Nie et al. 1975). Interpretation of the axes was improved by varimax-rotation of the components.

## RESULTS

The first three principal components had eigenvalues >1.0 and accounted for 86.7% of the variation among habitat associations of 31 bird species (table 1). The varimax-rotated factors showed high loadings for those variables most important in explaining variation in habitat selection among species.

Component 1 accounted for 44.8% of the total variance, and was characterized by high positive loadings for canopy height, % canopy cover, and vertical foliage density in the >9 m interval. Thus, component 1 emphasized canopy characteristics that varied as riparian sites changed from those dominated by trees to those dominated by shrubs. Component 2 accounted for 28.5% of the total variance and showed high positive loadings for shrub height, shrub crown width, and vertical foliage density at the 2-9 m interval. It therefore stressed characteristics associated with the upper stratum of shrubs. Component 3 explained 13.4% of the variation and indicated a high positive loading for effective vegetation height, an index of herbaceous vegetation volume.

A plot of species on the first two principal components suggested a gradation of species associations along habitat continuums, although three general groups were distinguishable (fig. 1). A distinct group comprised of only three species, Wilson's Warbler, White-crowned Sparrow, and Lincoln's Sparrow, had low scores on the first

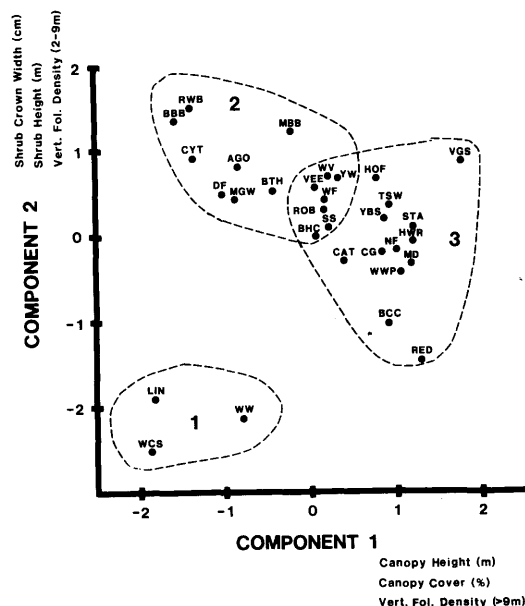

Figure 1. Ordination of 31 bird species. Species codes and number of pairs used in the ordination are given in the Appendix.

two components. This group contained those species confined to high elevation (2500-3000 m) riparian habitats dominated by short and uniform shrub willow and with no overstory canopy. A second group had low scores for the first component and high scores for the second component. This group was composed of species that were most abundant in mid-elevation (2200-2500 m) habitats with tall shrub willow and few trees. The third group had high scores on the first component and variable scores on the second. Species representative of mature cottonwood stands with a heterogeneous shrub understory comprised this group. Species common in both mid-elevation shrub willow habitats and low-elevation cottonwood habitats had scores approaching zero for both components and were plotted in the center of the ordination. These species formed an intermediate subgroup between the second and third aggregations and included such widely distributed species as American Robin, Veery, Yellow Warbler, Brown-headed Cowbird and Song Sparrow.

## DISCUSSION

When the habitat associations of a group of species are described, the level or order of habitat selection should be implicitly recognized. In reviewing the concept of hierarchical ordering of habitat selection, Johnson (1980) stated that a selection process will be of higher order than another if it is conditional upon the latter. Habitat selection in this paper refers to second-order selection (i.e., selection of local site patterns) (Weins 1973) which is conditional upon geographical range (first-order selection) but does not define patterns of usage within a territory (third-order selection). The results of this

analysis suggest that weighted-means ordination is a useful technique for examining second-order selection processes along a gradient of riparian habitat types. Many habitat models developed for managing single species (e.g., Habitat Suitability Index models, U. S. Fish and Wildlife Service 1981) are based on habitat measurements of second-order selection variables. Because these same variables are also used in weighted-averages ordination of multiple species, this type of ordination analysis may be a worthwhile method for selecting factors to be used in both single- or multiple-species management.

Weighted-means ordination may not provide the level of resolution needed to distinguish differences in habitat preference within a species or between ecologically similar species (Maurer et al. 1981). However, it offers more information than a simple list of species by habitat type because it 1) arranges species preferences along a continuum of environmental variables, thus identifying dissimilar species and grouping similar species, 2) weights selection of habitat types by estimates of density of each species, and 3) defines a limited subset of variables that habitat managers can measure and interpret.

#### ACKNOWLEDGMENTS

I thank S. H. Anderson, W. Eddleman, R. Greer, M. G. Raphael, Q. Skinner, and M. Smith for commenting on the manuscript and P. A. Gutzwiller for drafting the figure.

#### LITERATURE CITED

- Anderson, S. H. 1979. Habitat structure, succession and bird communities. p. 9-21. In Proceedings of the Workshop Management of Northcentral and Northeastern Forests for Nongame Birds, R. M. DeGraaf, ed. USDA Forest Service General Technical Report. NC-51, North Central Forest Experiment Station, St. Paul, MN.
- Cannon, R. W. and F. L. Knopf. 1984. Species composition of a willow community relative to seasonal grazing histories in Colorado. Southwestern Naturalist 29:234-237.
- Johnson, D. H. 1980. The comparison of usage and availability measurements for evaluating resource preference. Ecology 61:65-71.
- Maurer, B. A., L. B. McArthur, and R. C. Whitmore. 1981. Habitat associations of birds breeding in clearcut deciduous forests in West Virginia. p. 167-172. In The Use of Multivariate Statistics in Studies of Wildlife Habitat, D. E. Capen, ed. USDA Forest Service General Technical Report RM-87, Rocky Mountain Forest and Range Experiment Station, Fort Collins, CO.
- Nie, N. H., C. H. Hull, J. G. Jenkins, K. Steinbrenner, and D. H. Bent. 1975. Statistical package for the social sciences. Second edition. McGraw-Hill, New York, N.Y.
- Noon, B. R. 1981. Techniques for sampling avian habitats. p. 42-52. In The Use of Multivariate Statistics in Studies of Wildlife Habitat, D. E. Capen, ed. USDA

- Forest Service General Technical Report RM-87, Rocky Mountain Forest and Range Experiment Station, Fort Collins, CO.
- U.S. Fish and Wildlife Service. 1981. Standards for the development of Habitat Suitability Index models. ESM 103. U.S. Department of the Interior, Fish and Wildlife Service, Division of Ecology Service n.p.
- Wiens, J. A. 1973. Pattern and process in grassland bird communities. Ecological Monographs 43:237-270.

#### APPENDIX

Scientific names and codes of bird species mentioned in the text, and mean number of territorial pairs per year used in the ordination.

Species Name	Scientific Name	No. Pairs
Mourning Dove (MD)	<u>Zenaida macroura</u>	10.3
Broad-tailed Hummingbird (BTH)	<u>Selasphorus platycercus</u>	22.0
Yellow-bellied Sapsucker (YBS)	<u>Sphyrapicus varius</u>	3.3
Northern Flicker (Red-shafted) (NF)	<u>Colaptes auratus</u>	5.7
Western Wood-Pewee (WWP)	<u>Contopus sordidulus</u>	8.3
Willow Flycatcher (WF)	<u>Empidonax traillii</u>	3.0
Dusky Flycatcher (DF)	<u>E. oberholseri</u>	9.0
Tree Swallow (TSW)	<u>Tachycieta bicolor</u>	11.7
Violet-green Swallow (VGS)	<u>T. thalassina</u>	5.7
Black-capped Chickadee (BCC)	<u>Parus atricapillus</u>	3.0
House Wren (HWR)	<u>Troglodytes aedon</u>	38.3
Mountain Bluebird (MBB)	<u>Sialia currucoides</u>	3.0
Veery (VEE)	<u>Catharus fuscenscens</u>	20.0
American Robin (ROB)	<u>Turdus migratorius</u>	63.0
Gray Catbird (CAT)	<u>Dumetella carolinensis</u>	6.0
European Starling (STA)	<u>Sturnus vulgaris</u>	4.0
Warbling Warbler (WV)	<u>Vireo gilvus</u>	16.3
Yellow Warbler (YW)	<u>Dendroica petechia</u>	136.3
American Redstart (RED)	<u>Setophaga ruticilla</u>	3.0
MacGillivray's Warbler (MGM)	<u>Oporornis tolmiei</u>	6.7
Common Yellowthroat (CYT)	<u>Geothlypis trichas</u>	7.0
Wilson's Warbler (WW)	<u>Wilsonia pusilla</u>	42.7
Song Sparrow (SS)	<u>Melospiza melodia</u>	42.7
Lincoln's Sparrow (LIN)	<u>M. lincolni</u>	86.7
White-crowned Sparrow (WCS)	<u>Zonotrichia leucophrys</u>	25.0
Red-winged Blackbird (RWB)	<u>Agelaius phoeniceus</u>	4.3
Brewer's Blackbird (BBB)	<u>Euphagus cyanocephalus</u>	19.0
Common Grackle (CG)	<u>Quiscalus quiscula</u>	3.0
Brown-headed Cowbird (BHC)	<u>Molothrus ater</u>	8.0
House Finch (HOF)	<u>Carpodacus mexicanus</u>	3.0
American Goldfinch (AGO)	<u>Carduelis tristis</u>	4.7

# Transplanting Native Sonoran Desert Plants<sup>1</sup>

George A. Ruffner<sup>2</sup>, Donald A. Fedock<sup>3</sup>, and Steven W. Carothers<sup>2</sup>

Plant community structure and composition determine the 'value' of revegetated habitats to wildlife, particularly birds. Revegetation projects in Sonoran Desert communities are often dependent on non-native plants, however. Widespread introductions of exotic plant species adversely affect wildlife. Insects found on many exotic species are not capable of supporting native birds. Furthermore, structural characteristics of many plants may preclude their utilization by native animals for nesting or cover. Non-native plants are poorly adapted to prevailing environmental conditions and often require intensive management. Even though these plants are often touted as 'arid land' or 'drought tolerant' they frequently use more water than do native species.

Cacti and other native succulents have been widely used in revegetation projects for a number of years. Unfortunately, 'cactus patches' are not representative of existing Sonoran Desert communities. Woody native perennials from commercial sources are usually raised from seed. Limited availability of large-stemmed individuals, due to slow growth rates and high costs, precludes their use in revegetation projects.

Mitigation measures which anticipate revegetation features could benefit from utilizing mature native plants. Wildlife use of habitats revegetated in this manner is greater and more rapid than in habitats solely with saplings.

This paper describes a method for transplanting woody native plants in Sonoran Desert communities. Mesquite, palo verde, ironwood, catclaw acacia and other perennials may be transplanted

(Table 1). We have transplanted these plants with a survival rate exceeding 90% for some species. This technique is labor intensive and time consuming, but it is possible to revegetate large sites given adequate lead time and planning. It has applications in flood control projects, habitat restoration, developments, and as mitigation for habitat losses.

Table 1. Survivorship of transplanted Sonoran Desert plants during 1983 and 1984 near Tucson, Arizona.

----- ≥ 90% -----
blue palo verde ( <i>Cercidium floridum</i> )
foothills palo verde ( <i>Cercidium microphyllum</i> )
bursage ( <i>Ambrosia deltoidea</i> )
creosote ( <i>Larrea tridentata</i> )
desert willow ( <i>Chilopsis linearis</i> )
ironwood ( <i>Olneya tesota</i> )
mesquite ( <i>Ecosopsis</i> spp.)
----- ≥ 80% -----
brittlebush ( <i>Encelia farinosa</i> )
----- ≥ 70% -----
catclaw ( <i>Acacia greggii</i> )
----- Unknown -----
desert hackberry ( <i>Celtis pallida</i> )
gray thorn ( <i>Ziziphus obtusifolia</i> )

<sup>1</sup> Paper presented at the First North American Riparian Conference, Riparian Ecosystems and Their Management: Reconciling Conflicting Uses, April 16-18, 1985, Tucson, Arizona.

<sup>2</sup> SWCA, Inc., Environmental Consultants, Flagstaff, Arizona.

<sup>3</sup> Don's Desert Digs, Ajo, Arizona

# Recovery Processes in Southeastern Riverine Wetlands<sup>1</sup>

R. R. Sharitz and L. C. Lee<sup>2</sup>

---

Abstract.--Perturbations to riverine wetlands in the Southeast often degrade existing communities or change the potential for wetland sites to support those communities. Disturbances that are in scale with wetland ecosystems can lead to normal recovery processes. The greatest changes to wetlands occur when the magnitude of the disturbance exceeds or is asynchronous with natural environmental limits.

---

## INTRODUCTION

In the Southeastern United States, development of water resources for agricultural, industrial and recreational uses resulted in the loss of 3,121,000 ha of wetlands between the mid-1950's and mid-1970's (Hefner and Brown 1984). Many remaining freshwater wetlands in the Southeast are associated with major rivers whose discharges are managed through dams and other water control structures (Wharton and Brinson 1979). Often, regulation of the hydrographs of these rivers has resulted in perturbations to associated wetland ecosystems (Leopold and Wolman 1957; Gregory and Walling 1973). Usually, managed discharges are in scale with the geomorphic, geochemical and biotic limits of the watershed in which they occur. The resulting perturbation to floodplain wetlands therefore may be asynchronous, but is generally in proportion with the potential for the wetlands to tolerate stress, and subsequently to recover to an original (pre-disturbance) ecosystem state. Several examples of the resiliency of wetland ecosystems to disturbance and the process of natural successional recovery following disturbance to wetlands have been documented throughout the Region (Brinson et al. 1984; Sharitz et al. 1974).

---

<sup>1</sup>Poster presented at the first North American riparian conference, "Riparian Ecosystems and Their Management: Reconciling Conflicting Uses." [Tucson, AZ, April 16-18, 1985].

<sup>2</sup>R. R. Sharitz and L. C. Lee are Head and Research Manager, respectively, Division of Wetlands Ecology, University of Georgia Savannah River Ecology Laboratory, Aiken, SC. Research conducted under Contract DE-AC09-76SR00819 between the U.S. Department of Energy and the University of Georgia.

Recently, there has been an increase in the rate at which conversions of wetlands occur, and in the scale of industrial and water resources developments within wetland ecosystems (Tiner 1984). As a result, perturbations to wetlands have begun to exceed natural environmental limits (e.g. managed discharges that exceed river flood stages) or have changed the timing of major hydrologic events (Sharitz et al. in press). When such circumstances develop, the structure of wetland communities, and ecosystem processes characteristic of wetlands, show signs of change or degradation (Brown et al. 1979). These changes include development of less conservative nutrient cycles (Peterjohn and Correll 1984; Brinson et al. 1984), failure to complete organic matter processing (Minshall et al. 1983), and decreases in primary productivity (Conner et al. 1981). If stresses to wetland ecosystems are of sufficient magnitude, the potential for wetland sites to support original communities can be altered and wetlands of significantly different character (and presumably function) may dominate.

On the U.S. Department of Energy's Savannah River Plant (SRP) near Aiken, South Carolina, portions of a 3800 ha river floodplain dominated by bald cypress (*Taxodium distichum*) and water tupelo (*Nyssa aquatica*) have been differentially exposed to both thermal and sedimentation stress since the mid-1950's. These wetlands receive heated effluent discharges from the cooling systems of several nuclear production reactors. However, major portions of the SRP cypress-tupelo wetlands remain relatively undisturbed by thermal effluents, but subject to managed river discharges.

The range of perturbations to SRP wetlands provides an excellent example of the responses of similar floodplain forest communities to different scales of disturbance, and to disturbances that occur in and out of synchrony with natural wetland ecosystem processes. It has been suggested that the patterns of response to perturbation exhibited by SRP cypress-tupelo wetlands largely depend on the magnitude and timing of disturbance events (Sharitz et al. in press).

Three major types of response are: (1) following desynchronized floods, SRP cypress-tupelo wetlands recover to relatively pristine ecosystem states via natural regeneration, (2) responding to chronic low level disturbances, SRP cypress-tupelo forests exhibit a slow degradation of community structure and regenerative potential, and (3) following large-scale disturbance, SRP cypress-tupelo wetlands undergo rapid degradation of community structure accompanied by a transition to a different ecosystem state.

#### RECOVERY TO PRISTINE ECOSYSTEM STATES VIA NATURAL REGENERATION

Recovery of cypress-tupelo wetlands by natural regeneration presumes that the degree of disturbance is not chronic or of sufficient magnitude to cause permanent alteration of the wetland or to eliminate the potential for forest regeneration. Perturbations of this type (e.g. floods associated with discharges from dams) are usually in scale with the physical limits of the floodplain. However, the timing of managed releases can vary widely. Major discharges during the growing season that cause rapid changes in floodplain water levels have caused widespread mortality to seedlings, saplings and undergrowth species in SRP cypress-tupelo forests (Sharitz et al. in press). But, because unseasonal flood events are not common and not so large that they are out of scale with the water level changes to which the wetlands are adapted, recovery of stands following such disturbances is possible. Indeed, SRP cypress-tupelo wetlands maintain the potential to regenerate after three decades of flow regulation of the Savannah River.

#### SLOW DEGRADATION OF WETLAND COMMUNITY STRUCTURE AND REGENERATIVE POTENTIAL

On the SRP, slow degradation of cypress-tupelo stands with accompanying loss of regenerative potential is caused by chronic, low level perturbation. For example, inputs of moderately heated reactor effluents have caused disturbance to SRP floodplain cypress-tupelo forests. Effects include: (a) deterioration of structure in the canopy, subcanopy and undergrowth strata, (b) increased stemwood production in canopy dominants that survive the chronic stress, and (c) increased detrital production by the wetland community. The net effect of chronic disturbances in SRP study sites has therefore been to release canopy dominants that are capable of tolerating stress, but to simultaneously cause mortality to intermediate-aged and juvenile individuals.

#### RAPID DEGRADATION OF WETLAND COMMUNITY STRUCTURE AND TRANSITION TO A DIFFERENT ECOSYSTEM STATE

Rapid degradation of community structure in portions of SRP cypress-tupelo forests has been caused by the combined effects of thermal stress and sedimentation. Discharges of large

volumes of hot reactor effluents caused rapid mortality of the majority of species in and adjacent to the floodplains of reactor streams. Sedimentation from these same channels formed large deltas on former cypress-tupelo wetland sites where these streams enter the Savannah River floodplain. As a result, the physical environment in the former stream and floodplain wetland sites was significantly altered. On several SRP reactor streams, continuous perturbation by heated effluents and sedimentation prevents wetland recovery. However, cessation of reactor discharges to one stream in 1968 allowed these highly disturbed wetland environments to revegetate. The recovering communities in no way resemble the original cypress-tupelo forests. On the contrary, these post-thermal recovering sites support a mosaic of herbaceous marsh and scrub-shrub wetlands. Very little regeneration of cypress and tupelo has occurred.

#### LITERATURE CITED

- Brinson, M. M., H. D. Bradshaw and E. S. Kane. 1984. Nutrient assimilative capacity of an alluvial floodplain swamp. *J. Applied Ecology* 21: 1041-1057.
- Brown, S., M. M. Brinson and A. E. Lugo. 1979. Structure and function of riparian wetlands. p. 17-31. In Johnson, R. R. and J. F. McCormick (tec. coords.). *Strategies for protection and management of floodplain wetlands and other riparian ecosystems*. USDA For. Serv. Gen. Tech. Rep. WO-12. Washington, DC.
- Conner, W. H., J. G. Gosselink and R. T. Parrondo. 1981. Comparison of the vegetation of three Louisiana swamp sites with different flooding regimes. *Am. J. Bot.* 68:320-331.
- Gregory, K. J. and D. E. Walling. 1973. Drainage basin form and process. 458 p. Halsted Press, NY.
- Hefner, J. M. and J. D. Brown. 1984. Wetland trends in the Southeastern U.S. 5th Annual Meeting of the Society of Wetland Scientists, May 23-25, 1984. San Francisco.
- Leopold, L. B. and M. G. Wolman. 1957. River channel patterns: braided, meandering and straight. p. 39-85. U. S. Geol. Survey 282-B.
- Minshall, G.W., R. C. Peterson, K. W. Cummins, T. L. Bott, J. R. Sedell, C. E. Cushing and R. L. Vannote. 1983. Interbiome comparison of stream ecosystem dynamics. *Ecol. Monog.* 53:1-25.
- Peterjohn, W. T. and D. L. Correll. 1984. Nutrient dynamics in an agricultural watershed: observations on the role of a riparian forest. *Ecology* 65:1466-1475.



Sharitz, R. R., J. E. Irwin and E. J. Christy.  
1974. Vegetation of swamps receiving reactor  
effluents. *Oikos* 25:7-13.

Sharitz, R. R., R. L. Schneider and L. C. Lee.  
Composition and regeneration of a disturbed  
riverine floodplain wetland in South Carolina.  
*Proc. EPA Bottomland Hardwoods Symp. St.*  
*Francisville, LA. (in press).*

Tiner, R. W. 1984. Wetlands of the United States:  
current status and recent trends. 59 p.

National Wetlands Inventory. U.S. Fish  
& Wildl. Ser. Washington, DC.

Wharton, C. H. and M. M. Brinson. 1979.  
Characteristics of southeastern river systems.  
p. 32-40. *In* Johnson, R. R. and J. F.  
McCormick (tec. coords.). Strategies for  
protection and management of floodplain  
wetlands and other riparian ecosystems.  
USDA For. Ser. Gen. Tec. Rep. WO-12.  
Washington, DC.

# Structural Anadromous Fishery Habitat Improvement on the Siskiyou National Forest<sup>1</sup>

Bruce D. Sims and Lee D. Johnson<sup>2</sup>

---

**Abstract.**--Three separate strategies for allowing anadromous fish passage through culverts are discussed. These include: 1) construction of stepped log weirs to raise the pool level at the culvert outlet; 2) retrofitting circular culverts with a baffle system; and 3) use of an open-bottomed arch-type culvert. In addition, several log and gabion structures used to create pool habitat are discussed. All examples presented have survived several seasons and have achieved their fishery enhancement objectives.

---

## INTRODUCTION

The Siskiyou National Forest, which has the highest value fishery of any National Forest outside Alaska, has been involved in anadromous fish habitat improvement since 1967. This paper presents three different approaches the Siskiyou has taken to allow fish passage through obstructive culverts and describes three structures which have been constructed to create deep pools for rearing habitat and for trapping spawning gravel.

## CULVERT PASSAGE BARRIERS

### Velocity Barriers

In 1981, an 8½-foot circular corrugated steel culvert was replaced with a 6½-foot rise, 13-foot span pipe arch. Although this pipe arch allowed easy fish passage, the inlet end footing was undercut during the first high flows: the arch constricted the water flow, thereby accelerating its velocity over the native channel bed material. Grout was subsequently pumped under the exposed footing, but it too was soon undercut. Riprap was then placed at the arch outlet to create a stable base level which more nearly matched the original channel's level. This second strategy induced backfilling through the pipe arch and created a passable channel (fig.1).



Figure 1.--Pipe arch used to allow fish passage.

Another approach used to correct a velocity barrier is the addition of a baffle system to the floor of an in-place corrugated circular culvert. Rather than replacing worn culverts, it has become common practice on the Siskiyou N.F. to protect the worn culvert bottom with a reinforced concrete apron. When the concrete is poured, it is relatively easy to embed baffle supports cut from steel I-beams into the concrete. These I-beams are precut to desired dimensions and holes pre-drilled to allow wooden baffles to be easily bolted into place (fig.2). Adjusting the system in the field is a simple matter of raising or lowering the wooden baffles if observation deems it necessary. To date, two large culverts have been successfully fitted with these wooden baffles. One of these, a 7-foot-diameter by 80-foot-long culvert, is sloped at 6.5 percent.

---

<sup>1</sup>Poster session paper, 1985 North American Riparian Conference. University of Arizona, Tucson, April 16-18, 1985.

<sup>2</sup>Bruce D. Sims is a Hydrologist, Siskiyou National Forest, Gold Beach, Oregon and Lee D. Johnson is a Fishery Biologist, Siskiyou National Forest, Brookings, Oregon.

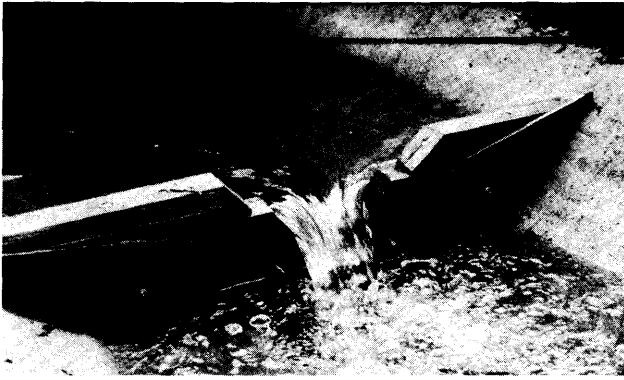

Figure 2.--Retrofitted culvert baffles.

#### Culvert Entry Barriers

Culvert outlets that are higher than three feet above the plunge pool generally inhibit anadromous fish entry into the pipe. Jump success depends on both pool depth and location of the standing wave (reversals) below the culvert.

Plunge pool elevations below culverts can be raised by a series of log weirs. In the example shown below (fig.3), the pool was raised three feet by a series of five large log weirs. Jumps between the structures ranged from about twelve inches to a maximum of twenty-eight inches.

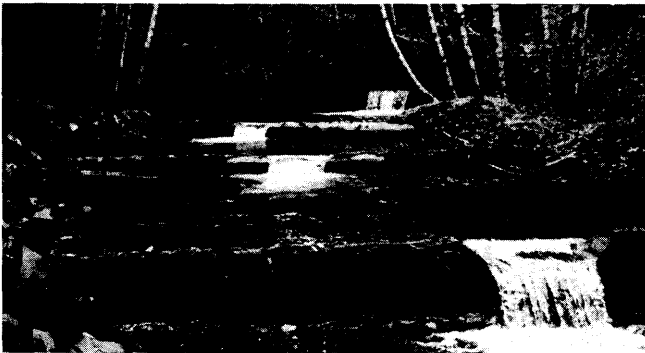

Figure 3.--Log weirs used to correct a culvert entry barrier.

Following placement of the log weirs, chain-link fence was tacked to the upstream edge of the logs and spread upstream along the channel bed. The fencing catches bedload and organic debris, which holds the structures in place and reduces the potential for water scouring beneath the weir. Riprap was placed at the ends of each structure to create the log weir's lateral boundaries and protect the alluvial channel banks.

A notch was cut in each log weir and sized to insure several inches of water depth, during low flow, to allow smolt migration downstream. The notches also concentrate flow and can set up favorable standing waves, which encourage fish jumps. A wooden weir was also fitted in the culvert outlets to create favorable standing waves below the pipe and deeper water inside the lower end of the culvert where the fish land.

During the second spawning season after construction of these five stair-stepped log weirs, over 42 chinook (King) salmon were counted above the culvert. This quantity of fish above the culvert--even before the stream's run has fully recovered--indicates high passage success.

#### HABITAT IMPROVEMENT

Instream structures have been built in a variety of configurations, using gabions or logs that are available at or near the site. The most effective structures to date have been the wing deflector gabion in large streams and the reverse V or perpendicular log weir in smaller streams (fig.4-fig.6).

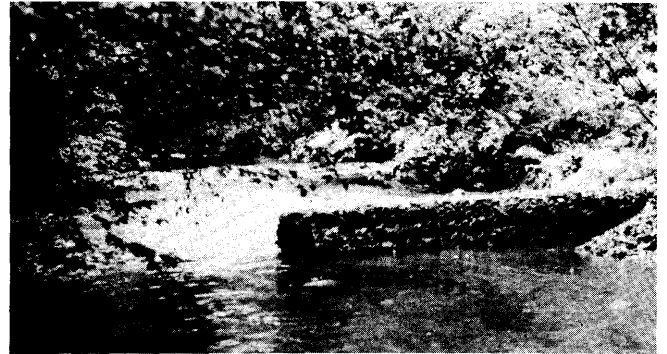

Figure 4.--Wing deflector gabion.



Figure 5.--Reverse V gabion.

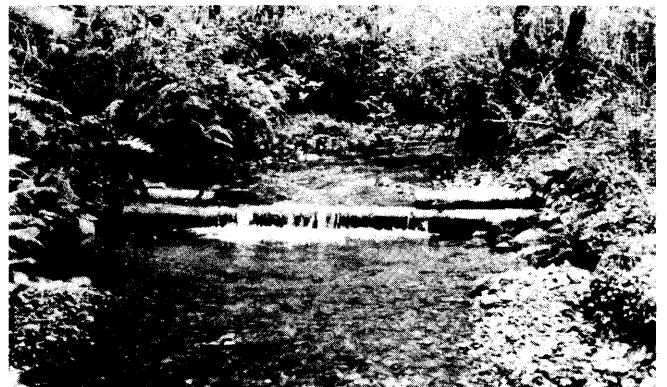

Figure 6.--Small log weir.

Log structures in small streams can be built with ten-to-twenty-inch-diameter logs, cabled together to achieve the desired height, without heavy equipment. A twenty-foot small log structure can be built by a crew of three in half a day.

Gabions built in small streams are wired together and filled with three-to-eight-inch rocks from the stream. Half-inch cable through the center of the gabion provides strength and integrity to the overall structure. Gabions are generally twelve to eighteen inches high at the weir to minimize the reduction of channel gradient above the structure, while creating a fall of

sufficient height to induce pool scour. Wing deflector gabions with a total height of three feet, placed at approximately a 35 degree angle from the stream bank, have been built with good success. A three-by-three-foot hand-constructed gabion (including bed leveling) can generally be built at one-and-a-half-feet per man hour.

The habitat improvement structures presented herein have been extensively used for spawning and rearing habitat. Sampling (by electroshocking) in improved areas and control areas has revealed an increase of greater than 300 percent in juvenile fish populations.

# Small Mammal Community Structure in Old Growth and Logged Riparian Habitat<sup>1</sup>

Lee H. Simons<sup>2</sup>

Abstract.--Species richness and evenness were measured in small mammal communities from old growth and logged riparian habitat. Six species occurred in both habitats, while *Clethrionomys occidentalis* occupied only old growth. Similarities in understory vegetation, and proximity of old growth to the logged area, may promote similar communities in each habitat.

Commercial logging clearly affects community characteristics of small mammals (Gashwiler 1970; Kirkland 1977). Small mammals eat significant amounts of conifer seeds, insects, and mycorrhizal fungi (Maser et al. 1978). This study compares small mammal communities from adjacent old growth and logged riparian habitats.

## METHODS

Two study sites were established along Squaw Valley Creek on the southern slope of Mt. Shasta, Siskiyou County, California. The upper site was in old growth forest at an elevation of 1400 m, while the logged site was 1.5 km downstream at an elevation of 1260 m. The logged area was clearcut, except for several "seed-producing" trees, in 1967; large stumps indicated that old growth existed there prior to logging. An abrupt transition between habitats occurred 0.5 km upstream from the logged study site.

For each site, 26 trap stations were randomly assigned to either creek bank at intervals of about 9 m (range = 5-15 m). At each trap station two Sherman livetraps were set with rolled oats: the first within 5 cm of water, the second at least 30 cm away from water. Each study site was trapped for 36 continuous hours (1800 to 0600 h) on four occasions in 1982: 17-19 July, 31 July-2 Aug., 7-9 Aug., 30 Aug.-1 Sept., and 30 Aug.-1 Sept., 10-12 Sept., 17-19 Sept., 24-26 Sept. for the old growth and logged areas, respectively. Traps were checked at least every 12 hours and captured mammals were permanently removed.

<sup>1</sup>Paper presented at the first North American Riparian Conference (University of Arizona, Tucson, April 16-18, 1985).

<sup>2</sup>Lee H. Simons is a graduate student in the Department of Zoology, Arizona State University, Tempe, Arizona. I thank Laurie Stuart Simons for help in the field and with analysis, and John Clark and College of the Siskiyous, Weed, California for the loan of small mammal traps.

Overstory and understory vegetation were quantified at each site with the point-quarter method and ten random points (Cox 1976). Plants were identified with Munz (1973). Small mammal diversity and equitability were calculated with the Shannon-Wiener function (Krebs 1985). Statistical tests follow Sokal and Rohlf (1981).

## RESULTS

One hundred and fifty-six small mammals, representing 7 species, were captured (fig. 1). Six species occurred in both habitats, while *Clethrionomys occidentalis*, the red-backed vole, occurred only in old growth. The overall small mammal frequency distributions were weakly associated with habitat type ( $P = .05$ ). If red-backed

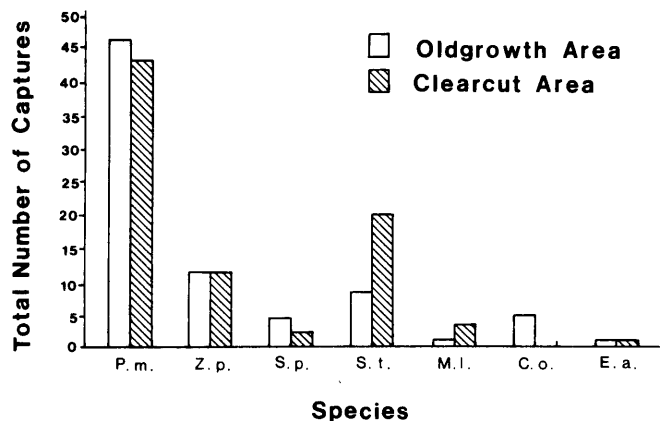

Figure 1.--Total number of captures of seven species of small mammals in two habitat types. P.M. = *Peromyscus maniculatus* (deer mouse), Z.P. = *Zapus princeps* (western jumping mouse), S.P. = *Sorex palustris* (northern water shrew), S.T. = *Sorex trowbridgei* (trowbridge shrew), M.L. = *Microtus longicaudus* (longtail vole), C.O. = *Clethrionomys occidentalis* (red-backed vole), E.A. = *Eutamias amoenus* (yellow pine chipmunk). Statistical results are given in the text.

voles are excluded, the remaining frequency distributions are independent of habitat type ( $P > .5$ ). Small mammal diversity and equitability were 1.83 and 0.65 in the old growth site, and 1.76 and 0.68 in the logged site. Neither measure is significantly different between habitats ( $P > .5$ ;  $F$  tests).

Vegetative characteristics for each habitat are summarized in table 1. Density and average basal area of overstory were drastically lowered in the logged area despite a 15 year lapse since logging. Erosion and poor reforestation management may have hindered regrowth. Understory vegetation also differed between habitats, but the contrasts were less extreme. Alder was dominant in both understories, while willow partially replaced dogwood in the logged area. Total cover from understory vegetation was similar between habitats because increased basal area offset decreased density in vegetation on the logged site. Increased herbaceous growth in the logged habitat also appeared to increase cover.

#### DISCUSSION

The strong similarities in small mammal community structure between old growth and logged habitats was not anticipated. Small mammal communities change extensively in response to logging (Gashwiler 1970; Ramirez and Hornocker 1981); and the sparse overstory in the logged area contrasted sharply with the dense old growth forest. But each

Table 1.--Summary of vegetative characteristics of overstory and understory in (A) old growth, and (B) logged habitat. Probabilities of differences by chance: NS = ( $P > .1$ ), \* = ( $0.1 > P > .05$ ), \*\* = ( $.05 > P > .01$ ), \*\*\* = ( $P < .001$ )<sup>1</sup>.

SPECIES	DENSITY		AVE. BASAL AREA (cm <sup>2</sup> )		RELATIVE FREQUENCY	
	A	B	A	B	A	B
OVERSTORY						
<u>Abies</u>						
concolor	44	17	2000	1000	27	30
<u>Pinus</u>						
lambertiana	22	3	9900	4600	19	30
<u>Pseudotsuga</u>						
menziesii	70	13	8600	1600	27	26
<u>Calocedrus</u>						
decurrens	39	13	2900	2000	27	35
Total/Mean	174	46	5815	1663	100	100
UNDERSTORY	***		***		NS	
<u>Abies</u>						
concolor	1133	88	13	29	21	6
<u>Alnus</u>						
tenuifolia	3220	2133	35	60	37	53
<u>Chrysolepis</u>						
sempervirens	477	234	5	7	16	12
<u>Salix</u>						
speciosa	0	155	0	12	0	11
<u>Ceanothus</u>						
velutinus	179	155	8	323	5	6
<u>Cornus</u>						
nuttallii	954	157	8	6	21	12
Total/Mean	5963	2922	23	64	100	100
	**		*		***	

<sup>1</sup>T-tests for density and basal area; Tests of independence for relative frequency.

study site was close to the other habitat (0.5-1.0 km) which insured that mammal species were available for colonization. Also, cover from understory vegetation was similar in both areas. These data suggest that understory cover supersedes overstory in providing habitat for most of the small mammals in this study.

Red-backed voles are a notable exception. Clearcuts generally support these voles only when logs or other debris are present (Tevis 1956). Data presented here indicate that vegetative cover alone is not sufficient to retain these voles. Apparently debris provides some additional resource other than cover. Red-backed voles feed primarily on mycorrhizal fungi and are important dispersers of mycorrhizal spores to sapling roots (Maser et al. 1978). Because mycorrhizae enhance growth rates of trees in coniferous forests, retention of voles (as dispersers of mycorrhizae) may assist in stand regeneration (Maser et al. 1978). Since retention of voles requires that some slash be left on clear cut sites (Tevis 1956), this practice is suggested to accelerate recovery of clear cut areas. Further research in local management areas should test the interpretation that understory vegetation and some debris are sufficient to maintain high small mammal diversity in riparian clear cut zones.

#### LITERATURE CITED

- Cox, G. W. 1976. Laboratory manual of general ecology. 232 p. Wm. C. Brown Company Pub., Dubuque, Iowa.
- Gashwiler, J. S. 1970. Plant and mammal changes on a clearcut in West-Central Oregon. Ecology 51 (6):1018-1026.
- Kirkland, G. L., Jr. 1977. Responses of small mammals to the clearcutting of northern Appalachian forests. J. of Mamm. 58(2):600-609.
- Krebs, C. J. 1985. Ecology: The experimental analysis of distribution and abundance. Third edition. Harper and Row, Pub., New York.
- Maser, C., J. M. Trappe, and R. A. Nussbaum. 1978. Fungal-small mammal interrelationships with emphasis on Oregon coniferous forests. Ecology 59(4):799-809.
- Munz, P. A. 1973. A California flora with supplement. (in collaboration with D. D. Keck) University of California Press, Berkeley.
- Ramirez, P., Jr. and M. Hornocker. 1981. Small mammal populations in different-age clearcuts in Northwestern Montana. J. of Mamm. 62(2):400-403.
- Sokal, R. R. and F. J. Rohlf. 1981. Biometry: The principles and practice of statistics in biological research. Second edition. W. H. Freeman and Company, San Francisco.
- Tevis, L., Jr. 1956. Responses of small mammal populations to logging of Douglas-fir. J. of Mamm. 37(1):189-196.

# Riparian Area Management in the Pacific Southwest Region, USDA Forest Service<sup>1</sup>

Ivars J. Steinblums<sup>2</sup>

Andrew A. Leven<sup>3</sup>

---

Abstract.--This paper summarizes the USDA Forest Service (FS) direction regarding the management of riparian areas. It specifically focuses on the direction developed in the Pacific Southwest (PSW) Region of the FS.

---

## HISTORY OF NATIONAL AND REGIONAL DIRECTION

### Introduction

The USDA Forest Service has recognized the unique management requirements of riparian areas for many years. The Organic Administration Act of 1897 was the forerunner in establishing an environmental management precedent in the language "No National Forest shall be established, except to improve and protect the forest within the boundaries, or for the purpose of securing favorable conditions of water flows, and to furnish a continuous supply of timber for the use and necessities of citizens of the United States."

The management of riparian ecosystems, with respect to both natural and management induced benefits and effects, is fascinating. It is important to recognize that the potential of man's activities to shape and modify the landscape is small when compared with that of nature. As an integral part of the management of the National Forests, the FS takes into account the effect of natural physical and climatic forces on riparian ecosystems. Management is tailored towards protecting the riparian ecosystem during planning the conduct of management activities and evaluating what mitigation measures can be taken following natural catastrophic events, such as flooding,

wildfire, or severe windthrow.

### National Direction

Nearly seven decades after the Organic Administration Act was passed, the Multiple Use-Sustained Yield Act of 1960 reaffirmed a conviction to a quality environment in stating: "...harmonious and coordinated management of various resources, each with the other, without impairment of the productivity of the land, with consideration being given to the relative values of the various resources...." The National Environmental Policy Act (NEPA) of 1969 was legislation that directly emphasized the environment by requiring Federal agencies to utilize a systematic interdisciplinary approach in planning and decision-making.

Planning for wise and judicious resource management was directed in the Forest and Rangeland Renewable Resources Planning Act of 1974, which was subsequently amended by the National Forest Management Act (NFMA) of 1976. NFMA states: "No management practices causing detrimental changes in water temperature or chemical composition, blockages of water courses, or deposits of sediment shall be permitted within these areas which seriously and adversely affect water conditions or fish habitat."

In April 1980, a national policy on riparian area management was issued by the FS (USDA Forest Service 1980). The language from NFMA was the foundation for this national policy. The policy states: "The FS shall manage riparian areas in relation to various legally mandated requirements, including, but not limited to those associated with floodplains, wetlands, water quality, dredged and fill material, endangered species, wild and scenic rivers and cultural resources. Riparian areas must be managed in the context of the environment in which they are located."

Current FS management allows for other

---

<sup>1</sup>Paper prepared for the poster session held during the Riparian Ecosystems and Their Management: Reconciling Conflicting Uses Conference. (University of Arizona, Tucson, Arizona, April 16-18, 1985).

<sup>2</sup>Ivars J. Steinblums, Hydrologist, Watershed Management Staff, Pacific Southwest Region, USDA Forest Service, San Francisco, Calif.

<sup>3</sup>Andrew A. Leven, Director, Watershed Management Staff, Pacific Southwest Region, USDA Forest Service, San Francisco, Calif.

resource uses and activities to occur within riparian areas to the extent they support or do not adversely affect the maintenance of riparian-dependent resources over other resources and activities when conflicts occur.

In July 1981, FS national policy and direction was published for the management of floodplains and wetlands, to implement the intent of Executive Orders 11988 (floodplain management) and 11990 (wetland management). The policy was revised in 1984 (USDA Forest Service 1984). The policy states: "The FS shall ensure that flood hazards, floodplain and wetland values, and all practicable alternatives to the conduct, support, or approval of an action that directly or indirectly affects a floodplain or that involves new construction in wetlands are fully considered as an integral part of the FS planning and decision-making processes."

#### Regional Processes and Direction

The following is a chronology of the derivation of riparian area management processes and direction in the PSW Region.

#### Water Influence Zones

In the early 1960's, "water influence zones" were used in multiple-use plans to designate streams of high recreational value, for uses such as fishing, scenic quality, and water sports-related recreational uses. The water influence zones received management direction aimed at protecting their recreational values.

In addition to the early water influence zone procedures, in 1966 the PSW Region developed a procedure to evaluate a stream channel's ability to accept the impact from uses such as timber harvesting. Streams were classified as either "resistant" or "non-resistant" to erosional processes accelerated by mechanical disturbance. If timber was to be harvested in the vicinity of a non-resistant stream, special clauses were placed in the timber sale contract to preclude or minimize the amount of direct mechanical disturbance to the streambed and banks.

#### Buffer Strips

The use of buffer strips, land areas adjacent to the stream channel, came into use in the early to mid-1970's for the purpose of providing protection to the stream channel. Resource management activities were permitted within the buffer strips, but were modified so as to ensure the integrity of the streambed, banks, and adjacent terrestrial zone.

#### Stream Classification.

In 1975, the PSW Region developed a stream classification system to allow land managers to tailor the level of stream protection to the stream values (USDA Forest Service 1985a). By

using this system, streams can be evaluated and then classified as to their value in terms of beneficial uses.

Each class establishes the relative importance or significance of a stream or stream segment, based on resource values and beneficial uses, to be considered in developing a detailed description of necessary stream protection measures. The stream classification system consists of four classes. Class I streams are highly significant perennial or intermittent streams that are important for fisheries, domestic water supplies, special scenic values, threatened or endangered plant and animal species, cultural resources, major water-oriented recreation, and/or have flows large enough to materially influence downstream water quality. On the other end of the spectrum, Class IV streams have minor significance in terms of fisheries, domestic water supplies, and other resource values.

Concurrently with the development of the buffer strip direction and stream classification system, fisheries and wildlife biologists in the PSW Regional Office began developing goals and objectives for managing the fish and wildlife values within riparian ecosystems. Their goal was to gain recognition and acceptance for the importance of riparian systems to fisheries and wildlife needs.

#### Best Management Practices

During 1978 and 1979, the PSW Region began the development of a non-point pollution abatement water quality plan, as specified in Section 208 of the Clean Water Act (PL 92-500). The planning focused on consolidating all existing direction for non-point source pollution abatement into specific best management practices (BMPs) for each functional area. The BMPs were completed in 1979, described in Water Quality Management for National Forest System Lands in California (USDA Forest Service 1979), and were approved by the Environmental Protection Agency (EPA) and the State of California Water Resources Control Board.

Twenty different BMPs relate to the management of riparian areas for protecting water quality. This was the first introduction of the term streamside management zone (SMZ) into a formal FS document. Much effort has gone into the implementation of BMPs in the PSW Region. Individuals in each resource are being trained in their use, and especially in the concept that water quality management is not a single resource responsibility, nor an entity unto itself. The quality of water is interrelated to the quality of the riparian ecosystem.

#### Streamside management zones

In late 1980, work was begun to develop new direction in the PSW Region for the management of SMZs and riparian areas, to supplement National FSM direction. Such direction was recently



completed (USDA Forest Service 1985a, 1985b) describing specific guidelines for the management of SMZs and riparian areas, by and large expanding on and replacing the buffer strip concept. The direction focuses on the fact that although general guidelines can be developed for a particular National Forest, each riparian area and streamside management zone must be recognized as having its own unique fingerprint, requiring the development of management guidelines on a site-specific basis.

#### Cumulative Watershed Effects

The PSW Region has been developing a methodology for the assessment of cumulative watershed effects (CWE). Cumulative off-site effects include all impacts on the beneficial uses of water that occur away from the locations of actual land use and are transmitted through the fluvial system. Effects can be either beneficial or adverse and result from the synergistic effects of multiple management activities within a watershed.

Cumulative off-site watershed effects may result from changes in peak stream flows, sedimentation rates, or combinations of the two that occur in response to management activities. For watersheds undergoing increasing levels of management, these changes initiate acceleration of adverse off-site impacts. Channel aggradation, streambank undercutting, increasing rates of inner gorge mass wasting, and changes in fish habitat may be indicators that the fluvial system is experiencing adverse CWEs. Professional judgement is important in evaluating the potential for CWEs within a watershed, especially for management activities conducted in the vicinity of sensitive areas such as streams and riparian areas.

#### Planning

In October 1980, the PSW Region began preparing a "Regional Guide" to implement NFMA. The Regional Guide is a vehicle for passing national resource production targets for forest commodities assigned to the region down to the individual National Forests.

Forest Land and Resource Management plans are prepared by individual forests to determine their capability to produce the assigned targets, thereby validating or adjusting the regional targets. Forest production capability is aggregated into a regional capability which in turn is aggregated into a national capability. This is the cyclic process through which the individual forests use site-specific information to adjust national targets that may affect riparian area management.

Each forest plan specifies direction for the management and protection of riparian areas. Where the extent and location of riparian areas on a forest are not known, due to a lack of inventory data, direction is commonly included

as forest-wide standards and guidelines. This ensures that riparian areas are considered and protected on a case-by-case basis during the conduct of project activities wherever they occur.

Where the riparian areas are known, they can be delineated as "management areas" for which geographic-specific direction is provided. During land allocation modeling, constraints can also be applied which limit the type, intensity, and extent of activities which can take place within riparian areas. Thus, protection is accomplished as part of the land use resource output decision process.

#### SUMMARY

The PSW Region of the FS has been formally implementing various intensities of management direction for protecting riparian areas since the mid-1960s. Prior to this date, riparian areas and streamside management zones were evaluated and managed based on the direction contained in the Organic Administration Act.

FS direction, developed on a national and regional level, provides for the maintenance and protection of riparian areas and streamside management zones for each resource management activity. When natural catastrophic events do occur, the situation is evaluated and feasible mitigation measures are implemented. The implementation of the direction depends on careful coordination throughout the EA process, as well as when each project is carried out in the field.

#### LITERATURE CITED

- Pacific Southwest Region, USDA Forest Service. 1979. Water quality management for National Forest System lands in California. USDA Forest Service, Pacific Southwest Region, San Francisco, Calif.
- USDA Forest Service. 1980. Riparian areas. Amendment 26, Forest Service Manual 2526. USDA Forest Service, Washington, D.C.
- USDA Forest Service. 1984. Analysis and evaluations for floodplain management and wetland protection. Amendment 40, Forest Service Manual 2527. USDA Forest Service, Washington, D.C.
- USDA Forest Service. 1985a. Stream Protection - Streamside Management Zones. R-5 Supplement 36, Forest Service Manual 2521. USDA Forest Service, San Francisco, Calif.
- USDA Forest Service. 1985b. Riparian Areas. R-5 Supplement 36, Forest Service Manual 2526. USDA Forest Service, San Francisco, Calif.

# Riparian Community Type Classification<sup>1</sup> in the Intermountain Region

Andrew P. Youngblood, Wayne G. Padgett, and Alma H. Winward<sup>2</sup>

---

Abstract.--Classification of riparian ecosystems in Idaho, Wyoming, and Utah into different community types, based upon similarities in floristic composition, provides a tool for resource management. Diagnostic keys that utilize conspicuous plant species provide for field identification. Environmental relationships, successional status, and management implications are discussed.

---

## INTRODUCTION

Riparian ecosystems in the mountainous portions of Idaho, Wyoming, and Utah often form relatively narrow transition zones between aquatic and terrestrial ecosystems. These riparian zones have often been overlooked, or considered minor inclusions of the larger terrestrial systems. Current National Forest policy requires the recognition of the unique values of riparian ecosystems, and emphasizes their protection, management, and improvement during the planning and implementation of land and resource management activities (Peterson 1983). Classification of the riparian ecosystem provides the resource manager a means of inventory and delineation and a tool for refining management.

The Ecology Program of the Intermountain Region, USDA Forest Service, initiated fieldwork in 1979 leading to the development of riparian ecosystem classifications. Classifications in progress or already completed include portions of the Boise and Payette (Mutz and Queiroz 1983), Challis and Sawtooth (Tuhy and Jensen 1982), Targhee, Bridger-Teton, and Caribou (Youngblood and others, in press), and Wasatch-Cache, Uinta, and Ashley National Forests (Youngblood and others, in prep.).

The objectives of riparian ecosystem

---

<sup>1</sup>Paper presented at the first North American riparian conference, Riparian Ecosystems and their Management: Reconciling Conflicting Uses. [Tucson, Arizona, April 16-18, 1985].

<sup>2</sup>Andrew P. Youngblood is Area Ecologist and Wayne G. Padgett is Range Conservationist for the USDA Forest Service, Intermountain Region, stationed at the Forestry Sciences Laboratory, Logan, Utah; Alma H. Winward is Regional Ecologist for the Intermountain Region, stationed at Ogden, Utah.

classification include:

- 1--contribution to a broad Intermountain Region ecosystem classification effort;
- 2--description of characteristic geographic, topographic, edaphic, and floristic features of each type;
- 3--description of probably successional trends for each type; and
- 4--description of resource values and management opportunities for each type.

## METHODS

Riparian communities are composed of plant species that require or tolerate free or unbound water. They are identified by a combination of soil characteristics and distinctive plant species composition that usually differ from upland plant communities. Communities for sampling were selected to reflect the apparent range of environmental and successional conditions of an area and the relative homogeneity of vegetation. Sample plots (50 m<sup>2</sup> in size) in riparian communities were established to avoid ecotones.

Data from sample plots included:

- canopy coverage of all vascular plant species, ocularly estimated;
- herbaceous standing crop (annual production);
- soil profile description for top meter;
- bedrock and geology;
- aspect, slope, relative position, and elevation;
- relationship to adjacent riparian and upland communities; and
- recent disturbances and successional relationships.

Within the last 6 years, over 1000 plots have been sampled in riparian communities in the mountainous portions of central and eastern Idaho, western Wyoming, and northern Utah. Fieldwork generally followed procedures developed

by Norton and others (1981) and refined by Tuhy and Jensen (1982).

Data analysis was designed to assist in the development of an efficient natural taxonomic classification of riparian communities. All field data were computer coded for vegetation and environmental analysis. Preliminary association tables (Mueller-Dombois and Ellenberg 1974) were created, using plot species and canopy coverage values. Tables were rearranged to group sample plots with floristic similarities. Cluster analysis, using the Bray-Curtis similarity coefficient (Romesburg and Marshall 1984) provided a somewhat objective mathematical grouping of sample plots, arranged as a dendrogram. Detrended correspondence analysis (Hill and Gauch 1980) is an ordination technique, and was used to derive inferences of relationships between sample plots and environmental gradients.

## RESULTS AND DISCUSSION

The results of the different data analysis techniques were combined to form final classification of sample plots. Groups represent riparian community types, which are defined as units of vegetation having similar floristic composition, regardless of successful status. Within the Intermountain Region, about 70 community types have been classified and described. Community types were named after the dominant overstory and dominant or most diagnostic undergrowth species. Thus, a community characterized by Salix wolfii in the overstory, and an undergrowth consisting of Carex aquatilis and various mosses, is identified and written as belonging to the SALIX WOLFII/CAREX AQUATILIS community type. Field identification of the community type is made through the use of dichotomous keys.

Final published reports for each different geographic area within the Intermountain Region, such as South Fork Salmon River, included keys, distribution maps, and complete community type descriptions. Type descriptions indicated characteristic vegetation, general soils features and taxonomy, successional status, and pertinent physical and environmental features. When possible, preliminary management implications were discussed.

Community type classifications are hierarchical in that community types may be aggregated upward into larger dominance groups which share common physiognomy or overstory composition. This level of stratification may be useful for broad regional planning. Within the Intermountain Region, our dominance groups were named after forest tree species, such as Populus angustifolia, Betula occidentalis, or Picea engelmannii; tall shrubs, such as Alnus incana, Cornus stolonifera, Salix geyeriana, or Salix boothii; low shrubs, such as Salix wolfii, Potentilla fruticosa, or Artemisia cana; or herbaceous species, such as Carex rostrata, Deschampsia cespitosa, or Veratrum californicum.

The overall goal of this classification effort was to develop types that are meaningful and useful to the resource manager who may be concerned with management practices and their consequences within the riparian ecosystem. Perhaps the most significant aspect of this work is its delineation of the riparian ecosystems within the mountainous portions of the Intermountain Region. Resource managers now have a tool for identifying, in a field situation, the existence or boundaries of the riparian zone and the ecotone between it and terrestrial communities.

Furthermore, the resource manager now has a tool for describing riparian resources and communicating concepts relating to riparian community types for a variety of users through a single common classification. The riparian community type classifications portray the diversity of communities, successional patterns, and site characteristics within the study areas; they provide a basis for continuing studies of successional relationships; and they provide an inventory of major plant species and insights into relative amplitudes of common riparian species. The riparian classifications provide a tool for refining grazing systems based on sensitivity of plant species and site-selection by livestock; they are being used to stratify wildlife habitat and determine wildlife habitat values; and they provide a framework for the study of streambank stability and fish habitat. Different community types may be used to refine prescribed fire plans. Finally, the classifications provide a framework for developing silvicultural prescriptions for various objectives.

## LITERATURE CITED

- Hill, M. O., and H. G. Gauch, Jr. 1980. Detrended correspondence analysis: an improved ordination technique. *Vegetatio* 42:47-58.
- Mueller-Dombois, D., and H. Ellenberg. 1974. *Aims and methods of vegetation ecology*. 547 p. John Wiley and Sons, New York.
- Mutz, K. M.; and J. Queiroz. 1983. *Riparian community classification for the Centennial Mountains and South Fork Salmon River, Idaho*. 170 p. Contract No. 53-84 MB-2-0048, Meiji Resource Consultants, Layton, Utah. Unpublished.
- Norton, B. E., J. Tuhy, and S. Jensen. 1981. *Riparian community classification for the Greys River, Wyoming*. 188 p. Department of Range Science, Utah State University, Logan, Utah. Unpublished.
- Peterson, R. M. 1983. *Riparian management on the National Forest System*. Fisheries 8:22-25.
- Romesburg, H. C., and K. Marshall. 1984. *User's manual for CLUSTAR/CLUSTID computer programs for hierarchical cluster analysis*. 89 p. Lifetime Learning Publs., Belmont, Calif.

Tuhy, J. S., and S. Jensen. 1982. Riparian classification for the Upper Salmon/Middle Fork Salmon Rivers, Idaho. 200 p. white Horse Associates, Smithfield, Utah. Unpublished.

Youngblood, A. P., W. G. Padgett, and A. H. Winward. In press. Riparian community type classification of eastern Idaho-western

Wyoming. USDA Forest Service R-4-Ecol-85-1. Intermountain Region, Ogden, Utah.

Youngblood, A. P., W. G. Padgett, and A. H. Winward. In prep. Riparian community type classification of northern Utah. USDA Forest Service, Intermountain Region, Ogden, Utah.

# Dormant Stub Planting Techniques<sup>1</sup>

John C. York<sup>2</sup>

---

Abstract.--Bank and levee stabilization was done by using dormant stubs of black willow and cottonwood along the toes of banks and levees. 3-6 inch logs, 6-7 feet long, planted into the water table, resulted in exceptionally good survival and first season growth. The original 2,000 feet of plantings have survived 3 minor and 1 major flood and have given survival protection to the levee they protect.

---

## INTRODUCTION

Severe streambank and channel erosion has occurred throughout Arizona since 1980. Heavy rains and higher than normal runoff have caused extensive damage to stream channels. Repair of damaged dikes and levees by rebuilding them was not adequate. Further protection was needed. By updating work done by the CCC near Safford, Arizona, in 1936, some very successful plantings have been made.

## METHODS

In March, 1980, the first of many successful plantings was made. A 2,000-foot long levee near Bylas, Arizona, was chosen. The water table was 3 feet from the surface at the toe of the levee. An apron was dozed along the toe. The trees were planted 6 feet apart and 3 feet deep.

Dormant logs, 3-6" diameter and 6 feet long, of Gooding's willow (*Salix goodingii* Ball) and Fremont cottonwood (*Populus fremontii* wats.) were planted. Giant reedgrass was planted to control toe erosion. The trees were planted for habitat and as barriers to bank cutting. (They were designed to catch brush and let water through.)

The dormant log cuttings of willow and cottonwood were planted as follows:

1. Logs were cut with a chain saw with angle cuts on the root or bottom end and flat cuts on the crown or top end. This helps to prevent planting the cuttings upside down. The cuttings were post-size: about 6-7 feet long and 3-6 inches in diameter.

---

<sup>1</sup>Paper presented at the Poster Session of the First North American Riparian Conference. [Tucson, Arizona, April 16-18, 1985].

<sup>2</sup>John C. York is the State Biologist for the USDA Soil Conservation Service, Phoenix, Ariz.

2. Twelve to fourteen inches of the bottom end were scored with a hand ax.

3. Cuttings were placed in barrels 1/2 full of water with the tops up. "Rootone F," a rooting hormone, was mixed in the water at 1 oz./35 gallons. Cuttings should be placed in water as soon as possible and hauled to the job site in water.

4. Cuttings were placed in holes, spaces around logs were filled with soil and tamped.

5. All cut surfaces above ground were sealed with white paraffin. (Tree paint is a better sealant.)

## RESULTS

All of the trees sprouted the first season, although 5% died when the water table receded. One hundred percent of the giant reedgrass rhizomes sprouted. Ninety-five percent survived the first season. Some of the cottonwood cuttings sprouted but dried out, split and resprouted at ground level. All cottonwoods died back to varying degrees. During the second season, the reedgrass grew well and the willows put on intense side branch growth.

## GENERAL COMMENTS

1. Level all areas on the contour prior to planting cuttings or rhizomes. This will prevent moisture stress on plants trying to establish if the water table fluctuates.

2. Plant all cuttings (logs) before buds appear or sap starts to rise. Stubs are very heavy and difficult to handle when the sap is up. Use three-year or older wood if early and middle summer temperatures are over 100° F. This will keep planting stock from drying and splitting.

3. Vary the wound sealant color according to temperature in the planting area. For instance, use black sealant if early warming of the growing tip is needed; use white sealant if early warming or too hot temperatures is a problem.

4. Dormant log cuttings are successful. The system opens up all kinds of possibilities. For instance, erosion control "jacks" can be made from dormant logs driven into the water table. Deflection panels or dikes made from planted dormant logs, rocks and wire consistent with engineering designs become living deflection dikes.

5. As long as the dormant logs are placed in the water table, they grow. Sand dune areas along rivers can be planted to trees if the water table is within 14 or so feet. Tall dormant cuttings can be used so that new growth is out of reach of livestock.

6. There are many species of trees and shrubs that will root this way. (Commercial willows, dogwoods, hawthorns, athel, etc.) The field is wide open for further trials and plantings.

7. Dormant log plantings using large, bark-covered stock drastically reduces wind, sun, sand abrasion and insect attacks on planted stock.

8. The most serious problems facing riparian area rehabilitation using this system are a lack of planting stock and beavers. Beavers can be thwarted by woven wire around each log. Planting stock may have to be produced by private enterprise. There is an opportunity for private enterprise as more of these plantings are made.

9. The Soil Conservation Service has successfully planted over 15,000 feet of levee protection to date. Results continue to be good.

# Model Riparian Habitat Protection Statute

Jon A. Kusler, Chairman  
Association of State Wetland Managers  
Chester, Vermont

## INTRODUCTION

This draft riparian habitat protection statute draws heavily upon regulatory and nonregulatory approaches tested in state wetland regulation, floodplain regulation, and shoreland zoning programs throughout the Nation. See Kusler, Regulating Sensitive Lands, Ballanger Publishing Company, 1981. These include the coastal wetland regulation programs adopted by 18 coastal states, the freshwater wetland regulation statutes adopted by 11 states, the floodplain zoning statutes adopted by 31 states, and the shoreland corridor zoning statutes adopted by 7 states.

The draft will be revised over the next year. Comments and suggestions are welcome.

The draft approach establishes a procedure for state standard-setting for local regulation of riparian uses with direct state regulation of inflow uses (as is already the case in most states) and certain other uses (as determined by the regulatory agency). The state regulates all uses until local units of government adopt and administer regulations consistent with state standards. The statute draws heavily upon a similar wetland protection statute prepared by the author for the U.S. Fish and Wildlife Service. See Kusler, Strengthening State Wetland Regulations, U.S. Fish and Wildlife Service, 1978.

This statute is designed primarily for the arid and semi-arid states of the West. With the exception of Washington and Oregon, none of these states have adopted regulatory programs for shoreland corridors or freshwater wetlands. Only eight states have adopted state level floodplain zoning laws--Washington, Oregon (as part of State planning), Arizona, Oklahoma, Iowa, Kansas and Colorado. Therefore, this statute would overlap very little with existing programs.

The cooperative state/local approach proposed in the draft has been widely applied in programs of other states. An alternative approach--exclusive state regulation rather than a cooperative state/local regulation insures greater expertise in processing permits and less susceptibility to development pressures. But it poses administrative and enforcement problems for a state agency located hundreds of miles from proposed development sites. A cooperative state/local approach has political advantages where local home rule traditions are strong. It facilitates administration and enforcement and encourages the integration on

riparian habitat protection efforts with local zoning, subdivision control and building code programs. This cooperative state/local approach builds upon the strengths of both state and local regulation while minimizing some of the weaknesses of each.

The statute establishes the following framework:

1. A designated state agency is authorized to study and map riparian habitat in cooperation with federal agencies and local units of government. Mapping is to be carried out on a priority basis based on special values and hazards, threats of development, and the willingness of local governments to make use of data.

2. The state agency is authorized to promulgate regulations for riparian habitat areas. Local governments are given the option to adopt their own regulations meeting minimum state standards. The agency directly regulates habitat areas until local governments adopt satisfactory regulations and such regulations are approved by the agency. Once approved, the local governments issue permits for most types of activities.

3. The state agency is directed to provide technical and educational assistance to local governments and to encourage and undertake riparian habitat enhancement and rehabilitation (in appropriate circumstances).

4. Tax incentives are provided to encourage landowner protection and enhancement of riparian habitat.

## TEXT

### Section 1: Title

This act may be cited as the Riparian Habitat Protection Act of (State Name).

### Section 2: Statement of Legislative Finding, Policy and Purposes

The riparian habitat (and watercourses) of the state of (State Name) are indispensable but fragile natural resources subject to flood, erosion, soil bearing capacity limitations and other hazards. In their natural state they serve multiple functions for wildlife, pollution control, storage and passage of flood water, aquifer recharge, erosion control, education, scientific study, open space and recreation.

Considerable acreage of these important natural resources has been lost, despoiled or impaired by draining, dredging, filling, excavating, building, pollution and other acts. Other riparian habitat is in jeopardy of being lost, despoiled or impaired by such acts. This threatens the public welfare.

It is the policy of this state to establish a coordinated and cooperative program to protect, enhance, and restore riparian habitat. More specific goals include:

1. Establishment of a riparian habitat protection policy for all public and private lands and waters throughout the state;
2. Formation of management guidelines for activities within the riparian habitat area;
3. Implementation of such a policy through regulations and coordinated actions by all state and federal agencies and local governments;
4. The encouragement of local government and private riparian habitat protection and restoration efforts.

It is the policy of this State to require that activities not requiring a riparian habitat location be located at upland sites and that practicable alternatives to water-dependent activities be applied. It is the policy to insure that activities which require a riparian habitat location:

1. Do not block flood flows or destroy flood storage, increase erosion, or destroy natural erosion controls;
2. Do not cause or exacerbate water pollution through direct discharge of pollutants; location of domestic waste disposal systems on unsuitable soils; dredging, unauthorized application of pesticides, herbicides, and algicides; disposal of solid wastes at inappropriate sites; creation of unstabilized fills, or the destruction of riparian habitat vegetation important to erosion control;
3. Do not cause nuisances or threaten safety due to location of structures in flood or erosion areas or on soils with inadequate structural bearing capacity.
4. Do not violate other local, State, and Federal statutes, rules, and regulations.

In addition, it is the policy to control activities in riparian habitat areas to protect and preserve their functions as:

1. Wildlife habitat for breeding, nesting, and feeding grounds and cover for many forms of mammals, reptiles, waterfowl, and shorebirds, including migratory birds and rare species;
2. Nutrient sources for aquatic food cycles;

3. Fish and shellfish spawning and feeding areas;
4. Recharge areas for ground water;
5. Flood conveyance and storage areas;
6. Sites for education and scientific research including outdoor biophysical laboratories, living classrooms and training areas;
7. Recreation areas for hunting, fishing, boating, hiking, bird watching, photography, camping and other uses; and
8. Open space areas that aesthetically enhance the community and benefit local property values.

It is the policy of this State that activities requiring hydrologic or habitat modification provide for mitigation or degradation of environmental quality and habitat losses. Such mitigation must include, but not be limited to, minimizing impacts and restoration or replacement of damaged resources.

### Section 3. Definitions

The following definitions shall apply through this statute:

"Local government" means any city, village, town, or county.

"Person" means any individual, group of individuals, association, firm, partnership, corporation, trust, estate, organization or legal entity of any kind, including municipal corporations, government agencies, or subdivisions thereof.

"Regulated activity" means any activity with an adverse impact on the riparian habitat area as herein defined including dredging, draining, filling, bulkheading, mining, drilling, or excavating or engaging in activities that directly or indirectly kill or materially damage riparian habitat flora or fauna or construction of any kind including but not limited to construction of piers, jetties, breakwaters and boat ramps.

"Riparian Habitat" is defined for the purpose of this statute to include a transitional zone between aquatic and terrestrial (upland) ecosystems which is usually capable of supporting or does support riparian vegetation. Such a zone includes lands (select one of the following):

- a. Within 250 feet? 300 feet? 500 feet? of rivers and streams as mapped on the \_\_\_\_\_;
- b. Vegetated or susceptible to vegetation by the following species:
  - (1)
  - (2)
  - (3) etc.



c. Within the 100-year floodplain as defined by maps of the federal Emergency Management Agency of the stated \_\_\_\_\_ Department of \_\_\_\_\_ and \_\_\_\_\_.

#### Section 4: Agency Powers

The (State Agency) is authorized to undertake the following activities to implement the purposes of this act:

a. Prepare more specific riparian habitat protection goals, guidelines, and plans for implementation to state agencies and local governments;

b. Prepare and distribute maps of riparian habitat;

c. Adopt regulations for regulated activities within the riparian habitat area;

d. Provide technical assistance to local governments, landowners, other agencies;

e. Cooperate with other federal, state, and local agencies, land trusts, universities, private landowners, and others to implement riparian protection policies;

f. Monitor loss and changes in riparian habitat;

g. Undertake and promote the enhancement and restoration of degraded riparian habitat;

h. Develop and disseminate educational materials;

i. Acquire partial or fee interest in riparian habitat by donation, devise, fee or easement acquisition;

j. Advise, consult and cooperate with other agencies of the State, the Federal government, other states and with persons and municipalities in the furtherance of this act;

k. For all activities that will impact fish and wildlife and their habitat, consult with the State Fish and Game Agency, and the U.S. Fish and Wildlife Service;

l. Encourage, participate in or conduct studies, investigations, research and demonstrations and collect and disseminate information relating to the purposes of this act.

#### Section 5: Mapping

1. The (State Agency) or its authorized representative shall, as soon as practical, make and periodically revise an inventory and maps of the riparian habitat of the state in cooperation with other State agencies, Federal agencies, and local units of government. Maps shall set forth boundaries of riparian habitat using photographic and cartographic standards and techniques as the (State Agency) may deem appropriate. Boundaries shall be capable of location on the ground either

by reference to the maps alone or in combination with field investigations to apply definition criteria. The (State Agency) may adopt interim maps for areas of special value or hazard or areas threatened by development until more detailed mapping is possible or practical.

2. The (State Agency) shall prepare a list of riparian habitat areas to be mapped and shall recommend the priorities in which studies shall be undertaken. The list shall be reviewed at least annually by the (State Agency). In establishing and revising the list, the (State Agency) shall consider: (a) degree of danger to lives and property from flooding, erosion, water pollution and other hazards; (b) the value of the habitats in serving the functions set out in section 2 of this act; (c) the rate and type of development taking place; (d) the ability and willingness of political subdivision(s) having jurisdiction over the area to make use of the data; and (e) other considerations pertinent to the situation.

3. Maps may be prepared separately for various regions of the State as the (State Agency) may determine.

#### Section 6: Local Government Roles

It is the intent of this legislation that local governments have a primary role in the protection and enhancement of riparian habitat and that standards for habitat protection enhancement and restoration be incorporated in local plans and regulations. Local governments are therefore authorized to adopt zoning, subdivision control, and other regulations necessary to carry out the purposes of this act pursuant to procedures established by (reference to zoning, subdivision control, other statutes).

Local wetland protection zoning, subdivision control and ordinances in effect prior to this statute shall be unaffected by the adoption of regulations by the (State Agency) to the extent that the local regulations equal or exceed in restrictiveness those of the (State Agency). Local governments are encouraged to adopt and enforce regulations equalling or exceeding those of the (State Agency) in restrictiveness and to assist the (State Agency) in administering and enforcing its regulations by cooperating in mapping, the adoption of rules and guidelines, the conduct of hearings on permits, the monitoring of riparian activities, and the enforcement of regulations.

2. If the (State Agency) finds that proposed or adopted local regulations meet or exceed minimum (State Agency) standards, the (State Agency) shall approve the proposed regulations within thirty days of their receipt. A local government may issue riparian habitat permits as specified in (State Agency) guidelines (See Section 7) after regulations have been approved.

3. The (State Agency) shall provide technical assistance to local governments in adopting and administering riparian habitat regulations. This

assistance may include draft ordinances, guide-books, pamphlets, workshops, assistance in evaluating individual permits, and other measures considered appropriate.

Local governments shall, within one year of adoption of minimum guidelines for local regulated activities by the (State Agency), adopt local zoning, subdivision, or other ordinances to implement such guidelines. Such regulation shall be submitted to the (State Agency) for approval as complying with (State Agency) guidelines. Once certified, permits for specified activities shall be issued by the local governments. In the event local governments fail to adopt and submit for approval such local regulations within one year, the (State Agency) shall charge the local government for such administration of regulations within the riparian areas of that local government until such local government adopts and administers regulations meeting minimum state standards.

#### Section 7: Permit Requirements

After the effective date of adoption of regulatory guidelines by (State Agency), all persons desiring to undertake a regulated activity within the riparian habitat area shall first obtain a permit from (State Agency) or a local government with an approved program.

Such permits shall be issued only if the activity is in compliance with other applicable state, federal, and local regulations, and with guidelines adopted by (State Agency) or an approved local government. The Agency or approved local government may charge reasonable fees for such permits.

Such permits shall be valid for a period of time specified by the (State Agency) or local government and may be revoked for failure to comply with regulatory guidelines, including conditions attached to the permit.

#### Section 8: Standards for Regulated Activities

The (State Agency) shall, within six months of the adoption of this act, promulgate minimum standards for regulated activities within riparian habitat areas, and for local regulatory programs. Such standards may include (but are not limited to):

1. Minimum setbacks and buffers;
2. Density restrictions and minimum lot sizes.
3. Restrictions on tree-cutting and other vegetation removal;
4. Guidelines for flood loss reduction and storm water management;
5. Special restrictions for habitat of rare and endangered species;

6. Performance standards for regulated activities;

7. Guidelines and procedures for assessing the cumulative impact of uses and minimizing such impact;

8. Conditions which may be attached to permits for mitigation of impacts including restoration and enhancement.

In promulgating such standards, the (State Agency) may classify riparian habitat and activities by type, size, or other factors relevant to advancement of the goals of this act.

#### Section 9: Enhancement and Restoration

The (State Agency) shall prepare plans and policies for rehabilitation and restoration of degraded riparian habitat. Such plans and policies shall consider the existing and potential value of various sites and shall establish priorities for restoration and restoration. Such plans may be prepared in cooperation with landowners, local governments, and other agencies.

The (State Agency) may initiate restoration and enhancement activities pursuant to such plans including but not limited to revegetation, restocking, fencing, irrigation and other measures. Such restoration and enhancement activities may be undertaken in cooperation with private landowners, corporations, land trusts, other state and federal agencies, local governments and other interested individuals or entities.

The (State Agency) or any local government may enter into a cooperative agreement with an owner of riparian habitat for the purpose of restoring or rehabilitating such habitat in accordance with the policies of this statute. Such a cooperative agreement shall provide that the habitat be enhanced and/or restored. Such agreement shall be effective in perpetuity or for a length of time specified in the agreement. Payments may be made by the (State Agency) local government for such agreements. In addition, ad valorem taxes shall reflect the cooperative agreement as provided in Section 11.

The (State Agency) may disperse funds appropriated for restoration and enhancement by section to any local government entering into a cooperative agreement with a landowner or directly to such landowner pursuant to an agreement.

#### Section 10: Tax

Any owner of riparian habitat who may be denied a permit for a regulated activity shall, upon written application to the assessor, or board of assessors of the (Local Government) be entitled to reevaluation of such property to reflect the fair market value thereof in light of the restriction placed on the land by the demand of such permit, provided no such revaluation shall be effective retroactively.

Such reevaluation shall also be available to any owner for land under a conservation restriction or, cooperative agreement (Section 9) effective the date of the restriction or cooperative agreement.

#### Section 11: Judicial Appeal

Any person aggrieved by any regulation, decision or action made pursuant to this act may appeal to (Court) within thirty days of that decision or action.

#### Section 12: Penalties and Enforcement

Any person who commits, takes part in, or assists in any violation of any provision of this act including regulations promulgated by the (State Agency) is guilty of a (Felony, Misdemeanor) and may be fined up to \_\_\_\_\_ dollars for each offense and subject to imprisonment not exceeding three months or both. Each violation of this act shall be a separate offense, and, in the case of continuing violations, each day's continuance thereof shall be deemed to be a separate and distinct offense.

Permits may be terminated for cause including violation of permit conditions, obtaining a permit by misrepresentation, or failing to disclose relevant fact, or change in conditions.

The (State Agency) shall have jurisdiction to issue orders directing that any violation of this act be corrected or removed. All costs, fees and expenses in connection with such action shall be assessed as damages against the violator. It shall also have the power to seek court injunctions to enforce these orders.

In the event of a violation, the (State Agency) shall have the power to order complete restoration of the riparian habitat area involved by the person or agent responsible for the violation or other compensation where restoration is not feasible and seek court injunctions to require compliance with their orders. If such responsible person or agent does not complete such restoration within a reasonable time following the order, the (State Agency) shall have the authority to restore the affected riparian habitat to its prior condition wherever possible and the person or agent responsible for the original violation shall be held liable to the (State Agency) for the cost of restoration.

Any penalty assessed pursuant to this statute including costs of wetland restoration and any restoration requirements shall be recorded in the clerk of courts as a lien against the land and shall not be removed until the penalty is paid or restoration is completed.

All State, county, and local law enforcement officers and citizens are directed to be watchful for violations of the provisions of this chapter and to report all suspected violations to the (State Agency).

The attorney general of the State, a district attorney having jurisdiction, or a public attorney

of a local unit having jurisdiction may initiate enforcement actions as described herein against any person or persons believed to be in violation of this statute.

#### Section 13: Appropriations

The legislature of the State of \_\_\_\_\_ appropriates the sum of \_\_\_\_\_ for the administration of this statute including the sum of \_\_\_\_\_ for restoration and enhancement and a cooperative agreement pursuant to Section 9 of this statute.

#### COMMENTARY ON DRAFT STATUTE

#### Section 2: Statement of Legislative Finding, Policy, and Purposes

The statement of legislative finding, policy, and purposes is self-explanatory in most respects.

1. The section emphasizes riparian habitat flood, erosion, and other hazards as well as habitat values. This strengthens the legal basis for regulations and links habitat protection with broader flood plain regulation efforts.

2. Mitigation of impact is required where activities require a riparian habitat location.

3. Riparian habitat restoration as well as protection is emphasized.

#### Section 3: Definitions

This section contains a minimum list of definitions. A State may wish to expand the list.

The term "authorized local unit of government" is defined to include villages, towns, cities, and counties. States may wish to modify this definition. There are important advantages to regulations by counties or other local units with large geographical size since greater control can be gained over the wetland watershed and the task of coordinating State and local activities is simplified.

The term "riparian habitat" is first defined in the draft statute with three options (selection is left to the state)

Fixed corridors. The "shoreland" zoning statutes of Wisconsin, Minnesota and Michigan define, by statute, a 1000 foot corridor around lakes and ponds and a 300 foot corridor along each side of a stream or the landward side of the floodplain if this distance is greater. Such a fixed corridor has been easy to define on the ground but does not necessarily reflect vegetation, soils, flooding or other characteristics at particular sites.

The second approach--vegetation lists--has been extensively applied in freshwater and coastal wetland protection statutes in the eastern states and has proved quite satisfactory except where vegetation has been destroyed. Maps are needed with this approach.

The third approach--flooding--has been extensively used in the state floodplain zoning efforts in 31 states. Flood maps indicating the limits of a 100 year flood are available for much of the Nation, including the arid and semi-arid west and form the basis for floodplain zoning by more than 17,000 communities across the Nation. Flooding does not, of course, necessarily coincide with vegetation.

Some combination of approaches might also be applied. For example, the riparian habitat zone might be defined to include a 300 foot strip or to the landward side of the 100 year floodplain--an approach taken in the Wisconsin and Minnesota shoreland zoning statutes.

The term "regulated activity" is broadly defined here to include virtually all types of activities which may threaten riparian habitat. A more restrictive definition could exclude or "grandfather" certain ongoing activities.

#### Section 4: Agency Powers

This section authorizes an Agency to develop a program for protection and management of the State's riparian habitat. A State may best designate an existing resource agency such as a department of natural resources, fish and wildlife agency or water resources agency as the riparian habitat management and regulatory agency. It can then tap existing manpower, data, and, in some instances, budgets. However, a creation of a new agency or board may also have advantages, including a clear independent mission.

Many of the agency functions set forth in this section, including habitat inventory, adoption of rules for habitat and evaluation of permit applications, are developed in greater detail in later sections of the statute. It should be noted that acquisition as well as regulatory powers are provided. A State may wish to cross-reference these provisions with statutes now in existence that authorize a department of natural resources or another conservation agency to condemn or otherwise acquire lands.

#### Section 5: Mapping

This section directs the agency to inventory and map habitat. Mapping on an interim or more permanent basis is important to the operation of the act since landowners are often uncertain as to whether or not they require a permit until areas have been mapped. Experience indicates that it is often difficult to administer and enforce regulations until maps are available.

One map scale may be appropriate for an urban area and another for a rural area. It should be noted that boundaries shall be "capable of location on the ground either with reference to the maps or in combination with field investigations to apply definition." This permits refinement of boundary lines on a case-by-case basis.

The Agency is directed to map areas on a priority basis. Such an approach has been

followed in states with existing wetland statutes. States may receive technical assistance and maps from the U.S. Fish and Wildlife Service's National Wetland Inventory project to aid them in their efforts.

#### Section 6: Local Government Roles

This section authorizes and requires local units to adopt riparian habitat regulations. The legislature must, of course, decide which local units are to be responsible. Most local units are delegated sufficient power to adopt habitat regulations under zoning, subdivision control, or special critical area enabling acts. The section resolves doubts concerning enabling authority.

#### Sections 7 and 8: Permit Requirements; Standards for Regulated Activities

These sections contemplate several types of permitted activities: those regulated exclusively at State level, those regulated cooperatively by the State and localities where localities adopt regulations meeting minimum State standards and submit permit applications to the State for review, and those regulated exclusively at the local level. It is anticipated that only a small number of activities with significant wetland impact would be regulated exclusively at the State level. The majority of activities would be regulated cooperatively by the State and local governments or at the local level.

The present draft statute authorized the State regulatory board or agency to determine activities which would be subject to State, cooperative State/local or local permits.

The larger or most important activities requiring exclusive State approval might include power generation plans, dams, and major fills where local units lack the expertise or geographical perspective for effective regulation or where State or Federal law preempts local regulation.

To permit such a hierarchy, the State regulatory board or agency is directed to establish minimum guidelines for local regulation of activities. Direct State regulation continues if local units fail to adopt and enforce adequate regulations. Such an approach has been used in the wetland programs of Connecticut and New York and is used very widely in floodplain, shoreland, and coastal area efforts. Minimum standards for local regulations are incorporated in agency administrative regulations. The agency is also to specify activities which will require agency review prior to issuance of a local permit. Activities requiring only local approval might include activities such as minor drainage projects.

#### Section 9: Enhancement and Restoration

The State Agency is authorized to establish policies and plans for the enhancement and restoration of riparian habitat in cooperation with landowners, land trusts, local governments and other parties. It is also authorized to carry out such restoration directly or through cooperative

agreements. Such restoration and enhancement could take place for existing degraded habitat, in conjunction with a permit violation, or in conjunction with a permit issuance.

#### Tax

A number of states including New York and Massachusetts have included tax incentive provisions resembling the one here in their wetland regulation statutes. A second approach--a state income tax credit--has been adopted in the Minnesota wetland protection statute and in a riparian habitat protection statute adopted in Oregon.

#### Section 10: Judicial Appeal

Appeal is provided for from any action of a local unit or the regulatory body to a court speci-

fied by the legislature. This may include a local court with jurisdiction at the site of a proposed permit or action or, alternatively, a court located at the site of headquarters of the agency or board. A State may wish to reference an existing administrative appeal statute or establish more specific standards and criteria for appeal.

#### Section 11: Penalties and Enforcement

This section provides penalties for violation of regulation, including fines and jail sentences. The regulatory agency may also order restoration of the wetland by the violator and seek court enforcement of such an order. It may undertake restoration and charge the violator in the event of non-compliance with the restoration order. Penalties are to be recorded as a lien against the land and shall not be removed until the penalty is, or the restoration completed.

## Author Index

Abido, Mohammad S.	467	Field, Donald R.	227
Adams, Karen R.	485	Field, Ronald J.	23, 265
Aguirre, Raymundo	475	Finch, Deborah M.	495
Aitkin, J. Kevin	359	Fogel, Martin N.	384
Allen, Roosevelt T.	23, 265	Foster, David	393
Allen, Stewart	426	Fox, Carl A.	87
Andersen, Douglas C.	216	Frye, Carrie B.	325
Anderson, Bertin W.	117, 123, 128	Garcia, John C.	335
Anderson, Mark T.	364	Garman, Greg C.	315
Anderson, Mike W.	433	Gatz, Thomas A.	355
Anderson, L. Susan	150	Gay, Lloyd W.	171
Anderson, Stanley H.	300	Gebhardt, Karl A.	30
Apple, Larry L.	489	Gibbons, Dave R.	320
Babbitt, Bruce	Foreword	Glinski, Patricia Conley	342
Bachant, Joseph P.	443	Goertler, Chris M.	325
Barclay, John S.	62, 456	Grate, D. L.	166
Bayha, Keith D.	491	Greenlee, Daniel	175
Behrens-Tepper, Jean C.	216	Griepentrog, Thomas E.	44
Belfit, Scott C.	359	Groeneveld, David P.	44, 166
Black, S.	413	Haight, Lois T.	156
Bojorquez, Luis	475	Hardy, Rodd V.	371
Bock, Jane H.	493	Harris, Richard R.	87
Bock, Carl E.	493	Haugen, Gordon N.	21
Bouwer, Herman	191	Heede, Burchard H.	54
Brady, Ward	39	Hightower, J.	413
Branson, Farrel A.	197	Hill, David P.	398
Broadhurst, P.	413	Hoar, Alexander R.	250
Brock, John H.	49	Hoover, Sharon L.	223
Brown, Bryan T.	76	Hubbard, P. J.	166
Brown, David L.	175	Hubert, Wayne A.	290
Bryant, Larry D.	285	Hunter, William C.	117, 128
Bryant, Mason D.	329	Huntley, Jimmy C.	263
Buckhouse, John C.	369	Huser, Verne L.	439
Caballero-Deloya, Miguel	9	Jackson, William L.	30
Casey, Osborne	67	Jakle, Martin D.	355
Ceballos-G., Gerardo	96	Jayne, Jo Ann B.	479
Chilman, Kenneth C.	393	Jemison, Roy L.	470
Christensen, Kerry M.	101	Johnson, Lee D.	502
Corbett, Edward S.	187	Johnson, R. Roy	76, 112, 156
Cox, Jerry R.	305	Jones, K. Bruce	342
Cross, Stephen P.	269	Kelly, Tim	403
Crumpacker, David W.	3, 389	King, David A.	223
Cuplin, Paul	67, 69	Kingsley, Kenneth J.	245
Dawson, Kerry J.	408	Knopf, Fritz L.	105
DeBano, Leonard F.	211	Krausman, Paul R.	144
Dickson, James G.	263	Krueger, Henry O.	300
Dileanis, Peter D.	197	Kusler, Jon	6
Dodd, J. L.	276, 374	Lambou, Victor W.	180
Duell, Lowell F. W. Jr.	161	Lanka, Robert P.	290
Elder, Robert G.	35, 379	Lee, L. C.	139, 499
Erwin, Michael J.	250	Lee, Martha E.	227
Everson, Alan	393	Leopold, Bruce D.	144
Fannin, Timothy E.	201	Leven, Andrew A.	507
Fedock, Donald A.	498	Loeks, C. David	13
Ffolliott, Peter F.	384, 470	Lowe, Charles H.	112, 339

Lowrance, Richard	237	Shah, Bashir H.	482
Lynch, James A.	187	Sharitz, R. R.	139, 499
Mantell, Michael	421	Shirmohammadi, Adel	237
Maret, Timothy J.	201	Short, Henry L.	257
Marlow, Clayton B.	279	Siekert, Ronald E.	276
Martinson, Kristen	227	Simons, Lee H.	505
Masinton, Roy	67	Simms, Bruce D.	502
Matter, William J.	223	Skau, C. M.	175
Metzger, Philip	421	Skinner, Q. D.	276, 374
Meyer, Philip A.	1, 417	Smith, Bruce H.	35, 371
Moore, Richard C.	379	Smith, M. A.	276, 374
Moring, John R.	315	Sorenson, Stephen K.	197
Morton, Howard L.	305	Sorooshian, Soroosh	191
Mullen, Dennis M.	315	Spear, Michael J.	27
Mullins, Charles L.	135	Stabler, D. Frederick	206, 290
Munk, D.S.	166	Steinblums, Ivars T.	507
Nabhan, Gary Paul	232	Stevens, Lawrence E.	81
Nork, Diane M.	161	Stuber, Robert J.	310
Novak, P. J.	166	Sutter, Gregory E.	408
Ohmart, Robert D.	117, 123, 128	Swank, Gerald W.	435
O'Leary, Joseph T.	216	Sweep, Donald H.	371
Ortega, Alfredo	475	Swenson, Edwin A.	135
Padgett, Wayne G.	510	Szaro, Robert C.	211, 359
Parker, Michael	35, 201	Taylor, Thomas J.	62
Patton, David R.	39	Thames, John L.	482
Paxson, Jay	39	Thomas, John R.	72
Platts, William S.	30, 67	Tillemans, B.	166
Pogacnik, Thomas M.	279	Vanderheyden, Jon	448
Rautenstrauch, Kurt R.	144	Waring, Gwendolyn L.	81
Reid, Christine	421	Warren, D. C.	166
Rhodes, Jonathan	175	Warren, Peter L.	150, 347
Richards, Merton T.	219	Wegner, David L.	453
Rinne, John H.	295, 359	Wehnes, Richard E.	443
Risser, Roland J.	87	Wesche, Thomas A.	290, 325
Ritzi, Robert W.	191	Wilcox, Glenn I.	59
Rodgers, J. D.	276, 374	Winward, Alma H.	510
Roseboom, Donald	241	Wood, D. Brent	219
Rosgen, David L.	91	Wood, Fred Jr.	35
Ruffner, George A.	498	Yamashita, I.	166
Russell, Kenneth	241	York, John C.	513
Schauman, S.	413	Youngblood, Andrew P.	510
Schultze, Ronald F.	59	Zauderer, Jeffrey	463
Schwalbe, Cecil R.	347	Zilincar, J. M.	371





Johnson, R. Roy; Ziebell, Charles D.; Patton, David R.; Ffolliott, Peter F.; Hamre, R. H., tech. coords. Riparian ecosystems and their management: reconciling conflicting uses. First North American riparian conference; 1985 April 16-18; Tucson, AZ. Gen. Tech. Rep. RM-120. Fort Collins, CO: U.S. Department of Agriculture, Forest Service, Rocky Mountain Forest and Range Experiment Station; 1985. 523p.

These proceedings include 105 papers and 12 poster presentations. Primary topics include: physical characteristics, hydrology, and ecology of riparian ecosystems; riparian resources: recreation, agriculture, wildlife, livestock use, fisheries, and amphibians and reptiles; multiple-use planning and management; legal and institutional needs; and riparian ecosystems in dryland zones of the world. A model Riparian Habitat Protection Statute is appended.

Keywords: Riparian habitats, endangered habitats, aquatic ecosystems.

Johnson, R. Roy; Ziebell, Charles D.; Patton, David R.; Ffolliott, Peter F.; Hamre, R. H., tech. coords. Riparian ecosystems and their management: reconciling conflicting uses. First North American riparian conference; 1985 April 16-18; Tucson, AZ. Gen. Tech. Rep. RM-120. Fort Collins, CO: U.S. Department of Agriculture, Forest Service, Rocky Mountain Forest and Range Experiment Station; 1985. 523p.

These proceedings include 105 papers and 12 poster presentations. Primary topics include: physical characteristics, hydrology, and ecology of riparian ecosystems; riparian resources: recreation, agriculture, wildlife, livestock use, fisheries, and amphibians and reptiles; multiple-use planning and management; legal and institutional needs; and riparian ecosystems in dryland zones of the world. A model Riparian Habitat Protection Statute is appended.

Keywords: Riparian habitats, endangered habitats, aquatic ecosystems.

Johnson, R. Roy; Ziebell, Charles D.; Patton, David R.; Ffolliott, Peter F.; Hamre, R. H., tech. coords. Riparian ecosystems and their management: reconciling conflicting uses. First North American riparian conference; 1985 April 16-18; Tucson, AZ. Gen. Tech. Rep. RM-120. Fort Collins, CO: U.S. Department of Agriculture, Forest Service, Rocky Mountain Forest and Range Experiment Station; 1985. 523p.

These proceedings include 105 papers and 12 poster presentations. Primary topics include: physical characteristics, hydrology, and ecology of riparian ecosystems; riparian resources: recreation, agriculture, wildlife, livestock use, fisheries, and amphibians and reptiles; multiple-use planning and management; legal and institutional needs; and riparian ecosystems in dryland zones of the world. A model Riparian Habitat Protection Statute is appended.

Keywords: Riparian habitats, endangered habitats, aquatic ecosystems.

Johnson, R. Roy; Ziebell, Charles D.; Patton, David R.; Ffolliott, Peter F.; Hamre, R. H., tech. coords. Riparian ecosystems and their management: reconciling conflicting uses. First North American riparian conference; 1985 April 16-18; Tucson, AZ. Gen. Tech. Rep. RM-120. Fort Collins, CO: U.S. Department of Agriculture, Forest Service, Rocky Mountain Forest and Range Experiment Station; 1985. 523p.

These proceedings include 105 papers and 12 poster presentations. Primary topics include: physical characteristics, hydrology, and ecology of riparian ecosystems; riparian resources: recreation, agriculture, wildlife, livestock use, fisheries, and amphibians and reptiles; multiple-use planning and management; legal and institutional needs; and riparian ecosystems in dryland zones of the world. A model Riparian Habitat Protection Statute is appended.

Keywords: Riparian habitats, endangered habitats, aquatic ecosystems.

