



THE SAMUEL ROBERTS
NOBLE
FOUNDATION

“The land must
continue to provide
for our food,
clothing and shelter,
long after the oil is
gone ...”

- Lloyd Noble



70TH
ANNIVERSARY
EST. 1945
THE SAMUEL ROBERTS
NOBLE
FOUNDATION



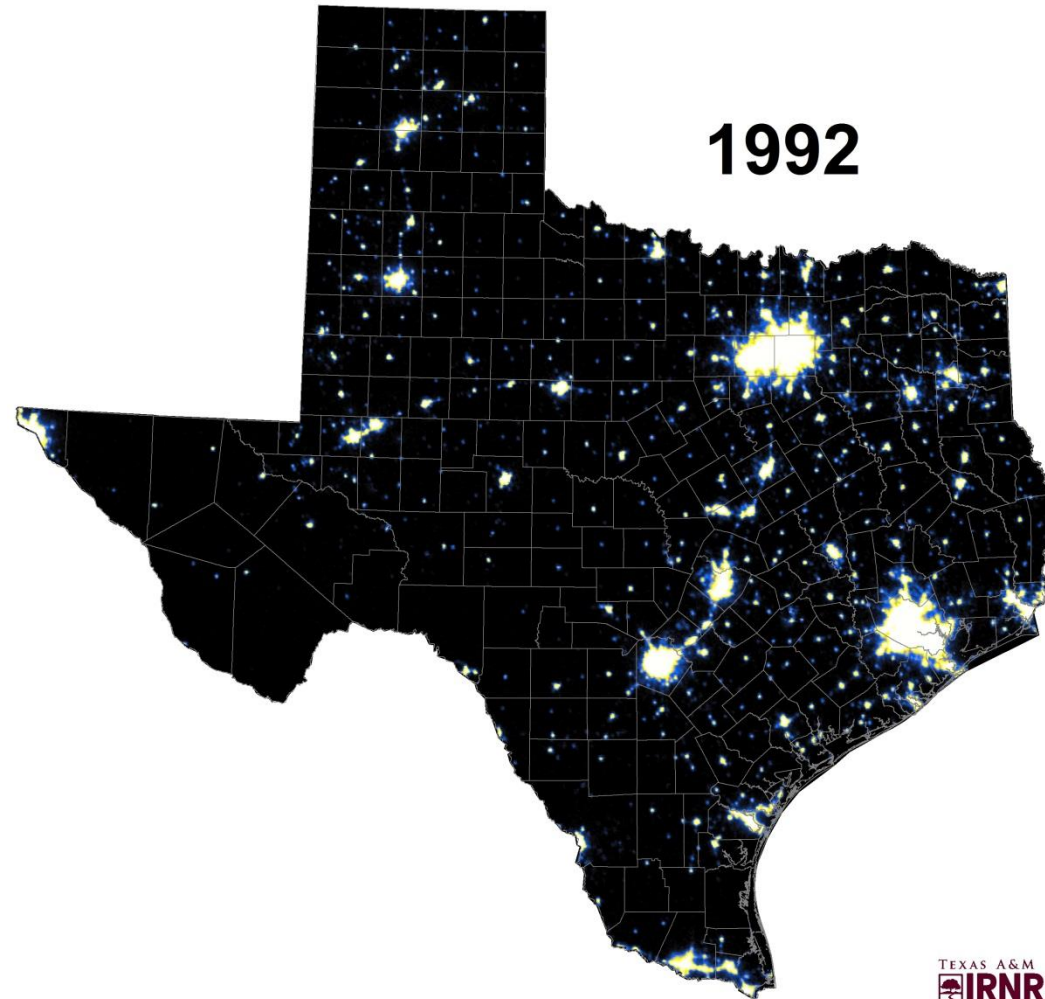


THE SAMUEL ROBERTS
NOBLE
FOUNDATION

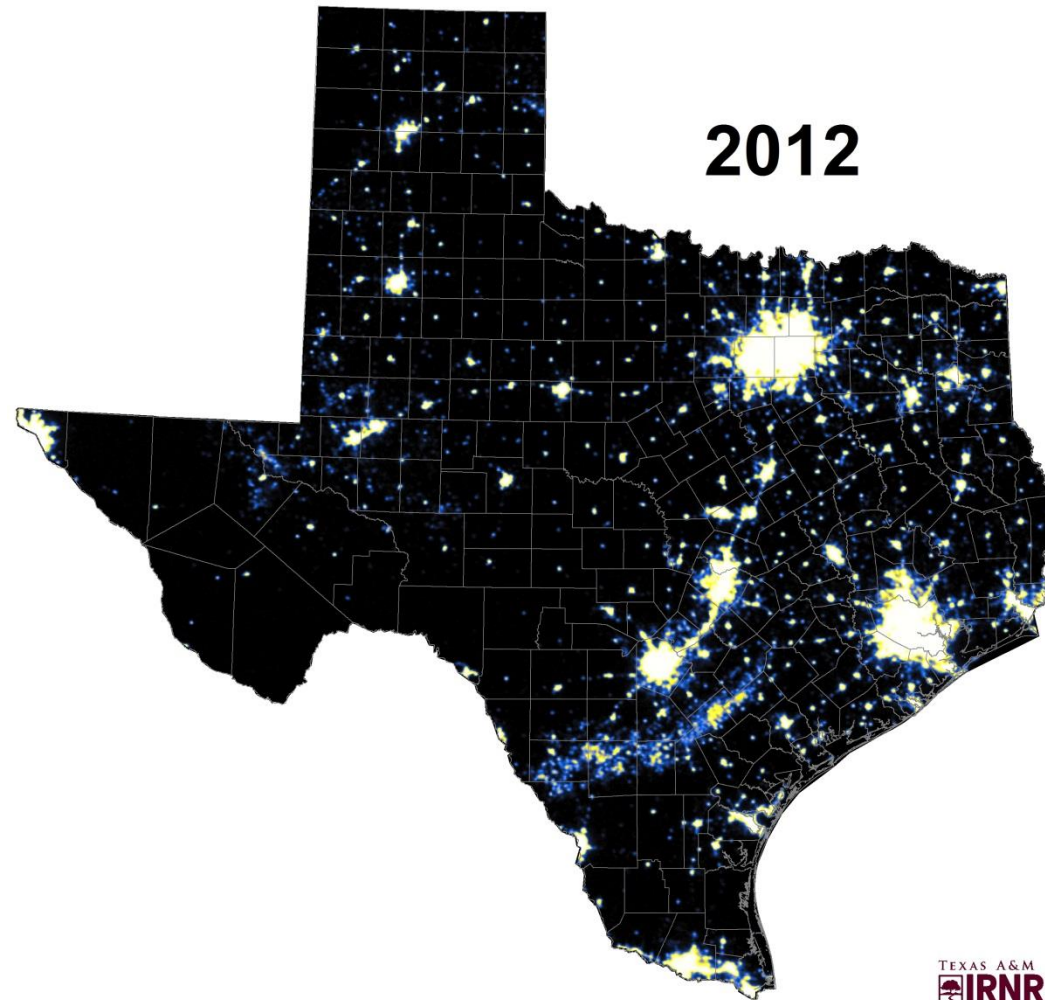
Mission Statement

The purpose of The Samuel Roberts Noble Foundation is to **advance agricultural science** and practice by conducting **field and laboratory research**, and by **providing consultation** to farmers, ranchers and land managers in the Southern Great Plains. Through its operations, the organization is committed to **conserving and improving the soil**, and **fostering sustainable agricultural practices**. In the philanthropic spirit of Lloyd Noble, the Noble Foundation also supports worthy charities through a program of grants with the aim of building stronger communities.

Statewide Night Time Illumination



Statewide Night Time Illumination



Statewide Ownership Size

- Increase (500K+ acres) of <100 acre farms
- Decrease (4M acres) of 100-2000 acre farms
- Increase (400K acres) of >2000 acre farms

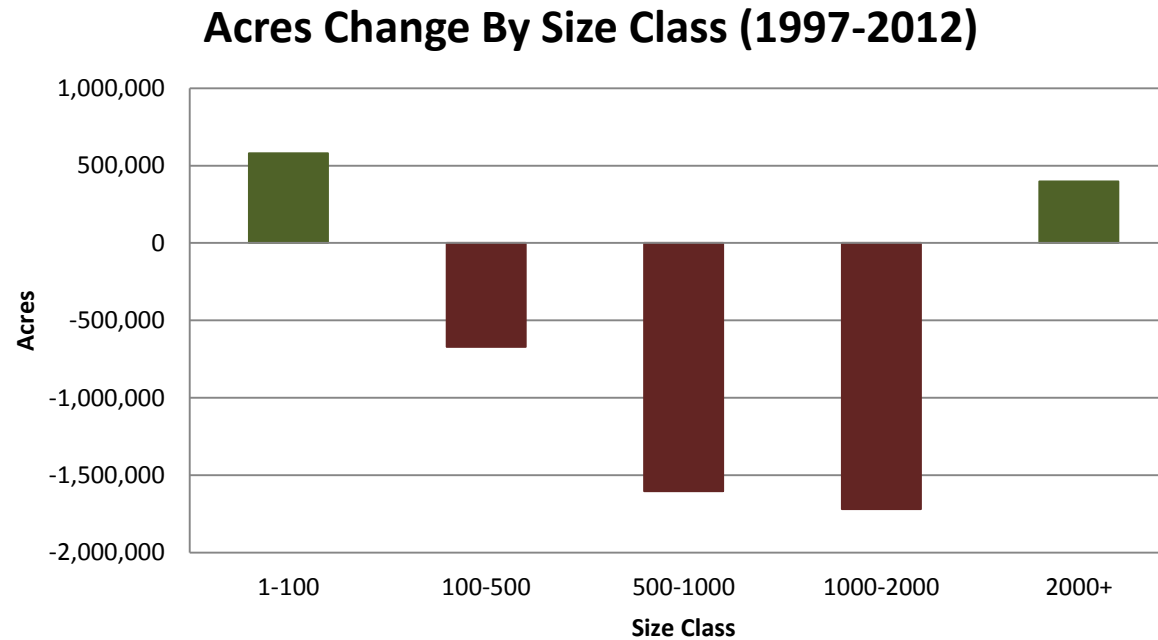
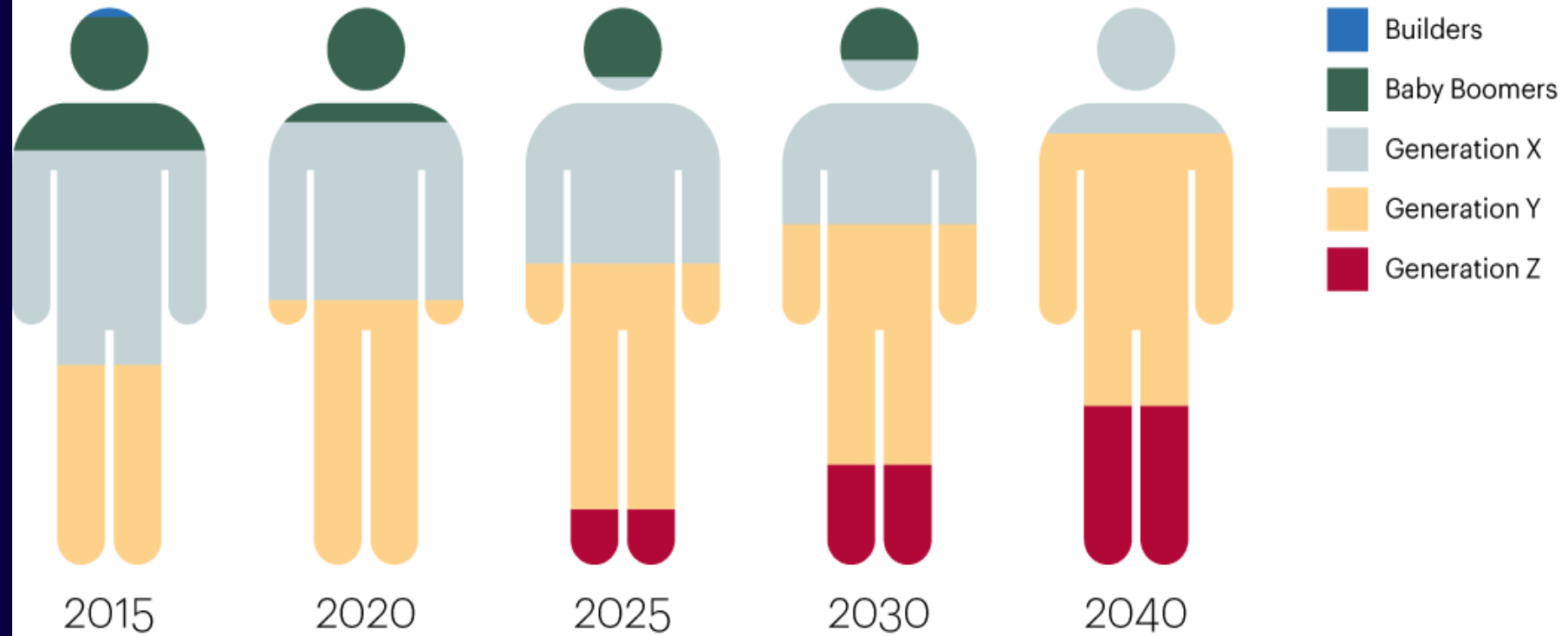


Figure 1

Millennials will comprise the majority of the workforce by 2025



Source: U.S. Census Bureau

Gender Matters for Generation Y— www.atkearney.com



National Photo Archive



Per Gocoshe
<https://www.flickr.com/photos/peronimo>

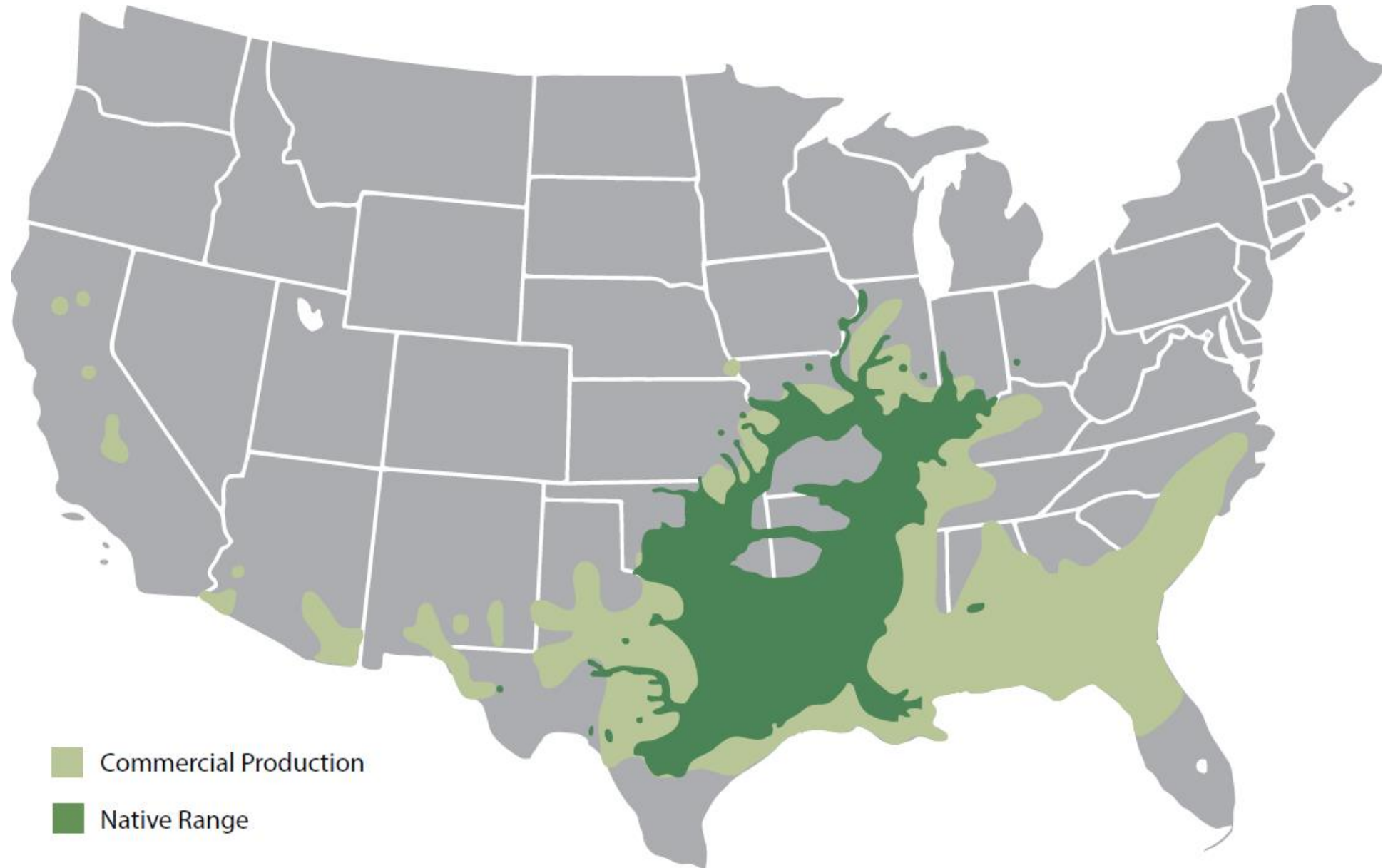
The Pecan

Between 2005 and 2011, US pecan production averaged **263,975,000 pounds per year**. Five states produced 82 percent of all US pecans.



Georgia 31.5%
New Mexico 21.9%
Texas 15.7%
Arizona 7.1%
Oklahoma 5.8%
Remaining states 18%

Native and Commercial Range of Pecan (*Carya illinoensis*)



U.S. Pecan Farms, Bearing and Nonbearing Acreage by State, 2007

State	# of Farms	All Pecan Acreage	Bearing Acres
Alabama	1,323	18,025	16,055
Arizona	196	12,365	11,950
Arkansas	312	11,396	8,698
California	283	3,128	2,487
Florida	963	8,652	6,741
Georgia	3,210	114,227	102,567
Kansas	215	6,178	5,265
Louisiana	778	16,557	12,952
Mississippi	673	14,343	11,321
Missouri	391	13,369	11,117
New Mexico	1,742	39,245	35,746
North Carolina	318	1,262	826
Oklahoma	3,589	141,675	124,553
South Carolina	634	4,600	3,813
Texas	6,625	174,929	150,426
Other ¹	604	1,858	1,664
U.S. TOTAL	21,856	581,809	506,181

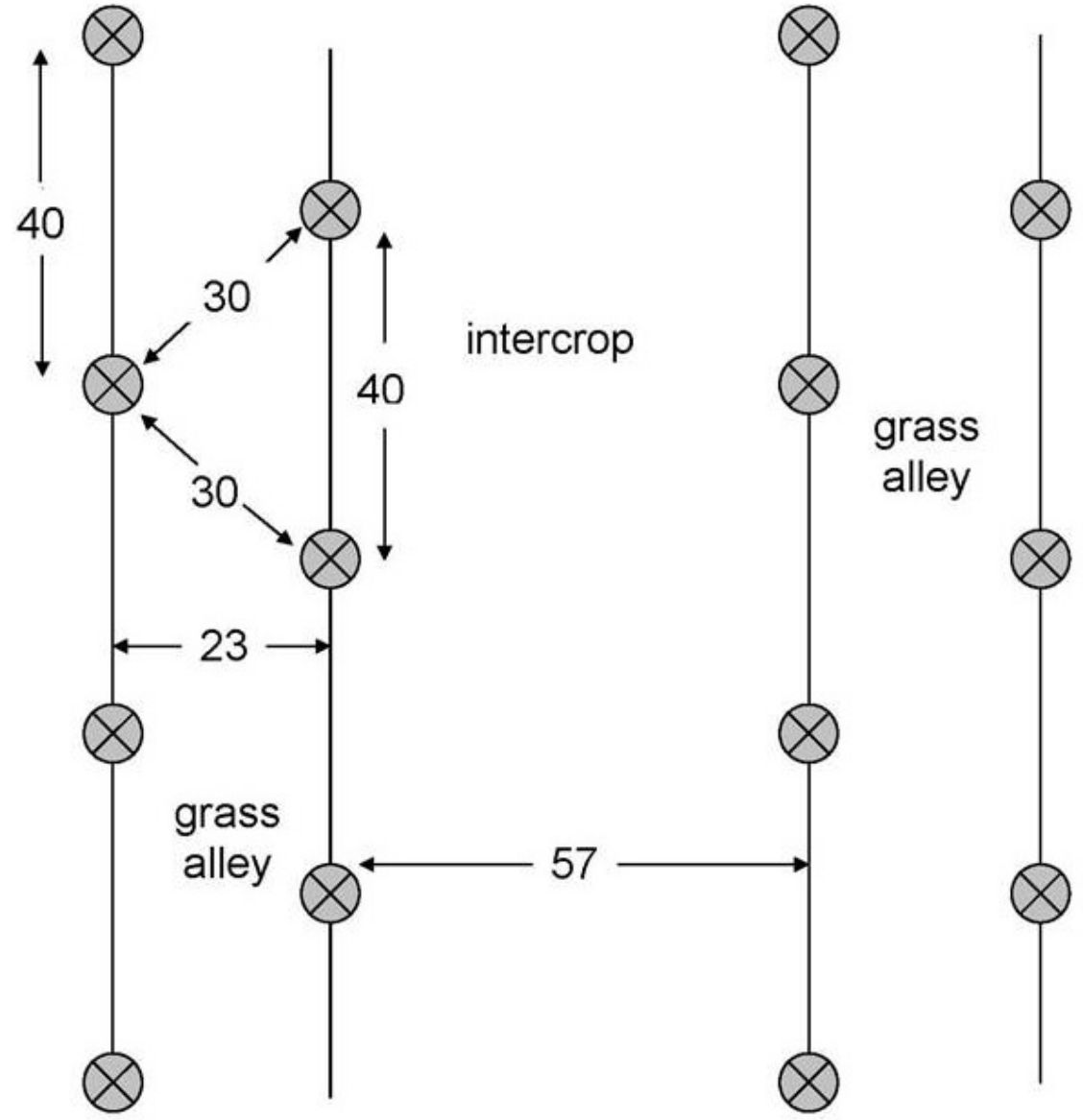
¹Colorado, Idaho, Illinois, Indiana, Iowa, Kentucky, Louisiana, Maryland, Michigan, Nebraska, Nevada, New Jersey, New York, Ohio, Pennsylvania, Tennessee, Utah, Virginia, West Virginia, and Wisconsin

Source: 2007 Census



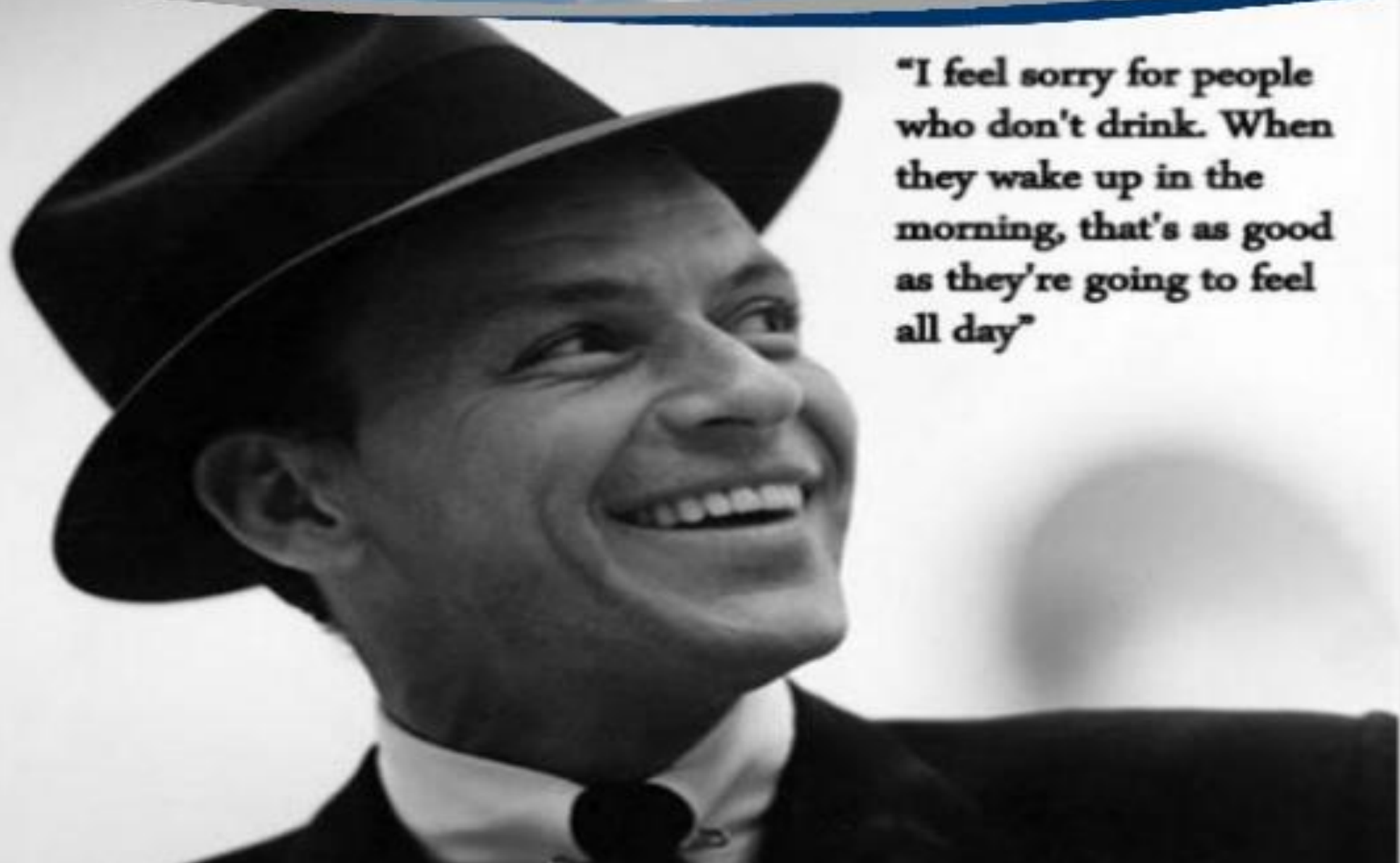


Figure 1. A double row planting plan for pecan orchards. Distances are in feet. Trees locations marked by circles.





Perspective Matters



"I feel sorry for people who don't drink. When they wake up in the morning, that's as good as they're going to feel all day"

“There has to be a better way to do it.”

-- Yates Adcock

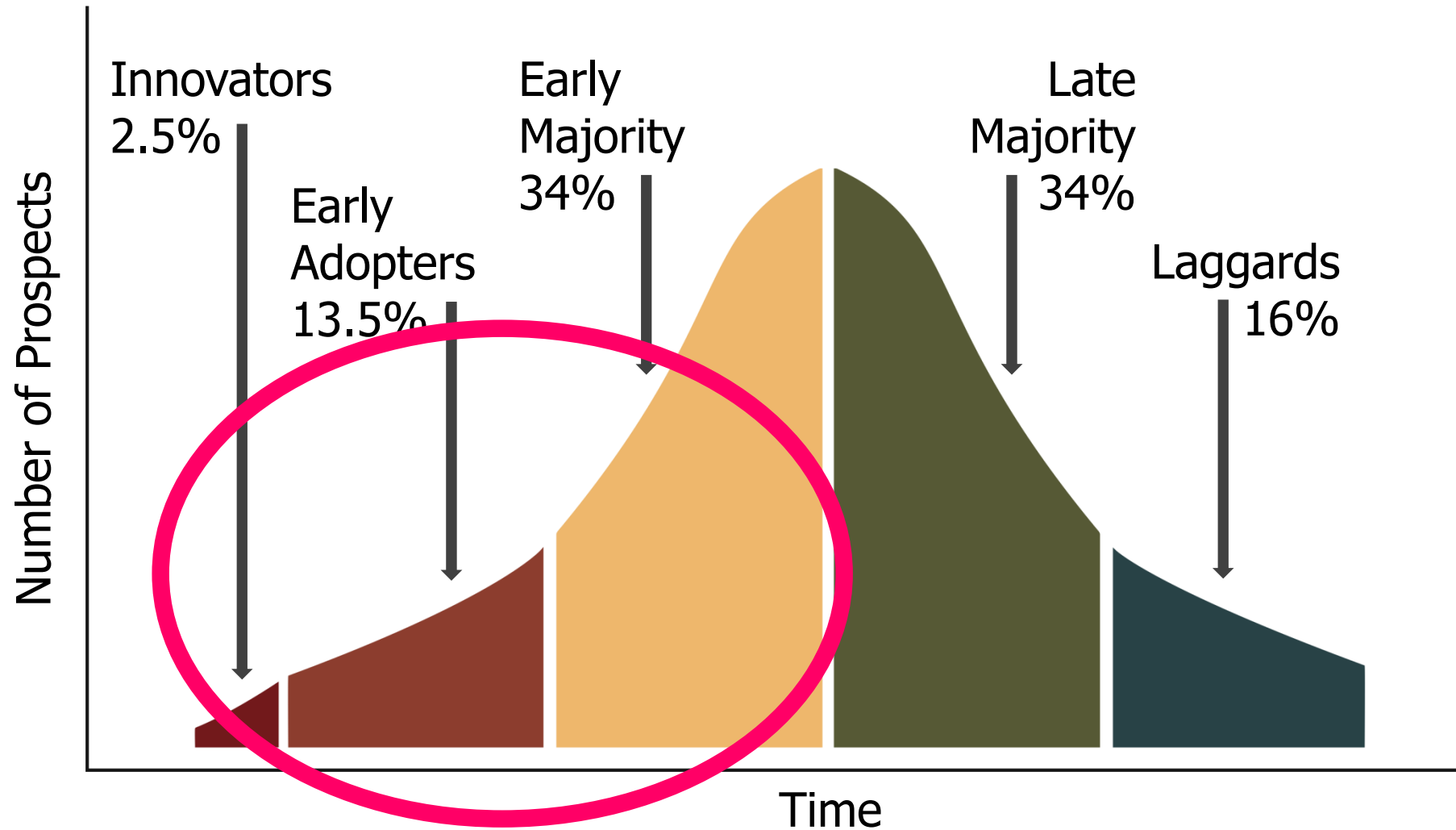


“Start with the end in mind.”

-- Yates Adcock



Catalysts for change



Private Land Stewardship/Conservation = Public Benefit



Partnership



THE SAMUEL ROBERTS
NOBLE
FOUNDATION

www.noble.org