

State of California
Department of Transportation
Engineering Service Center
Office of Structural Foundations
Transportation Laboratory

CALIFORNIA BANK AND SHORE ROCK SLOPE PROTECTION DESIGN

Practitioner's Guide and Field Evaluations of Riprap Methods

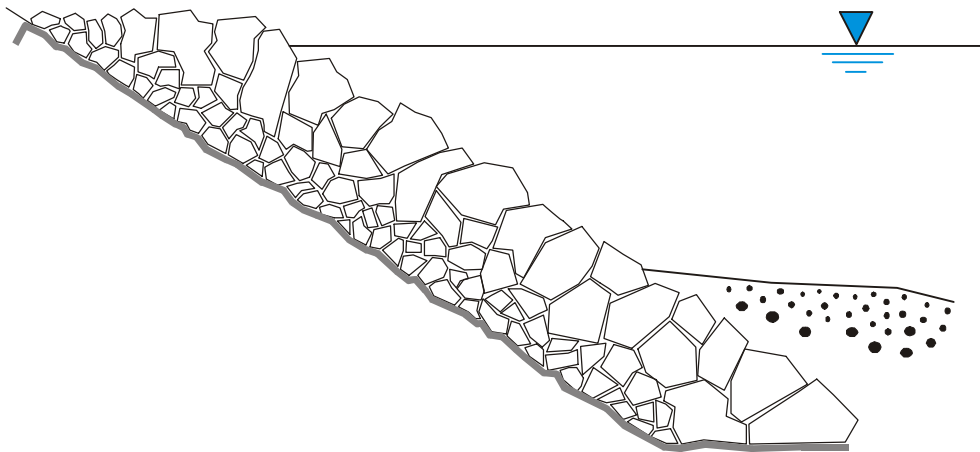

Final Report No. FHWA-CA-TL-95-10
Caltrans Study No. F90TL03

Third Edition - Internet
October 2000

Prepared in Cooperation with the US Department of Transportation
Federal Highway Administration

State of California
Department of Transportation
Engineering Service Center
Office of Structural Foundations
Transportation Laboratory

CALIFORNIA BANK AND SHORE ROCK SLOPE PROTECTION DESIGN

Practitioner's Guide and Field Evaluations of Riprap Methods

Final Report No. FHWA-CA-TL-95-10
Caltrans Study No. F90TL03
June 1996

Investigation by
Supervised by
Principal Investigator, Author
Co-Investigators, Co-Authors

Geotechnical Support Branch
Kenneth A. Cole, C.E.G.
James A. Racin, P.E.
Thomas P. Hoover, P.E.
Catherine M. Crossett Avila, P.E.



RICHARD C. WILHELMS, C.E.G., Chief
Geotechnical Support Branch

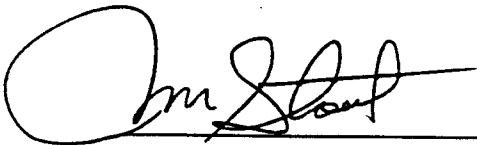

J. M. STOUT, P.E., Chief
Office of Structural Foundations



FR JOHN WEST, Program Manager
New Technology and Research



1. REPORT No. FHWA-CA-TL-95-10		2. GOVERNMENT ACCESSION No. PB 98-106453		3. RECIPIENT'S CATALOG No.	
4. TITLE AND SUBTITLE CALIFORNIA BANK AND SHORE ROCK SLOPE PROTECTION DESIGN Practitioner's Guide and Field Evaluations of Riprap Methods				5. REPORT DATE June 1996, Nov 1997, Oct 2000	
7. AUTHOR(S) JAMES A. RACIN, THOMAS P. HOOVER, and CATHERINE M. CROSSETT AVILA				6. PERFORMING ORGANIZATION	
9. PERFORMING ORGANIZATION NAME AND ADDRESS Caltrans Engineering Service Center Office of Structural Foundations - Transportation Laboratory 5900 Folsom Blvd. Sacramento CA 95819				8. PERFORMING ORGANIZATION REPORT No. 59316 637380	
12. SPONSORING AGENCY NAME AND ADDRESS California Department of Transportation (Caltrans) Office of New Technology and Research 1227 O Street Sacramento CA 95814				10. WORK UNIT No.	
				11. CONTRACT OR GRANT No. F90TL03	
				13. TYPE OF REPORT & PERIOD COVERED FINAL 1989 - 1996	
				14. SPONSORING AGENCY CODE	
15. SUPPLEMENTARY NOTES This research was done in cooperation with the US Department of Transportation, Federal Highway Administration (FHWA), project title: Seven Flexible RSP Design Methods: Examination, Field Validation, Selection.					
16. ABSTRACT The report clarifies the procedure of the California Bank and Shore (CABS) layered rock slope protection (RSP) design method. There are solved example problems, figures, and tables for practitioners who design and build flexible rock revetments by the CABS method. There are critical field evaluations of sixty-five sites tabled by location and design method. The authors and local practicing engineers in design, construction, and maintenance evaluated sites along stream and river banks or ocean shores in five states: Washington, Oregon, California, Colorado, and Mississippi. Sites were designed and built by CABS (velocity basis) and other effective methods (velocity, shear stress or tractive force basis): US Army Corps of Engineers, FHWA HEC-11, Coastal Engineering Research Center's Shore Protection Manual, CO Department of Transportation, Oregon Keyed Riprap, and the Denver Urban Drainage and Flood control District. Ninety photographs show significant design and construction features of riprap. The authors studied and annotated fifty-eight reference documents. Note on Nov 1997 Second Printing Out-of-print, see box 18 for hard copy (paper) distribution. There are several changes in the second printing. A significant change is on page 31, where the unit of W (minimum rock mass) is TONS in both equations 2 and 3. All 800 recipients of the first printing were notified of the page 31 errata. Another significant change is that three generic cross-section sketches are included in Appendix A (pages A-14 through A-16) to help readers draw typical sections for their contract plans. There are other minor changes, updated web sites, and typographical corrections. Recipients of the first printing may copy the following pages to make their document identical to this second printing: Technical Report Documentation Page (this page), iii, 19, 20, 28, 31, 32, 51, 57, A-1, A-9, A-10, A-13, A-14, A-15, A-16, B-10, and the caption of Photo C-86 on page C-43. JAR November 1997 Note on Oct 2000 Internet edition This 3 rd Internet edition is not distributed in hard copy by Caltrans, see box 18. Pages 19, 20, and 32 updated. JAR Oct 2000					
17. KEY WORDS riprap, rock, slope, protection, revetment, velocity, shear stress, tractive force, stream, river, bank, ocean, shore, erosion, design, construction, maintenance, fish habitat			18. DISTRIBUTION STATEMENT No restrictions. This document is available to the public. National Technical Information Service (NTIS) 5285 Port Royal Road Springfield VA 22161 phone 703-605-6000		
19. SECURITY CLASSIF. (OF THIS REPORT) UNCLASSIFIED		20. SECURITY CLASSIF. (OF THIS PAGE) UNCLASSIFIED		21. No. OF PAGES 154	22. PRICE

NOTICE

The contents of this report reflect the views of the authors who are responsible for the facts and the accuracy of data presented herein. The contents do not necessarily reflect the official views or policies of the State of California or the Federal Highway Administration. This report does not constitute a standard, specification, or regulation.

Neither the State of California nor the United States Government endorse products or manufacturers. Trade or manufacturers' names appear herein only because they are considered essential to the object of this document.

Acknowledgments

Excellence in your specialty areas and team effort helped us complete another research project. In-state and out-of-state travel to various riprap sites revealed many aspects of various design and construction methods, as well as maintenance problems. As with any field investigation, there simply was no substitute for "being there." For preliminary data-gathering efforts, arranging site tours, doing site and method evaluations, explaining subtleties of riprap gradations, design, and construction, and generally improving this report, we especially thank the following people:

Dr. Stephen T. Maynard	Steve Nakao
Dr. Daryl B. Simons	Bill Lindsey
Dr. Steven Abt	Paul Davies
Dr. Gary A. Carver	Dawn Foster
James C. Blodgett (retired)	Glenn DeCou
Dennis McBride	Joe Dobrowolski
Charlie Fielder	Christopher N. Dunn
John Bulinski	Dick Burnham (retired)
Dan Wing	Jim Lencioni
Dennis Grinzel	Lester E. Soule
Mark Moore	Charles D. Little, Jr.
Lance Gorman	Dave Bryson
Don Lane	Ben Urbonas
Fred Boucher (retired)	Barbara Benik
John Wright (retired)	Frank Rosso
Carroll Harris (deceased)	Gary Johnson
Dennis Jagoda	Rick Moser
Cid Tesoro	John McCarty
	Ken Cole

We listened to and recorded several narrations about rock slope protection by many other experienced professionals in Caltrans and other agencies, who are not listed above. We thank and recognize these people and cite them as our key sources of information in the separate Chapter 9, "Personal Communications."

When faced with designing riprap or storm damage projects, we encourage readers to continue the worth-while effort of documenting field reviews in their normal practice.

JAR TPH CMCA

CONTENTS

<i>Chapter</i>	Page
1. Introduction	1
Background	1
Objective and Overview of Investigative Process	1
Executive Summary	1
Selecting the Investigative Process	4
Critique of Investigative Process and CABS Design Method	5
2. Conclusions	7
3. Recommendations	15
4. Implementation	19
5. California Layered RSP Design Method	21
5-1. Procedure for Designing Layered RSP on Banks of Rivers and Streams	22
5-1-A. Collect River/Stream Data	22
5-1-B. Inspect Site	22
5-1-C. Determine Minimum Stone Weight	23
5-1-D. Determine RSP-Class of Outside Layer	24
5-1-E. Determine the Required Layers of RSP	27
5-1-F. Determine the Thickness of the RSP Revetment	29
5-1-G. Review Hydraulic Calculations at Site With RSP and Possibility of Vegetation	30
5-2. Rock Sizing Equations for Ocean Shore Protection and Data Sources	31
5-2-A. Shoal Water and Deep Water Equations	31
5-2-B. Design Advice	32
5-2-C. Other Data Sources	32
6. Investigative Process	33
7. Field Evaluations	37
8. Annotated References	57
9. Personal Communications	71
 <i>Figure</i>	
5-1. Key Variables of Equation 1	23
5-2. Key Variables of Equations 2 and 3	31

CONTENTS

	Page
<i>Table</i>	
1-1 Field-evaluated RSP Design Methods	3
2-1 Effective RSP Design Methods	7
5-1 Guide for Determining Outside Layer RSP-Class	25
5-2 California Layered RSP	28
5-3 Minimum Layer Thickness	30
6-1 Data Guide and Questions for Field Evaluations	36
7-1 Site Tallies by RSP Design Method	37
7-2 Field Evaluations	39
 <i>Exhibit</i>	
6-A Inquiry for RSP Site Information	35
 <i>Appendix A. Solved Problems and Figures</i>	
Problem A-1 Impinging Flow	A-2
Figure A-1. RSP Toe Embedded Below Riverbed	A-11
Figure A-2. RSP Toe Mounded on Riverbed	A-11
Problem A-2 Parallel Flow	A-6
Figure A-3. Layered RSP With Cover Soil	A-12
Figure A-4. Alternate Layered RSP With Cover Soil	A-12
Problem A-3 Concreted-RSP	A-8
Figure A-5. Concreted-RSP with Embedded Toe	A-13
Figure A-6. Construction Notes for Concreted-RSP	A-13
Generic Cross-sections	
Figure A-7. CA Layered RSP with EMBEDDED Toe	A-14
Figure A-8. CA Layered RSP with MOUNDED Toe	A-15
Figure A-9. Concreted-RSP Construction Details and Notes ..	A-16
 <i>Appendix B. Excerpts of Caltrans Specifications</i>	
Standard Specifications	
Section 72-2 Rock Slope Protection	B-1
Section 72-5 Concreted Rock Slope Protection	B-5
Section 88-1.04 Rock Slope Protection Fabric	B-8
Standard Special Provisions	
72.01 Slope Protection	B-9
Mtls M 81 Engineering Fabrics	B-9
72.15 Rock Slope Protection Fabric	B-10
Addendum to SSP 72.15 Minimum Permittivity of RSP-fabric ...	B-10

CONTENTS

	Page
<i>Appendix C. Captioned Photographs of Selected Sites</i>	C-i
<i>Photo</i> First Phrase of Caption	
C-1 Parallel and impinging flow	C-1
C-2 Bank which gets impinging flow	C-1
C-3 U/S view from top of impinged bank at 90 degree bend	C-2
C-4 Repaired zone of impinged bank at 90 degree bend	C-2
C-5 Maintained dike bank (left) and natural bank (right)	C-3
C-6 Partially toppled willow	C-3
C-7 Toe was mounded 3-feet vertical by 8-feet horizontal	C-4
C-8 Tree toppled by current	C-4
C-9 Rock and tree stump retards (permeable jetties, groins) along levee, also called "fish habitat" or "fish cluster" structures	C-5
C-10 Fish habitat structure	C-5
C-11 Riprapped toe and plastic geogrid gabions	C-6
C-12 Close-up of plastic geogrid gabion and vegetation	C-6
C-13 Repaired zone where flow impinges	C-7
C-14 Rock hammer impact, field test	C-7
C-15 Permeable rock jetties (fish habitat structures)	C-8
C-16 Close-up of permeable rock jetty	C-8
C-17 RSP tied to solid rock outcrop, natural impermeable retard (jetty)	C-9
C-18 Soil-filled voids, natural vegetation	C-9
C-19 Channel cut through deposited beach sand	C-10
C-20 Layers of deposited sand	C-10
C-21 Large "hydraulic opening" under bridge to pass flow and debris	C-11
C-22 Layered RSP protects bridge abutment fill	C-11
C-23 Rocks of well-graded mixture displaced by storm waves, 1 of 2	C-12
C-24 Rocks of well-graded mixture displaced by storm waves, 2 of 2	C-12

CONTENTS

<i>Photo</i>	First Phrase of Caption	Page
C-25	Primary cover stone on southerly abutment fill	C-13
C-26	Outside layer (primary cover stone) 2070#-1240#	C-13
C-27	Failed riprap, levee bank	C-14
C-28	Gravel bar (2nd one U/S) directs impinging flow at westerly bank (left)	C-14
C-29	Route 58 bridge	C-15
C-30	Toe of rigid concrete-filled fabric undercut	C-15
C-31	OR Keyed Riprap, overview of left bank	C-16
C-32	OR Keyed Riprap, close-up at left bank	C-16
C-33	Keyed riprap by Corps of Engineers, Portland	C-17
C-34	Keyed riprap by Corps of Engineers, Seattle	C-17
C-35	88th Avenue, 1 of 4	C-18
C-36	88th Avenue, 2 of 4	C-18
C-37	88th Avenue, 3 of 4	C-19
C-38	88th Avenue, 4 of 4	C-19
C-39	Parallel flow, bank protected with Denver UDFCD Type L riprap	C-20
C-40	Natural growth contrasted to non-revegetated riprapped dike	C-20
C-41	Impinging flow, bank protected with Denver UDFCD Type M riprap	C-21
C-42	Riprapped levee covered with soil and revegetated above Q5 stage	C-21
C-43	Denver UDFCD Type L riprap below 3-foot drop structure failed, repaired with concreted rock	C-22
C-44	Denver UDFCD concreted Type L transition to Type L riprap OK	C-22
C-45	Permeable rock retard (jetty) and check dam	C-23
C-46	CO DOT HEAVY riprap	C-23
C-47	Rough surface boundary created with riprap	C-24
C-48	Willows growing well through concreted-RSP	C-24

CONTENTS

<i>Photo</i>	First Phrase of Caption	Page
C-49	CO DOT HEAVY riprap and one timber crib	C-25
C-50	Observer on topmost beam of timber crib among willows	C-25
C-51	Archaeological site protection causes impinging flow	C-26
C-52	Impinging zone D/S and opposite archeological site	C-26
C-53	Longitudinal stone toe and tieback (permeable rock retard, hard-point dike)	C-27
C-54	Longitudinal stone toe and tiebacks	C-27
C-55	Rural county road bridge over incised streambed	C-28
C-56	Baffle and modified Agricultural Research Service grade control structure with R1000 riprap	C-28
C-57	Grade control structure with failed R400 riprap, 1 of 2	C-29
C-58	Grade control structure with failed R400 riprap, 2 of 2	C-29
C-59	Steel sheet pile grade control structure and riprap	C-30
C-60	Concrete-filled, steel-pile baffle	C-30
C-61	Dense vegetation naturally regenerated among riprap on impinging (left) bank	C-31
C-62	Dense vegetation in naturally silt-filled voids of riprap	C-31
C-63	Elevation limit of naturally deposited silt	C-32
C-64	Zone of sparse vegetation on upper half of riprapped slope	C-32
C-65	Soil placed on slope over riprap above ordinary high water (OHW) for planting	C-33
C-66	Unstable silt deposit, 6-feet thick	C-33
C-67	Mad River Mouth / Pacific Ocean at low tide	C-34
C-68	Mad River Mouth / Pacific Ocean at ebb tide	C-34
C-69	Loader-mounted dispenser holds 20' wide x 250' long roll of RSP-fabric	C-35
C-70	Four-man team positioned and sewed RSP-fabric	C-35

CONTENTS

<i>Photo</i>	First Phrase of Caption	Page
C-71	Z-folding RSP-fabric in bottom of pit	C-36
C-72	Thin sand layer on Backing No. 2 protects rubber tires of equipment during turning movements	C-36
C-73	Inspecting special rock mixture, 8-ton maximum	C-37
C-74	Mad River RSP facility after 2 years	C-37
C-75	Southerly limit of 1992 RSP project and remainder of dune below vista point	C-38
C-76	Dumping rock down 14-foot bank, normally not done, sizes segregate	C-38
C-77	RSP leading edge notched into bank	C-39
C-78	Leading edge of layered, launchable 4-ton RSP after 9 months	C-39
C-79	West-turn RSP at mouth of Mad River after 3 years	C-40
C-80	Trailing edge localized erosion beyond layered, launchable 8 ton RSP-sand interface	C-40
C-81	RSP tied to natural rock outcrops	C-41
C-82	Toe stabilized with 4 ton RSP-class, upper bank is 1 ton	C-41
C-83	Leaning alders stressed by recent high water events	C-42
C-84	Level line between observers' hats is near highest observed water (1964)	C-42
C-85	Failed banks and channel invert protection	C-43
C-86	Woven-tape geotextile (slit-film), inappropriate as RSP-fabric on banks	C-43
C-87	Repaired channel with CA 1-ton RSP-class and oversized rock allowed	C-44
C-88	Downdrain extends below and beyond top of riprapped channel sides	C-44
C-89	Sediment fan in stilling pool behind gabion weir grade control structure	C-45
C-90	6'-2" tall observer on stable +8-ton rock near end of channel	C-45

1. Introduction

Background. Rock Slope Protection (RSP) is among various bank and shore protection materials and methods. RSP, also called rock riprap or riprap, consists of one or more layers of rock; it is placed along river and streambanks, or along ocean and lake shores to prevent erosion. This report focuses on flexible RSP, emphasizes the California Bank and Shore (CABS) layered RSP design method, and documents how CABS and other methods have been implemented in engineering practice. Depending on context, RSP can either be the whole rock-armored revetment or one of the riprap layers. Each layer is graded, that is, there are specified percentages of rock within standard weight (size) ranges. Depending on the gradation, weights can range from a few pounds to several tons (less than a kilogram to tonnes). From the stream to the bank, a typical revetment would consist of a large-sized "outside" RSP layer, a small-sized "inner" RSP layer, and then a geotextile against the erodible bank. RSP revetments are flexible, that is, rock may move to more stable positions by hydraulic forces of flowing water, wave action, and/or gravity, without necessarily compromising the stability of the entire bank. Soil can naturally fill voids among rocks, or it can be placed so vegetation will grow to provide shade and wildlife habitat. Such soil may be scoured away by events of moderate velocity and/or high river stage.

Objective and Overview of Investigative Process. A key step in any RSP design method is determining minimum stable stone (rock) size of the outside layer. There are several theoretical studies that compare rock-sizing equations of various methods with graphs of velocity versus stone size. In those studies, it appears that the CABS RSP design method produces oversized rock, and therefore facilities designed by the CABS method seem overdesigned. Our *objective was to decide whether the CABS method was valid and should continue to be used, or if not, which other method(s) are recommended.* Instead of theoretical studies, our *investigative process emphasized field-evaluating RSP facilities designed and built by various methods.* We first learned all the methods from the literature, and when possible, we interviewed authors of methods. After the literature study, we field-evaluated RSP facilities in five states: Washington, Oregon, California, Colorado, and Mississippi.

Executive Summary. There is enough field evidence to support continued use of the CABS RSP design method. After critically reviewing Reference 1^A (CA Division of

^A "Reference 1" is the first document cited in Chapter 8 "Annotated References."
Subsequent documents are numbered and shown in the order they were studied.

Highways), often called the "bank and shore manual" that introduced the CABS method in 1960, we found the procedure unclear. Other reports also show the CABS rock-sizing equation, but none of them adequately describe the design procedure. Therefore, Chapter 5 herein clearly presents the **CABS layered RSP design method**. Appendix A has solved problems and the corresponding problem-specific cross sections. Appendix B has portions of the Caltrans *Standard Specifications*, as they pertain to Chapter 5 and Appendix A.

This report is useful to engineers and practitioners for designing RSP bank and shore protection facilities, and to researchers as documentation for future evaluations of RSP sites and design methods. While stone size and stream velocity are two important factors that contribute to the success or failure of RSP revetments, conclusions of Chapter 2 and recommendations of Chapter 3 are based on critical evaluations of RSP revetments in the field, not only on theoretical stable rock size and velocity. The photographic study in Appendix C highlights significant features of various RSP facilities that support our findings and clarify text. Chapter 4 presents a plan to implement the findings, Chapter 6 documents the investigative process, Chapter 7 documents field reviews and evaluations, and Chapter 8 lists references with annotations by Racin about each document. Our key sources for evaluating the various RSP design methods are engineers and practitioners listed in Chapter 9.

Table 1-1 lists RSP design methods that were field-evaluated, were found effective, and are used in engineering practice among five states. In WA, OR, CA, CO, and MS, we field-evaluated sixty-five RSP sites (Chapter 7 Table 7-2). The RSP facilities were either successful or had failed and were repaired. Our inquiry for site information (Chapter 6 Exhibit 6-A) defines successful sites as having little or no maintenance after being exposed to design flows. Failed sites are characterized by frequent repairs after less than design flows. The oldest site we evaluated was built in 1948 and the most-recent in 1995; our database spans 47 years. Among 53 sites, the average useful service-life is more than 16 years (unknown age at 12 sites). About one third of the sites needed some repair or maintenance, however as of June 1996, all 65 sites are functioning well.

The CODOT method is a variation of Reference 5 (Anderson et al, National Cooperative Highway Research Program, NCHRP Report 108) and Reference 8 (Norman, "old" HEC-15). No RSP sites were found or field-evaluated that were based directly on Reference 8 or Reference 11 (Chen & Cotton, "new" HEC-15). The design method in Reference 2 (US Bureau of Reclamation, EM-25) is for stilling basins below dams and for culvert outlets, not for banks or shores. There were two sites in California that were probably based on Reference 9 (Roehl et al, ASCE Manual 54). A possible method in

proposed Reference 15 (Blodgett & McConaughy) was not published, and no sites were built by that method in time for field evaluations. Although widely published and cited, no RSP sites were field-evaluated that were based directly on Reference 10 (Simons & Senturk).

Table 1-1. Field-evaluated RSP Design Methods

Abbreviation / Name of Method	Basis	Reference
CABS / California Bank and Shore - river equation " / " shoal water equation " / " deep water equation	velocity tides, scour wave height	1
FHWA's HEC-11 / Federal Highway Administration's Hydraulic Engineering Circular No. 11	velocity [A]	3, 12
CORPS / US Army Corps of Engineers Engineering Manual 1110-2-1601	velocity [B]	4
CERC / US Army Coastal Engineering Research Center's Shore Protection Manual	wave, tides	45
CODOT / Colorado Department of Transportation	shear stress	7
OR Keyed / Oregon Keyed Riprap	velocity	17
DUDFCD / Denver Urban Drainage Flood Control District	velocity	55

Notes. [A] Converted from shear stress. [B] Formerly shear stress.

Costs for designing and building the RSP sites were usually not available. In roadway and bridge work, few contracts are let exclusively for building RSP. Cost data are skewed by other items in bid packages, that is, in the competitive bid process rock prices can vary widely, because rock may not have been the major item of work. Therefore relative cost of an RSP facility was simply judged as either *expensive* or *inexpensive* by the engineers and practitioners, who field-evaluated the RSP sites with us. Among sixty-five sites in Table 7-2, eight were judged as *expensive*. A few contracts had claims, which inflated costs of all items. For a few other sites, initial construction was not expensive, but the sites were rated as *expensive* because of frequent maintenance. Hydraulic data were not readily available to us for most sites, however, for a few sites we were given copies of formal hydraulic study reports. Despite gaps in cost and reported hydraulic data, enough field evidence was available to adequately rate each site in Table 7-2 and each RSP design method in Table 1-1.

The CABS layered RSP design method is preferred on Caltrans projects. Other valid RSP design methods are listed in Table 1-1, and the nearly identical Table 2-1 shows the most recent editions of each reference. See Chapter 8 for complete bibliographical data. As-evidenced by field evaluations of RSP sites in Table 7-2 and other sites not included in this report, there are maintenance problems and failures with any RSP design method. Constructing layers of riprap, an adequate toe, and leading and trailing edges (also called cutoffs or flank treatments) are features that tend to assure riprap revetments that will function well with infrequent maintenance.

A poor practice for building an RSP facility is simply to place large rock that is sized as the "outside" layer along an erodible bank without placing any "inner" layers. Such practice is probably justified as a flood-fight response, where large-sized riprap may be the only material available, and when there is no time to properly construct a layered revetment. However, after floods recede, simply placing more large rock is poor practice. In those and similar bank protection efforts, if the bank fails, it is not necessarily the fault of the design method. Such practice will not work for long-term bank protection, because without layers of adequate thickness and gradation, erodible bank materials will ultimately pipe through voids and the bank will have failed again.

Selecting the Investigative Process. We opted to do field evaluations instead of theoretical "paper studies." The *dependent variable* of studying RSP design methods would naturally be stone size, and the *independent variable* would be velocity. Three approaches were considered. The first approach was to measure rock sizes and velocities at several sites. That would require a long duration of observations at various sites, because velocity depends on more than just local geometry. Velocity depends on climate, runoff quantity, changes in river and stream morphology, and other hydrologic factors like changes in watershed land uses, storage, and infiltration. A second approach was to build side-by-side RSP revetments designed by various methods. It would have been very expensive to build several side-by-side revetments in different climates and hydrologic regimes, and we still needed a long duration of observations. Neither of these first two approaches were feasible, expedient, nor within the budget. The third approach we considered and decided on was to field-evaluate RSP sites with local engineers and practitioners. These people had design, construction, and maintenance experience with one or more of the design methods, and they were familiar with RSP sites in their respective localities. We interviewed the engineers and practitioners, listened to their narratives, exchanged our views, recorded data, and photographed each RSP site. After assessing and rating the sites, we then judged the RSP design methods.

While determining the success or failure of an RSP site initially seemed simple, we quickly discovered that people were reluctant to admit "failures." "Failure" had to be defined. Therefore, we developed an inquiry for data and stated our definitions of success and failure (Exhibit 6-A). Inquiries were sent to engineers in WA, OR, CA, CO, and MS. Responses for successful and failed sites revealed that most sites are not normally field-evaluated after they are built. The number and duration of flow events that exceed the design event are among data required for evaluating an RSP site, and hence the design method. Such hydraulic exposures are not routinely recorded, because RSP sites are not normally instrumented. Therefore, sites for evaluation were selected by local engineers and practitioners among the five states, who were familiar with recent hydrologic/hydraulic events, various RSP sites, and site-specific nuances.

We developed a data guide with questions for field evaluations (Table 6-1) and recorded data that were available. We audio-taped and later reviewed interviews with the engineers, practitioners, and other RSP researchers. We compiled an extensive photographic record of RSP sites. To make and defend conclusions (Chapter 2) and recommendations (Chapter 3), we condensed data from each site and present our database as Table 7-2. The determination of success or failure at each site was made by experienced local engineers and at least two of the authors of this report. Each RSP facility was evaluated with site-specific subtleties in mind and with the benefit of each evaluator's additional nondocumented professional experience. We judged an RSP design method as effective (that is, valid, satisfactory, OK), as long as there was at least one successful RSP site, and preferably several sites, to affirm our judgment.

Critique of Investigative Process and CABS Design Method. Some reviewers of early drafts of this report looked for comparative calculations of stone size versus velocity. Theoretical presentations of that kind were already done by several authors, the best of which is in Reference 10 (Simons & Senturk). Other reviewers looked for "conventional data analysis" of site information: graphs, tables, and statistical routines. No conventional data analyses were done. Initially we thought we would find and assemble data that could simply be plugged into parametric and/or nonparametric routines. Instead we found that such data are sparse and not typically kept in design files, namely velocity, assumptions, and the method for arriving at riprap size. We found only a few RSP-site evaluations in Reference 6 (Anderson) and Reference 14 (Blodgett & McConaughy), but those did not cover all the methods listed in Table 1-1. We also found that hydraulic units within departments of transportation are not staffed with enough people to complete and periodically update an RSP inventory along roads. By 1982 the Hydraulics Unit of Caltrans District 1 in Eureka completed an RSP inventory for state roads

in northwestern California, but there have been no updates since then.

Theoretical "paper studies" are documented in Reference 12 ("new" HEC-11's Appendix D, Figures 61, 62, and 63) and in Reference 14 (Blodgett & McConaughy). Those studies show graphs of velocity versus **minimum stable stone size**, using the rock-sizing equation for each method. When plotted with other methods, the CABS rock-sizing equation gives larger rock sizes than some other equations. Some engineers thought that because the CABS method gives larger rock sizes, revetments would be overdesigned and more expensive than if they were sized by other methods. A common supposition is: for the same velocity, placing smaller rock sizes will be less costly. In fact, producing small rock from large rock could be more costly, due to larger amounts of explosives and more time and effort required to sort material for producing lighter riprap gradations. Another supposition is that well-graded riprap works better than uniform-sized riprap. Reference 5 (Anderson et al, NCHRP Report 108) does not support that supposition. Finally, RSP-classes (gradations) lighter and smaller than Backing No. 3 (see Table 5-1 herein) per Caltrans *Standard Specifications* are needed. With the development and widespread use of geotextiles, such lighter or smaller RSP-classes are normally not required, provided that the selected RSP-fabrics have adequate strength, resistance to ultraviolet degradation, and adequate capacity to pass water perpendicular to the plane of the fabric (permeability).

2. Conclusions

1. In Washington, Oregon, California, Colorado, and Mississippi, there are seven RSP design methods that are effective and are practiced routinely. The methods and supporting documents are:

Table 2-1. Effective RSP Design Methods

Abbreviation / Name of Method	Reference No. - edition
CABS / California Bank and Shore	Chapter 5 herein [A]
CORPS / US Army Corps of Engineers	4 - 1994
CERC / Army Shore Protection Manual	45 - 1984
CODOT / Colorado Department of Transportation	7 - 1987
OR Keyed / Oregon Keyed Riprap	17 - 1975
DUDFCD / Denver Urban Drainage Flood Control District	55 - 1984
HEC-11 / Federal Highway Administration (FHWA)	12 - 1989

[A] If needed, supplement with Reference 46 - 1995, or if available Reference 1 - 1970.

No field sites were identified or were field-evaluated in this study that were based directly on Reference 8 (Norman, "old" HEC-15) for roadside channels, Reference 2 (US Bureau of Reclamation, EM-25) for stilling basins and ends of culverts, or Reference 10 (Simons & Senturk) for channels. No conclusions or recommendations are made regarding these latter three methods.

2. All reviewed literature and personal interviews with design, construction, and maintenance engineers show that designing and constructing **layers** of riprap is normal practice for both river bank and ocean shore protection. Omitting layers is the exception and is done when it is unavoidable, like during a flood-fight, or when the backslope material consists of small-sized and free-draining rock.

Table 873.3B in Reference 46 (Caltrans, *Highway Design Manual*), can lead inexperienced designers astray, because it does not advise including inner layers (RSP-fabric, Backing, and/or other RSP-classes) in riprap designs. Whether for impinging or parallel flow, the values of velocity, RSP-Class, and layer thickness in Table 873.3B are valid only for the outside layer. For the CABS method, layers and minimum thickness values are respectively shown in Tables 5-2 and 5-3 herein.

3. There are no field data to justify changing rock gradations in the Caltrans *Standard Specifications*, Section 72-2. The table in section 72-2.02 is clearly labeled **PERCENTAGE LARGER THAN**, however, many people misconstrue Caltrans requirements as *percent smaller than* or *percent passing*. Table 5-1 clarifies the gradation table on page 72-1 Section 72-2 of the Caltrans *Standard Specifications*. For each RSP-Class, although the table has three ranges (in percent) for each standard rock size, it is still possible for quarries to produce acceptable gradations of nearly the same-sized rocks for Caltrans projects.

In flume stability studies, there are some data that support using rock gradations that follow smooth size distribution curves, as depicted in Figure 7.19 of Reference 10 (Simons & Senturk). According to literature cited in Reference 3 (Searcy, "old" HEC-11) and in Reference 5 (Anderson et al), flume tests showed satisfactory performance was achieved when layers of RSP were constructed from rocks of nearly the same size, as compared to gradations with a wide assortment of sizes. For satisfactory performance, revetments built with rocks of nearly the same size had adequate thickness, and shapes were angular to sub-angular, so the rock *interlocked*. Rock interlocks well when shapes are angular to sub-angular. For rock shapes, see Reference 57 (Swanson & Fox). Stable revetments can be built with rounded rock, as long as the slope is not steeper than 1V:2.5H or 1V:3H.

All RSP revetments flex and move when they are subjected to various forces acting on them: hydraulic, gravity, and/or seismic. If the outside layer of RSP is too thin, or if the rock is graded with very large and very small rocks with few intermediate-sized rocks (a "gap-graded" mixture), the revetment does not resist forces very well, and it will likely fail. In thin revetments, as the outside layer deteriorates, underlying smaller rocks wash out through voids. Rocks adjust and continue to protect the bank, as long as there is adequate thickness.

Guidance for the thickness of rock layers varies. For the CORPS method Reference 4 (US Army Corps of Engineers) recommends at least 1.5xD50 or 1.0xD100, whichever gives the thicker layer. D50 and D100 are, respectively, the effective diameters of the median sized rock and the maximum sized rock in the gradation. For the CABS method minimum thickness is 1.5xD50 for "Method A" individually placed rocks that have three-point bearing (rocks do not wobble). As shown in Table 5-1, Method A can be specified for RSP-classes 1/2-ton and larger. Minimum thickness for "Method B" RSP is 1.875xD50 (25 percent thicker than Method A). Method B riprap can be specified for RSP-classes 1-ton and smaller. Method B RSP is spread to its

final position by machine after it has been dumped nearby.

Method B RSP is also called "dumped RSP." When the only choice is to end dump rock under water, the factor $1.875xD50$ or larger should be used to estimate layer thickness. Dumped RSP does not mean that rock should be dumped down slopes from high banks. Sizes will segregate, and as rocks gain momentum down the slope they may roll beyond the plan view limit. Work should normally progress from low to high elevation, so thickness is controlled and size segregation is limited. Photo C-76 shows a controlled dumping operation, where the bank was not very high, and a rock berm at the toe of slope kept rocks from rolling beyond the plan view limit.

4. There is no precise method for calculating whether an RSP facility is oversized or overbuilt. Field evaluations in Table 7-2 suggest that with any of the design methods, some RSP facilities may have been oversized or overbuilt, or both oversized and overbuilt. Capital and maintenance costs of an RSP facility are weighed against issues of property damage and public safety, that is, personal injury and/or loss of life. Determining risk is subjective, and designers tend to be conservative and overdesign. Construction engineers overbuild because of inspection practices, which include:
 - a. lack of experience in estimating rock size and gradation,
 - b. inspection at the quarry with few or no job-site inspections, and
 - c. reluctance to send trucks with oversized rock back to the quarry.

Overdesign occurs within any of the RSP design methods, when conservative measures are applied in each step of a multi step procedure, or when sensitive input variables are increased arbitrarily in equations for determining minimum stable rock size. For example, in the California "river and stream bank equation," (see Section 5-1-C, Equation 1) velocity is raised to the sixth power, and arbitrarily increasing the velocity will produce much larger rock sizes than if the velocity were not increased.

Overdesign might also result from assigning a recurrence interval higher than warranted. For example, if roadway drainage and culverts were designed to pass storms of a 25-year return interval, (4 percent probability of occurrence), and if a 100-year storm (1 percent probability) were used to design the RSP, then the RSP could be considered oversized.

5. There is no simple rule for selecting the design storm return interval. Based on long-term practice, designing by "extreme value criteria," that is, selecting a design storm with low probability of occurrence, is common and is justifiable from safety and

economic perspectives. For any RSP design method, the design storm is selected by a combination of experience, local criteria, and policy. Part of the philosophy and engineering practice in most states is to design and construct bank protection as expendable, but not at the expense of public safety, and not with the expense of frequent maintenance. RSP might appear oversized along roads of sole access for emergency vehicles and supplies, but such roads warrant designing for a higher return period.

In California practice, guidance for the waterway under bridges (cross-sectional open area) on federal and state highways is to pass the 50-year storm with sufficient freeboard for debris. Also, current California practice is to design so that the bridge maintains structural integrity even if the abutment fills wash out. However, whether the RSP is at a bridge or along the roadway, factors to consider for selecting the design storm return interval for sizing RSP are: risk to personal safety, loss of roadway fill that could lengthen detours and increase travel times, the cost of rebuilding the fill and constructing a layered revetment with adequate toe and flank details, and the availability of suitable rock.

Design storms must be updated periodically, on a regional scale or even at a specific site, based on recent high-water events, damages, and as additional gaging data become available. Volume and duration of runoff are responses of global and regional weather patterns, which have large variations and are not easily forecasted. Velocities and flow rates depend directly on land characteristics and usage. While changes to the land might seem of little or no significance at a particular location and time, the individual or cumulative effects of such changes may not be realized until later, and usually after a flood event.

6. Velocity-based design methods are more commonly used than shear-stress methods. Shear-stress methods are cumbersome and require estimates of soil parameters. Engineers who design RSP facilities typically have hydraulic engineering experience, while few have geotechnical experience.

For velocity-based methods, obtaining velocity values can be a challenge, considering that there are only a few stream gaging stations, as contrasted with the number and location of sites that have or need RSP revetments. Velocities are rarely measured during flood events. However, local stream geometry can be measured, and flow rates can be estimated. Nearby stream gaging stations can be used to estimate design discharge. Then other methods such as step backwater models and/or normal

depth analyses can be applied to estimate velocity for the design discharge. Recent high water stages can be found by observing elevations where driftwood, twigs, and debris are trapped in vegetation, and where silt stains are on nearby trees, bridges, or other structures. For less recent events, high water elevations can be located by interviewing eyewitnesses, like maintenance crews and local residents, who might have photographs or video recordings.

In channel bends where flow impinges on the outside bank, it is normal practice to multiply the average stream velocity by a factor greater than one, and then use the rock-sizing equation (for example, Section 5-1-C, Equation 1). The resulting rock size will be larger than if the flow were parallel to the bank and not impinging on it. For impinging flow in the CABS method, the factor 1.33 is recommended and is usually satisfactory. For parallel flow in the CABS method, the average velocity is multiplied by 0.67. Some reports erroneously report that in the CABS method "velocity for impinging flow is doubled." An accurate statement is: "the impinging flow velocity is twice the parallel flow velocity," meaning for the general case, parallel velocity is $\frac{2}{3}$ average and impinging velocity is $\frac{4}{3}$ average. Based on near-prototype flume studies by Dr. Stephen Maynard at the Waterways Experiment Station in Vicksburg MS, factors of about 1.5 to 1.6 are reasonable for the CORPS method. Based on experience in some Corps districts, the factor 2.0 has been used.

Altered stream morphology from debris like a tree-snag or alternating sand/gravel bars can redirect flow from parallel to impinging, and there can be failures of RSP revetments that were designed and built for parallel flow.

7. In Caltrans with limited staff and recently revised policy, there are fewer quality-control tests of materials and fewer field inspections. Consistent with decreased testing are failures like the one at Grizzly Creek (site 60 in Table 7-2). On that job and others, RSP-fabric was accepted that was certified as woven monofilament, when in fact it was actually a *woven-tape* (also called *slit-film*). Woven-tape geotextiles do not pass large quantities of water perpendicular to the plane of the fabric. They have low values of **permeability** on the order of 0.10 per second or less (305 liters per minute per square meter, 7.5 gallons per minute per square foot) according to ASTM test method 4491. Woven tapes with low permeabilities also have low values of percent open area, on the order of two percent or less. Water can get trapped in bank soils behind woven-tapes with low permeabilities. When the stage drops rapidly, trapped water does not flow back into the channel quickly enough, and the woven-tape and riprap collapse into the channel.

Based on failures similar to Grizzly Creek, without site inspections and relying on hearsay, it is erroneously presumed that geotextiles do not work. The appropriate conclusion is that similar failures can be avoided by specifying and assuring RSP-fabrics that have a reasonably high minimum permittivity. Using high permittivity RSP-fabrics will minimize the possibility of such failures. Reasonably high permittivity values for RSP-fabrics are on the order of 0.5 per second or more (1525 liters per minute per square meter, 37.5 gallons per minute per square foot). See Recommendation 5, next chapter.

8. The existing Caltrans Standard Plan B-13-2 in Reference 48, (Caltrans, *Standard Plans*), is not adequate for river or stream banks and for lake or ocean shore protection, because it does not show layers. **Standard construction details** for use on Caltrans contracts need to be developed according to the layered design procedure in Chapter 5.

Figure 153 in Reference 1, (CA Division of Highways, 1970 edition) is a useful guide for developing standard construction details of layered RSP. Additionally, Figure 873.3C in Reference 46 (Caltrans, *Highway Design Manual*), shows several good features for designing RSP. Both figures have notes for designers of RSP, and they need some modifications to conform with recommendations of this report. While such drawings and notes are useful to designers, a separate set of drawings and notes is needed by builders of RSP and inspectors. Recommendation 4 in the next chapter outlines features that should be included in standard construction details.

9. There is a note on Figure 153 in Reference 1 that reads: "Face stone Voids should be filled with smaller rock." Filling or "chinking-the-voids" was intended to produce a smooth hydraulic surface and help interlock the rocks of the outside layer. In California this practice is outdated and should normally not be done. As confirmed by field evaluations in Table 7-2 of this report, small rock in the outside layer of RSP is very loosely held and typically does not interlock well. Small rocks are ultimately washed out of the revetment by impinging flow or during rapidly receding stages. Filling voids in the outside layer with quarry run material is also expensive, especially if rock is measured and paid by weight and not by volume. For most situations, it is preferred to have a rough outside layer of RSP, thereby producing a surface that enhances the opportunity for establishing diverse habitat conditions, and ultimately appears nearly natural. A roughened surface (scalloped irregular margin between water and RSP in plan view) dissipates stream energy, promotes oxygenation, provides resting eddies for migratory and resident fish, and leaves voids to capture suspended sediment and

fragments of woody debris as flood waters recede. Over time, naturally occurring or planted vegetation grows in soil-filled voids. Vegetation provides shaded riverine aquatic cover and habitat for riparian dependent wildlife species.

10. Where there was riparian vegetation before a bank failure, filling voids with soil and planting is justified as "replacement in kind". Until vegetation is re-established, local ground and water temperatures are higher. For compliance with some regulatory permits, revegetating on top of and among RSP is done as mitigation to encourage riparian habitat where there may have been little or no prior growth.

Hydraulic analysis of the site is required to determine the feasibility, economics, and elevation limits of revegetation efforts. Without hydraulic data, simply filling surface voids and placing a lift of soil over RSP down to the elevation of the dry-period water level (below "normal high water") is costly and not good practice. During high-water stages, loose soil may erode and contaminate the water and streambed with sediment. Revegetation efforts are often successful above the stage of "normal high water" or even higher, although vegetation in these locations needs to be selected based on the drier upslope conditions. Some silty soils have strong capillary action and draw water to elevations higher than sandy soils. Long-term success or failure depends on the frequency, duration, and energy of overtopping river stage events. The proximity (elevation-wise) to water is critical to vegetation during prolonged dry spells, that is, plants higher up the bank dry-out and die unless they are irrigated. Recently planted immature vegetation, along with irrigation pipes or drip tubes and fixtures may be swept downstream during a flood.

When vegetation is planted on streambanks, there is increased resistance to high water stages as vegetation matures. Retarding velocity along banks is beneficial, because erosive forces of water are dissipated. However in narrow reaches, with decreased velocity and flow rate, there may be a backwater effect that causes upstream flooding. An optimum vegetation mix can flex, retard current, and allow water to pass without significantly decreasing channel capacity. Where limited hydraulic resistance is desired, a species like sand bar willow (*Salix exigua*) can be planted, because like most willow species, it bends under the strain of swiftly flowing water.

Managing vegetation on banks of flood control levees varies from doing nothing to removing stiff cane-like plants (dead blackberry canes) or trees that are larger than a specified diameter at breast height ("dbh"). Tall trees with shallow and spreading root systems can be toppled by the combined effect of strong winds and swift river currents.

A toppled tree can produce a large areal void in the bank, where there is potential for a future breach. There have been incidents (in WA) where toppled trees were conveyed downstream, impinged directly on a levee bank, and punched holes through thin RSP sections. Before any repairs could be done, the softer materials eroded and the levee breached. In some locations local Corps of Engineers districts and/or flood control agencies can require specific practices, like removing dead trees and certain sizes of vegetation, because those practices assure that design floods will pass without incident to life or property. Managing vegetation is paid for by landowners, whose lives, livestock, and properties are protected from floods.

In certain locations, especially portions of CA where there is salmonid and/or anadromous fish habitat, no woody materials are removed from streambanks or within streams. On stream restoration projects that use biotechnical techniques, and where cut logs and root wads are designed in conjunction with RSP, woody materials are secured to (or within) the bank, so they do not become hazards farther downstream during high water events.

3. Recommendations

1. The California Bank and Shore (CABS) layered RSP design procedure is recommended for designing riprapped bank and shore protection facilities on Caltrans projects. The recommendation is based on the authors critically field evaluating nine CABS RSP sites in Table 7-2 and reviewing written reports of more than 151 additional CABS RSP sites in CA. The 151 or more RSP sites were reported to us by Caltrans maintenance engineers and crews, who are familiar with problems along roads in their purview. Most RSP facilities were reported as "successful" according to the criteria of Exhibit 6-A. Less than 10 percent "failed and needed repair", usually due to design criteria being exceeded during floods of 1964 and 1986. Maintenance Engineers and numerous crews from Districts 1, 2, 3, 4, 9, and 10 responded with written reports covering 30 California counties: Del Norte, Humboldt, Mendocino, Lake, Siskiyou, Trinity, Lassen, Plumas, Tehama, Butte, Glenn, Sacramento, Yolo, Yuba, Sierra, Nevada, Placer, El Dorado, Sonoma, Marin, Santa Clara, Contra Costa, Alameda, Mono, Inyo, Kern, Mariposa, Calaveras, Amador, and Alpine. Other Caltrans districts responded by phone to our inquiry (Exhibit 6-A), and like the majority of written reports, more sites were successful than failed.

The ***CABS layered RSP design method*** is presented in Chapter 5, Sections 5-1 and 5-2. Engineering judgment tempered with experience should be used to verify results of standard CABS layered designs. Other RSP design methods may be applied to verify results or to alter rock sizes, when the engineer has sufficient site information and experience with other design methods.

2. A field investigation is strongly recommended. Bank toe scour and streambed scour problems might be due to ongoing natural changes of the stream. Thalweg migration and head-cutting can result from unnatural changes, like scour below dams or in-stream aggregate mining operations. Channel in-filling can be the result of damaged watersheds. Stream morphology can be studied by comparing time sequenced aerial photographs along with ground surveys. Data on recent significant storm events can be obtained by interviewing local residents, flood control agencies, or anyone who might have photographs or videotaped recordings. When observations are taken during storms, personal safety is always the highest priority. For river or stream bank protection, the engineer must obtain observations or data on high water stage, velocity, stream geometry, channel stability, and changes in stream morphology. For ocean shore protection, the engineer must obtain observations or data of: wave height and angle of attack, wind speeds and directions, ocean currents, scour and deposition

along the beach, debris deposits in the littoral zone (between high and low tides), and historical high and low tide elevations. Section 5-2 identifies sources of some data needed for designing RSP shore protection facilities.

3. In order for designers to enhance their experience with RSP facilities, periodic field reviews using as-built plans and photographic records are recommended. Fact sheets with updated photographs of old sites, and of sites with new (experimental) features, can then be assessed more accurately.

Field inspections are recommended at "successful" and "failed" RSP facilities. The inspection team should include a hydraulic and a geotechnical engineer. An engineer who is experienced in RSP design is probably sufficient. A fact sheet like the "data guide" of Table 6-1 should be used to record periodic assessments of RSP facilities and their corresponding design methods. Fact sheets for each site can then be synthesized and presented similar to Table 7-2.

4. Caltrans should develop standard construction details of layered RSP for river or stream banks and lake or ocean shores. Drawings and notes should be directed to construction people, specifically contractor's field crews who build RSP revetments and construction inspectors. Construction drawings and notes do not need generic design data. Designers should be able to retrieve drawings from data storage media via personal computers, networks, or mainframe systems.

One standard construction detail should show **RSP-fabric (not filter fabric)** in a cross sectional view as the initial filter-separator material. For example, see Figure A-1 in Appendix A. Standard details should be available that show one or more layers of RSP, based on data in Tables 5-1, 5-2, and 5-3. Other drawings to include are:

- a. flank details for beginning and ending the RSP revetment,
- b. layered cross-sections of RSP with RSP-fabric,
- c. alternate toes, which accommodate scour and undermining below the elevation of the existing streambed, and
- d. *windrow RSP*.

Windrow RSP is rock placed along the top of a bank where water levels, bank heights, and/or right-of-way make backslope preparation not possible or too expensive. The windrow of graded rock parallels the river alignment along the eroding bank, so that as the toe scours and the bank-face sloughs, windrow rock launches and falls into the scoured zones. Reference 58 documents a successful field study by the Omaha District of the US Army Corps of Engineers along the Missouri River near Vermillion,

Nebraska. For guidance on windrow dimensions, use Reference 4 (June 1994 edition, section 3-11 "d. Method D"), which is based on work by Dr. Stephen T. Maynard. On Caltrans projects, percent ranges of windrow rock gradations should be similar to the percent ranges specified for Site 59, the Mad River project, (see Table 7-2), but rock sizes must be selected on a site-specific basis.

5. Most woven-tape geotextiles (slit-films) are not acceptable as RSP-fabrics, because they have low permittivities, that is, they do not allow water to flow through rapidly, perpendicular to the plane of the fabric. An exception is the fibrillated woven tape, a recent development in geotextiles, in which tapes of one or both directions of the weave are sliced very finely to produce higher permittivity.

Whether an RSP-fabric is made of woven monofilament, fibrillated woven tapes and non-fibrillated tapes, or needle-formed nonwoven "felt" materials, the recommended minimum permittivity of an RSP-fabric is 0.5 per second (ASTM test method D 4491). Construction resident engineers should **require test data** to assure that RSP-fabrics have a permittivity greater than 0.5/second. Most nonwoven needle-formed geotextiles have permittivities greater than 0.5/second. There are a few fibrillated woven tapes and woven monofilaments that have permittivities greater than 0.5/second that are acceptable as RSP-fabrics. Until section 88-1.04 of the Caltrans *Standard Specifications* is updated, include the minimum permittivity addendum to standard special provision (SSP) 72.15 shown on page B-10 of Appendix B. Also on page B-10, the instructions for SSP 72.15 were modified for when to use Type B RSP-fabric; for clarification see Table 5-2.

6. Table 7-2 in this report documents RSP site failures, which were either entirely or partially attributed to not having filter layers or RSP-fabric. If planting is required on the revetment, RSP-fabric can be slit for deeply rooting species. However, slitting RSP-fabric **below** the elevation of "normal high water" or "average seasonal high water" is **not recommended**. With cyclic rising and falling stream stages, soil particles will pipe through slitted RSP-fabric, leaving voids and compromising the rest of the slope. An alternative material for RSP-fabric is Backing No. 3, see Table 5-1. Root development will spread throughout and penetrate Backing No. 3. See Appendix A, Figure A-4.
7. The outer layer of RSP should have a rough surface. The 1995 Caltrans metricated *Standard Specifications* allow a tolerance of 0.30 meter, plus or minus, of the design surface. Consideration should be given to allowing surfaces which have tolerances

greater than 0.30 meter, as long as stream capacity is not reduced. For designs that vary from the standard 0.30 meter tolerance for rock surface roughness, hydraulic calculations may need to be done with appropriate roughness coefficients, to determine the possibility of reduced flow rates, velocity changes, local scour potential, or higher stages.

8. Proposals to place soil and plant materials on RSP revetments should be reviewed by a hydraulic engineer, who can provide stream stages and verify that appropriate roughness factors are used in the hydraulic analysis. Mature vegetation can reduce the rate of flow through a reach in narrow streams, and the resulting backwater effect can cause upstream flooding. Adding soil cover should be done with permit agency approval, because of the potential of degrading water quality:

- by increasing turbidity during flood stages, and

- by depositing suspended sediments in the streambed as water stage drops.

Depth of soil cover should be the minimum required to fill rock voids and to support species that will be planted. Too much soil, especially on riprapped slopes steeper than 1V:2H, tends to slough when saturated.

9. Recommendations and other portions of this report should be used to guide future modifications of the 1995 or subsequent editions of Reference 46 (*Caltrans Highway Design Manual*). Various topics which should be modified under Section 873.3 Armor Protection are: "Flexible Revetments," "Streambank Protection," "Rock Slope Protection Fabric", and "Streambank Protection Design - Stone Size."

4. Implementation

1. The California Bank and Shore method of RSP design has been used with a variety of interpretations by engineers in Caltrans and elsewhere since about the early 1960's. The **CABS layered RSP design method** is clarified in Chapter 5 and has been used and critiqued on a project-by-project basis by Caltrans designers since 1989. This report replaces a monograph by Racin dated 1989 or later called:

LAYERED ROCK SLOPE PROTECTION (RSP) WITH RSP-FABRIC.

The monograph was an interim document that shaped Chapter 5.

2. The authors will send copies of this report to the Federal Highway Administration and Caltrans engineers and staff in hydraulics, materials, geotechnical, and project development. Engineers, biologists, and designers in several other agencies will also receive copies of the report. Because some districts frequently reassign the position of hydraulic engineer, the report will be available at future Caltrans Hydraulic Engineers meetings. About one year from the date of publication, it should also be available through the NTIS. See the technical report cover page for the address. The Chapter 5 procedure and example problems will be made available via the Caltrans web site.
3. **REQUEST FOR READER RESPONSE.** If there are maintenance activities, failures, or reconstruction contracts at any RSP sites listed in Table 7-2, please notify the principal author:

James A. Racin, P.E.
Caltrans Office of State Highway Drainage Design
Mail Station 28
PO Box 942874
Sacramento CA 94274-0001
phone 916-651-6550
fax 916-653-1446
Internet e-mail Jim_Racin@dot.ca.gov

Alternatively, please notify individuals who participated in the Table 7-2 site evaluations. They are listed in bold print as "field reviewers" in Chapter 9 "Personal Communications". The information you provide can be valuable for updating or changing aspects of RSP design and construction methodology.

4. Any proposed changes to the standard California Bank and Shore layered RSP design method or standard construction details are normally reviewed by the Bank and Shore Protection Committee for possible approval. Proposed changes must be supported with case-history information on RSP facilities. The committee also routinely offers help for RSP problem sites and relies on the experience and consulting support of hydraulic engineers from Structure Hydraulics in Sacramento and the Caltrans Districts. As of October 2000 the committee members and the Caltrans Offices where they work are:

Glenn DeCou, Chairman	State and Local Highway Drainage Design
Paul Askelson	Structure Maintenance and Investigations
Joseph Dobrowolski	Construction
John Rizzardo	Maintenance
Gary Garofalo	Roadway Geotechnical Engineering

5. As of October 2000, the authors have not written nor collaborated in writing any computer programs that generate designs by the California Bank and Shore layered RSP method according to Chapter 5. Anyone executing software that uses (or will use) the California rock-sizing equations should confirm that the results recommend **layered designs** comparable to those shown in Chapter 5 and the examples in Appendix A. If there are technical RSP design questions, (no computer hardware or software questions please), then contact James A. Racin or any other member of the Bank and Shore Protection Committee.
6. This report is being used to guide revisions and clarify various sections of the Caltrans *Highway Design Manual*, Section 873.3, Armor Protection: "Flexible Revetments," "Streambank Protection," "Rock Slope Protection Fabric," and "Streambank Protection Design - Stone Size." Also, for consistency, changes will be proposed to the Caltrans *Standard Specifications* via Standard Special Provisions. Likewise, "standard plans" will be proposed via standard construction details.

5. California Layered RSP Design Method

This chapter clarifies several aspects of the California Bank and Shore layered RSP design method, especially for river and stream bank protection. Interviews with design, construction, and maintenance engineers indicate that designing and constructing **layers** of rock is normal practice for both river bank and ocean shore protection. *Omitting layers is for exceptional cases:* when it is unavoidable during "flood fight," when the backslope material is rocky, when the facility is temporary, or when alternative materials like gabions are used for the inner layers, see Reference 49 (Racin).

Designing layers of RSP for stream and river banks is similar for ocean and lake shores. The difference is in the equations for determining minimum stable rock size of the outside layer. Section 5-1 presents the equation, a standard procedure, and detailed discussions for designing RSP on river and stream banks. Appendix A has sample problems, solutions, and problem-specific cross section views that demonstrate the procedure of Section 5-1. Although the examples are hypothetical, they are based on practical experience, which includes more than the nine sites field-reviewed in Table 7-2. Ocean shore field evaluations were done in this study, but the focus was on river and stream banks. Section 5-2 shows two rock sizing equations for the outside layer of ocean shore RSP with only a brief discussion of design procedure. The reader is directed to references with detailed presentations. Recent Internet addresses are listed in Section 5-2 as possible sources of data: ocean and lake levels, tides, wave heights, winds, currents, etc.

Standard **rock size** is called **rock mass** in Reference 47 (Caltrans, *Standard Specifications*, 1995 edition) and in this report, rock **size**, **weight**, and **mass** are often used interchangeably.

In this report, rock sizing equations are given in US customary units, for ease of reviewing and cross-referencing other literature.

5-1 Procedure for Designing Layered RSP on Banks of Rivers and Streams

5-1-A. Collect River/Stream Data. Data are needed to determine average stream velocity and whether the stream is flowing parallel-to or impinging-on the banks. Obtain records of flow rates, velocities, and stages, or estimate values and try to field-verify them (next step). Obtain ground and aerial photographs, maps, and as-built contract plans of existing, adjacent, and nearby bank protection, which have RSP or alternative revetment materials.

5-1-B. Inspect Site. A field visit to the site is required. Determine the site hydrology, existing slope angles and bank soil types, presence of springs and seeps, and what materials and conditions are likely for imported borrow. Estimate channel and nearby bank roughness and note the roadway alignment in relation to the stream. Confirm the direction of flow, angles of stream flow at various stages (flow depths), and flow rate and velocity estimates which were made in section 5-1-A. Obtain stream cross sections, where and when feasible, to verify flow rates and velocities at various stages.

Interview local maintenance people and residents. Try to determine the number of events which overtopped banks and the stages which may have flooded roads and properties. Obtain information on the extent of damages and any temporary repairs made during flood fight. Temporary repairs might have to be reconstructed. If there are no previous data, then consider starting an RSP inventory. Table 6-1 lists data to consider in site inventories, and Table 7-2 is a condensed format to assess sites and design methods for future evaluations. Data on nearby RSP sites is useful; those sites should be field-reviewed and reevaluated after significant events. Consult with a geotechnical engineer about slope stability.

Contact wardens, in-house and outside agency biologists, and engineers of agencies that require permits or agreements: Fish and Game, Corps of Engineers, Fish and Wildlife Service, National Marine Fisheries Service, Coastal Zone Agencies and Commissions, State and National Park Departments, and Resource Conservation Districts. Additional considerations include: fish passage, fish habitat, restricted times to work due to life cycles of local biota ("construction windows"), wild and scenic river reviews, endangered plant or animal species, revegetation requirements, and aesthetics. This is not complete list of considerations due to diversity among sites.

5-1-C. Determine Minimum Stone Weight. Solve Equation 1 for W in US customary units. To get values in System International (SI), metric units, first divide the weight of minimum stable rock, W in pounds by 2.2 to get W in kilograms, then divide by 1000 to get W in tonnes. Use W later in section 5-1-D. See Figure 5-1 for key variables in Equation 1.

Equation 1.
$$W = \frac{0.00002 V^6 SG}{(SG - 1)^3 \sin^3 (r - a)}$$

W = theoretical **minimum rock mass (size or weight)** which resists forces of flowing water and remains stable on slope of stream or river bank, POUNDS.

V = velocity to which bank is exposed, FEET PER SECOND.

for PARALLEL flow multiply average channel velocity VM by 0.67 (2/3)

for IMPINGING flow multiply average channel velocity VM by 1.33 (4/3)

SG = specific gravity of the rock.

r = 70 DEGREES (for randomly placed rubble, a constant).

a = outside slope face angle with horizontal, DEGREES.

In profile, the lower elevation limit of riverbank RSP is based on expected scour (determined by experience, measurements, or scour equations). The upper elevation limit is based on design high water, although it may be set higher.

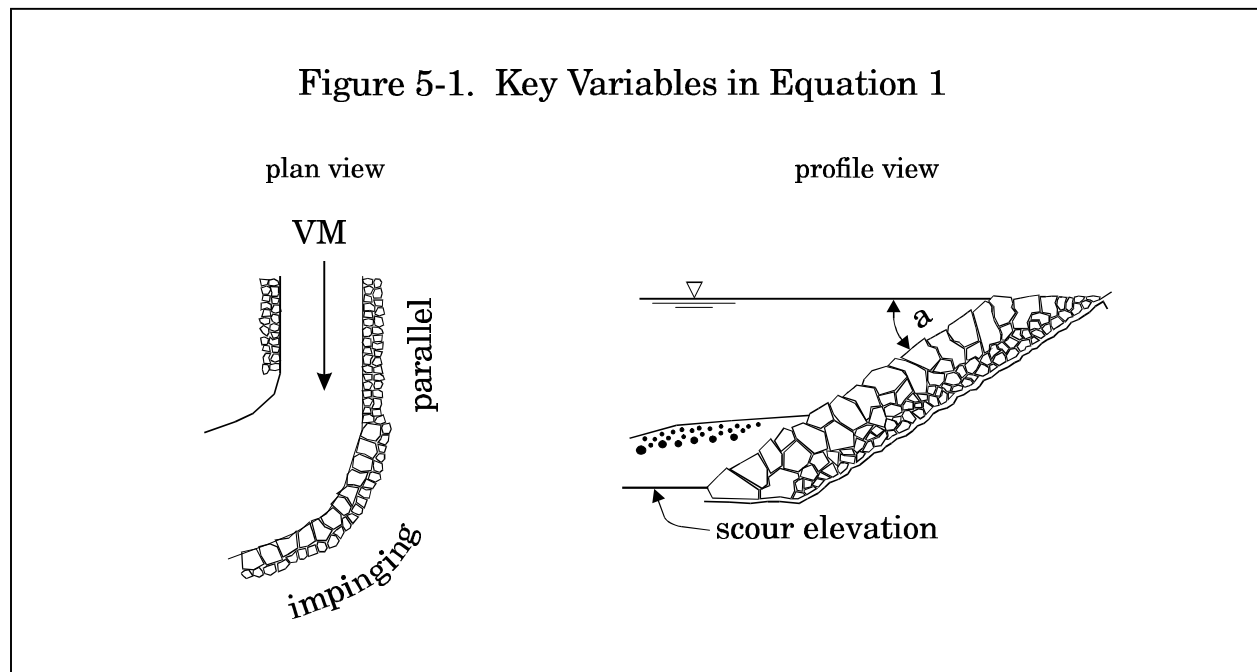

Review the inputs of Equation 1. Was average stream velocity decreased for parallel flow or increased for impinging flow? Estimate whether parallel flow is likely to persist in the future. Do not arbitrarily raise velocities to higher values, because Equation 1 is very sensitive to velocity. If you must be conservative, wait until section 5-1-D, where you select the outside layer RSP-Class. For preliminary calculations, use 2.65 as the value of specific gravity. Consult with a materials engineer and determine likely sources of rock and values of specific gravity, which are based on material tests. In California practice, the minimum specific gravity is 2.50. Other required rock properties and tests are shown in Appendix B page B-2, a copy of section 72-2.02 of the 1995 Caltrans *Standard Specifications*. Additional requirements or rock property tests are normally not required by Caltrans, according to research in Reference 29 (Gamble and Mearns, out-of-print).

A guideline for the maximum outside slope face angle of the RSP with the horizontal is 33.69 degrees, that is, 1.0 vertical to 1.5 horizontal (1V:1.5H). The outside layer of rocks must interlock and must be stable in flowing water. The underlying bank must be stable during construction, therefore consult with a geotechnical engineer and confirm that the proposed angle of the underlying bank slope is acceptable. The outside slope face and underlying bank slope angles do not necessarily have to be the same.

5-1-D. Determine RSP-Class of Outside Layer. With W in metric units, determine the RSP-Class of the outside layer of the revetment using Table 5-1.

Before proceeding, an explanation of the Caltrans standard RSP gradations and terminology is needed. For this discussion see Table 5-1, which is similar to page 72-1 Section 72-2.02 Materials of the 1995 Caltrans *Standard Specifications*. All the standard gradations are named **RSP-Classes**. Table 5-1 is divided into two sections with a bold dashed vertical line, which separates two construction methods of placing rock. "Method A" is for larger RSP-Classes, and "Method B" is for smaller RSP-Classes. Column headings listed immediately above the bold horizontal line are SI (metric) **names** of RSP-Classes, and US Customary names are listed above the SI (metric) names. RSP-Classes are used on typical cross sections and plans and pay item descriptions in the engineer's estimate. In SI (metric) units they are: *8T, 4T, 2T, 1T, 1/2T, 1/4T, Light, Facing, Backing No. 1, Backing No. 2, and Backing No. 3.*

The label for each horizontal row is a STANDARD Rock SIZE or Rock Mass or Rock WEIGHT. To clarify that they are row labels, the STANDARD Rock SIZES are

GRADING OF ROCK SLOPE PROTECTION PERCENTAGE LARGER THAN

STANDARD Rock SIZE or Rock MASS or Rock WEIGHT		RSP-Classes [A]											
		Method A Placement					Method B Placement						
		RSP-Classes other than Backing									Backing No.		
		8 ton	4 ton	2 ton	1 ton	1/2 ton	1 ton	1/2 ton	1/4 ton	Light	1 [B]	2	3
US unit		8 T	4 T	2 T	1 T	1/2 T	1 T	1/2 T	1/4 T	Light	1 [B]	2	3
SI unit													
16 ton	14.5 tonne	0-5											
8 ton	7.25 tonne	50-100	0-5										
4 ton	3.6 tonne	95-100	50-100	0-5									
2 ton	1.8 tonne		95-100	50-100	0-5		0-5						
1 ton	900 kg			95-100	50-100	0-5	50-100	0-5					
1/2 ton	450 kg				95-100	50-100	-----	50-100	0-5				
1/4 ton	220 kg					95-100	95-100	-----	50-100	0-5			
200 lb	90 kg							95-100	-----	50-100	0-5		
75 lb	34 kg								95-100	-----	50-100	0-5	
25 lb	11 kg									95-100	90-100	25-75	0-5
5 lb	2.2 kg											90-100	25-75
1 lb	0.4 kg												90-100

[A] US customary names (units) of RSP-Classes listed above SI names, example US is "2 ton" metric is "2 T".

[B] "Facing" has same gradation as "Backing No. 1". To conserve space "Facing" is not shown .

Example for determining RSP-Class of outside layer. By using Equation 1, if the calculated W=135 kg (minimum stable rock size):

1. Enter table at left and select closest value of STANDARD Rock SIZE which is greater than calculated W, in this case 220 kg
2. Trace to right and locate "50-100" entry 3. Trace upward and read column heading "1/4 T", then 1/4 T is first trial RSP-Class.

Table 5-1. Guide for Determining RSP-Class of Outside Layer

separated from the gradations by a bold vertical line. Almost all RSP-Classes are named by the "50-100" percent STANDARD Rock SIZE, also called **W50**.

The gradations in Table 5-1 were adopted by the California Division of Highways in the late 1950's; they are similar to gradations which were recommended by AASHTO (American Association of State Highway Officials). Although the table is labeled in bold print as **PERCENTAGE LARGER THAN**, gradations are sometimes misquoted as percentage passing or percentage smaller than. To help understand the table, look at *METHOD A Placement, 1T RSP-Class*. "95-100" percent means nearly all the rocks are heavier than 450 kg and lighter than 1.8 tonne, the maximum STANDARD Rock SIZE of the *1T RSP-Class*. The "95" allows 5 percent of the rocks to be lighter than 450 kg, for breakage during production at the quarry, transport, or placement at the site. "50-100" percent means at least half the individual rocks must be heavier than 900 kg and lighter than 1.8 tonne. "0-5" allows 5 percent of the rocks to be heavier than 1.8 tonne, and with the slope tolerance dimension of 300 mm, not too many out-of-spec oversized rocks should show up on a job. Nowhere in the table or footnote does it say that "all rocks must be the same weight as the 50-100 standard rock weight."

Sometimes quarries produce what is called "Caltrans spec rock." That is, each rock is nearly the same size as the "50-100" percent standard rock size (**W50**) of the RSP-Class, such that there is no visible range of rock sizes. Table 5-1 does not clearly exclude same-sized rocks in an RSP-Class. When a quarry consistently produces nearly same-sized rocks for standard RSP-Classes, consider multiplying the **D50** by 2 (effective diameter of the "50-100" percent standard rock size of the RSP-Class), for minimum layer thickness. This assures adequate rock interlock, which is required for a stable RSP facility. Section 5-1-F presents more information about thickness.

To determine the RSP-Class of the outside layer, enter Table 5-1 at the left. Select the closest STANDARD Rock SIZE greater than W, the minimum rock weight calculated in section 5-1-C. Trace horizontally to the right and find the "50-100" (or "25-75") table entry. Finally, trace upward vertically to the column heading and simply read the RSP-Class. Use this as the "first trial" RSP-Class of the outside layer of bank protection; it may also become the "final selection."

With historical, site-specific knowledge and engineering judgment of existing and expected field conditions, decide whether the "first trial" RSP-Class should be lighter or heavier for the "final selection." Some considerations are:

1. Rocks lighter than 90 kilograms can be moved by recreational users. There have

been reports of rocks being stolen and used in home landscaping projects. Therefore, if the project is in a populated area or where there is high recreational use, and if Equation 1 ultimately gives an RSP-Class smaller than *Light* for the outside layer, then consider specifying *Light*.

2. If sections of RSP have sloughed into the river where the road closely follows the river, check design notes and nearby RSP site histories, which might reveal that parallel flow was assumed. By field-reviewing the site at low and moderate stages, you may note meandering flows that impinge and attack the toe of RSP. Meanders can be caused by migrating gravel bars and deposited debris during floods. Recalculate the minimum W in Equation 1 using an impinging velocity, determine the RSP-Class of the outside layer, and compare it to the existing RSP-Class. Consider a heavier Class or extending the toe of the revetment.

5-1-E. Determine the Required Layers of RSP. Inexperienced designers sometimes use Table 5-1 and specify all the RSP-Classes between the "final selection" outside RSP layer and Backing No. 3. To avoid this pitfall, use Table 5-2, **California Layered RSP**. Standard designs include RSP-fabric, Backing Class, Inner, and Outside layers of RSP as shown. Table 5-2 is based on Equation 1, section 5-1-C on page 23. It's the same equation (and nomograph solution) in Figure 873.3A of Reference 46 (Caltrans, *Highway Design Manual*). If Table 873.3B is used to check the design, then you must include layers of RSP according to the method described herein. Do not arbitrarily eliminate **inner layers** to reduce thickness. In Table 5-2, in conformance with filtration theory, from the bank to the stream, each layer was designed progressively larger, so an inner layer will not pass through voids of the next layer. The thickness of the entire cross section is reduced and less costly when RSP-fabric replaces Backing No. 3. Do not arbitrarily eliminate RSP-fabric. If you do not use RSP-fabric, then 230 mm of *Backing No. 3* is normally required as the initial "filter-separator" layer, and it is placed directly on the bank to be protected. If *Backing No. 3* is rounded, river-run material, then the steepest allowable slope angle should be 1V:2.5H, contrary to the recommended 1V:2H of the Caltrans *Standard Specifications*.

An example using RSP-fabric is: *Type B RSP-fabric* is placed directly on the bank as the initial "filter-separator" material, the inner layer is *Light*, and the outside layer is *1T*. Notice that in Table 5-2, when the outside layer is *1T* or larger there is more than one possible design for inner layers. Each design satisfies filtration theory, that is, underlying layers are retained. Rock availability and/or cost of producing one design versus another may determine which RSP-classes are selected as inner layers. Or on another part of a project there may already be a specified inner RSP-class, and rather than introducing another inner RSP-class, use the one that is already specified.

Table 5-2. California Layered RSP SI metric (US customary values shown for OUTSIDE LAYER only)			
OUTSIDE LAYER RSP-CLASS *	INNER LAYERS RSP-CLASS *	BACKING CLASS No. *	RSP-FABRIC TYPE **
8 T (8 ton)	2 T over 1/2 T	1	B
8 T (8 ton)	1 T over 1/4 T	1 or 2	B
4 T (4 ton)	1/2 T	1	B
4 T (4 ton)	1 T over 1/4 T	1 or 2	B
2 T (2 ton)	1/2 T	1	B
2 T (2 ton)	1/4 T	1 or 2	B
1 T (1 ton)	LIGHT	NONE	B
1 T (1 ton)	1/4 T	1 or 2	B
1/2 T (1/2 ton)	NONE	1	B
1/4 T (1/4 ton)	NONE	1 or 2	A
LIGHT (LIGHT)	NONE	NONE	A
Backing No. 1*** (Backing No. 1)	NONE	NONE	A

* Rock grading and quality requirements per Section 72-2.02 Materials of the Caltrans *Standard Specifications*. (See Appendix B).

** RSP-fabric Type of geotextile and quality requirements per Section 88-1.04 Rock Slope Protection Fabric of the Caltrans *Standard Specifications*. (See Appendix B). Type A RSP-fabric has lighter mass per unit area and it also has lower toughness (tensile x elongation, both at break) than Type B RSP-fabric. Both types require minimum permittivity of 0.5 per second.

*** "Facing" RSP-Class has same gradation as Backing No. 1.

Material property values were selected for the RSP-fabric in Section 88-1.04 of the Caltrans *Standard Specifications*, by assuming that construction inspectors will limit the maximum height of rockfall during placement to about 1 meter. End dumping of rock down embankments is not recommended, because rocks will damage and dislodge the RSP-fabric and the rock sizes will segregate.

A layer of *Backing No. 1* or *No. 2* is the first layer of rock, which is placed directly on RSP-fabric, unless there is only *Light* or *Facing*. Backing keeps the RSP-fabric in contact with bank soil, thereby preventing soil movement and loss of fines by piping and erosion through overlapped RSP-fabric, which can ultimately lead to failure. *Light* or *Facing* is the largest RSP-Class which should be placed directly on RSP-fabrics. When the revetment cross section includes RSP-Classes greater than *Light*, inner layers of RSP are required. When the cross section of the revetment includes any RSP-Class greater than $1/4 T$, then *TYPE B RSP-fabric* is required. Placing a layer of sand to protect RSP-fabric from damage is normally not needed. Caltrans specifies RSP-fabrics to be tough enough to withstand normal construction practices like rockfall of 1 meter or less.

5-1-F. Determine the Thickness of the RSP Revetment. First determine t , the minimum layer thickness. Sum each minimum layer thickness to get the **total** thickness of the revetment. In the Engineer's estimate, for each RSP-Class, a method of placement is specified: either Method A or Method B. Typically, Method A is used for large RSP-Classes, which require individual placement by equipment to achieve "3-point bearing" (no wobbling) on adjacent rocks. Method B, also called "dumped RSP" does not mean that rock can be dumped from the top to the bottom of long embankments. Placing rock by Method B means that rock is dumped near its planned location, then machinery works the rock to its final position. When feasible, work normally progresses from lower to higher elevations to control thickness and size segregation.

Table 5-3 provides guidance for the minimum layer thickness. First an effective diameter **D50** was calculated with assumptions: specific gravity is 2.65 and rock shape factor is spherical. This does not mean the rocks are actually spheres. Use the formula for the volume of a sphere to calculate **D50**, but first select **W50**, the "50-100" percent standard rock weight and use the "definition" formula, Volume is Weight divided by Specific Weight. In US customary units:

$$\text{cubic feet} = \text{pounds} / [(62.4 \text{ pounds} / \text{cubic foot}) \times \text{specific gravity}].$$

For Method A placement, the resulting **D50's** were multiplied by 1.5, which is a reasonable value to assure interlock of rocks within the same layer, and for interlock with subsequent layers. For Method B Classes *Backing No. 1* through *1T*, the **D50's** were multiplied by 1.875. The 25 percent increase accounts for looser placement by spreading and for placing in flowing water. The factors 1.5 and 1.875 are empirical and usually have worked well in CA. Local experience or data of flume studies could support factors other than 1.5 or 1.875 for layer thicknesses on a particular job.

Table 5-3. Minimum Layer Thickness SI metric (US customary)		
RSP-Class Layer	Method of Placement	Minimum Thickness
8 T (8 ton)	A	2.60 meters (8.5 feet)
4 T (4 ton)	A	2.07 meters (6.8 feet)
2 T (2 ton)	A	1.65 meters (5.4 feet)
1 T (1 ton)	A	1.31 meters (4.3 feet)
1/2 T (1/2 ton)	A	1.04 meters (3.4 feet)
1 T (1 ton)	B	1.65 meters (5.4 feet)
1/2 T (1/2 ton)	B	1.31 meters (4.3 feet)
1/4 T (1/4 ton)	B	1.00 meters (3.3 feet)
Light	B	760 millimeters (2.5 feet)
Facing	B	550 millimeters (1.8 feet)
Backing No. 1	B	550 millimeters (1.8 feet)
Backing No. 2	B	380 millimeters (1.25 feet)
Backing No. 3	B	230 millimeters (0.75 feet)

For total thickness, add each layer thickness. Use zero thickness for the RSP-fabric. Before adopting values in Table 5-3, consult with a materials engineer about rock sources, quality, shapes, and specific gravity. Calculate new thickness values if the shape factor is not spherical and specific gravity is not reasonably close to 2.65. "Minimum Thickness" values were calculated by starting with US customary units, hard-converting to a value in feet, then soft-converting to SI metric values.

5-1-G. Review Hydraulic Calculations at Site With RSP and Possibility of Vegetation. This step of the layered design process is required to help assure future success of the revetment under changed channel dimensions, roughness coefficients, and other permit/agreement requirements. Examples are: filling voids among RSP with soil and/or covering RSP with soil then planting local species, and/or enhancing fish habitat by placing large-sized rock along the toe. Discuss site hydraulics with people of permit agencies and feasible revegetation efforts. Historically, sites with no prior vegetation are usually not revegetated, especially when subjected to scouring velocities or high wave attack.

5-2. Rock Sizing Equations for Ocean Shore Protection and Data Sources

5-2-A. Shoal Water and Deep Water Equations. For ocean shore protection two rock sizing equations are Equation 2 for shoal (shallow) water and Equation 3 for deep water, both from Reference 1 (CA Division of Highways). As with Equation 1, US customary units are used. For TONNES multiply TONS by 0.9072, and for KILOGRAMS multiply TONNES by 1000. Figure 5-2 shows key variables in Equations 2 and 3.

$$\text{Equation 2. } W = \frac{0.003 \text{ dB}^3 \text{ SGR}}{[(\text{SGR} / \text{SGW}) - 1]^3 \text{ SIN}^3 (r - a)}$$

W = theoretical **minimum rock mass (size or weight)** which resists shoal water wave forces and remains in the revetment, TONS.

dB = depth of scour below mean sea level plus 1/2 maximum tidal range, FEET.

Generally for lakes, dB is difference between scour line elevation at toe and maximum still water elevation.

SGR = specific gravity of the rock.

SGW = specific gravity of seawater, use 1.0265

r = 70 DEGREES (for randomly placed rubble, a constant).

a = outside slope face angle with horizontal, DEGREES.

$$\text{Equation 3. } W = \frac{0.00231 \text{ H}^3 \text{ SGR}}{[(\text{SGR} / \text{SGW}) - 1]^3 \text{ SIN}^3 (r - a)}$$

W = theoretical **minimum rock mass (size or weight)** which resists deep water wave forces and remains in the revetment, TONS.

H = significant wave height, FEET (average of the highest 1/3 of the waves).

SGR, SGW, r, and a are the same as in Equation 2 above.

See 5-2-B for height limits above still water to protect the bank from wave run-up.

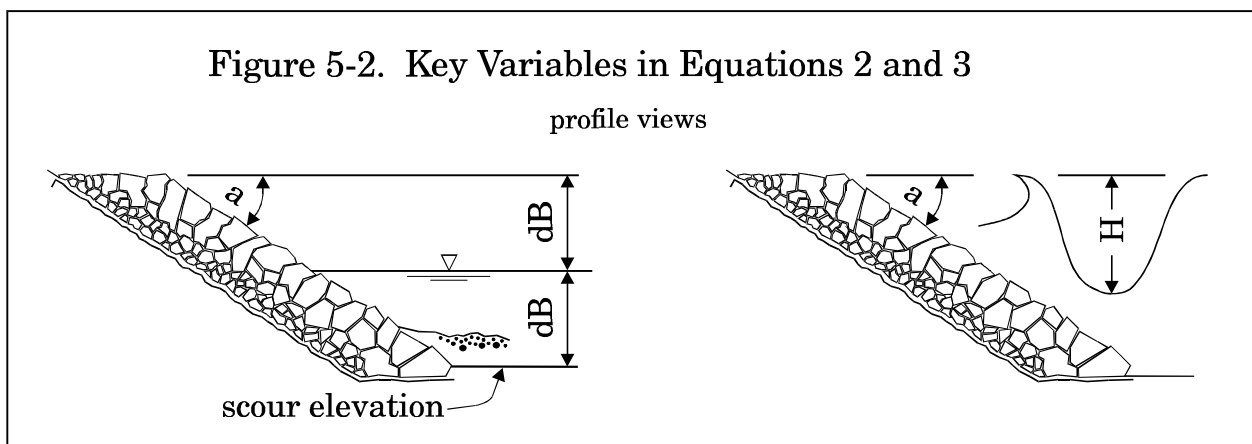

5-2-B. Design Advice. Seek help from experienced designers in the Corps of Engineers and/or Caltrans. Ocean shore RSP is similar to riverbank RSP. Follow steps of sections 5-1-A through F, except in step 5-1-C calculate minimum rock weight by Equation 2 or 3. Use Tables 5-1 and 5-2. If needed, minimum layer thicknesses in Table 5-3 may be increased. Height of riprap above maximum still water should be the lower value of $(2dB)$ or $(dB+H)$, so wave run-up will not go over the top of the revetment. Additional design information is in Reference 46 (Caltrans, *Highway Design Manual*) Section 873.3 "Rock Slope Shore Protection", while a comprehensive presentation of wave height, rock sizing, and shoreline protection facilities is in Reference 45 (CERC). References 45 and 46 also have some data design charts.

5-2-C. Other Data Sources. To determine scour depths for calculating dB in Equation 2, consult with experienced designers and interview local people who may have information of past conditions. Along the California coast, obtain scour observations from October through April, before and after severe storms. Gaged sites with historical tidal extremes are available, and if near your project, the data may be useful in Equation 2. With a personal computer you can access real-time and historical data on the Internet. Here's a few world wide web sites with links that were valid in October 2000. For near real-time tide levels and predictions, go to National Oceanographic and Atmospheric Administration's (NOAA) "Tides Online" home page <http://www.co-ops.nos.noaa.gov/tidesonline/> and under **Select Stations By**, click on **State Maps**, then click on the map of CA to get to the real-time stations. From the tidesonline home page, for historical data, under **Other Options** click on **Historical Data Retrieval** and you should get to http://www.co-ops.nos.noaa.gov/data_res.html where there are links under **Verified / Historical Water Level Data**.

The following sources may have wave data for determining H in Equation 3.

- a. For wave heights at stations close to shore, go to <http://cdip.ucsd.edu> the Coastal Data Information Program (CDIP), click on **DATA** and as instructed, click on a station name to get historical data, then click on **Product Availability**.
- b. For wave heights farther from shore, go to <http://www.ndbc.noaa.gov/stations.shtml> the National Data Buoy Center (NDBC) of NOAA. Click on **NDBC Online Data Archive** and then find the link to **Historical data**.
- c. For wave heights along the northwesterly CA coast, call Professor Jeffrey C. Borgeld at: Department of Oceanography, Humboldt State University, Arcata CA 95521, phone 707-826-3328 or Telonicher Marine Lab (Trinidad CA) phone 707-826-3687 or send an email to jcb2@humboldt.edu

6. Investigative Process

The tentative list of RSP design methods to investigate came from Reference 12 (Brown & Clyde, "new" HEC-11). It showed seven methods for sizing RSP:

1. CABS Reference 1
2. USBR EM 25 Reference 2
3. HEC-11 References 3, 12
4. CORPS Reference 4
5. HEC-15 Reference 8
6. ASCE Manual 54 Reference 9
7. Simons and Senturk Reference 10

Comparing this initial list to Table 2-1, various agencies use items 1, 3, and 4 more or less directly, while items 5, 6, and 7 were adopted with variations. Item 2 is not a bank and shore method per se, it is specific for stilling basins and culvert outlets.

Research is guided by an experimental design or investigative process. Typically, for materials or product comparisons, data are collected on several variables. The data are then plotted and used in a numerical procedure, like analysis of variance (ANOVA). Such analyses appeal to the engineering community, because they seem objective as opposed to subjective. As contrasted with typical product comparisons, the process for investigating RSP design methods was subjective. In our investigative process we:

- a. learned the RSP design methods via literature,
- b. developed a list of conditions which cause failure of RSP revetments,
- c. interviewed local engineers, design practitioners, and some method authors,
- d. field-reviewed existing RSP sites with local engineers in five states,
- e. recorded site data and rated sites (as successful, or failed and repaired),
- f. rated the RSP design method based on the site rating,
- g. selected effective RSP design methods.

The investigative process we followed is as valid as ANOVA or other "objective" numerical procedures. Sites were not rated exclusively by us (authors of this report). We relied on judgments of individual field-reviewers, most of whom were experienced and licensed civil engineers in their respective states. As the overall raters of the RSP design methods, we assessed the field reviewers and asked about their experience. In the field they demonstrated their knowledge of specific sites, design and construction methods, and prior conditions. Thus, our credibility and decision-making process is based on a consensus of engineers, practitioners, and method authors.

A major task was locating RSP sites for each design method. After interviewing and corresponding with engineering staff in Caltrans and the Corps of Engineers, we found out that not all the design methods were common in California practice, and therefore for several methods there were no RSP sites in CA. We reviewed literature which is

presented in Chapter 8, "Annotated References" and found out that there were no sites with "side-by-side" revetments on the same river or stream, that is, one revetment built by each of the design methods. We found no sites for HEC-15 or USBR-EM-25. However, in Reference 14 (Blodgett & McConaughy) there was a table of evaluated sites. We contracted with Mr. Blodgett to expand his Table 7 on pages 55 and 56 with data like: RSP design methods and locations. Blodgett was planning yet another RSP design method, which was never published, and by which no sites were ever built. After screening his data, we selected one of his sites in Oregon. Additional sites were needed for field review, and it was required to go to states other than CA.

We corresponded with method authors and engineers in other state departments of transportation, besides California. We requested sites to field-review, defined *successful* and *failed* RSP, and revetment failure mechanisms. Exhibit 6-A is an edited version of our multi state inquiry for RSP-site information. It was faxed or mailed to design, maintenance, and construction engineers and method authors. A nearly complete list of people who were contacted is listed in Chapter 9, "Personal Communications," and those who are listed in bold print did the RSP site reviews and evaluations with us. Dr. Stephen T. Maynard, principal author of the CORPS method of Reference 4, arranged a tour of RSP sites in Washington with Jim Lencioni, Les Soule, and Dick Burnham (retired) of the Seattle Corps District. Dr. Maynard also organized a tour in Mississippi with Charles Little of the Vicksburg District. Dave Bryson and Chris Dunn selected sites in Oregon, while Gary Johnson, Rick Moser, Ben Urbonas, and Frank Rosso selected sites in Colorado. Dennis McBride, Charlie Fielder, and John Bulinski were just a few Caltrans engineers who located RSP sites in California. Regarding personal communication with other design method authors, they either did not respond, were not located, or were deceased.

As we discovered during our investigation, stone size and velocity are a few factors which determine the success or failure of RSP. The "data guide" of Table 6-1 was used for RSP site evaluations. Several factors at most sites were not easily quantified and sometimes not even known, like: the duration and frequency of prior flooding, the number of overtopping events, actual velocities or wave heights, changed angles of attack over the service-life of the revetment, debris or other temporary obstructions, and altered streambeds. There were a lot of gaps in the data for many sites. However, there was enough field evidence and non documented personal experience of field reviewers to rate each site and the RSP design methods.

Exhibit 6-A. Inquiry for RSP site Information

We would like to field-review successful and failed sites. Failed sites do not have to be dramatic or spectacular kinds of failures, just a performance less than expected from the original design. If possible, we would like to visit 3 successful and 3 failed sites. If compiling site dossiers proves to be cumbersome, then please scale-down our request to a "minimum" visit: 1 successful and 1 failed site. Besides locating such sites, we need information which is listed on the next sheet. (Table 6-1 in this report).

Successful sites have had little or no maintenance, especially after being exposed to design floods or high-velocity flows. It is possible for successful sites to have withstood damage, when flows, depths, and velocities were greater than design values.

Failed RSP sites usually require frequent repairs after moderate to severe events. We have found that most people do not readily admit to failures. With a site dossier and by visiting the site, we might be able to determine why the riprap design method failed. If failed sites have been remedied, then knowing conditions "before repairs" would be very useful for an evaluation. "Before" photographs would be very useful.

If no sites have failed, then possibly, such sites were either "overdesigned" or "overbuilt" or both. Two general mechanisms of RSP failure are:

1. particle erosion (revetment rocks and/or underlying slope soil removed by water).
2. underlying slope material fails (poor material, saturation, slope angle too steep, slippage plane, base rotation).

There are also stages or combinations of these failure mechanisms.

Specific causes of RSP failure include:

1. channel is constricted (via debris, narrow gorge or bridge upstream, recent channel "repairs" by just adding extra thickness of rock to a previously failed section), causing local velocities to be greater than design velocity:
 - A. higher magnitude velocity with impinging vectors (& turbulence) displaces and removes rocks or soil. With sustained impingement, rocks and/or soil are removed either gradually (several storms) or suddenly (same event).
 - B. higher magnitude velocity with parallel vectors (& laminar or transitional flows) causes "suction force" that removes "lighter" or smaller particles:
 - i. which are loosely stacked on outer surface.
 - ii. which are not held firmly by outer matrix.
 - iii. which "worm out" from below surface layer of rock through voids in outer matrix, due to lack of a filter/separator.
2. toe undermined (mining, steep gradient, incised bed, headcutting, transverse or skewed inflows)
3. rocks are too small to withstand design or smaller flows (or velocities).
4. rock revetment not thick enough.
5. rounded rocks roll out of matrix (or make a viscous layer)
6. slope too steep.
7. poor quality of rock.

Table 6-1. Data Guide and Questions for Field Evaluations

1	state in US
2	name of river or creek
3	district, for example Caltrans District 1-12
4	county
5	state route number or road designation, for example I-5
6	mileage along route (post mile)
7	number of nearby bridge
8	RSP design method & year of publication
9	agency responsible for building & maintenance
10	date of field visit
11	type of RSP revetment, flexible riprap or concreted rock
12	date when RSP was built
13	agency contract number
14	did RSP ever fail ? yes or no
15	was RSP ever repaired ? yes or no
16	location map on file ? yes or no
17	as-built plan & profile ? yes or no
18	designer's name
19	designer's phone number
20	class of riprap on outer layer, like "Heavy", "1 ton", "Class V"
21	number of known overtoppings of RSP revetment
22	estimated flow rate during overtopping event
23	depth to channel bottom from top of RSP. If thalweg depth, code T & depth
24	average stream velocity at overtopping
25	impinging flow N=no, F=at full depth or overtopped, L=low flow
26	any photographs ? yes or no
27	remarks ephemeral flow, controlled by dam release, in-stream mining, rocks moved by fisherman, maintenance history, vegetation regenerated naturally, planted vegetation, etc.
28	responsible agency's evaluation, overall impression
29	was RSP facility inexpensive or costly ?
30	stone quality estimate by hammer test: excellent good poor
31	failure mode, T=toe scour, BU=backslope unstable, SS=steep slope
32	stone parentage (igneous, metamorphic, etc.) or name of quarry
33	shape of rocks A=angular, S=subangular, R=rounded
34	is stone size within specifications ? yes or no
35	is there a filter layer or any backslope protection ?
36	geotextile or RSP-fabric present? woven filament or nonwoven ?
37	any contract specifications for rock ?
38	any contract specifications for geotextile ?
39	field description of backslope soils and slope angles

Chapter 7. Field Evaluations

Summary information in Table 7-1 is based on data of Table 7-2. The last three design methods in Table 7-1 are not included in any of the preceding Chapters, because there were no background references or engineers to contact at the respective sites. This may be a task for future researchers. We did not conclude whether a method is effective or not based on Table 7-1. Tallies are intended only for future investigators, who might want to locate and evaluate additional sites to undergo a critical field-evaluation procedure similar to what we did that includes at least three field evaluators. See Chapter 6 for details.

Table 7-1. Site Tallies by RSP Design Method

Abbreviation and Name of Method	Number of Sites	Failed or Repaired
CABS / California Bank and Shore river or streambank	7	3
CABS / California Bank and Shore ocean	2	0
HEC-11 / Hydraulic Engineering Circular No. 11	1	0
CORPS / US Army Corps of Engineers	28	11
CERC / Coastal Engineering Research Center Army Shore Protection Manual	3	0
CODOT / Colorado Department of Transportation	9	3
OR Keyed / Oregon Keyed Riprap	3	0
DUDFCD / Denver Urban Drainage Flood Control District	5	2
SCS / Soil Conservation Service	3	0
ASCE / American Society of Civil Engineers Manual 54	2	2
unknown	2	0

Table 7-2 is a synthesis of data which were recorded on site inventory forms shown in Table 6-1. A geographic sort was presented in the event there are future site re-evaluations. We welcome additional information about the RSP-sites reported in Table 7-2 or any other RSP sites. Contact the principal author, see Chapter 4 for phone number, e-mail, and address. Some common symbols and abbreviations used in Table 7-2 are:

d/s	downstream
u/s	upstream
"	inch
#	pounds
>	is greater than
>>	is significantly greater than, perhaps doubled or more
<	is less than
W50	weight of the median-sized stone
D50	effective diameter of median stone (does not mean it is a sphere)
1V:2H	tangent of slope angle in profile view, vertical to horizontal ratio
'	feet
6'V:20'H	actual measurements of tangent of slope angle vertical and horizontal values given in feet (')
var'H	variable horizontal distance in feet
-	not minus, but "to". For example "500#-25#" stands for the range is 500 pounds to 25 pounds
OK	successful, satisfactory, functioning well
@	at
Q5	flow rate of the 5-year return period
cfs	cubic feet per second
%	percent
VL	very light designation of a riprap gradation
L	light ditto
M	medium ditto
H	heavy ditto
VH	very heavy ditto

"CORPS Seattle EM-1110 1970" stands for the CORPS RSP design method by the Seattle District based on EM "Engineering Manual 1110" published in 1970. Other design method abbreviations are shown in Tables 7-1; they are similar to Table 1-1.

TABLE 7-2. FIELD EVALUATIONS			
site number location	method source edition	description	when built status evaluated
1 Nisqually River Thurston County Washington	CORPS Seattle EM-1110 1970	river bank. 48" thick Class V 1800#-25# W50 750# rock filter layer	1977 OK 12 May 1992
2 Skookumchuck River Lewis County Washington	CORPS Seattle EM-1110 1970	river levee. failure: debris impinged repair: 24" thick Class II 500#-25# W50 200# gravel layer, toe >500#	1971 repaired 1989 OK 12 May 1992
3 Puyallup River Pierce County Washington	CORPS Seattle EM-1110 pre-1948	tidal river levee. failure: toe scour 1000' repaired with 24" rock. 4 miles levee OK	1948 repaired 1970 OK 12 May 1992
4 Cedar River Orchard Grove King County Washington	CORPS Seattle EM-1110 1970	river levee. failure: toe scour repair: 30" thick Class III 800#-25# W50 300# extended toe from 3'Vx4'H to 8'H	1975 repaired 1977 & 1990 OK 13 May 1992
5 Cedar River Dorre Don King County Washington	CORPS Seattle EM-1110 1970	river levee. failure: toe scour repair: 30" thick Class III 800#-25# W50 300# extended toe from 3'Vx4'H to 8'H	1975 repaired 1977 & 1990 OK 13 May 1992
6 Cedar River Rainbow Bend King County Washington	CORPS Seattle EM-1110 1970	river levee. failure: toe scour repair: 30" thick Class III 800#-25# W50 300# extended toe from 3'Vx4'H to 8'H	1975 repaired 1977 & 1990 OK 13 May 1992

TABLE 7-2. FIELD EVALUATIONS			
site number location	method source edition	description	when built status evaluated
7-A Green River King County Washington	CORPS Seattle EM-1110 1970	river bank. 24" thick Class II rock toe & trees planted on slopes	1981 OK 13 May 1992
7-B Green River by golf course King County Washington	CORPS Seattle EM-1110 1970	river bank. rock toe & plastic geogrid-gabions on slopes 1V:0.5H & 1V:1H	1990 OK 13 May 1992
8-A South Fork Skagit R. areas A & B Skagit County Washington	CORPS Seattle EM-1110 1970	tidal river levee. failure: inadequate filter, saturated bank, stage dropped fast, material piped out. repair: 48" thick Class II, 12" gravel bedding above water, rock spalls below, 6'Vx20'H weighted toe, Class IV 1000#-25# W50 400#	pre-1980 repaired 1991 OK 14 May 1992
8-B North Fork Skagit R. area C Skagit County Washington	CORPS Seattle EM-1110 1970	tidal river levee. failure: bed & toe scour repair: 60" thick Class V, 1800#-25# W50 750# 12" gravel bedding above water, rock spalls below, 10'Vx16'H weighted toe Class IV KEYED into Class V above water line	pre-1980 repaired 1991 OK 14 May 1992
8-C North Fork Skagit R. areas D & E Skagit County Washington	CORPS Seattle EM-1110 1970	tidal river levee. failure: toe scour repair: 24" thick Class II, 12" gravel bedding above water, rock spalls below, 3'Vx10'H weighted toe	pre-1980 repaired 1991 OK 14 May 1992

TABLE 7-2. FIELD EVALUATIONS			
site number location	method source edition	description	when built status evaluated
9 Skykomish River Hansen Dike Snohomish County Washington	CORPS Seattle EM-1110 1970	river levee. 60" thick Class V KEYED riprap (smooth surface by slapping with 2 cubic yard bucket or dropping 5000# steel plate from 4'). groins @ toe create eddies & slow current for fish habitat	1991 OK 14 May 1992
10 South Umpqua River Myrtle Grove Slide Old Dillard Highway Douglas County Oregon	FHWA HEC-11 1967 modified	river bank. 48"-60" thick Class 2000 2000#-40# W50 700# 1' Class 50 filter blanket & buttress fill Class 50 50#-2# W50 15# 5'Vx var'H weighted toe	1989 OK 18 May 1992
11 Nesika Beach US 101 mile 320 Curry County Oregon	CERC Shore Protection Manual 1977	ocean shore. 1984 surf zone: 9.5' design wave 1V:3H slope 8' thick primary cover stone 6300#-4000#, 5' thick secondary cover stone 660#-350#, 1' Class 50 & geotextile backshore: 4' Class 2000 1' Class 50 & geotextile surf zone protection extended in 1987: 1V:2H slope 7' primary cover stone 5700#-3400#, 3.5' secondary cover stone 600#-320#, 1' Class 50 & geotextile	1984 & 1987 OK 19 May 1992

TABLE 7-2. FIELD EVALUATIONS

site number location	method source edition	description	when built status evaluated
<p>12 Pistol River & Beach US 101 mile 339 Curry County Oregon</p>	<p>CERC Shore Protection Manual 1977</p>	<p>river bank & ocean shore. north bridge abutment: 4' thick Class 2000 1' Class 50 & geotextile. south bridge abutment same, but no geotextile</p>	<p>1984 OK 19 May 1992</p>
<p>13 Myers Creek & Beach US 101 mile 337 Curry County Oregon</p>	<p>CERC Shore Protection Manual 1977</p>	<p>river bank & ocean shore. north bridge abutment: 4' thick Class 2000 1' Class 50 & geotextile</p> <p>Note: Class 2000 is a well-graded mixture with light rock, 2000#-40# W50 700#. Photos C-23 & C-24 in Appendix C show light rocks were displaced from revetment into Creek</p> <p>south bridge abutment: gradation of outside layer (primary cover stone) eliminated lighter rock: 5.5' thick primary cover stone 2070#-1240# with 75 percent 1650#-2070#, 3' thick middle layer well-graded 215#-115#, & 1' Class 50 filter layer</p> <p>Note: Photo C-26 in Appendix C shows south bridge abutment primary stone > 2070#</p> <p>surf zone: 5' Class 5000 5000#-<150# W50 1700# & 1' Class 50</p>	<p>1984 OK 19 May 1992</p>

TABLE 7-2. FIELD EVALUATIONS

site number location	method source edition	description	when built status evaluated
<p>14 Salmon Creek Willamette Highway Rte. 58 east mile 35 Lane County Oregon</p>	<p>CORPS Portland EM-1110 pre 1957</p>	<p>river levee. Failures from impinging flow apparently caused by debris & shifting gravel bars, which undermined toe at banks built to parallel flow criteria: rounded rock, 1V:2H slope, no filter layer, 24" thick Class III 800#-25# W50 300#. Channel capacity increased 6' due to degradation since 1959. Portions of levee repaired with OR DOT Class 2000 KEYED riprap. Bridge abutments protected with concrete- filled fabric.</p> <p>Note: Criteria at that time for impinging flow was 30" thick Class IV 1600#-50# W50 600#, for parallel flow it was 24" thick Class III.</p>	<p>1959 failures in 1964, 1971, & 1986 repaired OK 20 May 1992</p>
<p>15 South Santiam River I-5 Safety Rest Stop Marion County Oregon</p>	<p>OR DOT KEYED RIPRAP 1974</p>	<p>river bank. KEYED Class III 800#-25# W50 300# 1' Class 50 filter layer. less turbulence from KEYED riprap & most rocks do not wobble when walked on.</p> <p>Note: This was the first KEYED riprap in OR.</p>	<p>1965 OK 20 May 1992</p>

TABLE 7-2. FIELD EVALUATIONS			
site number location	method source edition	description	when built status evaluated
16 Willamette River Minto Brown Island Marion County Oregon	CORPS Portland unknown	river bank. OR DOT KEYED riprap Class 700 700#-20# W50 200# island submerged by floods about every 2 years	1986 or 87 OK 20 May 1992
17 South Santiam River Rte. 226 mile 1.45 Linn County Oregon	ORDOT KEYED RIPRAP 1974	river levee 1st KEYED riprap in OR. Using KEYED Class III instead of Class 2000 reduced thickness by 1'. 1' Class 50 filter	1974 OK 20 May 1992
18 Big Thompson River Rte. 34 mile 76.3 near Indian Trading post & Estes Park Larimer County Colorado	CODOT design manual early 1970's	river bank. LIGHT 160#-1.3# W50 35# no filter, gravelly bank. @ bare soil zones rocks likely moved by fisherman	1978 OK 15 Jun 1992
19 Big Thompson River Rte. 34 USGS gage B6 Larimer County Colorado	CODOT design manual early 1970's	river bank. slope: MEDIUM 440#-3# W50 85# toe: VERY HEAVY 3500#-35# W50 650#	1978 OK 15 Jun 1992
20 South Platte River 88th Av drop structure Adams County Colorado	Denver UDFCD Vol 2 of Drainage Manual 1984	river bank. drop structure, concreted rock Type H 1280#-10# W50 275# failure: scoured Type VL riprap 85#-0.4# W50 10# just D/S of drop fixed with Type L riprap 160#-1.3# W50 35# & sandbar willow (bends easily), no filter because backslope is gravelly sand	mid-1980's repaired OK 16 Jun 1992

TABLE 7-2. FIELD EVALUATIONS			
site number location	method source edition	description	when built status evaluated
21 South Platte River u/s of I-76 & D/S of drop structure Adams County Colorado	Denver UDFCD Vol 2 of Drainage Manual 1984	river bank. parallel flow, Type L riprap to Q5 stage 160#-1.3# W50 35# (diameter ranges, inches with specific gravity=2.5) 15 to 3 D50 9 1V:2H slopes	mid-1980's OK 16 Jun 1992
22 South Platte River u/s of I-76 & U/S of drop structure Adams County Colorado	Denver UDFCD Vol 2 of Drainage Manual 1984	river bank. impinging flow, Type M riprap to Q5 stage 440#-3# W50 85# above Q5 soil cover with grass & willows planted over "traditional" riprap for habitat & aesthetics 1V:2H slopes	mid-1980's OK 16 Jun 1992
23 Sanderson Gulch tributary of S. Platte Denver County Colorado	Denver UDFCD Vol 2 of Drainage Manual pre-1975	stream bank. failure: Type L toe scoured, rock too small, no filter layer repair: concreted existing Type L riprap	1970 failed 1975 OK 16 Jun 1992
24 West Harvard Gulch tributary of S. Platte Denver County Colorado	Denver UDFCD Vol 2 of Drainage Manual 1984	stream bank. geotextile & interlocking concrete blocks (TRI-LOCK), hydroseeded	1987 OK 16 Jun 1992
25 Goldsmith Gulch Denver County Colorado	Denver UDFCD Vol 2 of Drainage Manual 1984	stream bank. incised 12'Vx20'H check dams failed repair: Type M & buffalo, wheat, & canary grasses. local erosion zone fixed with GEOWEB	1990 OK 16 Jun 1992

TABLE 7-2. FIELD EVALUATIONS			
site number location	method source edition	description	when built status evaluated
26 Eagle River east of Gypsum I-70 mile 141 Eagle County Colorado	CODOT design manual early 1980's	river bank. natural bank failed from impinging flow, undercut. repaired: 4' thick HEAVY riprap (same as Denver UDFCD Type H) 1280#- 10# W50 275#. Toe 4'Vx7.2'H, no filter layer, round rock, steep slope 1V:1.5H	unknown repair 1985 OK 17 Jun 1992
27 Colorado River I-70 mile 122+ next to bikeway from Grizzly to Shoshone Garfield County Colorado	CODOT design manual 1987	river bank. bikeway @ Q5 stage. Designed 4' thick HEAVY riprap, but as-built has zones of larger rock, no filter layer. When no HEAVY riprap, toe was KEYED. Several >2 ton rocks placed @ toe for fish habitat. Voids soil-filled, covered & planted, a few holes where soil piped through. Better success when willows & other species planted in early spring, just before end of dormancy, below Q5 stage	1988 & ongoing OK 17 Jun 1992 (latest inspection JAN 1996 OK)
28 Colorado River I-70 mile 119 east of No Name interchange Garfield County Colorado	CODOT design manual early 1980's	river bank. before: >22,000 cfs impinged on rounded MEDIUM riprap + timber cribs & willows, only one crib beyond impinging zone withstood flood. repaired: HEAVY riprap local subangular-rounded, >3' diameter rock toe , no filter, gravelly sand bank	riprap & timber cribs pre-1984 repaired 1985 OK 17 Jun 1992

TABLE 7-2. FIELD EVALUATIONS			
site number location	method source edition	description	when built status evaluated
29 u/s of archaeological site I-70 mile 107.5 Garfield County Colorado	CODOT design manual late 1960's	river bank. far bank: failed, no filter, not repaired (range land). near bank: >>8 ton-75# poor gradation. several surface void zones where small rock removed during flood stages. no filter layer, sand fill	1972 far bank failed, near bank OK 18 Jun 1992
30 d/s of archaeological site I-70 mile 108 Garfield County Colorado	CODOT design manual late 1960's	river bank. wall built on opposite bank protects arch-site, causes impinging flow. near bank: >>8 ton-5# poor gradation. zones repaired by maintenance with 200#- 500# rock toe & steep slopes with W50<50#. more repairs expected from loss of small loose surface rock. no filter, sand fill	1972 failed and repaired various OK 18 Jun 1992
31-A I-70 mile 96 bridge F-6-Y @ Silt Garfield County Colorado	CODOT design manual early 1970's	river bank. & bridge abutments 30" thick HEAVY riprap, 4'Vx4'H rock toe, no filter. small rock washed out where surface has voids	1975 OK 18 Jun 1992
31-B I-70 exit 167, Avon Eagle River bridge named "Bob" Eagle County Colorado	unknown consultant design	river bank. bridge abutments: round riprap, comparable CODOT size MEDIUM high-cost contract slopes: 1V:2H & opposite bank 1V:1.5H	unknown OK 18 Jun 1992

TABLE 7-2. FIELD EVALUATIONS			
site number location	method source edition	description	when built status evaluated
31-C I-70 exit 198 Tenmile Creek near Officer's Gulch Summit County Colorado	CODOT design manual early 1970's	stream bank. native stream rock placed on banks, log checks & stump groins for fish habitat, various plantings restored riparian habitat	1975 OK 18 Jun 1992
32 Harlan Creek west of Lexington Holmes County Mississippi	CORPS Vicksburg	stream bank. R200 W50 50# longitudinal stone toe, control meanders	1987 OK 19 May 1993
33 Black Creek west of Lexington Holmes County Mississippi	CORPS Vicksburg	stream bank. R200 longitudinal toe, 4' high groins tied to bank (tiebacks) trap sediment & naturally revegetate	1990 OK 19 May 1993
34 Batupan Bogue Grenada County Mississippi	CORPS Vicksburg	stream bank. longitudinal toe eroded bank repair: reconstruct tiebacks higher to new bank, & redirect flow	1977 repaired 1978 OK 19 May 1993
35 Batupan Bogue Grenada County Mississippi	CORPS Vicksburg	stream bank. rock toe & tire mattress revetment, revegetated	unknown OK 19 May 1993
36 Batupan Bogue by subdivision Grenada County Mississippi	CORPS Vicksburg	stream bank. 1V:1H riprap bank, oversteepened by launched rock, naturally revegetated	unknown OK 19 May 1993

TABLE 7-2. FIELD EVALUATIONS			
site number location	method source edition	description	when built status evaluated
37 Batupan Bogue Grenada County Mississippi	CORPS Vicksburg	stream bank. natural stream (no dams u/s), before erosion R200, repair: R400 hard-point dikes (same as tiebacks)	damaged 1989 repaired 1991 OK 19 May 1993
38 Worsham Creek Mississippi	CORPS Vicksburg	stream bank. incised channel bottom, acoustic sounder scour gage from bridge. repair: modified Oxford Agricultural Research Service's grade control structure. u/s weir & R1000 + baffle dissipates jet & wave, same structures d/s except R400 moved >10' from weir. With u/s & d/s controls, incision & bank collapse arrested	1987 OK 19 May 1993
39 Burney Branch through Oxford Lafayette County Mississippi	SCS design (soil con- servation service) unknown	stream bank. built by Corps, bottom & sides riprapped	unknown OK 20 May 1993
40 Hotopha Creek Mississippi	CORPS Vicksburg unknown	stream bank & bottom. nearly vertical banks, successive grade control structures reduce head cuts & bank failures in silty material. weir drops stream into double box culvert with concrete invert. next d/s control drowns out 5' head cut	unknown OK 20 May 1993

TABLE 7-2. FIELD EVALUATIONS			
site number location	method source edition	description	when built status evaluated
41 Hotopha Creek d/s of site 40 Mississippi	CORPS Vicksburg unknown	stream bank & bottom. 15' drop, concrete weir & sidewalls, riprap banks & bottom, 5' thick 1/4 ton with fabric	spring 1993 OK 20 May 1993
42 Hotopha Creek USGS stream gage Mississippi	CORPS Vicksburg unknown	stream bank. rock hardpoint transverse dikes, trap sediment & revegetate naturally. longitudinal rock toe trains low Q under bridge. planted willows in rock toe creates localized shade for fish habitat	unknown OK 20 May 1993
43 Johnson Creek Mississippi	SCS unknown	stream bank. fabric & Gobi blocks (interlocking, preformed concrete). missing blocks on steepened banks @ zones of undermined toe	unknown OK 20 May 1993
44 Johnson Creek Mississippi	CORPS Vicksburg unknown	stream bank. incised bed. rock placed in windrow along lower bank above low stage. rock launches when undercut, protects toe & banks from steepening	unknown OK 20 May 1993
45 Long Creek Mississippi	CORPS Vicksburg unknown	stream bank. constricted grade control (instrumented) & baffle creates backwater, which dampens flow in u/s reach of rock revetted meanders, sandy banks & bottom	unknown OK 20 May 1993

TABLE 7-2. FIELD EVALUATIONS			
site number location	method source edition	description	when built status evaluated
46 North Fork Tillatoba Creek section 32 site 3A Mississippi	CORPS Vicksburg unknown	stream bank. riprapped banks, naturally revegetated	pre-1978 OK 20 May 1993
47 North Fork Tillatoba Creek Mississippi	CORPS Vicksburg modified ARS design	stream bank. grade controlled by weir (steel piles) & high Q jet & velocity dampened by baffle (concrete-filled steel piles). riprapped banks & below weir drop. fish seen under log debris pile @ baffle	pre-1978 OK 20 May 1993
48 North Fork Tillatoba & Hunter Creek Site Nos. 1 & 2 Mississippi	SCS & Talla- hatchie County Soil & Water Cons. District	stream bank & bottom. riprapped banks & bottom to control bed incision & prevent bank failure	about 1990 OK 20 May 1993
49 South Fork Tillatoba Creek, near Charleston Tallahatchie County Mississippi	CORPS Vicksburg unknown	stream bank. u/s of bridge: tire revetment with natural revegetation. d/s of bridge: tire-filled, wire crib retard	unknown OK 20 May 1993
50 Dry Creek Rte. 132 mile 16 Stanislaus County California	CA Bank & Shore 1970	river bank. geotextile & LIGHT Class 500#-25# W50 200# also protects bridge abutment. brush d/s of riprap bent down by high velocities	1988 OK 8 April 1992

TABLE 7-2. FIELD EVALUATIONS			
site number location	method source edition	description	when built status evaluated
51 un-named creek Rte. 4 mile 29.64 Calaveras County California	CA Bank & Shore 1960	stream bank. 4' thick 1/2 ton Class 1 ton-200# W50 1/2 ton for parallel & impinging flow. 75# stable rock in channel suggests overbuilt. trees rooted in voids. maintenance history: Brush removed in channel near entrance & exit of double 4'Hx8'W culvert prevents flooding.	pre-1964 OK 8 April 1992
52 Rock Creek Rte. 4 mile 1.68 Stanislaus County California	CA Bank & Shore 1970	stream bank. 2.5' thick LIGHT Class 1/4 ton-25# W50 200# protects bridge approach fills, abutments, & channel bottom	1977 OK 8 April 1992
53 South Fork Eel River US 101 mile 21.7-22 Humboldt County California	state of practice, likely ASCE manual 54. precursors of HEC-11 & CA Bank & Shore, mid-1950's	river bank. failure, 1964 floods: no filter, thin lower & upper zones, fill piped out as stage dropped. lower 15' was 2' thick Method B 1/2 ton Class & upper zone 1/4 ton Class. repair: planned 1/2 ton Method B 3.5' thick & raised elevation. As-built 4 ton-25# rock. Chink-rock <50# (CA 1954 spec) in upper zone not found in lower zone, where chink rock removed by floods. Silt deposited in voids of lower zone large rocks, where volunteer trees & brush grow	1962 failed 1964 repaired 1965 OK 3 Feb 1993 & Feb 1996

TABLE 7-2. FIELD EVALUATIONS			
site number location	method source edition	description	when built status evaluated
54 South Fork Eel River US 101 mile 25.4-26.3 Humboldt County California	likely ASCE manual 54. precursors of HEC-11 & CA Bank & Shore, mid-1950's	river bank. impinging zones: 4' thick Method B 1/2 ton Class toe & upper zone 3' thick 1/4 ton Class, unknown gradations, filter layer. parallel zones: thickness reduced by 1' & no filter. repairs: elevation raised, southerly end extended, impinging zones thicker sections & >> 1/2 ton rock	1961, repaired 1965, 1968, & 1969 OK Feb 1993
55 South Fork Eel River US 101 mile 25.3 near Salmon Creek Humboldt County California	CA Bank & Shore 1970	river bank. repair road fill: no prior riprap, impinging zone Method B 1/2 ton Class, No. 1 Backing Class 200#-25# W50 75#, & RSP-fabric at 1V:1.5H, extra rock along toe for fish habitat. Soil cap at 1V:2H seeded, excelsior blanket in green ultra-violet degradable plastic net. no planted trees survived. fish habitat buried in silt	1994 OK Feb 1996
56 Van Duzen River by Grizzly Creek State Park campground Rte. 36 mile 16.9 California	CA Bank & Shore 1960	river bank. failure: 3.5' thick 1/4 ton, flow impinges, undersized rock & no filter layer. repair: specified 1 ton Method B, but >4 ton rock placed along toe. D/S & U/S ends tied to natural rock outcrops. volunteer alders in RSP get washed away during high flows	1968 failed & repaired 1970 OK Feb 1993 & 1996

TABLE 7-2. FIELD EVALUATIONS

site number location	method source edition	description	when built status evaluated
<p>57 Rte. 128 mile 4.21 Novarro River Redwoods State Park Mendocino County California</p>	<p>CA Bank & Shore 1970</p>	<p>river bank. No prior riprap, road washed out & rebuilt with quarry pit run material. When 75% done, Q10 stage overtopped road & washed away 4" soil cover. Method B 1/2 ton RSP- Class, geotextile, no filter, 1V:1.5H steep slope, 10' deep toe, thinner on bedrock. Extra 2-4 ton rocks placed @ toe for roughness & habitat diversity. Voids filled with soil. Planted willow poles. 4-inch soil covers RSP, seed & mulch</p>	<p>March, 1995 overtopped during repair OK April, 1995 (evaluated by Carlos Portillo & Mark Moore of Caltrans District 1)</p>
<p>58 Pacific Ocean Rte. 1 mile 8 near Alder Creek Monterey County California</p>	<p>CA Bank & Shore 1970</p>	<p>ocean shore. revetment 9' thick: 8' thick 6 ton RSP-Class as-designed (8 ton RSP- Class measured in 1994) 1' thick PVC-zinc-coated rock-filled gabions, & geotextile. gabion layer reduced total thickness by 7' & eliminated inner layers of 1 ton & 1/4 ton RSP- Classes. 25' storm waves</p>	<p>1985 OK 1995</p>

TABLE 7-2. FIELD EVALUATIONS

site number location	method source edition	description	when built status evaluated
<p>59 Mad River Rte. 101 Vista Point miles R94.1-R94.6 Humboldt County California</p>	<p>CA Bank & Shore 1970</p>	<p>tidal river & ocean shore. Mad River mouth migrated northerly starting about 1971. In 1992 emergency contract to armor road fill & turn river westerly with RSP, prevented loss of Rte. 101. Special design: rock launches as toe & face erode. (ranges % larger than) 8 ton 0-5 % 4 ton 50-65 % 1 ton 75-90 % 1/4 ton 95-100 % 10-15' thick in launch zone & 10' on road fill. 1.5' thick Backing No. 2 RSP-Class. Heavy duty nonwoven needle-formed geotextile Z-folded for extra length as rock launches. Sand dune eroded south & u/s of 1992 armor. RSP extended 1000' u/s in 1995, but rock sizes scaled down: 4 ton 0-5 % 2 ton 50-65 % 1/4 ton 75-90 % 75 # 95-100 % Top area of launch zones capped with beach sand, revegetated naturally, some voids developed, but area is fenced.</p>	<p>1992 & extended RSP in 1995 OK MAY 1995 & FEB 1996</p>

TABLE 7-2. FIELD EVALUATIONS

site number location	method source edition	description	when built status evaluated
<p>60 Grizzly Creek Rte. 20 mile R41.5 Lake County California</p>	<p>CA Bank & Shore 1970</p>	<p>stream banks and bottom. 3'-4.5' thick Method B undersized 1/2 ton RSP- Class failed: steep channel grade, upper slope runoff & impinging transverse downdrains eroded behind fabric & above RSP. 1/2 ton rock gap-graded, poor interlock, no backing. 1V:2H channel side slopes, wrong RSP-fabric (low permittivity woven- tape, slit-film geotextile). Repaired: failed RSP used to fill scoured channel. 6' deep x 10' long concrete cutoffs at top, 3/5-down, & bottom of filled channel. pool/energy dissipater has concrete bottom & gabion weir outlet. RSP-fabric minimum permittivity 0.5/sec. channel grades vary 2.5% 21.7% 14%. 5' thick Method A 1 ton & 1' thick Backing No. 2. >1 ton allowed on channel invert, gap-graded. extra rock extends short distance beyond bottom cutoff. 1V:2H channel side slopes. concrete anchor & cable-stayed downdrains extend below RSP-fabric & tops of channel sides</p>	<p>1985 failed in March 1995, repaired in July, 1995 FEB 1996</p>

Chapter 8. Annotated References

- 1 California Division of Highways, *Bank and Shore Protection in California Highway Practice*, California Department of Public Works, November, 1970.
 - a excellent compilation of photographs & reports on bank protection initiated by "Joint Bank Protection Committee" in 1949
 - b recommends revising future design practice based on performance
 - c Chapter V is basis for rock slope protection design in CA, no examples
 - d no longer published or reprinted, 1st printing 1960 has errata sheet which corrects rock sizing equations, reprinted 1970 most of 1960 errata corrected
 - e commonly called "Bank & Shore Protection Manual", but never updated
 - f some text revised & put in Chapter 870 Caltrans Highway Design Manual

- 2 Peterka, A. J., *Hydraulic Design of Stilling Basins and Energy Dissipators*, US Department of Interior, Bureau of Reclamation, USBR-EM-25, 8th printing, May 1984 (1st printed 1958).
 - a Section 6 stilling basin impact dissipaters for culvert outlets to channels

- 3 Searcy, James K., *Use of Riprap for Bank Protection, Hydraulic Engineering Circular No. 11*, HEC-11, US Department of Transportation, Federal Highway Administration, Bureau of Public Roads, June, 1967.
 - a "old" HEC-11 uses channel velocity & recommends well-graded rock mixture
 - b page 11-31 of Appendix A erroneously cites California method doubles velocity for impinging flow, not true, it is $4/3$ mean channel velocity
 - c graphs of D50 stone size in Appendix A for several methods, US Bureau of Reclamation Method EM-25 applies to stones in stilling basins (not on banks)
 - d cites CA method uses "two layers" of overlapping stone.
notes by Racin: one-layer thickness= $1.5 \times D_{50}$ for large RSP-classes (3-point bearing, Method A) $1.875 \times D_{50}$ for riprap spread by machine (Method B, dumped).
"two layers" is inner layer of small sizes & outside layer of large sizes. wire enclosed riprap not used in CA anymore. call James A. Racin (see Chapter 4 herein) for Caltrans specs & standard construction details for GABIONS

- 4 US Army Corps of Engineers, "Engineering and Design, Hydraulic Design of Flood Control Channels", *Engineering Manual, EM 1110-2-1601*, Department of the Army, July 1970.
 - a References 43 & 44 (by Dr. Stephen T. Maynard) document basis for revisions to Corps method, most recent is "EM 1110-2-1601, Change 1, 30 June 1994"
 - b improved method for obtaining velocity increase factor in bends (impinging flow), depends on channel geometry & plan form of reach (range 1.1 to 1.45)
 - c *CHANLPRO* personal computer program to size riprap or gabions, estimate scour depth in bends. call Dr. Stephen T. Maynard 601-634-3284 or write:
USAEWES Hydraulics Lab WESHS-S
3909 Halls Ferry Road
Vicksburg MS 39180-6199

- 5 Anderson, Alvin G., Paintal, Amreek S., and Davenport, John T., *Tentative Design Procedure for Riprap-Lined Channels*, National Cooperative Highway Research Program NCHRP Program Report 108, Highway Research Board, National Academy of Sciences, 2101 Constitution Ave, Washington D.C., 1970.
 - a tractive force (shear stress) design procedure for $Q < 1000$ cfs
 - b experimental flume studies at University of Minnesota Saint Anthony Falls Hydraulic Lab, uniform (nearly same-size) riprap failed at 2x design Q, while graded riprap failed at 1.5x design Q
 - c graded riprap more effective than uniform riprap, prevents leaching (by leaching they mean scour of underlying bank material, that is, fines are sucked out through voids of riprap), but somewhat less stable than uniform material with regard to movement of individual particles"
 - d riprap layer 3xD50 thick prevented leaching (whether uniform or graded)
 - e research began 1966. key document used in HEC-15, Reference 8

- 6 Anderson, Alvin G., *Tentative Design Procedure for Riprap-Lined Channels - Field Evaluation*, Project Report No. 146, University of Minnesota St. Anthony Falls Hydraulic Lab, (prepared for Highway Research Board, NCHRP Program Project 15-2), Minneapolis, Minnesota, June, 1973.
 - a five channels built for small Q's <3900 cfs, OK after 4 years
 - b this field-study was follow-up of NCHRP 108, see Reference 5

- 7 Colorado Division of Highways, *Roadway Design Manual*, Denver, CO, 1987.
 - a Chapter 804 - Hydraulic Design presents variation of shear stress (tractive force) method, documented in References 5 & 6
 - b CO Department of Transportation published 1995 DRAFT Drainage Design Manual, styled after AASHTO Guide Drainage Manual, (American Association of State Highway Officials). In Chapter 17-Bank Protection, they refer to using "new HEC-11" for their riprap design procedure

- 8 Norman, Jerome M., *Design of Stable Channels With Flexible Linings, Hydraulic Engineering Circular No. 15*, HEC-15, Federal Highway Administration, Hydraulics Branch, October 1975.
 - a 1975 edition known as "old" HEC-15, 1988 edition is "new" HEC-15
 - b inquiries by Racin and Hoover revealed that neither "old" or "new" HEC-15 is used directly by DOT's or CORPS in WA, OR, CA, or MS. CO DOT uses a variation based on prior studies reported in NCHRP 108, References 5 & 6
 - c "old" based on d_{max} , maximum permissible depth, while "new" limits method to 50 cfs or less
 - d "old" uses maximum permissible depth of flow, while "new" uses maximum permissible tractive force
 - e "old" & new" have different criteria for filter fabric, however, granular blanket design is same
 - f "old" has procedure for short and long bends in channel

- 9 American Society of Civil Engineers, Sedimentation Committee of Hydraulics Division, edited by Vito A. Vanoni, *Sedimentation Engineering*, ASCE Manual No. 54, New York, 1977.
 - a first book edition 1975
 - b compiled from various technical reports from 1964-1975
 - c contributing authors of Chapter V, "Sediment Control Methods", J.W. Roehl et al in US Department of Agriculture, D.C. Bondurant, J.A. Hufferd, R.L. Vance, & J.J. Watkins
 - d page 534 Isbash (1936) formula for sizing rock by depositing in running water, basis for CA "Bank and Shore" formula for river and stream banks, flow velocity at 10 feet from bank, stream/bank angle 30 degrees or less

- 10 Simons, Daryl B. and Senturk, Fuat, *Sediment Transport Technology*, Water Resources Publications, Fort Collins, Colorado, 1992.
 - a tractive force design method, comprehensive text on sediment & riprap design, mathematical derivations, comparisons to other authors & methods (no field studies, "paper" studies)
 - b first edition 1977, example problems with 1992 edition *Solutions Manual*
 - c Dr. Simons reviewed & concurred with Mad River rock mixture designed jointly by Dennis McBride, Caltrans District 1 hydraulic engineer (1991), Tom Hoover & Jim Racin of Caltrans Sacramento Translab
 - d page 408 reviews CA Bank & Shore method and uses W , weight of critical stone, to calculate D_{50} , while Reference 1 states "2/3 of stone should be heavier", which means W should be W_{33} (no significant effect on analysis)

- 11 Chen, Y.H. and Cotton, G.K., *Design of Roadside Channels With Flexible Linings*, *Hydraulic Engineering Circular No. 15*, HEC-15, US Department of Transportation, Federal Highway Administration, Office of Implementation HRT-10, April, 1988.
 - a "new" HEC-15 riprap design for sides & bottom of roadside channels < 50 cfs, see notes for Reference 8, "old" HEC-15
 - b with Q,S,B, and Z, there's less guess-work in "new"
 - c "new" adaptable to trial & error solutions on programmable calculators, while "old" charts can be more time consuming

- 12 Brown, Scott A. and Clyde, Eric S., *Design of Riprap Revetment*, *Hydraulic Engineering Circular No. 11*, HEC-11, US Department of Transportation, Federal Highway Administration, Office of Implementation HRT-10, March, 1989.
 - a "new" HEC-11 riprap design for side slopes in large streams & flows >50 cfs
 - b method too new for sites to have been built and field-evaluated
 - c a shear stress method converted to a velocity-based procedure
 - d GABION specifications out-of-date & not accepted on Caltrans jobs. page 84 Table 5 criteria for gabion thickness ok, except Caltrans does not use 9-inch thick mattresses. call James A. Racin (see Chapter 4 herein for phone #)

- 13 Blodgett, James C., *Rock Riprap Design for Protection of Stream Channels Near Highway Structures, Volume 1 - Hydraulic Characteristics of Open Channels*, USGS Report 86-4127, US Department of the Interior, US Geological Survey, Water Resources Investigation, 1986.
- 14 Blodgett, James C. and McConaughy, C.E., *Rock Riprap Design for Protection of Stream Channels Near Highway Structures, Volume 2 - Evaluation of Riprap Design Procedures*, USGS Report 86-4128, US Department of the Interior, US Geological Survey, Water Resources Investigation, 1986.
- a page 39 erroneously states that California design method as documented in Reference 1 recommends doubling mean velocity for impinging flow, whereas it actually recommends a factor of 4/3
 - b page 86 erroneously presents California Bank & Shore gradations as "percent finer". several other publications make same mistake when citing California riprap gradations. CA standard gradations actually are PERCENT LARGER THAN (that is, PERCENT RETAINED)
 - c Caltrans contracted with Blodgett to expand his Table 7 on page 55 to include "RSP design method", however, we only used one of his sites in our field evaluation: I-5 & Santiam River near Albany in Oregon, our "Site 15"
- 15 Blodgett, James C. and McConaughy, C.E., *Rock Riprap Design for Protection of Stream Channels Near Highway Structures, Volume 3 - Assessment of Hydraulic Characteristics of Streams at Bank Protection Sites*.
- a project not completed, no publication
- 16 Brown, Scott A., *Streambank Stabilization Measures for Highway Engineers*, FHWA/RD-84/11, Federal Highway Administration, July, 1985.
- a principal author of "new" HEC-11
- 17 Oregon Department of Transportation, *Keyed Riprap*, Federal Highway Administration, Region 15, Arlington VA 22201, distributed through Demonstration Project No. 31, circa 1975.
- a construction technique is to compact rock into a tight mass by dropping a steel plate (about 4-ft x 4ft x 6-in) 4000-lb or heavier from about 3 to 4 feet
 - b keyed riprap requires a rock gradation with a larger percentage of heavier rock sizes, because during plating larger rock fractures
 - c keyed produces greater stability on slopes than loose riprap construction method of old HEC-11 (Reference 3)
 - d smoother hydraulic surface than loosely placed rock before plating operation
 - e most individual rocks are keyed into filter backing material. good stability as contrasted to walking on loose riprap, which is frequently very unstable and characterized by random "rocking rocks" that wobble when walked-on
 - f requires close inspection of grading and layer placement during construction

- 18 Searcy, James K., *Design of Roadside Drainage Channels, Hydraulic Design Series No. 4*, US Department of Transportation, Federal Highway Administration, May, 1965.
- a principal author of "old" HEC-11
 - b this 12/73 reprint has updated references
 - c concur with following statements from Preface:
"Principles and procedures are explained, but no set of rules can be furnished which will apply to all of the many diverse combinations of topography, soil, and climate that exist where highways are built. Design of roadside channels will continue to require an engineer well versed in hydraulic theory and in highway drainage practice."
 - d information on relevant variables, method comparisons (to date of reprint)
 - e besides riprap design, hydrology & hydraulics is presented
 - f page 33 erroneously cites California Bank & Shore factor for impinging flow as 2x mean velocity. correct factor is 4/3 or 1.33x mean velocity. Reference 44 suggests 1.5x or 1.6x mean velocity based on near-prototype flume studies
- 19 Chen, Yung-Hai and Anderson, Bradley A., "Methodology for Estimating Embankment Damage Caused by Flood Overtopping", *Transportation Research Record 1151*, Transportation Research Board, 1987.
- a field studies include some Western states
 - b computer program & nomographs
 - c highway embankment failure mechanisms
 - d laboratory flume studies of riprap, "geoweb", "enkamat", gabion, soil cement, and grass channels
- 20 Fulton-Bennet, Kim and Griggs, Gary B., *Coastal Protection Structures and Their Effectiveness*, Marine Sciences Institute of University of California at Santa Cruz & California Department of Boating & Waterways, 1986.
- a case histories tabled on p. 47
 - b probable failure mechanisms described
 - c based on cited references, many of these sites might have been designed by US Army Corps
 - d good graphics & photos
- 21 Copp, Howard D. and Johnson, Jeffrey P., *Riverbed Scour at Bridge Piers*, WA-RD-118.1, Washington State University and Federal Highway Administration, June 1987.
- a specific for scour at bridges, but good information on field assessment criteria & variables

- 22 Corry, M.L., Thompson, P.L., Watts, F.J., Jones, S.J., and Richards, D.L., *Hydraulic Design of Energy Dissipators for Culverts and Channels*, *Hydraulic Engineering Circular No. 14*, HEC-14, September, 1983.
- a riprap basins
 - b preface & references cite possible contacts for evaluation of tests
 - c design examples x-referenced to Bureau of Reclamation & others, see Chapters III & VII
- 23 Brice, J.C., *Stream Channel Stability Assessment*, US Geological Survey Menlo Park CA and Federal Highway Administration, January, 1982.
- a guide for field assessments of stream morphology & stability of natural channels
 - b examples of reading aerial photos & stream changes
- 24 Lane, Emery W., "Design of Stable Channels, Paper No. 2776", *Transactions of the American Society of Civil Engineers*, ASCE Vol 120, ASCE, 1955 pp 1235-1279.
- a US Bureau of Reclamation's preliminary research & future investigations
 - b tractive force theory, scour, limiting velocity, design of unlined channels
- 25 Wang, Sany-Yi and Shen, Hsieh Wen, "Incipient Motion and Riprap Design", *Journal of Hydraulic Engineering*, ASCE, Vol 111, No 3, ASCE, March, 1985.
- a Shields diagram, incipient sediment motion criteria
 - b compares threshold sediment motion criteria to Corps, CA Bank & Shore, & FHWA projects (energy dissipaters)
- 26 Jarret, Robert D., "Hydraulics of High-Gradient Streams", *Journal of Hydraulic Engineering*, ASCE, Vol 110, No 11, November, 1984.
- a Manning's roughness coefficient n field measured
 - b analysis shows n versus depth as inverse function
- 27 Institution for Civil Engineers, *Shoreline Protection*, Great Britain, Thetford Press, 1983
- a coastal protection in Great Britain
- 28 draft AASHTO Drainage Manual, Bridge Chapter, cover letter from AASHTO drainage committee member A. Mainard Wacker to Tom Debo (author of draft), April 20, 1988.
- a riprap as a bridge scour countermeasure recommends well-graded rock, reverse filter, or geotextile to prevent loss of fines
 - b draft pages 44-50 (pencilled in) present two stone size selection procedures for arresting local scour: critical velocity & clear water
 - c J. Sterling Jones' work with RSP & bridge piers (JSJ former chairman, Transportation Research Board Committee A2A03 Hydrology, Hydraulics, & Water Quality)

- 29 Gamble, James and Mearns, Ron, *Investigation of Rock Slope Protection Material*, Materials & Research Department, Transportation Laboratory, California Division of Highways, April, 1967.
 - a "old" test sites still accessible in CA
 - b assessed methods for durability testing & recommended current tests in section 72 of Caltrans *Standard Specifications*, 1995 and earlier
- 30 Keown, Malcolm P., *StreamBank Protection Guidelines for Landowners and Local Governments*, US Army Corps of Engineers, Waterways Experiment Station, Vicksburg, MS, October, 1983.
 - a layman's description of riprap design pp 37-39, example 404 permit in appendix
- 31 Alaska DOT, *Application of Geotextiles in Alaska*, FHWA AK-RD-84-07, August, 1983.
 - a case study of riprap & geotextiles
 - b should be re-evaluated, factors other than fabric are significant
- 32 Moses, Thomas L. Jr. and Livingston, Harold, *Product Evaluation for Armorflex & Armorform Erosion Control Systems*, AK-RD-85-32, Alaska DOT, February, 1985.
 - a failure mechanisms well-documented, applicable, but not riprap
- 33 Wang, Sany-Yi and Shen, Hsieh Wen, "Analysis of Commonly Used Riprap Design Guides Based on Extended Shields Diagram", *Transportation Research Record 950*, Transportation Research Board, 1984.
 - a recent research, "paper" study, no field verification
 - b sizes of RIPRAP recommended by USACE & CA are larger than incipient motion criteria for "non-motion region" of extended Shields diagram, turbulent flow not studied
- 34 Stevens, M.A. and Richardson, E.V., "Riprap Stability Analysis", *Transportation Research Record 950*, Transportation Research Board, 1984.
 - a recent research, compares several RIPRAP design methods: BPR, USACE, CA B & S, HEC-11, ASCE Task Committee on Sedimentation, et al
 - b cite using "plastic filter cloth" (Calhoun, Highway Research Record 373, 1971)

- 35 Tilton, G.A. Jr., Rowe, R.R., Woodin, C.F., et al, *California Culvert Practice*, 2nd edition, California Department of Public Works, Division of Highways, about 1953.
- a 1st printing June, 1944. these 3 co-authors et al also on "Joint Bank Protection Committee" and guided riprap design philosophy and recommendations of Reference 1
 - b Chapter 1 "Hydrology" presents concepts of "Design Flood Estimates", "Weather Cycle Conclusions", "Misconceptions of Frequency", etc, and recommendations for practicing engineers in California. same concepts applied to riprap design in first edition of Reference 1
- 36 Bowers, H. Dana, *Erosion Control on California State Highways*, California Division of Highways, (published about 1943-1953, Earl Warren was governor)
- a control of slope erosion
- 37 Richardson, Dr. E.V., Harrison, Lawrence J., and Davis, Stanley R., *Evaluating Scour at Bridges, Hydraulic Engineering Circular No. 18*, FHWA-IP-90-017 HEC-18, Federal Highway Administration, Washington D.C., February, 1991
- a HEC-18 replaces "Interim Procedures for Evaluating Scour at Bridges", FHWA Technical Advisory 5140.20
 - b well-organized approach for "assessing the whole" in Appendix E, page E-4
 - c flow chart of scour evaluation, Appendix D
 - d design examples in main text have excellent commentary
- 38 Carlson, E.J. and Enger, P.F., *Studies of Tractive Forces of Cohesive Soils in Earth Canals, HYD-504*, Dept of Interior, Bureau of Reclamation, Division of Engineering Laboratories, Hydraulics Branch, Denver CO, October 19, 1962
- a soil properties from 46 canal reaches: critical tractive force (CTF) values from hydraulic erosion machine, liquid limit, plasticity index, soil density, percent maximum Proctor density, shrinkage limit, soil gradation (log probability), unit vane shear values
 - b CTF more precise criteria than limiting velocity (see E.W. Lane, Reference No. 24)
 - c example problems solved for canal design
- 39 Bertle, Frederick A., *Effect of Snow Compaction on Runoff From Rain on Snow, EM-35*, Department of Interior, Bureau of Reclamation, Washington DC, June 1966.
- a effect of rain on snow of interest for flood control strategies & design of hydraulic structures in Western states
 - b calculations show EM-35 procedure for 1955 flood South Yuba River near Cisco, CA

- 40 Glover, R.E., *Ground-Water Movement, EM-31*, Department of Interior, Bureau of Reclamation, Denver, CO, after 1960
- a analysis, calculations, assumptions, limitations, of a variety of groundwater (GW) problems: drawdown, seepage, return flows, pump depletions, estimates of permeabilities for selecting pump capacities
 - b solutions based on Dupuit-Forchheimer idealization (gradient at water table is effective through saturated thickness of confined aquifer)
 - c solutions compared to Laplace formulation ($q_{in} = q_{out}$)
 - d simplifying assumption: neglect effect of drawdown on available areas for GW flow, then differential equations are identical to those which describe heat conduction in solids
- 41 Brater, Ernest F. and King, Horace Williams, *Handbook of Hydraulics for the Solution of Hydraulic Engineering Problems*, 6th edition, McGraw-Hill Book Co., San Francisco, CA, 1976.
- a fundamentals to solve hydraulic problems, many tables, graphs, computer techniques
 - b lots of numerical examples, some "flow charts" for computer programming
 - c section 7 Steady Uniform Flow in Open Channels
 - d section 8 Open Channels with Nonuniform Flow
 - e Wave Motion & Forces, Energy Dissipation 10-21. beach erosion calculations, wave run-up & overtopping 10-37, shore-erosion control 10-57
 - f section 11 Spatially Variable and Unsteady Flow ... a lot more
- 42 Jennings, Paul C. and Brooks, Norman H., *Storms, Floods, and Debris Flows in Southern California and Arizona, 1978 and 1980*, Committee on Natural Disasters & Environmental Quality Laboratory, California Institute of Technology
- a good discussions of site specific (factual) reports of flood events by various agencies. suggested ways to prevent future loss (USGS, USACE, CA DWR)
- 43 Maynard, Stephen T., *Stable Riprap Size for Open Channel Flows*, Technical Report HL-88-4, US Army Corps of Engineers, Waterways Experiment Station, Hydraulics Laboratory, Vicksburg, Mississippi, 1988.
- a via flume data, riprap sizing method based on average local velocity, depth
 - b uses D30 as best size for describing riprap gradation uniformity
 - c using a constant Shield's coefficient in critical shear stress relations is not valid for high relative roughness, also logarithmic velocity laws are not valid in situations of high relative roughness
 - d thicker riprap layers allows reduced rock size, shape effects of tested rock not significant in additional thickness (round rocks not used, see Reference 44) reducing size & increasing thickness is not recommended according to References 45 and 46 (Reference 46 actually cites 45)
 - e a sizing nomograph & example are presented
 - f gives smaller rock sizes for rivers with mild gradients, like Sacramento River

- 44 Maynard, Stephen T., *Riprap Stability: Studies in Near-Prototype Size Laboratory Channel*, Technical Report HL-92-5, US Army Corps of Engineers, Waterways Experiment Station, Hydraulics Lab, Vicksburg, Mississippi, 1988.
- a further investigation of method reported in reference 43 and in Maynard, Ruff, and Abt "*Riprap Design*", *Journal of Hydraulic Engineering, American Society of Civil Engineers*, Vol 115, No. 7, pp 937-949
 - b RTF (riprap test facility built) at WES to address lack of systematic data in bend & side slope studies done at CO State University flume
 - c tested rock size in bends, riprap thickness, packing effects, round rock, filter type & stability
 - d design procedure based on local depth-averaged velocity
 - e riprap thickness should be minimum $1.5 \times D_{50}$ or $1 \times D_{100}$, whichever yields a larger thickness
- 45 Coastal Engineering Research Center, *Shore Protection Manual, Volumes I & II*, fourth edition, US Army Corps of Engineers, Waterways Experiment Station, Vicksburg, MS, 1984.
- a earlier edition was 1977. this edition has metricated cross section drawings
 - b Volume II section 7 presents discussions & equations for various coastal protection facilities, see page 7-247 for ocean shoreline revetments
 - c because of variability of conditions, shore protection analyses are complex, therefore use experience & engineering judgement
- 46 California Department of Transportation (Caltrans), *Highway Design Manual*, Chapter 870, Channel and Shore Protection - Erosion Control, Office of State Highway Drainage Design, Caltrans, Sacramento, CA, 1992 edition has US customary units, July 1995 edition has SI units (metric).
- 47 California Department of Transportation (Caltrans), *Standard Specifications*, Section 72-2 "Rock Slope Protection", & Section 88-1.04 "Rock Slope Protection Fabric", Caltrans, Sacramento, CA, 1992 edition (US customary units), July 1995 edition (SI units).
- 48 California Department of Transportation (Caltrans), *Standard Plans*, Caltrans, Sacramento, CA, 1992 edition (US customary units), July 1995 edition (SI units, metric).

- 49 Racin, James A., *Gabion Facilities Along the Pacific Coast Highway*, FHWA-CA-TL-93-17, California Department of Transportation, Transportation Laboratory, Sacramento, CA, June 1993
- a two 8-ton RSP revetments were built using geotextile and 1-foot high PVC-coated gabion mattresses as backing and inner layer to reduce total thickness of revetment from 16 to 9 feet thick
 - b as-designed rock maximum size was 6-ton, but field measurements of revetment rocks revealed about 20 percent of individual rocks were 8-ton
 - c one revetment in shoal water condition, while the other in deep water
 - d observed storm wave heights greater than 20 feet
 - e site will be re-evaluated and reported again about 1999, study F93TL02 S
- 50 1-Borgeld, Jeffry C., 2-Scalici, Michael J., and 3-Lorang, Mark, *Mad River Mouth Migration, Monitoring Report*, May 1993.
- 1-Department of Oceanography, Humboldt State University, Arcata CA
 - 2-College of Natural Resources & Sciences, Humboldt State University
 - 3-College of Oceanography, Oregon State University, Corvallis OR
- a geologic and oceanographic data, surveys since about 1854
 - b historical review of Mad River morphology
 - c changes associated with RSP
 - d estuary and tidal prism study
- 51 1-Borgeld, Jeffry C., 2-Scalici, Michael J., and 3-Lorang, Mark, 3-Komar, Paul D., and 4-F.G. Alden Burrows, *Final Project Evaluation Report: Mad River Mouth Migration*, July 1993.
- 1-Department of Oceanography, Humboldt State University, Arcata CA
 - 2-College of Natural Resources & Sciences, Humboldt State University
 - 3-College of Oceanography, Oregon State University, Corvallis OR
 - 4-Department of Environmental Engineering, Humboldt State University
- a Humboldt Bay wave and beach sampling
 - b Mad River estuary dynamics
 - c Mad River inlet dynamics & migration, including conceptual model of inlet hydrodynamics, alignment of inlet with fault trace
 - d conclusions on p. 71 state RSP is stable, only localized movement of rocks.
comment by Racin: Flexibility is normal, rock movement is expected in RSP. 1992 Mad River RSP designed & built with greater than standard thickness. Additional rock launches as toe & face erode by combined action of river & ocean. Launched rock armors scoured voids. RSP turns river flow westerly to ocean. There was about 100 yards of beach erosion beyond west-turn northerly end of 1992 RSP, but by May 1995 eroded pocket has stabilized & reached equilibrium. In 3 years sand dune at south end of 1992 RSP eroded, so contract let for 1000 feet of RSP upstream along toe of slope, completed in May 1995, no natural rock outcrops to tie into. Some erosion at 1995 southerly RSP terminus, but localized to about 100 yards.

- 52 Scalici, 2-Michael J., Mad River Mouth: *Monitoring Report Appendices, Historical Review of the Events Shaping the Mad River Delta and Estuary, Northwest California: 1850-1941*, May 1993, Humboldt State University, Arcata, CA.
- 53 Jennings, M.E., Thomas, W.O., and Riggs, H.C., *Nationwide Summary of US Geological Survey Regional Regression Equations for Estimating Magnitude and Frequency of Floods for Ungaged Sites*, 1993, USGS Water Resources Investigations Report 94-4002, Reston, VA, 1994.
- a comes with a computer disk for DOS-based machines
 - b summarizes techniques and regression equations for all states
 - c state maps shown with flood frequency boundaries (CA has six regions)
 - d has method for estimating "Extreme Flood", including the 500-year flood
 - e discusses testing and validation of techniques, applicability and limitations
- 54 Waananen, A.O. and Crippen, J.R., *Magnitude and Frequency of Floods in California*, USGS/WRI 77-21, US Geological Survey, Menlo Park, CA, 1977.
- a nomographs and equations for peak flows from natural drainage areas (2 to 10 square miles) used by Caltrans and others who design drainage features for transportation facilities. Rational method ok for very small watersheds, but recommended limit is 1/2 square mile per CA Highway Design Manual, and AASHTO is 200 acres, because when used for larger areas, peak flows are overestimated
 - b method and examples for gaged and ungaged watersheds in six climatic regions of CA, recurrence interval 2 to 100 years
 - c equations and nomographs use data from 778 stations: drainage area, mean annual precipitation, precipitation intensity index, mean annual potential evaporation, main channel slope and length, altitude index, surface storage index, and forest cover index
 - d 705 natural, unregulated streamflow stations used to develop regression equations and 275 unregulated, natural short term (15 years) records for small watersheds less than 10 square miles
 - e discussion and guide for augmenting results of regression equations for effects of urbanization, fires, logging, farming practices, mudslides, debris flows, backwater and ponding
 - f until equations are updated to reflect changes in land use in CA, especially suburban and urban development since 1977, design engineers and consultants have been using Soil Conservation Service's method TR-55 (urban watershed modeling) or Corps method HEC-1 (floodplain modeling, urban or rural). Both methods use computer software and both should be verified or validated. Some consultants use HEC-1 for highway drainage applications.

- 55 Denver Urban Drainage and Flood Control District, *Urban Storm Drainage Criteria Manual, Volume 2*, Denver, Colorado, 1982 with May 1984 revision.
- a design equations & criteria are site-specific for Denver area drainages. call 303-455-6277 (OK in Dec. 1995) about purchasing & obtaining Manual & revisions from:
 - Denver Urban Drainage & Flood Control District
 - 2480 West 26th Ave., Suite 156-B
 - Denver CO 80211
 - b 1984 revision includes a safety factor for riprap design, Major Drainage, Section 5, "RIPRAP"
 - c rock sizing based on velocity & channel slope per model studies by C.D. Smith & Murry of Canada
 - d five standard riprap classes & gradations (very similar to CO DOT): Type VL (very light), Type L (light), Type M (medium), Type H (heavy), & Type VH (very heavy). In populated urban neighborhoods, VL & L must be covered with soil & revegetated to discourage vandalism
 - e thickness criteria: for river & stream bank slopes 1.75xD50, for toes 3xD50
- 56 Mendrop, Kelly B. and Little, Jr., Charles D., (both P.E.'s for US Army Corps of Engineers, Vicksburg District, MS), *Grade Stabilization Requirements for Incised Channels*, pp. 181-193, Proceedings of Conference XXVII, Erosion Control Technology...Bringing It Home, International Erosion Control Association, Steamboat Springs, CO, 1996.
- a System or basin-wide approach: hydraulic and geotechnical stability criteria are developed as basis for planning and designing erosion control features. seven general steps are:
 - 1 identify system-wide and site-specific problems
 - 2 determine basin history - get past and current basin data
 - 3 investigate channel & basin stability in field
 - 4 assess geomorphic data of 2 & 3 for comprehensive view of system, including rates of change
 - 5 develop hydraulic & geotechnical stability parameters for channel reaches
 - 6 assess total system stability
 - 7 determine need for various types of rehabilitation measures. schedule, & implement to optimize rehabilitation of total watershed
 - b Demonstration Erosion Control (DEC) projects in upper Yahoo River Basin, northern MS show that among the first kinds of projects to be implemented are hydraulic grade control measures, where channel incision is prevalent
 - c Grade control structures and riprap for incised channels and meander control sites were field-evaluated by Little, Maynard, & Racine in 1993, as part of the "RSP Research" reported herein. see photos C-53 through C-60 in Appendix C and Table 7-1 Sites 32 through 49 herein

- 57 Caltrans Office of Structural Foundations, edited by Keith E. Swanson and Richard Fox, *Soil & Rock Logging Classification Manual (Field Guide)*, Caltrans Engineering Service Center, Sacramento, CA, Interim Final Report, December 1995 (final available by July 1996).
- a concise field guide based on Unified Soil Classification System and Oregon DOT's "Soil and Rock Classification Manual"
 - b developed to help get precise & meaningful soil descriptions. encourages using consistent terminology for a rock description system, which is relevant to geologic and geotechnical design and construction
 - c page 6 section 1.8 "Typical Shapes of Bulky Grains" applies to shapes of riprap (rock of RSP-Classes, see Table 5-1 herein for size and gradations)
 - comment by Racin: Section 72-2.02 of Caltrans Standard Specifications (in Appendix B herein & Reference 47) limits slope to 1V:2H for rounded rock shapes on prepared (planar) slopes. conservative guideline: do not allow rounded rock on prepared (planar) slopes steeper than 1V:2.5H
- 58 US Army Corps of Engineers Omaha District, *Interim Field Evaluation of Windrow Revetment*, Missouri River Section 32 Streambank Erosion Control, USACE, Omaha, Nebraska, March 1980.
- a windrow test reach downstream of confluence of Vermillion Missouri Rivers
 - b successful demonstration project stabilized farmland. done by authority of "Streambank Erosion Control Evaluation and Demonstration Act of 1974, Section 32, Public Law 93-251"
 - c dam controlled releases range from 15,000 to 80,000 (100-year) cfs
 - d formerly uncontrolled reaches degraded due to "clear water scour"
 - e river plan form is sinuous, adjacent farmland banks undercut & sloughed
 - f study reach monitored for 3 years from 1976 to 1979
 - g report thoroughly documents agricultural land use, hydrology, hydraulics, design, construction, model studies, (photographs, charts, plates, cross sections, discharge & velocity measurements)
 - h windrow riprap
 - 1) trench excavated parallel to bank line, at top of 20-foot high bank next to 20-foot deep reach of river
 - 2) windrow trench 16-feet wide x 6-feet deep x 2070-feet long. 9321 tons placed originally, 4.5 tons/lineal foot, (materials, labor & installation \$42/lineal foot of bank line). impinging bank needed extra 1.5 tons/lineal foot (4-feet deep x 8-feet wide x 375-feet long, \$25/lineal foot of bank line)
 - 2) graded fieldstone placed in trench (fieldstone size appears similar to Caltrans RSP-Class Backing No. 1 or No. 2 per Photograph 12)
 - 3) stone covered with shallow lift of soil, area reseeded with grasses (replacement in kind, farm land cleared of trees for agricultural use)
 - 5) as toe undercut, rock in windrow sloughed, bank stabilized, riparian growth regenerated naturally, provided improved habitat & aesthetic value to previous bank

Chapter 9. Personal Communications

Communications were both written and oral from about 1990 through 1996. The majority are licensed engineers. Field reviewers are listed in bold print; they field-reviewed at least one of the sites in Table 7-2 with one or more of the authors.

Caltrans District Maintenance Engineers, Superintendents & Regional Managers 1

- Len Bloomquist
- 2 Mike Rose, Frank Herman, Milt Apple, Jim Fitzpatrick
- 3 Dick Melim, Joe Cena, N. Butts, R. Williams, Bill Netto, John Cottier, Ron Lecroix
- 4 Jerry Hauke, Joe Battaglini, Jack Eslick, J.T. Anderson, Chuck Smith
- 5 Herb Filipponi
- 6 Richard Beck
- 7 Dick Kermode
- 8 Bob Karns
- 9 Satish Chander
- 10 Bill Gilmore, Bill Selling, Louis Kuntz, Earl Williams
- 11 Stu Harvey
- 12 Joe Hecker

Caltrans District Hydraulic Engineers

- 1 **Dennis McBride, Charlie Fielder**, Ralph Martinelli, **John Bulinski [Dan Wing, Dennis Grinzel**, Carlos Portillo (construction)], Mark Moore (biologist)
- 2 Susan Wilson-Broadus
- 3 Palmer Haug, Dennis Jagoda, Jeff Hollstein
- 4 Joe Peterson, W.B. Lee
- 5 Steve Hendricksen, **Lance Gorman**
- 6 Richard Schumaker, Todd George
- 7 William Lum, Ralph Sasaki, Harry Hung
- 9 Richard Kizer, Truman Denio, Bruce Swanger
- 10 **Don Lane** (construction)
- 11 Cid Tesoro, Karen Jewel
- 12 Raouf Mousa, Dave Bhalla
- HQ [Fred Boucher, **John Wright** (retired)], **Carroll Harris** (deceased), **Steve Nakao, Bill Lindsey**, Joe Cerna, Paul Davies, Dawn Foster, Glenn DeCou

Caltrans District Materials Engineers

- 1 Drew Irwin
- 2 Bob Wenham
- 3 Shaun Rice
- 4 E.R. "Skip" Sowko
- 5 Ron Richman
- 6 Bob Voss
- 7 Don Higuchi
- 8 Sam Ponder
- 9 Mike Carrington
- 10 Jim Hall
- 11 Bill Valle
- 12 Badie Rowshandel

FHWA Hydraulic Engineers
Washington D.C. J. Sterling Jones
Region 8 Larry Arneson (and Geotechnical Engineer, Barry Siel)
Region 9 Arlo Waddoups
Region 10 **Christopher N. Dunn**

US Army Corps of Engineers (USACE), Hydraulics WES Vicksburg MS
Dr. Stephen T. Maynord

Simons and Associates, Inc.
Dr. Daryl B. Simons

US Department of the Interior, US Geological Survey
James Blodgett (retired)

USACE, Seattle District WA
Dick Burnahm, Construction
Jim Lencioni, Hydrology and Hydraulics
Lester E. Soule, Civil Projects

USACE Vicksburg District MS
Charles D. Little, Jr.

USACE Sacramento District CA
Paul W. Bowers and Bob Kelly

Colorado State University & ASCE Hydraulics Division
Dr. Steven R. Abt

Humboldt State University CA, Geology Department
Dr. Gary A. Carver

Oregon DOT, Bridge Hydraulics Engineer
Dave Bryson

Denver Urban Drainage and Flood Control District CO
Ben Urbonas, Barbara Benik, Frank Rosso

Colorado DOT
Hydraulic Engineers, **Gary Johnson** and **Rick Moser**

Snowmass Village, CO
Landscape Architect, Erosion Control Specialist, **John McCarty**

Appendix A. Example Problems

The following three problems show how to design RSP by the CA Bank and Shore method, a LAYERED method. The problems are ideal in the sense that velocity data are given. Besides velocity and stone-sizing equations, the solutions illustrate the riprap design process, which is typical in Caltrans practice. Problem A-1 (with Figures A-1 and A-2) illustrates a typical design for impinging flow, and it demonstrates that "bank-full design discharge" does not always result in the worst case for bank protection design. Problem A-2 (with Figures A-3 and A-4) illustrates a typical design for parallel flow, and it demonstrates the incorporation of cover soil in the RSP design for planting, which can restore habitat and can produce shade. Typical and alternate cross sections of Figures A-1 through A-4 depict *flexible* RSP designs, where flexible means "only rock".

Although not the primary focus of this investigation, problem A-3 (with Figures A-5 and A-6) illustrates the design of *rigid* concreted-RSP. Concreted-RSP eliminates some inner layers of rock, which gives a thinner cross-section than a comparable flexible section. Concreted-RSP is used where hydraulic width is critical, in narrow channels and on some bridge abutment fills. Also when only small rock is available, concreted-RSP is an option. Concrete binds small rock into larger pieces. While concreted-RSP is rigid, it is not intended to be impervious, and therefore water behind the revetment must have pathways back to the channel via weep pipes or intervals where concrete is intentionally omitted. Concreted-RSP can be built to fracture and fall into scoured zones. Willows can be successfully grown through concreted-RSP, as long as cuttings are placed among rock voids before concrete is placed; see Photo C-48 and caption.

Problem solutions and figures are in US customary units for the convenience of designers, who will likely use as-built plans that are in US customary units. SI (metric) units were excluded from the figures to present an uncluttered appearance. However, SI (metric) units are shown in parentheses in the text of solutions. Figures A-1 through A-6 are problem-specific; they are **not** standard plans. Because of the range of possible layers, rock sizes, and geotextiles, a standard plan is not feasible. Therefore, generic cross sections are presented in Figures A-7, A-8, and A-9.

For protecting banks, there are other materials with different degrees of flexibility and responses to scour. Some are: gabions, cable-stayed (articulated) concrete blocks, interlocking concrete blocks, and concrete-filled fabrics. Example problems for these latter materials were beyond the scope of this investigation.

Problem A-1 Impinging Flow. Along a rural highway 250 feet (76.2 m) of riprapped embankment and portions of roadway shoulder washed out. A signal for one-way traffic was set up. Investigate and recommend reconstruction.

Solution.

- 1 (Chapter 5, Section 5-1-A). As-built plans show that the roadway/riverbank was armored five years ago (before metrication) with a layer of METHOD B *Backing No. 1* RSP, 1.8 feet thick (550 mm), face slope angle 1V:1.5H. The toe was embedded 3 feet (915 mm) below the riverbed. There was no RSP-fabric or layer of permeable filter backing material. The RSP extended from the hinge point to the riverbed. The bank-full channel depth for a Q50 event is 15 feet (4.57 m). Design records show the *Backing No. 1* RSP was sized by using a parallel flow condition and bank-full mean velocity of 15 fps, feet per second (4.57 m/s).
- 2 (Chapter 5, Section 5-1-B).
 - 2a Field review during low flow revealed the following information. Exposed roadway embankment is sand and silt. Several pools along the toe of the failed bank were probed with a 6-foot length of rebar. Through loose sand and silt, rocks were felt about 4 feet (1.22 m) below the river bed, which suggests armored scour holes. Flow is parallel at bank-full stage. An island of stone, gravel, and some vegetation was opposite and upstream of the failed bank. Apparently the island caused flow to impinge on the failed bank when the water was one-third bank-full stage and less. Field measurements and flow calculations at one-third bank-full stage gave an average velocity of 11.5 fps (3.51 m/s) in the impinging channel. Road and RSP banks upstream and downstream of the failed bank are OK at 1V:1.5H. Silt stains and drift wood upstream and downstream show that river crested about 8 feet (2.44 m).
 - 2b Consulted with local residents and the Caltrans maintenance crew. Flow was steady, and the river stage remained below half-bank-full for about 2 days. On the second day, they observed the failure and described that after the lower bank washed away, the upper bank and shoulder gradually sloughed into the river and washed away.
 - 2c A Fish and Game biologist stated the river has a spring salmon run. They advise no channel leveling and not removing the island. Normally the construction window is from July 1 to October 1, however, an emergency permit will waive those dates pending proposed work and water levels.
 - 2d Hydrologic and hydraulic records show that flow is from spring snowmelt and rain runoff. There are no dams upstream.

- 3 (Chapter 5, Section 5-1-C). Find the minimum stable stone weight using Equation 1, US customary units. For an SI (metric) solution, first solve Equation 1 in US customary units, then soft-convert W to a metric value.

$$\text{Equation 1. } W = \frac{0.00002 V^6 SG}{(SG - 1)^3 \sin^3 (r - a)}$$

3a Increase the velocity for impinging flow: $V = 4/3 \times 11.5 \text{ fps} = 15.33 \text{ fps}$

3b Assume rock specific gravity $SG = 2.65$

3c Angle $a = \arctan (1/1.5) = 33.69 \text{ degrees}$. Angle $r = 70 \text{ degrees}$.

3d Minimum stable stone weight $W = 738 \text{ pounds} (335 \text{ kg})$

- 4 (Chapter 5, Section 5-1-D). See Table 5-1 "Guide for Determining RSP-Class of Outside Layer." Enter left side of table (row labels are standard rock sizes).

4a select 1/2 ton (450 kg), the closest heavier standard rock size greater than the minimum stable stone weight of 738 lbs (335 kg),

4b trace horizontally to the right and locate the "50-100" percent entry,

4c trace vertically upward and read column headings: **1/2 ton (1/2 T)**. Use this as your "first trial" RSP-Class.

4d District Hydraulic Engineer checks as-built plan, profile, and typical sections. A layered 1/2 ton RSP-Class facility was built on bend nearby, about 12 years ago. The site was not seen during field-review. The Maintenance Engineer verified that the site is undamaged and was never repaired. Thus, the "first trial" outside layer RSP-Class is OK, and no further trials are needed.

- 5 (Chapter 5, Section 5-1-E). Using Table 5-2 "California Layered RSP", in column labeled OUTSIDE LAYER RSP-CLASS locate **1/2 ton** entry. Read entries to right:

5a **NONE** in column labeled INNER LAYERS RSP-CLASS means no INNER LAYERS are required.

5b **1** in column labeled BACKING CLASS No. means a layer of *Backing No. 1* is required.

5c **B** in column labeled RSP-FABRIC TYPE means TYPE B RSP-fabric is required.

- 6 (Chapter 5, Section 5-1-F). Using Table 5-3 "Minimum Layer Thickness" in column labeled "RSP-Class Layer" notice there are two entries for **1/2 ton**. Select **B** as "Method of Placement." The slope angle is not too steep for angular rock, and although Method B gives a thicker section, the unit cost is less than Method A.

6a "Minimum Thickness" is **4.3 feet (1.31 m)**.

6b next in column labeled "RSP-Class Layer" locate the only **Backing No. 1** entry. **B** is Method of Placement. Minimum Thickness is **1.8 feet (550 millimeters)**.

6c Add layers, TOTAL THICKNESS normal to slope is **6.1 feet (1.86 meters)**.

6d See Figure A-1. The stage of this event was less than the Q50 design event. The altered channel condition (island) caused impinging flow and the toe failure, leaving armored scour holes 4 feet (1.22 m) deep. Calculated scour is 6 feet (1.83 m). Therefore an EMBEDDED toe trench should be excavated 6 feet (1.83 m) below the riverbed, 2 feet (610 mm) deeper than observed scour holes. Place Type B RSP-fabric and *Backing No. 1* starting in the toe trench and extending upward to the bank-full depth of 15 feet (4.57 m).

Recall field conditions: *Backing No. 1* is OK immediately upstream and downstream. No "leading or trailing" cutoff trenches are needed, because the reconstructed bank will tie into the undamaged banks. Constructing the layer of *1/2 ton (1/2 T) RSP* all the way to the top of the bank is probably not justified at this site. Although the river crested at 8 feet (2.44 m), the *1/2 ton (1/2 T) RSP* should be constructed about 2 feet higher (610 mm) than the impinging channel depth of 5 feet (1.52 m), that is, 7 feet (2.13 m) from the river bed. This is reasonable for debris that could impact the bank. No RSP-fabric should be exposed in the riverbed. Anchor the RSP-fabric at the top of the bank as shown in Figure A-1.

6e An alternative for handling expected toe scour is the MOUNDED toe. Do not excavate a toe trench. Directly on the riverbed, build a mound of rock that has the same cross sectional area as the OUTSIDE LAYER of RSP, which would have been embedded, in this case *1/2 ton (1/2 T) RSP*. The mound of *1/2 ton (1/2 T) RSP* is placed directly on the channel bed and against the layered riprap. Initially, the same thickness (normal to slope) and the same height of toe (EMBEDDED depth in step 6d above) are used, and also the same slope face angle of 1V:1.5H. See Figure A-2.

6f Different dimensions can be used for the MOUNDED toe, as long as the same cross-sectional area of *1/2 ton (1/2 T) RSP* is placed against the layered section of *1/2 ton (1/2 T) RSP*, *Backing No. 1* and Type B RSP-fabric. For different MOUND dimensions, the general solution is:

(6f1) Initial height = EMBEDDED depth in step 6d above

(6f2) Initial base width = outside RSP layer thickness / sin (slope angle)

(6f3) Initial MOUNDED area = Initial base width x Initial height

(6f4) Select trial base width

(6f5) Trial height = Initial MOUNDED area / trial base width

The above procedure is repeated until the geometry of the MOUNDED toe is OK as demanded by river hydraulics (see step 10 of this problem) and by permit agencies.

6g In this problem situation, ends of RSP will be joined to existing RSP upstream and downstream, and the same cross sectional thickness is constructed for the entire length of the facility. That is, the reconstructed layer of Backing No. 1 layer will be flush with the existing upstream and downstream Backing No. 1 and the 1/2 ton layer will protrude.

Flank treatments, also called cutoffs or leading and trailing edges, comparable to cutoff walls, might be needed in other situations. For the upstream flank (leading edge) "New" HEC-11 (Reference 9 pages 42 and 43) suggests in longitudinal profile, a rock stub at least 5-feet deeper than T (total revetment thickness including backing layer) by 1T wide. An additional section of revetment is extended 3T upstream. The depth of the downstream flank (trailing edge) is 2T with a base width of 3T. Site-specific conditions may demand more or less of a cutoff with different geometry, for example, see Photo C-77 and caption. Where there is bedrock or an outcrop, build the revetment right up to the naturally stable material. For example, see Photos C-17, C-81, C-83 and their captions.

- 7 Materials engineer tests rock sources and finds specific gravity of rock is between 2.60 and 2.70, which verifies the assumed values. Thus, it is OK to use Minimum Thickness values from step 6 (Table 5-3) above as the thickness. For RSP-Classes larger than *1 ton (1 T)*, the thickness values should be recalculated if the specific gravity does not closely match the assumed value of 2.65 used in Table 5-3. Other quality requirements of Section 72-2.05 (1995 CA Standard Specifications) were found to be OK.
- 8 Recommended cross section is Figure A-1. In letter to pending resident engineer's file, contractor can salvage clean *Backing No. 1* within plan view limits of failed embankment and proposed toe excavation, but should not attempt to salvage any material that washed into river bed.
- 9 There was no significant prior vegetation on the failed bank, nor immediately upstream or downstream. Therefore, no revegetation is required.
- 10 (Chapter 5, Section 5-1-G). If the design of Figure A-1 is rejected, then submit Figure A-2. Re-calculate river hydraulics with appropriate cross section and future roughness values, assuming the alternate cross section of Figure A-2. Determine if the proposed alternate cross section would significantly increase channel velocity or reduce the

hydraulic capacity. Discuss the proposed designs with engineers and biologists of the permit agency. Some sort of toe is needed. Emphasize that the bank originally failed because the riprapped toe was not adequate, due to altered river channel conditions (the island directed flow at bank). Also, in the permit proposal, submit a sketch showing a temporary berm and geomembrane that will keep possible low-stage river water from getting into the construction zone.

Problem A-2 Parallel Flow. In a suburban setting, formerly rural, flood waters carrying large amounts of natural debris caused the loss of 150 feet of riprapped streambank, shallow-rooted trees, and portions of road shoulder. Repairs and replanting are required. Do an RSP bank protection study and make recommendations for repair.

Solution.

1 (Chapter 5, Section 5-1-A). As-built plans and design records show that the site has parallel flow. Due to upstream development there is increased runoff, mean channel velocity is now 21.5 fps (6.55 m/s) and stage is bank full at 20 feet.

2 (Chapter 5, Section 5-1-B)

2a Field review at site revealed coarse sand, gravel, and rounded cobbles as streambed. Calculated scour is 10 feet (3.05) meters. Flow is parallel to bank for full range of depths. Previous bank protection was *Facing* (same as *Backing No. 1*) and only extended 3/4 bank-full (15 feet).

2b Consulted with residents, maintenance, wardens, biologists, and engineers of permit agencies. Stream flows year-round and is stocked with trout.

3 (Chapter 5, Section 5-1-C). Find the minimum stable stone weight using Equation 1, US customary units. For an SI (metric) solution, first solve Equation 1 in US customary units, then soft-convert *W* to a metric value.

$$\text{Equation 1. } W = \frac{0.00002 V^6 SG}{(SG - 1)^3 \text{ SIN}^3 (r - a)}$$

3a Road embankments upstream and downstream of failed bank are

OK at **1 vertical to 2 horizontal**. Replace RSP at same slope face angle.

3b Use decreased velocity for parallel flow condition: $2/3 \times 21.5 = 14.3$ fps

3c Assumed rock specific gravity = 2.65

3d Minimum stable stone weight $W = 310$ pounds (141 kg)

4 (Chapter 5, Section 5-1-D). See Table 5-1 "Guide for Determining RSP-Class of

Outside Layer." Enter left side of table (row labels are standard rock sizes).

4a Select 1/4 ton (220 kg), the closest heavier standard rock size greater than the minimum stable stone weight of 310 lbs (141 kg)

4b Trace horizontally to the right and locate the "50-100" percent entry,

4c Trace vertically upward and read column heading = **1/4 ton (1/4 T)**. Use this as your "first trial" RSP-Class.

4d Field information from nearby site indicates that 1/4 ton is OK there. District hydraulic engineer confirms 1/4 ton RSP-Class will be OK, based on nearby site that also failed recently due to undersized RSP-Class = *Facing*, (maintenance was doing frequent minor bank repairs). Use 1/4 ton for the OUTSIDE LAYER RSP-Class, no further trials are needed.

5 (Chapter 5, Section 5-1-E). Using Table 5-2 "California Layered RSP", in column labeled OUTSIDE LAYER RSP-CLASS locate **1/4 ton** entry. Read entries to right:

5a **NONE** in column labeled INNER LAYERS RSP-CLASS means no INNER LAYERS are required.

5b **1 or 2** in column labeled BACKING CLASS No. means a layer of *Backing No. 1* or *Backing No. 2* is required. Select *Backing No. 2*, available at quarry.

5c **A** in column labeled RSP-FABRIC TYPE means TYPE A RSP-fabric is required. Note: you can specify 200 mm of *Backing No. 3* instead of TYPE A RSP-fabric.

6 (Chapter 5, Section 5-1-F). Using Table 5-3 "Minimum Layer Thickness" in column labeled "RSP-Class Layer":

6a locate **1/4 ton** entry, then read entries to right: **B** is "Method of Placement" and 3.3 feet (1.00 m) is "Minimum Thickness".

6b next in column labeled "RSP-Class Layer" locate the only ***Backing No. 2*** entry. **B** is "Method of Placement" and "Minimum Thickness" is **1.25 feet (380 millimeters)**.

6c Add layers, TOTAL THICKNESS normal to slope is **4.55 feet (1.38 meters)**.

6d See Figure A-3. Based on scour calculations, toe trench should be 10 feet (3.05 m) below streambed. One possible cross section is Type A RSP-fabric, *Backing No. 2*, and 1/4 ton RSP in toe trench, up roadway/streambank to bank-full depth. Notice that additional RSP-fabric is included as a "soil brake" to limit the downward movement of cover soil and possible leaching into the stream due to fluctuating stages. The "soil brake" RSP-fabric should be placed no lower in elevation than "high water," and it may be placed higher.

- 6e To accommodate possible tree species higher up the bank with deeper root systems than typical riparian species, an alternative cross section with *Backing No. 3* is shown in Figure A-4. Specify 0.75 feet (230 mm) of angular to subangular *Backing No. 3* on typical cross section of contract plans. Write a note and place it in the pending Resident Engineer's file: "Reject *Backing No. 3* if it is rounded river-run, because the 1V:2H slope is too steep for a stable backing. Subangular rock shapes would be OK." See Reference 57 for standard description of particle shapes. The "soil brake" RSP-fabric is still needed.
- 7 Materials engineer tests sources and confirms assumed specific gravity of rock was OK, results ranged from 2.6 to 2.8. Actual shapes and other quality requirements are OK.
- 8 Recommended cross section is Figure A-4, toe trench 10 feet (3.05 m) deep.
- 9 (Chapter 5, Section 5-1-G). Re-calculate stream hydraulics. Discuss with permit and agreement agencies. In permit also propose building a temporary rock berm in the stream with a geomembrane for dewatering to excavate the toe trench.
- 10 Hydraulic calculations were redone for future mature vegetation and found to be OK. For the upper 8-foot zone of the reconstructed RSP above high water, fill voids and cover the 1/4-ton RSP with a layer of cover soil, minimum 4-inches (102 mm). Revegetate with grass, shrub, and tree species similar to those upstream and downstream. Consult with an erosion control specialist or biologist for appropriate species. None of the cover soil or plants are placed lower than "high water," roughly the annual observed elevation that persists from January through the end of March (**for this site in this hypothetical problem**), because the annual flows would wash away cover soil, thereby creating a sediment nuisance in spawning beds. At other sites there may be different definitions or ways of determining "high water."

Problem A-3 Concreted-RSP. At a stream crossing, both approach roadways washed out and an old spread footing centerspan pier foundation failed due to debris impact. A new bridge must pass 17,000 cfs (481.4 cubic meters / second) with debris. The roadway is "sole access" for law enforcement and emergency vehicles to several communities and ranches. The shortest duration alternate route would take 2 hours longer than if the road and bridge were passable. Although the new bridge will have deep pile foundations, the roadway must not be "sacrificed." Therefore, both abutment fills must be protected. The

channel cross section under new bridge will be trapezoidal with 1V:1.5H side slopes. Design depth is 14 feet with 2 additional feet to pass debris. The channel bottom must be kept as a natural sandy bottom. Because the channel is on a bend, flow impinges, and with the likelihood of debris and a historically unstable thalweg, both abutment fills will get the same protection. Average approach velocity is 14 fps (4.23 m/s).

Solution.

First follow steps 1 through 8, similar to Problem A-1. Determine the RSP-Classes for a layered flexible-RSP design. For this problem, suppose step 8 produced a cross-section similar to Figure A-3, with the following layers for one abutment fill:

RSP-Class and Method	thickness in feet (m)
1 ton (1T), B	5.4 (1.65 m)
Light (Light), B	2.5 (0.76 m)
Type B RSP-fabric	---
Total thickness normal to slope	7.9 (2.41 m)
Total base width	14.24 feet (4.34 m), 28.48 feet (8.68 m) for both sides.

- 9 (Chapter 5, Section 5-1-G). A recalculation of stream hydraulics determined that the above layered cross section (for both abutments) constricts flow and increases velocity. Thus, the above flexible-RSP design is rejected.
 - 9a To reduce total thickness of the revetment, determine a concreted-RSP-Class that is comparable to the outside layer of flexible RSP.
 - 9a1) Divide outside RSP-Class by 4 or 5 for a comparable outside layer of concreted-RSP. It is assumed that in time, concreted-RSP will break into 4 or 5 individual pieces.
 - 9a2) 1 ton = 2000 lb, $2000 / 4 = 500$ lb, 500 lb = 1/4 ton
 - 9b Use Tables 5-2 and 5-3 for required layers and minimum thicknesses. Result is 1/4 ton (1/4 T), Backing No. 2 (Backing No. 2), both Method B, and Type A RSP-fabric. [To shorten the explanation, the decreased channel width and velocity are found to be OK. Calculated scour depth is 12 feet (3.65 m)].
 - 9c Figure A-5 is the accepted typical cross section.

- 10 See Figure A-6, Construction Notes for Concreted-RSP.
 - 10a For concreted-RSP weep pipes should be included. Alternatively, concrete may be omitted at regular intervals to create voids for seepage. Until the mass of concreted rock develops fractures, it is necessary to drain water from the backslope, especially in streams with rapidly rising and falling stages.
 - 10b Construction notes are presented in Figure A-6 and should be included in contract plans on a cross section detail sheet. The following comments supplement notes A through G, respectively.
 - 10b 1) Place Backing No. 2 and 1/4 ton RSP both by Method B. Construct rock then place concrete. Typical construction is from low-to-high elevation. Place weep pipes as the layered cross section is built or when it is completed. Do not punch pipes through the RSP-fabric, because bank soil

will ultimately pipe away, leaving voids and the likelihood of bank failure. Just butt the pipes up against the RSP-fabric.

- 10b 2) When perforated weep pipes are used, concrete must be prevented from passing through the perforations. For example, wrap newspaper or a piece of RSP-fabric around the pipe. Do not use waterproofed paper.
- 10b 3) The resident engineer has authority to control water content of the **concrete** mixture. Concrete is placed. If there is excess water, the mixture will **pour** or **flow**, in which case it is really **grout**. A common misnomer is "grouted-RSP". The contract pay item is **concreted-RSP**. Concrete will normally fill voids by gravity, however, it may need to be broomed, tamped, spaded, rodded, or vibrated. It is too wet if it slumps beyond the theoretical "concrete limit line" shown in Figures A-5 and A-6. To prevent concrete from oozing out at the bottom of the slope, limit concrete placement to 2 meters or less vertically. The 3-meter value in Caltrans Standard Specifications section 72-5.04 is excessive.
- 10b 4) Rocks of the outside layer must protrude beyond the "concrete limit line," thereby creating a rough surface for dissipating energy and decreasing velocity. When excess concrete is allowed past the "concrete limit line," it produces a smoother surface. Also, excess concrete can delay or preclude the cross-section from ever fracturing and creating large pieces of concreted-rock, as this kind of design originally intended.
- 10b 5) Similar to step 10b 1), placing concrete should progress from low-to-high elevation, roughly along contours. Section 72-5.04 (1995 Caltrans Standard Specifications) states:
"In no case shall the concrete be permitted to flow on the slope protection a distance in excess of 3 m."
Vertical progress really should be limited to 2 meters (6.5 feet), while roughly following a contour. Cold joints are OK. Again, if the mixture really flows, it is too wet, and it is a grout, not concrete.
- 10b 6) After concrete has cured at least 2 days, newspaper is removed from weep pipes on the stream-side, 2-foot zone with no concrete. This measure is not exact and a tolerance of 6-inches beyond the concrete limit line is OK, however, the excess concrete will not be paid for.
- 10b 7) Whenever possible, it is important to replace the natural materials of the streambed, in a way that nearly replicates the prior condition. Fish passage must not be restricted by any aspect of the completed job. Any revegetation effort should be directed away from the "hydraulic opening" of the bridge, that is, do not plant on the abutment fills under the bridge and through the waterway areal limits, that is, within the channel depth and width between planes perpendicular to bridge ends in plan view. Typically, vegetation that volunteers under bridges is transient; it will be swept away in high flow or high velocity events, then will likely regenerate again naturally.

Figure A-1 RSP Toe EMBEDDED Below Riverbed

Appendix A Problem 1 Typical Cross Section No Scale US customary units

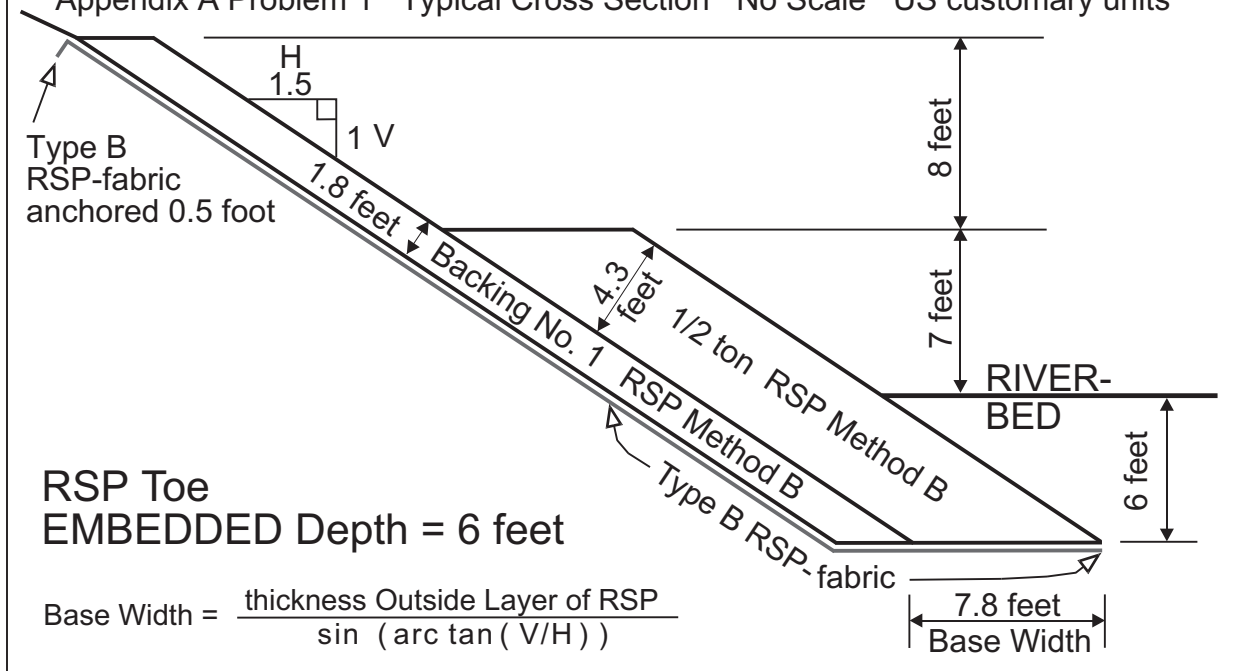
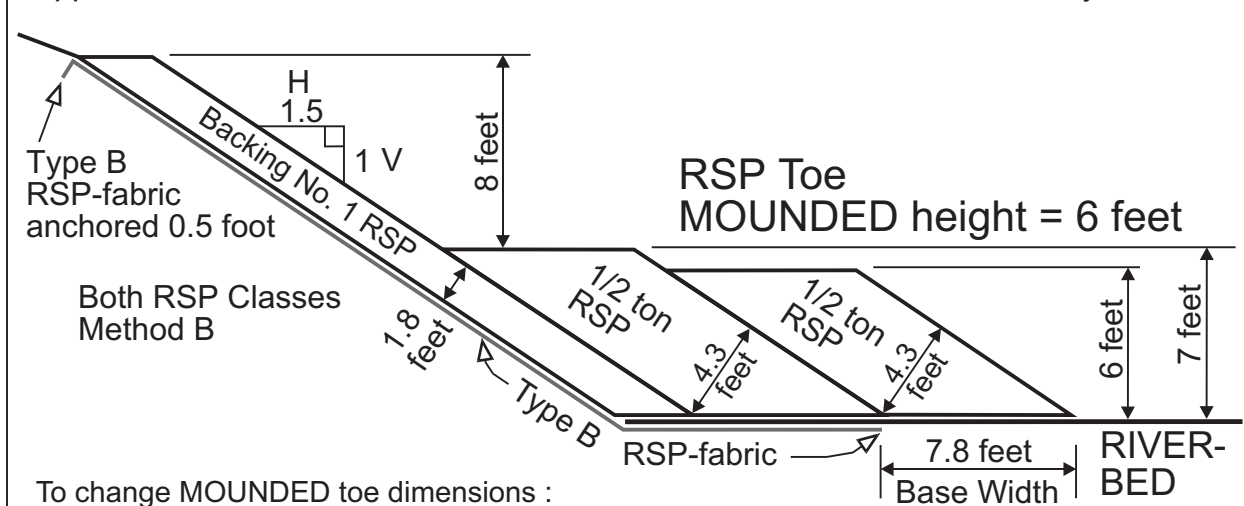

Figure A-2 RSP Toe MOUNDED on Riverbed

Appendix A Problem 1 Alternate Cross Section No Scale US customary units



To change MOUNDED toe dimensions :

1. Initial Height = EMBEDDED Depth in Figure A-1
2. Initial Base Width = Base Width of Outside Layer of RSP in Figure A-1
3. Initial MOUNDED area = Initial Base Width x Initial Height
4. Select trial Base Width
5. trial Height = Initial MOUNDED area / trial Base Width

Figure A-3 Layered RSP With Cover Soil

Appendix A Problem 2 Typical Cross Section No Scale US customary units

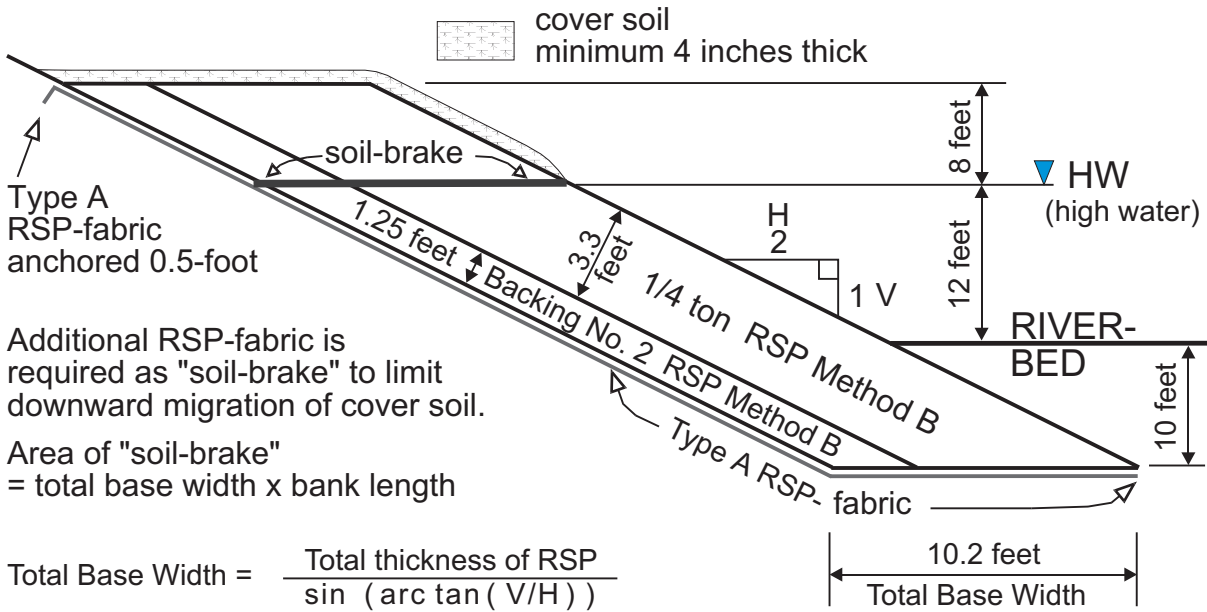

Figure A-4 Alternate Layered RSP With Cover Soil

Appendix A Problem 2 Alternate Cross Section No Scale US customary units

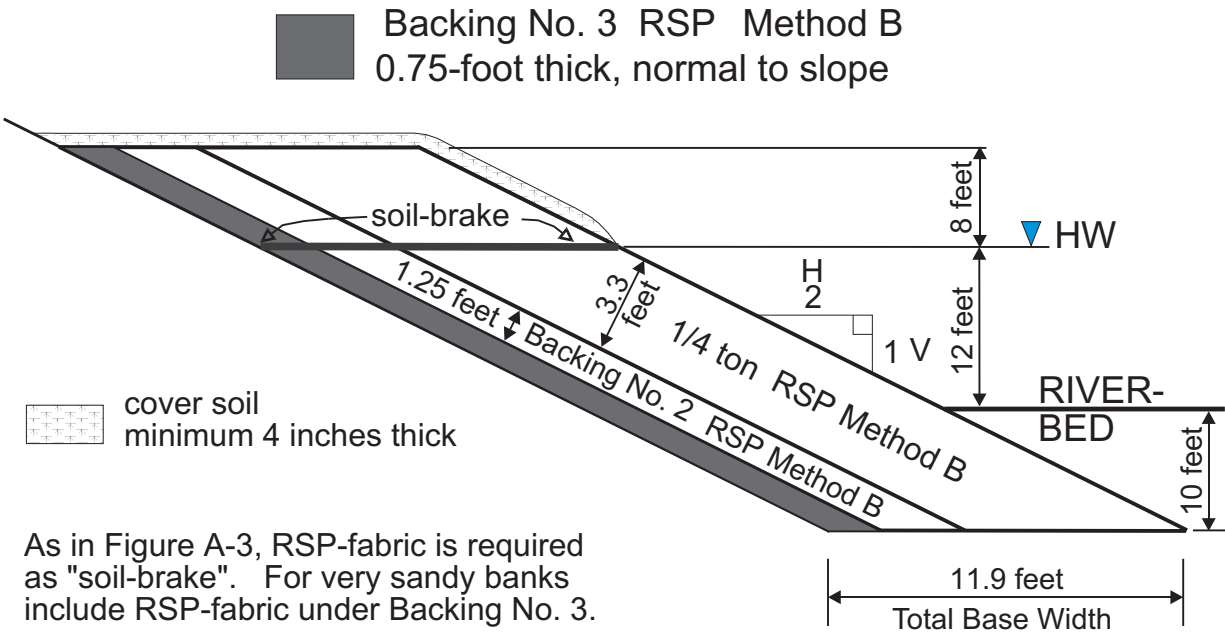

Figure A-5. CONCRETED-RSP with EMBEDDED Toe

Problem A-3 Typical Cross Section No Scale US customary units

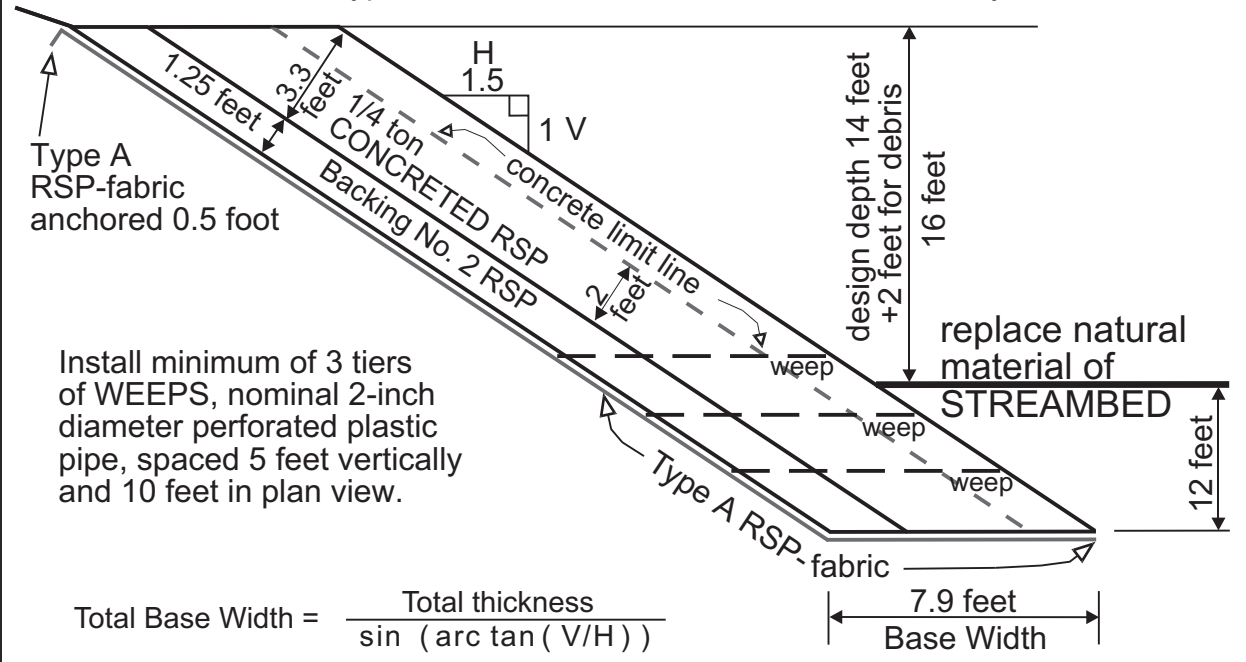

Figure A-6 Construction Notes for Concreted-RSP

A. Backing No. 2 (1.25 feet thick) and 1/4 ton RSP (3.3 feet thick) both placed by Method B, see Figure A-5.

B. Loosely wrap perforated weep pipes with 2 sheets of newspaper to keep concrete out (do not use waterproofed paper.) Place cap on end of pipe, no glue.

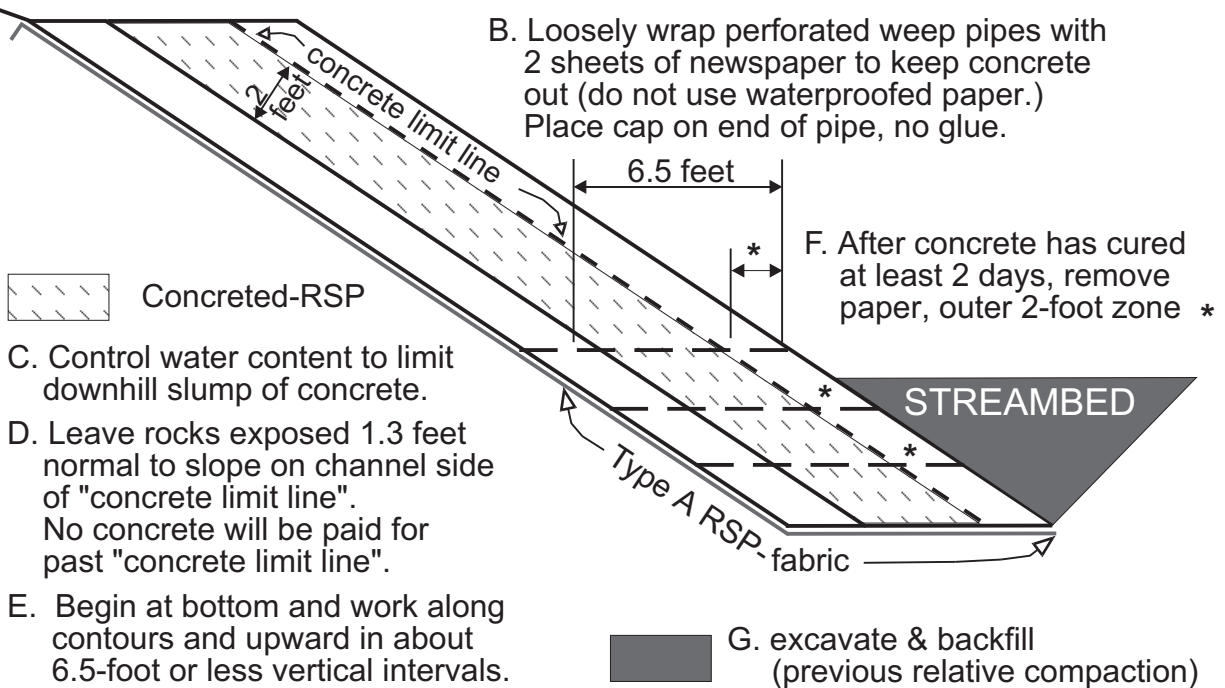

Figure A-7. CA Layered RSP with EMBEDDED Toe

Cross-section No Scale

DM is embedded depth below riverbed, and is a minimum of 1.5 meters, 2 x TOTAL thickness, to bedrock, or to scour elevation.

Elevation limit of RSP is site specific and may be higher than design high water.

If fill is placed along width of RSP bench, then place additional RSP-fabric as separator.

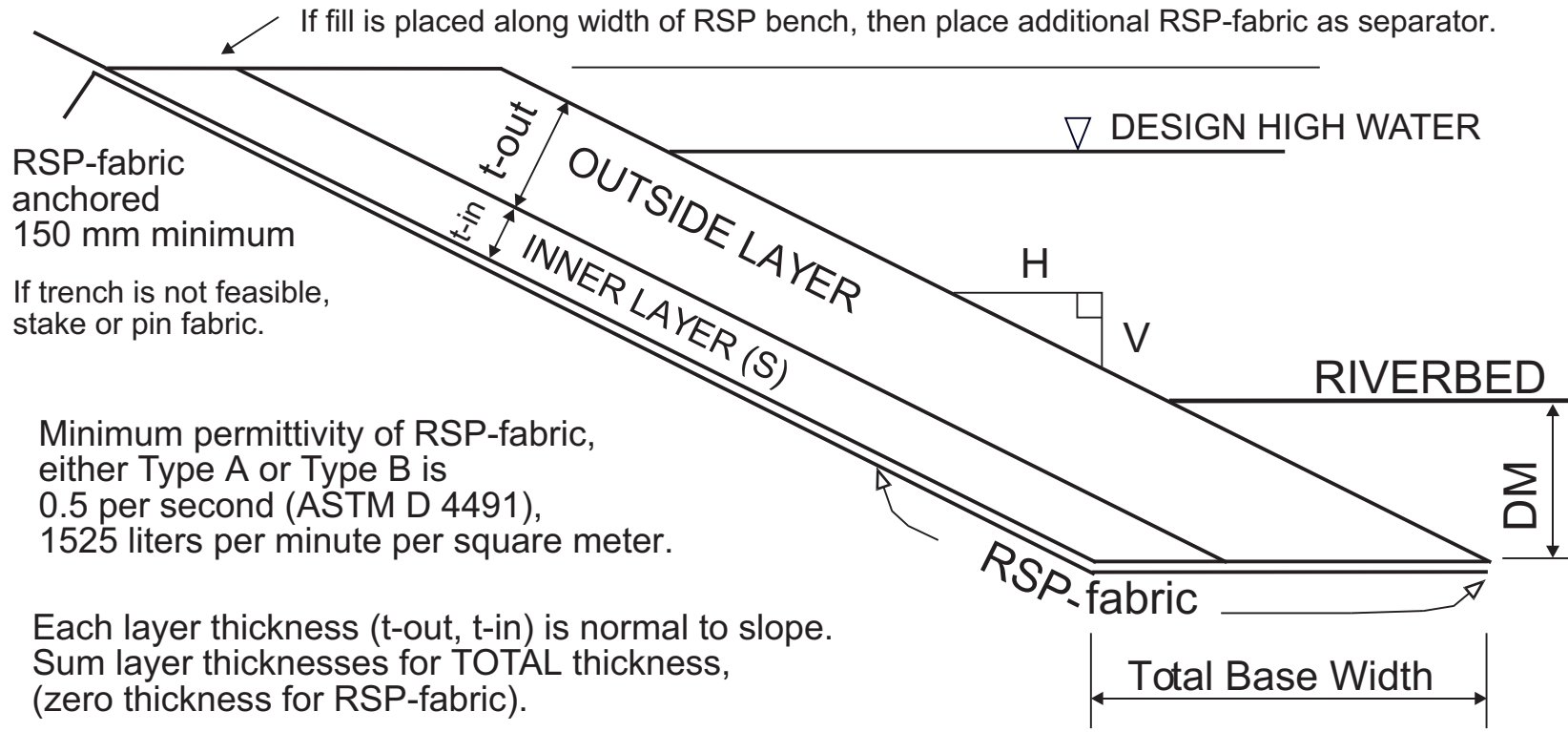

$$\text{Total Base Width} = \frac{\text{TOTAL thickness of RSP}}{\sin (\text{arc tan} (V/H))}$$

Figure A-8. CA Layered RSP with MOUNDED Toe

Cross-section No Scale

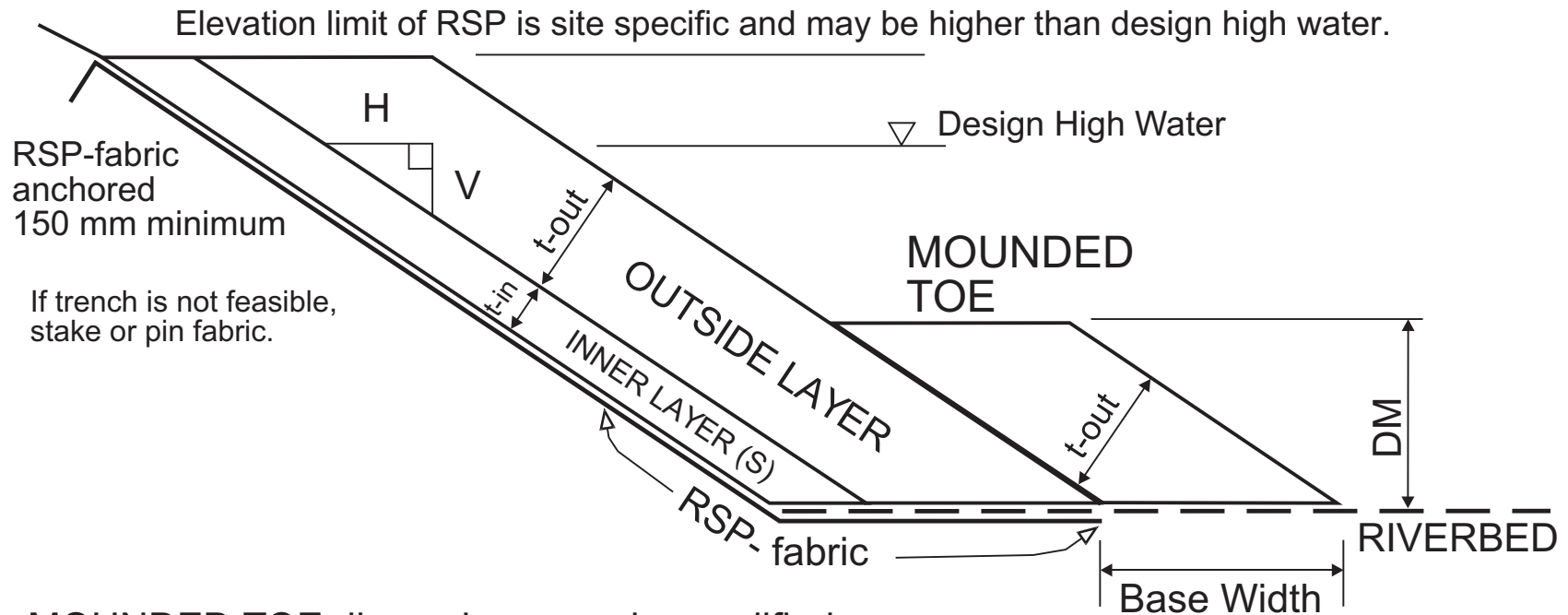

MOUNDED TOE dimensions may be modified :

1. Initial Height = EMBEDDED Depth, DM
2. Initial Base Width = $\frac{t\text{-out}}{\sin(\arctan(V/H))}$
3. Initial MOUNDED area = Initial Base Width x DM
4. Select trial Base Width
5. trial Height = Initial MOUNDED area / trial Base Width

Figure A- 9. CONCRETED-RSP Design Notes and Construction Details.

Cross-section No Scale

Construct rock revetment by Method A or B as specified, then place concrete.

A. Concreted-RSP has an EMBEDDED Toe of depth DM. Other standard components are RSP-fabric, inner and outside layers, similar to CA Layered RSP.

B. Install weep pipes or omit concrete at rock voids in the OUTSIDE layer for seepage. Each weep must have an open (random) path to the RSP-fabric.

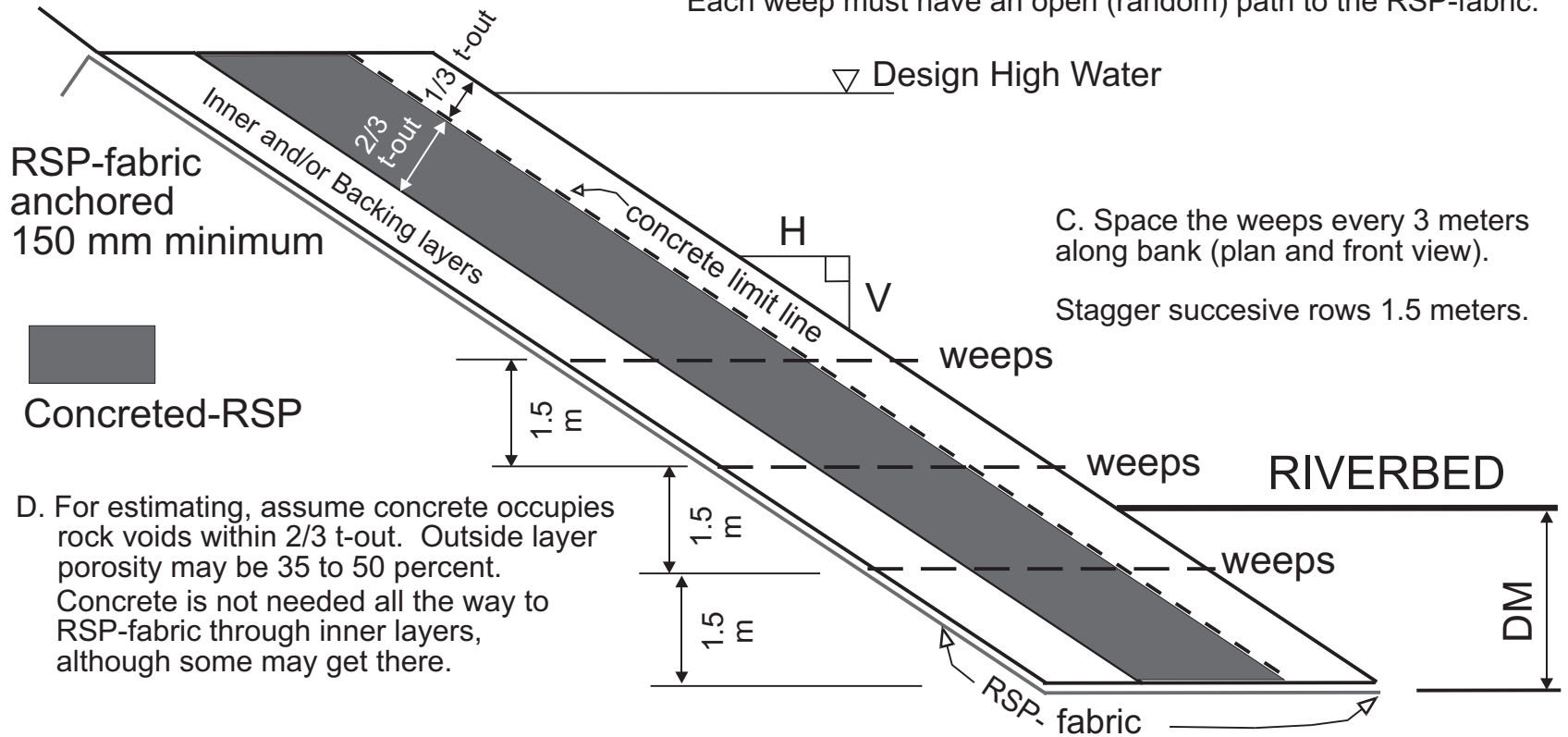

C. Space the weeps every 3 meters along bank (plan and front view).
Stagger successive rows 1.5 meters.

D. For estimating, assume concrete occupies rock voids within 2/3 t-out. Outside layer porosity may be 35 to 50 percent. Concrete is not needed all the way to RSP-fabric through inner layers, although some may get there.

E. Control water content, limit concrete placement to 2 meters or less (elevation) to prevent oozing beyond concrete limit line. Cold joints are acceptable. Place concrete from low to high elevation, ideally with pump and boom-mounted hose. Let individual rocks protrude beyond concrete limit line about 1/3 t-out, (1/3 OUTSIDE layer thickness).

Appendix B. Excerpts of Caltrans Specifications

SECTION 72 SLOPE PROTECTION

72-1 GENERAL

72-1.01 Description.—Slope protection consists of rock, concrete, concreted-rock or slope paving. The type of slope protection to be used will be designated in the Engineer's Estimate, the special provisions or shown on the plans. The slope protection shall be placed in conformance with these specifications, the special provisions, and the details and dimensions shown on the plans or directed by the Engineer.

72-2 ROCK SLOPE PROTECTION

72-2.01 Description.—This work shall consist of placing revetment type rock courses on the slopes.

The mass of the individual pieces of rock in each class shall be as indicated in the table in Section 72-2.02, "Materials," or as specified in the special provisions. The classes of rock slope protection will be designated in the Engineer's Estimate as 8T, 4T, 2T, 1T, 1/2T, 1/4T, Light, Facing, and No. 1, No. 2 or No. 3 Backing.

72-2.02 Materials.—The individual classes of rocks used in rock slope protection shall conform to the following, unless otherwise specified in the special provisions, or as shown on the plans.

GRADING OF ROCK SLOPE PROTECTION

PERCENTAGE LARGER THAN*

<i>Rock Mass</i>	<i>Method A Placement</i>					<i>Method B Placement</i>								
	<i>Classes</i>					<i>Classes</i>								
												<i>Backing</i>		
	<i>8T</i>	<i>4T</i>	<i>2T</i>	<i>1T</i>	<i>1/2T</i>	<i>1T</i>	<i>1/2T</i>	<i>1/4T</i>	<i>Light</i>	<i>Facing</i>	<i>No. 1</i>	<i>No. 2</i>	<i>No. 3</i>	
14.5-Tonne	0-5	—	—	—	—	—	—	—	—	—	—	—	—	
7.25-Tonne	50-100	0-5	—	—	—	—	—	—	—	—	—	—	—	
3.6-Tonne	95-100	50-100	0-5	—	—	—	—	—	—	—	—	—	—	
1.8-Tonne	—	95-100	50-100	0-5	—	0-5	—	—	—	—	—	—	—	
900-kg	—	—	95-100	50-100	0-5	50-100	0-5	—	—	—	—	—	—	
450-kg	—	—	—	95-100	50-100	—	50-100	0-5	—	—	—	—	—	
220-kg	—	—	—	—	95-100	95-100	—	50-100	0-5	—	—	—	—	
90-kg	—	—	—	—	—	—	95-100	—	50-100	0-5	0-5	—	—	
34-kg	—	—	—	—	—	—	—	95-100	—	50-100	50-100	0-5	—	
11-kg	—	—	—	—	—	—	—	—	95-100	90-100	90-100	25-75	0-5	
2.2-kg	—	—	—	—	—	—	—	—	—	—	—	90-100	25-75	
0.4-kg	—	—	—	—	—	—	—	—	—	—	—	—	90-100	

* The amount of material smaller than the smallest rock mass listed in the table for any class of rock slope protection shall not exceed the percentage limit listed in the table determined on a mass basis. Compliance with the percentage limit shown in the table for all other rock masses of the individual pieces of any class of rock slope protection shall be determined by the ratio of the number of individual pieces larger than the specified rock mass compared to the total number of individual pieces larger than the smallest rock mass listed in the table for that class.

The material shall also conform to the following quality requirements:

<i>Test</i>	<i>California Test</i>	<i>Requirement</i>
Apparent Specific Gravity	206	2.5 min.
Absorption	206	4.2% max.*
Durability Index	229	52 min.*

$$\frac{\text{Coarse Durability Index}}{\% \text{ Absorption} + 1} = \text{Durability Absorption Ratio (DAR)}$$

* Based on the formula contained herein, absorption may exceed 4.2 percent if DAR is greater than 10. Durability Index may be less than 52 if DAR is greater than 24.

Rocks, when conforming to the provisions in this Section 72-2.02, may be obtained from rock excavation of the roadway prism or other excavation being performed under the provisions of the contract, in accordance with the provisions in Section 4-1.05, "Use of Materials Found on the Work."

Rocks shall be of such shape as to form a stable protection structure of the required section. Rounded boulders or cobbles shall not be used on prepared ground surfaces having slopes steeper than 1:2 (vertical:horizontal). Angular shapes may be used on any planned slope. Flat or needle shapes will not be accepted unless the thickness of the individual pieces is greater than 0.33 times the length.

72-2.025 Rock Slope Protection Fabric.—Rock slope protection fabric shall be placed prior to placing rock slope protection, when the fabric is shown on the plans, or specified in the special provisions, or ordered by the Engineer.

Rock slope protection fabric shall conform to the provisions in Section 88, "Engineering Fabrics," and shall be placed in accordance with the details shown on the plans and as specified in these specifications.

Prior to placing rock slope protection fabric, the surfaces upon or against which rock slope protection fabric is to be placed, shall be free of loose or extraneous material and sharp objects that may damage the fabric during installation.

Rock slope protection fabric shall be handled and placed in accordance with the manufacturer's recommendations and as directed by the Engineer. Rock slope protection fabric shall be placed loosely upon or against the surface to receive the fabric so that the fabric conforms to the surface without damage when the cover material is placed.

Rock slope protection fabrics shall be joined, at the option of the Contractor, either with overlapped joints or stitched seams.

When fabric is joined with overlapped joints all adjacent borders of the fabric shall be overlapped not less than 600 mm. The fabric shall be placed such that the fabric being placed shall overlap the adjacent section of fabric in the direction the cover material is being placed.

When the fabric is joined by stitched seams, the fabric shall be stitched with yarn of a contrasting color. The size and composition of the yarn shall be as recommended by the fabric manufacturer. The number of stitches per 25 mm of seam shall be approximately 5 to 7. The strength of stitched seams shall be the same as specified for the fabric, except when stitched seams are oriented up and down a slope the strength shall be a minimum of 80 percent of that specified for the fabric.

Equipment or vehicles shall not be operated or driven directly on the rock slope protection fabric.

Rock slope protection fabric damaged during placement shall be replaced or repaired, as directed by the Engineer, by the Contractor at the Contractor's expense. Fabric damaged beyond repair, as determined by the Engineer, shall be replaced. Repairing damaged fabric shall consist of placing new fabric over the damaged area. The minimum fabric overlap from the edge of the damaged area shall be one meter for overlap joints. If the new fabric joints at the damaged areas are joined by stitching, the stitched joints shall conform to the requirements specified herein.

72-2.03 Placing.—Rock slope protection shall be placed in accordance with one of the following methods as designated in the Engineer's Estimate.

Method A Placement

A footing trench shall be excavated along the toe of slope as shown on the plans.

The larger rocks shall be placed in the footing trench.

Rocks shall be placed with their longitudinal axis normal to the embankment face and arranged so that each rock above the foundation course has a 3-point bearing on the underlying rocks. Foundation course is the course placed on the slope in contact with the ground surface. Bearing on smaller rocks which may be used for chinking voids will not be acceptable. Placing of rocks by dumping will not be permitted.

Local surface irregularities of the slope protection shall not vary from the planned slope by more than 0.3-m measured at right angles to the slope.

Method B Placement

A footing trench shall be excavated along the toe of the slope as shown on the plans.

Rocks shall be so placed as to provide a minimum of voids and the larger rocks shall be placed in the toe course and on the outside surface of the slope protection. The rock may be placed by dumping and may be spread in layers by bulldozers or other suitable equipment.

Local surface irregularities of the slope protection shall not vary from the planned slopes by more than 0.3-m measured at right angles to the slope.

At the completion of slope protection work, the footing trench shall be filled with excavated material and compaction will not be required.

72-2.04 Measurement.—Rock slope protection will be measured by the tonne or cubic meter as designated in the Engineer's Estimate.

Quantities of rock slope protection to be paid for by the cubic meter will be determined from the dimensions shown on the plans or the dimensions directed by the Engineer and rock slope protection placed in excess of these dimensions will not be paid for.

Quantities of rock slope protection to be paid for by the tonne will be weighed in accordance with the provisions in Section 9-1.01, "Measurement of Quantities."

Rock slope protection fabric will be measured by the square meter. The quantity to be paid for will be the actual area covered not including additional fabric required for overlaps.

72-2.05 Payment.—The contract price paid per cubic meter or per tonne for rock slope protection (the class of rock and method of placement to be designated in the Engineer's Estimate) shall include full compensation for furnishing all labor, materials, tools, equipment, and incidentals, and for doing all the work involved in constructing the rock slope protection, complete in place, including excavation, and backfilling footing trenches, as shown on the plans, and as specified in these specifications and the special provisions, and as directed by the Engineer.

The contract price paid per square meter for rock slope protection fabric shall include full compensation for furnishing all labor, materials, tools, equipment, and incidentals, and for doing all the work involved in furnishing and placing rock slope protection fabric, complete in place, as shown on the plans, as specified in these specifications and the special provisions, and as directed by the Engineer.

72-5 CONCRETED-ROCK SLOPE PROTECTION

72-5.01 Description.—This work shall consist of placing revetment

type concreted-rock courses on the slopes.

The rock slope protection shall be concreted as shown on the plans and as specified in these specifications and the special provisions.

The mass of the individual pieces of rock in each class shall be as indicated in the table in Section 72-5.02, "Materials," or as specified in the special provisions. The classes of concreted-rock slope protection will be designated in the Engineer's Estimate as 1/2T, 1/4T, Light, Facing, and Cobble.

72-5.02 Materials.—The individual classes of rocks used in concreted-rock slope protection shall conform to the following, unless otherwise specified in the special provisions or shown on the plans.

GRADING OF CONCRETED-ROCK SLOPE PROTECTION

Rock Mass	PERCENTAGE LARGER THAN*				
	Classes				
	1/2T	1/4T	Light	Facing	Cobble
900-kg	0-5	—	—	—	—
450-kg	50-100	0-5	—	—	—
220-kg	—	50-100	0-5	—	—
90-kg	90-100	—	50-100	0-5	—
34-kg	—	90-100	90-100	50-100	0-5
11-kg	—	—	—	90-100	95-100
Minimum Penetration of Concrete (millimeters)	450	350	250	200	150

* The amount of material smaller than the smallest rock mass listed in the table for any class of concreted-rock slope protection shall not exceed the percentage limit listed in the table determined on a mass bases. Compliance with the percentage limit shown in the table for all other rock masses of the individual pieces of any class of concreted-rock slope protection shall be determined by the ratio of the number of individual pieces larger than the specified rock mass compared to the total number of individual pieces larger than the smallest rock mass listed in the table for that class.

The rock shall also conform to the following quality requirements:

Tests	California	
	Test	Requirements
Apparent Specific Gravity	206	2.5 min.
Absorption	206	4.2% max.*
Durability Index.....	229	52 min.*

$$\frac{\text{Coarse Durability Index}}{\% \text{ Absorption} + 1} = \text{Durability Absorption Ratio (DAR)}$$

* Based on the formula contained herein, absorption may exceed 4.2 percent if DAR is greater than 10. Durability Index may be less than 52 if DAR is greater than 24.

Rocks, when conforming to the provisions in this Section 72-5.02, may be obtained from rock excavation of the roadway prism or other excavation being performed under the provisions of the contract, in accordance with the provisions in Section 4-1.05, "Use of Materials Found on the Work."

Rocks shall be of such shape as to form a stable protection structure of

the required section. Flat or needle shapes will not be accepted unless the thickness of the individual pieces is greater than 0.33-times the length.

Concrete shall be Class 3 concrete or minor concrete conforming to the provisions in Section 90, "Portland Cement Concrete," using 25-mm combined aggregate and mixed as provided for structures. The water content of the concrete shall be such as to permit gravity flow into the interstices with limited spading and brooming. The amount of water used shall be that designated by the Engineer.

72-5.03 Placing Rock.—Rock for concreted-rock slope protection shall be placed in accordance with one of the following methods as designated in the Engineer's Estimate.

Method A Placement

A footing trench shall be excavated along the toe of slope as shown on the plans.

The larger rocks shall be placed in the footing trench.

Rocks shall be placed with their longitudinal axis normal to the embankment face and arranged so that each rock above the foundation course has a 3-point bearing on the underlying rocks. Foundation course is the course placed on the slope in contact with the ground surface. Bearing on smaller rocks which may be used for chinking voids will not be acceptable. Placing of rocks by dumping will not be permitted.

Local surface irregularities of the slope protection shall not vary from the planned slope by more than 0.3-m measured at right angles to the slope.

Method B Placement

A footing trench shall be excavated along the toe of the slope as shown on the plans.

Rocks shall be so placed as to provide a minimum of voids and the larger rocks shall be placed in the toe course and on the outside surface of the slope protection. The rock may be placed by dumping and may be spread in layers by bulldozers or other suitable equipment.

Local surface irregularities of the slope protection shall not vary from the planned slopes by more than 0.3-m measured at right angles to the slope.

At the completion of slope protection work, the footing trench shall be filled with excavated material and compaction will not be required.

72-5.04 Placing Concrete.—The surfaces of the rock to be concreted shall be cleaned of adhering dirt and clay and then moistened. The concrete shall be placed in a continuous operation for any day's run at any one location. Concrete shall be brought to the place of final deposit by use of chutes, tubes, or buckets, or may be placed by means of pneumatic equipment or other mechanical methods. In no case shall concrete be permitted to flow on the slope protection a distance in excess of 3 m.

Immediately after depositing, the concrete shall be spaded and rodded into place with suitable spades, trowels or other approved means until the minimum penetration is that shown in the table entitled "Grading of

Concreted-Rock Slope Protection" in Section 72-5.02, "Materials."

After the concrete has been placed, the rocks shall be thoroughly brushed so that their top surfaces are exposed. The outer rocks shall project 0.33 to 0.25 times their diameter above the concrete surface. After completion of any 3-m strip, no workman or load shall be permitted on the surface for a period of at least 24 hours, and longer if so ordered by the Engineer.

Concreted-rock slope protection shall be cured as provided in Section 90-7, "Curing Concrete."

72-5.05 Measurement.—Concreted-rock slope protection will be measured by the tonne or cubic meter for the rock as designated in the Engineer's Estimate and by the cubic meter for the concrete.

Quantities of rock to be paid for by the cubic meter will be determined from the dimensions shown on the plans or the dimensions directed by the Engineer and rock placed in excess of these dimensions will not be paid for.

Quantities of rock to be paid for by the tonne will be weighed in accordance with the provisions in Section 9-1.01, "Measurement of Quantities."

Quantities of concrete to be paid for by the cubic meter will be measured at the mixer as provided in Section 90-11, "Measurement and Payment."

72-5.06 Payment.—The contract price paid per cubic meter or per tonne for concreted-rock slope protection (the class of rock and method of placement to be designated in the Engineer's Estimate) and per cubic meter for concrete (concreted-rock slope protection) shall include full compensation for furnishing all labor, materials, tools, equipment, and incidentals, and for doing all the work involved in constructing the concreted-rock slope protection, complete in place, including excavation, and backfilling footing trenches, as shown on the plans, and as specified in these specifications and the special provisions, and as directed by the Engineer.

88-1.04 Rock Slope Protection Fabric.—Rock slope protection fabric shall be manufactured from polyester, nylon, polypropylene or polyvinylidene material or any combination thereof.

Rock slope protection fabric shall be treated with ultraviolet ray (UV) protection. The UV treated fabric shall provide a minimum of 70 percent breaking strength retention after 500 hours exposure when tested in accordance with ASTM Designation: D 4355. Unless otherwise specified, the Contractor shall submit samples of the treated fabric to the Transportation Laboratory at least 45 days prior to use.

Rock slope protection fabric shall be, at the option of the Contractor, either woven filament or nonwoven type fabric.

Woven filament type rock slope protection fabric shall be Type A or Type B as specified in the special provisions. The woven filament fabric shall be manufactured from individually extruded and quenched filaments, not from larger previously quenched fibers or films, and shall conform to the following:

<i>Specification</i>	<i>Requirement</i>	
	<i>Type A</i>	<i>Type B</i>
Weight, grams per square meter, min., ASTM Designation: D 3776	135	200
Grab tensile strength (25-mm grip), kilonewtons, min. in each direction, ASTM Designation: D 4632.....	0.45	0.89
Elongation at break, percent max., ASTM Designation: D 4632	35	35
Toughness, kilonewtons, min. (Percent elongation x grab tensile strength)	15	31

All edges of woven filament fabric shall be either selvaged or serged.

Nonwoven type rock slope protection fabric shall be Type A or Type B as specified in the special provisions and shall conform to the following:

<i>Specification</i>	<i>Requirement</i>	
	<i>Type A</i>	<i>Type B</i>
Weight, grams per square meter, min., ASTM Designation: D 3776	135	200
Grab tensile strength (25-mm grip), kilonewtons, min. in each direction, ASTM Designation: D 4632.....	0.40	0.89
Elongation at break, percent min., ASTM Designation: D 4632	50	50
Toughness, kilonewtons, min. (Percent elongation x grab tensile strength)	26	53

88-1.05 Measurement and Payment.—Engineering fabrics will be measured and paid for in accordance with the provisions specified in the various sections of these specifications requiring the use of an engineering fabric or as specified in the special provisions.

.c2.10-1. SLOPE PROTECTION;--Slope protection shall conform to the provisions in Section 72, "Slope Protection," of the Standard Specifications.

(Use when required in projects with engineering fabric.)

.c2.8-1. ENGINEERING FABRICS;--Engineering fabrics shall conform to the requirements in Section 88, "Engineering Fabrics," of the Standard Specifications and these special provisions.

2

(Para. 2: Use when required by use of filter fabric on structure work, or when staged construction may require filter fabric to be exposed for more than 72 hours.)

All filter fabric for this project shall be ultraviolet ray (UV) protected.

3

(Paras. 3: Use when filter fabric or rock slope protection fabric are required AND there are less than 60 working days for the project.)

The requirement that UV treated fabrics be submitted to the Transportation Laboratory at least 45 days prior to use shall not apply.

Modified 6 DEC 1995 by James A. Racin, P.E. Caltrans Engineering Service Center 916-227-7017

(Add to SSP 72.01 when Rock Slope Protection Fabric is specified. Do NOT use the nomenclature or contract item "Filter Fabric (Rock Slope Protection)".)
(Use item code 729010 ROCK SLOPE PROTECTION FABRIC)
Include a contract item for Backing and other INNER layer RSP-classes when 1/4 T or larger RSP-class is specified as the OUTSIDE layer in the cross-section.)
(Include SSP Mtls-M81 when less than 60 Working Days are in the project.)

(Paragraphs 1 through 4: Use ONLY one paragraph.)

Rock slope protection fabric shall be WOVEN or NONWOVEN, Type A or Type B, at the option of the Contractor. 1

(Para. 2: Use when any RSP-class in the cross-section is larger than 1/4 T RSP-class.)

Rock slope protection fabric shall be WOVEN or NONWOVEN, Type B. 2

(Para. 3: Use when either WOVEN or NONWOVEN RSP-fabric is required by the Project Engineer, and insert only ONE, either "WOVEN" or "NONWOVEN".)

Rock slope protection fabric shall be _____ Type A or Type B, at the option of the contractor. 3

(Para. 4: Use when either WOVEN or NONWOVEN is required by the Project Engineer and any RSP in the cross-section is larger than 1/4 T RSP-class. Insert only ONE, either "WOVEN" or "NONWOVEN")

Rock slope protection fabric shall be _____ type fabric, Type B. 4

Addendum to SSP 72.15 Minimum Permittivity of RSP-fabric
to: Office Engineers and Project Engineers **6 December 1995**
Append to SSP 72.15 for all projects that specify RSP-fabrics.

Rock Slope Protection fabrics, both nonwoven and woven shall conform to section 88-1.04 of the Standard Specifications and shall meet the following additional requirement:

	Type A	Type B
Permittivity, 1/second, MINIMUM		
ASTM Designation: D 4491	0.5	0.5

to: Office Engineer and Project Engineers

On plans RSP-fabric has frequently been mis-labeled as "filter-fabric." Correct typical cross-section sheets to show RSP-fabric when it is the required material.