

United States  
Department of  
Agriculture

Forest Service

Technology &  
Development  
Program

7700—Transportation System  
2500—Watershed and Air  
Management  
October 1997  
9777 1812—SDTDC



# Relief Culverts

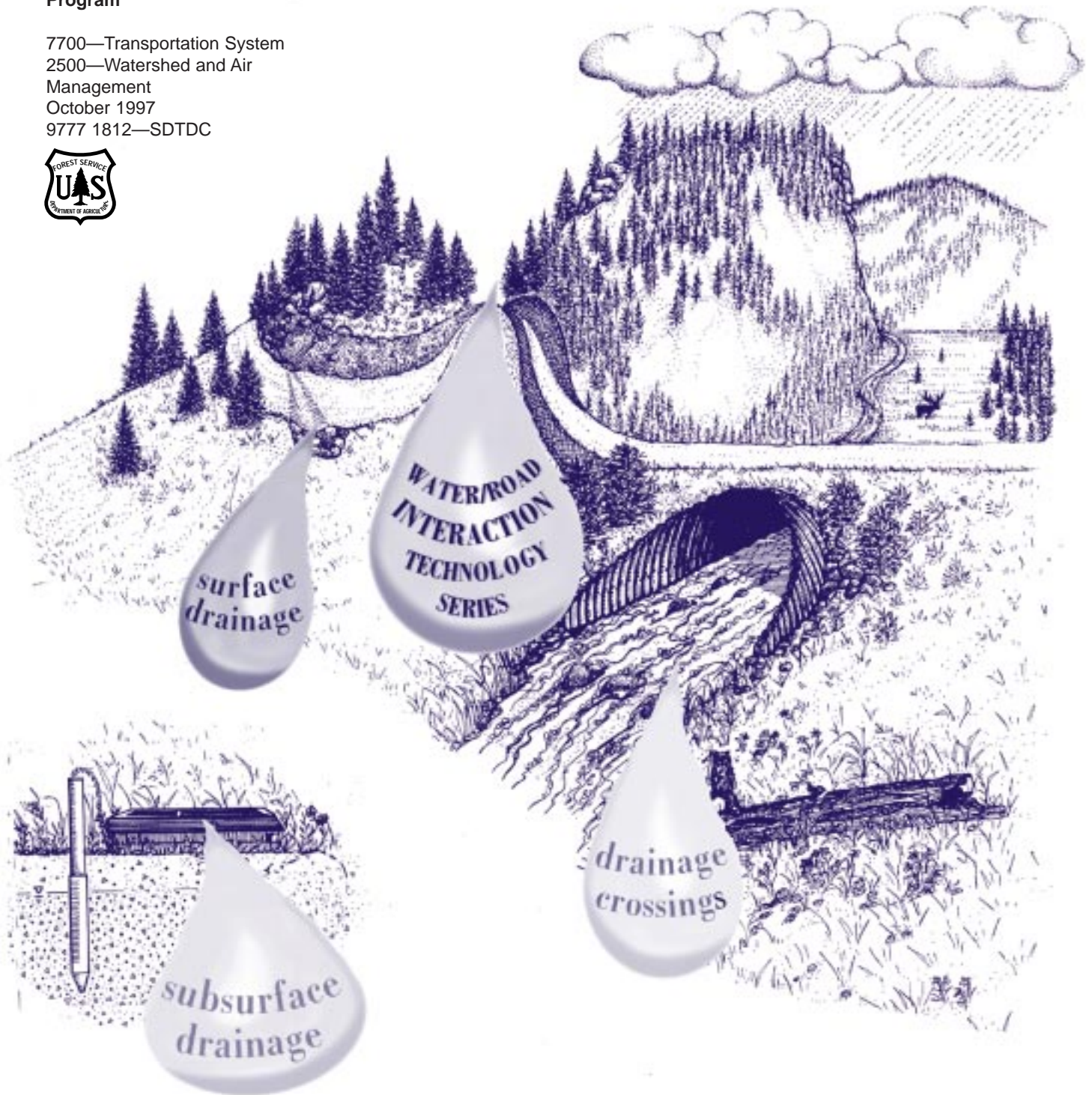

# Relief Culverts

**David Kim Johansen**

*Geotechnical Engineer, Willamette National Forest*

**Ronald Copstead, P.E.**

*Research Engineer, Pacific Northwest Research Station*

**Jeffry Moll, P.E.**

*Senior Project Leader, San Dimas Technology and Development Center*

**San Dimas Technology and Development Center  
San Dimas, California**

**October 1997**

---

Information contained in this document has been developed for the guidance of employees of the Forest Service, USDA, its contractors, and cooperating Federal and State agencies. The Department of Agriculture assumes no responsibility for the interpretation or use of this information by other than its own employees. The use of trade, firm, or corporation names is for the information and convenience of the reader. Such use does not constitute an official evaluation, conclusion, recommendation, endorsement, or approval of any product or service to the exclusion of others that may be suitable.

The United States Department of Agriculture (USDA) prohibits discrimination in its programs on the basis of race, color, national origin, sex, religion, age, disability, political beliefs, and marital or familial status. (Not all prohibited bases apply to all programs.) Persons with disabilities who require alternative means for communication of program information (braille, large print, audiotape, etc.) should contact USDA's TARGET Center at 202-720-2600 (voice and TDD).

To file a complaint, write the Secretary of Agriculture, U.S. Department of Agriculture, Washington, DC 20250, or call 1-800-245-630 (voice) or 202-720-1127 (TDD). USDA is an equal opportunity employer.

## RELIEF CULVERTS

### WHAT ARE THEY?

Relief culverts are conduits buried beneath the road surface to relieve drainage in longitudinal ditches at the toe of back slopes. They are crucial to most insloped and crowned road drainage systems and are placed at frequent intervals such that ditch flow does not concentrate to unmanageable levels. Relief culverts may be constructed from a variety of materials and may be circular, pipe arch, or rectangular in cross section (figure 1). Circular corrugated metal pipe are the most commonly used. Ditch relief culverts have a variety of inlet and outlet treatments to direct flows, prevent erosion, and avoid plugging.

For low flows on flat grades the designer may want to consider the use of surface cross drains and an outsloped template rather than ditches with relief culverts (Hausman and Pruett 1973, Packer and Christensen 1964, and Swift 1985).

### WHEN AND WHERE TO USE THEM

Relief culverts are used to:

1. Provide periodic drainage of roadside ditches that collect traveled way surface, back slope, and intercepted subsurface drainage.

2. Transport drainage that collects in a low point on one side of a fill to the other side.
3. Provide drainage and reduce maintenance in highly erodible or ruttable soils not conducive to reliable surface cross drain function. The outlet must be protected from erosion.

Relief culverts are more reliable than surface cross drains at the following locations:

1. On steep road grades, unless the surface cross drains are hardened or reinforced.
2. At the low point of sag vertical curves or dips, especially if wet.
3. At cut/fill transitions, as the pipe prevents erosion along the fill/natural ground contact and saturated fill problems.
4. On roads with a desired life of more than 20 years. Less frequent maintenance and fewer reconstructions are needed, and less vehicular damage and a better ride result.

Structural integrity of relief culverts is not affected by traffic when properly installed with adequate soil cover according to the manufacturer's recommendations. Such culvert installations also have no detrimental effect on traffic. Relief culverts are typically more economical than surface cross drains where

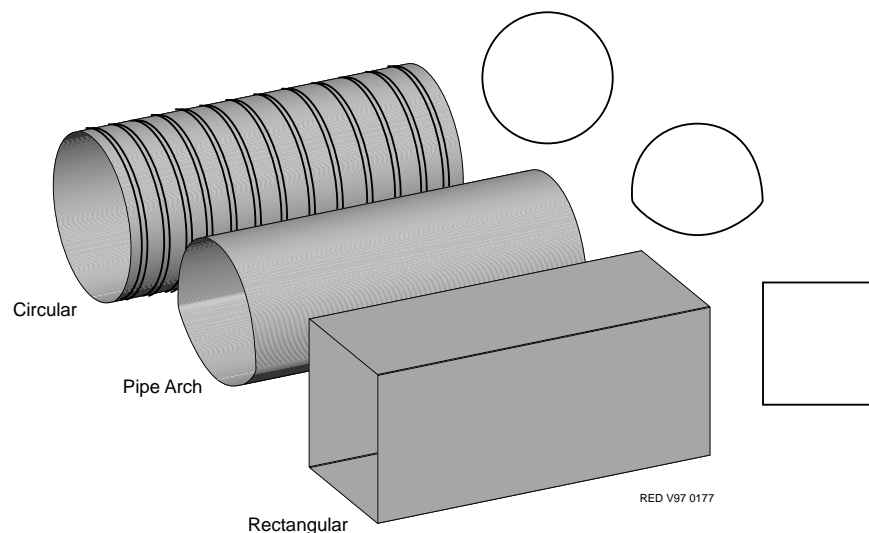

Figure 1—Common ditch relief culvert shapes.

traffic levels exceed ten to fifteen vehicles per day because of lower maintenance costs (Eck and Morgan 1987). The relative performance comparison between surface cross drains and culverts is summarized in table 1 for low volume roads. Table 2 compares advantages of culverts to advantages of surface cross drains. Sediment, gravel, cobbles, and boulders cause abrasion of culvert materials or coatings at different rates. Figure 2 shows the relative resistance of typical culvert materials to abrasion.

## DESIGN CONSIDERATIONS

### Location

Key factors in the successful use of culverts include proper spacing and location. The main objective of design is to determine the proper locations and sizes of relief culverts for the ditch; modifying spacing to account for landscape features may be necessary. When selecting sizes of culverts, it is important to consider debris potential and bedload passage in addition to requirements based on hydraulics and accepted hydrologic flow design. In areas with new roads and land development, drainage

patterns and runoff rates will change with time. Land clearing or timber harvest will generally increase runoff; subsequent vegetation reestablishment will lower it. Planning to adjust or add some relief culverts may be necessary to provide adequate drainage and erosion prevention. Relief culverts should be placed at the same spacing as surface cross drains in order to limit ditch erosion. Many spacing guides used in the Forest Service are based on measurements of the distance to develop a one-inch rill in the surface for different grades and soil conditions (Packer 1967). This same criteria can be used to limit rill erosion in roadside ditches for moderate flows. Taking the above into consideration, the recommended maximum relief culvert spacing based on the Unified Soil Classification System (ASTM 1975) soil types and road gradient is shown in table 3. If ditch lining materials are used, relief culvert spacing can be increased and should be based on hydraulic calculations. Local observations of soil or geologic type may be useful in designing an adequate spacing.

Table 1—Comparison of cross drain type for low volume roads.

Type	Ride	Erosion	Sedimentation	Debris handling
Surface cross drains	Poor to fair	Road surface, in cross drain, at outlet	Tend to fill in	May affect performance, but still functions
Relief culverts	No effect	Road surface, in ditch, at outlet	Inlets plug	Needs periodic maintenance and inspection to avoid plugging

Table 2—Comparison of advantages of culverts to advantages of surface cross drains.

Culverts	Surface cross drains
Reliable	Easily repaired
Reduced road surface erosion, no dip to soften and rut	No inlet to plug, no fill to wash out, no need to remove during road closure
Excellent ride	No pipe to corrode or abrade
Less maintenance, suitable for steeper grades. More economical for higher traffic roads	Motor grader maintains during surface blading operation Lower installation cost
Variety of materials available for different situations	Crafted of onsite material or imported aggregate

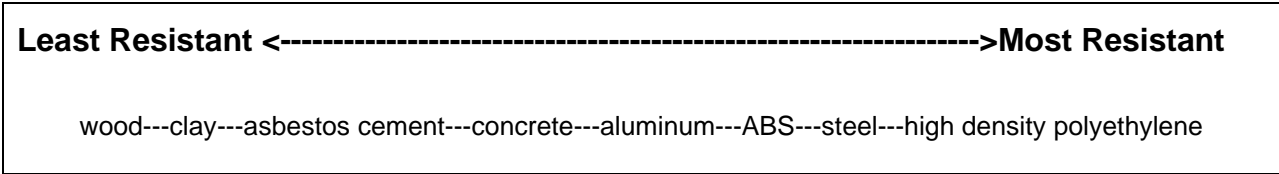

Figure 2—Relative abrasion resistance of some relief culvert materials (Normann et al. 1985).

Table 3—Guidelines for maximum relief culvert spacing in meters, based on ditch soil type.

Road Grade percent	Group 1 GW, GP, Aggregate Surfacing	Group 2 GM GC	Group 3 CH, CL	Group 4 MH, SC, SM	Groups 5&6 SW, SP, ML
	----- meters -----				
2	120	97	75	52	29
4	103	84	65	45	26
6	88	71	55	39	23
8	74	60	47	33	20
10	61	50	39	28	17
12	50	41	32	23	14
14	42	34	26	19	11

The above guidelines should be adjusted according to the following (Packer and Christenson 1964):

1. Reduce the spacing by 5 m if the road is located in the middle one-third of a slope.
2. Reduce the spacing by 11 m if the road is located in the bottom one-third of a slope.
3. Reduce the spacing by 3 m if the road is on an east or west exposure.
4. Reduce the spacing by 6 m if the road is on a south slope.
5. If the resulting spacing after items 1–4 falls below 17 m, use relief culverts at 17-m spacing and apply aggregate surfacing and erosion protection measures such as vegetative seeding to ditches, road surface, fills, shoulders, and embankments.

Surface relief culverts should be located:

- Far enough above stream crossings to provide buffering and to avoid releasing ditch drainage water directly into streams
- Whenever possible to release water on convex slopes or other stable and non-erosive areas that will absorb road drainage and retard sediment flows before reaching streams
- Above road segments with steeper downhill grade.

**Size**

Ditches and culverts can be sized using standard hydrologic and hydraulic formulas for specific sites. Design the ditch first, then use the design flow to choose a relief culvert with sufficient capacity to handle that flow. Adjust the size accordingly if debris or sediment plugging is anticipated. A commonly used size of relief culvert is 450 mm in diameter, while the minimum used should be 300 mm. Table 4 shows the range of capacities of four relief culvert diameters for various materials.

Table 4—Flow capacity (m<sup>3</sup>/s) for inlet control relief culverts for headwater to diameter ratio of 1.0 to 1.5, grades 0.5 percent to 10 percent (GKY and Associates 1992).

Culvert Material	N value	Diameter			
		300 mm	450 mm	600 mm	750 mm
PVC	0.009	0.16-0.24	0.43-0.64	0.85-1.33	1.52-2.27
Steel pipe	0.001	0.14-0.22	0.38-0.58	0.77-1.20	1.37-2.04
Concrete, clay, spiral ribbed metal, or smooth lined metal	0.013	0.11-0.17	0.30-0.44	0.59-0.92	1.05-1.57
Wood	0.016	0.09-0.14	0.24-0.36	0.48-0.75	0.86-1.28
Corrugated plastic tubing	0.020	0.07-0.11	0.19-0.29	0.38-0.60	0.68-1.02
Corrugated steel or aluminum, 2-2/3 × 1/2 corrugations	0.024	0.06-0.09	0.16-0.24	0.32-0.50	0.57-0.85

Lowest values correspond to 0.5 percent grade and headwater to culvert diameter ratio of 1.0; highest values correspond to 10 percent grade and headwater height to diameter ratio of 1.5.

Example: Required corrugated steel pipe capacity = 0.12 m<sup>3</sup>/s, (cubic meters per second)

Given:

$$HW/D = 1.0$$

$$\text{Grade} = 2 \text{ percent}$$

Use 450 mm corrugated metal pipe culvert diameter.

Smaller culverts may be used but will need closer spacing and will tend to plug more easily. Larger diameter pipes can be used as relief culverts to accommodate larger flows of water or to help prevent plugging of inlets in high erosion or woody debris problem areas. Multiple small pipes can be used in place of a bigger pipe to achieve the same flow capacity in sites with limited installation depth, but small pipes plug easier than one large pipe.

Culvert material, corrugation, diameter, and thickness should be based on the minimum cover desired and the hydraulic capacity needed. Spacing guidelines are based on ditch erosion, but sites with high rainfall and large drainage areas contributing to a segment of ditch should be checked using hydraulic calculations.

## MATERIALS

Corrosion is the deterioration of culvert materials by chemical or electrochemical reactions to the environment. It is generally related to water and chemicals that have reacted to, become dissolved in, or been transported by water. Both the inside and outside of the culvert barrel can be attacked. Corrosion can occur in metal or concrete pipe that has become cracked, spalled, or is porous enough to allow water to contact reinforcing steel. Surrounding the culvert with granular backfill will decrease the risk of corrosion. Where soil or water pH is less than 5.5 or greater than 8.5, corrosion potential is high. Steel and aluminum culverts can be protected from corrosion with bituminous fiber-bonded or mill applied thermoplastic coatings.

Abrasion is the process of wearing down or grinding away the surface material of culverts by water laden with sand, gravel, or cobbles. The higher the velocity of water flowing through the culvert, the greater the abrasion potential.

Corrosion resistant materials can be used to extend the life of a culvert installation. Tables 5, 6, and 7 give materials recommendations for various environmental/corrosion conditions.

Table 5—Acceptable conditions for resisting corrosion (ODOT 1990).

Material	Suitable Performance Conditions	Corrosion Service Life	UV Degradation
Reinforced or unreinforced concrete	pH: <sup>a</sup> > 4.5–10 R <sup>b</sup> >1500	75 years+	H <sup>c</sup>
Galvanized steel dry climate	pH 4.5–6, pH 6–7 pH 7–10 R 1500-2000 for all	30 35 40	H
Galvanized steel rainy climate	pH: 4.5–6, pH: 6–7 pH: 7–10 R 1500–2000 for all	15 20 25	H
Aluminum coated steel	pH: 5–9 R>1500	50 rainy 65 dry	H H
Aluminum	pH: 4.5–10, R>1500	75	H
Vitrified clay	N/A	Very durable	H
PVC	N/A	N/A	L
Polyethylene	pH: 4.5–10 R>1500	N/A	M

- a. pH = pH of water or soil surrounding pipe.
- b. R = resistivity, an electrical measurement in ohm-cm, which is one of the factors for estimating the corrosivity of a given soil to metals.
- c. H, M, and L are high, medium, and low resistivity, respectively.

Table 6—Increase in galvanized steel service life based on soil resistivity (ODOT 1990).

Resistivity	Multiply life by this factor
2,000 to < 3,000	1.2
3,000 to < 4,000	1.4
4,000 to < 5,000	1.6
5,000 to < 7,000	1.8
> 7,000	2

Table 7—Increased in metal pipe service life based on metal thickness (ODOT 1990).

Gage	Multiply life by this factor
16	1.0
14	1.3
12	1.7
10	2.2
8	2.9

The material type for a culvert should be based on:

1. Economy: construction, long-term maintenance, replacement cost.
2. Need for corrosion resistance where acidic soils exist.
3. Need for abrasion resistance where high sediment or bedload volumes are transported.
4. The thickness, corrugation type, or strength of culvert should be based on the amount of soil cover to be placed above the top of culvert and on expected traffic loads. Manufacturers recommendations should be followed in specifying thickness or corrugated type during installation.

Relief culverts may be made of a wide variety of materials. Beyond hydraulic requirements, factors to consider when choosing a culvert material include: local availability and cost; material resistance to abrasion, corrosion, and

ultraviolet deterioration; and construction factors. Culverts may be lined for increased corrosion or abrasion resistance.

Bituminous coating (AASHTO M190) metal pipe will add 10 years to the service life determined by the above tables in all locations.

### MAINTENANCE

Culvert inlets should be inspected frequently and maintained as required to prevent plugging. Protective measures can be taken to minimize inlet plugging. A backhoe or excavator is often needed for most installations. Hand work is often necessary to unplug culvert inlets of woody debris and boulders. Removing ice from culverts can be accomplished using a steam generating deicing unit (Bassel 1993).

### COST

Material and installation costs as of July 1997 are summarized in table 8.

Table 8—Material and installation costs, \$/meter of length.

Culvert Diameter	375 mm	450 mm	600 mm	750 mm
<b>Galvanized Steel or Aluminum</b>				
16 Gauge	\$20 to 26	\$52 to 66	\$62 to 79	\$72 to 92
14 Gauge	—	\$59 to 72	\$72 to 92	\$85 to 108
12 Gauge	—	—	\$89 to 12	\$108 to 135
<b>Bituminous Coated Steel</b>				
16 Gauge	\$23 to 30	\$59 to 72	\$72 to 92	\$89 to 112
14 Gauge	—	\$69 to 85	\$82 to 102	\$98 to 125
12 Gauge	—	—	\$98 to 125	\$121 to 151
<b>Corrugated Polyethylene (equivalent to 16 gauge steel in strength)</b>				
	\$16 to 23	\$49 to 62	\$75 to 95	—



## LITERATURE CITED

ASTM. 1975. Standard Method for Classification of Soils for Engineering Purposes. ASTM D-2487-69(75). Annual book of standards. Philadelphia, PA: ASTM.

Bassel, James R. 1993. Culvert Steamer—The Deicing of Frozen Culverts, Roads Tech Tips, Technology and Development Program. USDA Forest Service. October. (PH: 909-599-1267).

Eck, Ronald W. and Perry J. Morgan. 1987. Culverts Versus Dips in the Appalachian Region: A Performance-Based Decision Making Guide. Transportation Research Record 1106.

GKY and Associates, INC. 1992. Hydrain - Integrated Drainage Design Computer System, Volume VI. HY8 - Culverts. Washington, D.C.; Federal Highway Administration. p 34.

Hausman, Richard F. and Emerson W. Pruet. 1973. Permanent Logging Roads For Better Woodlot Management. USDA Forest Service State and Private Forestry Northeastern Area.

Normann, Jerome M., Robert J. Houghtalen, and William J. Johnston. 1985. Hydraulic Design of Highway Culverts. Rep. No. FHWA-IP-85-15 HDS No. 5. McLean, VA: Federal Highway Administration. p 272.

ODOT. 1990. Hydraulics Manual. Salem, OR: Oregon Dept. of Transportation, Highway Division. Irregular pagination.

Packer, Paul E. and George F. Christensen. 1964. Guides for Controlling Sediment From Secondary Logging Roads. USDA Forest Service Intermountain Forest and Range Experiment Station and Northern Region.

Packer, Paul E. 1967. Criteria for Designing and Locating Logging Roads to Control Sediment. Forest Science. 13(1): 1-18.

Swift, Lloyd W. Jr. 1985. Forest Road Design to Minimize Erosion in the Southern Appalachians. Proceedings of Forestry and Water Quality: A Mid-South Symposium, Little Rock, AK, May 8-9.