

U.S. DEPARTMENT OF AGRICULTURE FOREST SERVICE TIMBER SALE CONTRACT (Applicable to Sales to be Measured before Felling)		Name of Purchaser	
National Forest Ottawa	Ranger District Ontonagon	Region Eastern	Contract Number
Sale Name Change Out PR		Award Date	Termination Date 09/30/2024

The parties to this contract are The United States of America, acting through the Forest Service, United States Department of Agriculture, hereinafter called Forest Service, and _____ hereinafter called Purchaser.

Forest Service having advertised a sale at which either (1) Purchaser, whose required bid deposit is now held by Forest Service as an initial deposit, was the successful bidder, or (2) no bids were received and Purchaser having subsequently offered at least the minimum advertised price and made an initial deposit in the same amount as the bid deposit specified in the sale advertisement; and the parties hereto desiring to record their agreement; now therefore,

Unless provided otherwise herein, Forest Service agrees to sell and permit Purchaser to cut and remove Included Timber and Purchaser agrees to purchase, cut, and remove Included Timber.

This contract consists of three Divisions: AT - Specific Conditions, BT - Standard Provisions, and CT - Special Provisions, together with Sale Area Map, Plans and specifications for developments (if any), and such attachments as may be provided for in Division CT. Specific Conditions are numbered and apply to the Part, Section, Subsection, or Item of the Standard Provisions, as indicated hereunder. Other conditions of this contract are stated in Division CT - Special Provisions.

IN WITNESS WHEREOF, the parties hereto have executed this contract as of the award date.

UNITED STATES OF AMERICA

Two Witnesses:^{1/}

(Name)

(Address)

(Name)

(Address)

By: _____
Contracting Officer

(Title)

By: _____
(Purchaser) ^{2/}

(Title)

(Business Address)

I, ^{3/} _____, certify that I am the _____
Secretary of the corporation named as Purchaser herein; that _____
who signed this contract on behalf of Purchaser, was then _____
of the corporation; that the contract was duly signed for and in behalf of the corporation by authority of its governing body, and is
within the scope of its corporate powers.

**CORPORATE
SEAL** ^{4/}

INSTRUCTIONS:

- 1/ The signatures and addresses of two witnesses are required if Purchaser is other than a corporation.
- 2/ If Purchaser is a co-partnership, the signatures should be: XYZ Company, by John Doe, a member of the firm. If Purchaser is a corporation, form of signature should be: XYZ Company, by John Doe, President (or other officer or agent) and the seal of the corporation must be impressed or indicated.
- 3/ The certificate must be completed if Purchaser is a corporation.
- 4/ If the corporation has no corporate seal that fact shall be stated, in which case a scroll or adhesive seal shall follow the corporate name.

EXAMPLE 1/

Subcontractor Certification
Regarding Debarment, Suspension, Ineligibility, and Voluntary Exclusion

Timber Sale Name: _____
National Forest: _____

The prospective subcontractor (participants in lower tier covered transactions) certifies, by submission of this proposal, that neither it nor its principals is presently debarred, suspended, proposed for debarment, declared ineligible, or voluntarily excluded from participation in this timber sale by any Federal department or agency.

Where the prospective subcontractor is unable to certify to any of the statements in this certification, such prospective subcontractor shall attach an explanation to this proposal.

Name of Subcontractor: _____
Business Address: _____

_____ Date _____ Signature

1/ It is the Purchaser's responsibility to have subcontractors complete this certification and to maintain a file of completed certifications. This certification does not need to be returned to the Forest Service, except at the written request of the Contracting Officer.

The following conditions apply to the indicated portions of Division BT - Standard Provisions issued June 2006.

AT1 - Location and Area, applicable to BT1.1

This Sale Area of 891 acres more or less is located in:

T49N R37W S 19,30 Houghton County; T49N R38W S 24,25,36 Ontonagon County

AT2 - Volume Estimate and Utilization Standards, applicable to BT2.1, BT2.2, BT2.4, and BT6.4

Species	Product	Estimated Quantity *	Unit of Measure	Minimum Specifications				
				Merchantable Tree		Piece Required to be Removed		
				Diameter Breast High (d.b.h.) (inches)	Number of Minimum Pieces per Tree	Length (feet)	Diameter Inside Bark at Small End (inches)	Net Scale in % of Gross Scale
Mixed Conifer	Sawtimber	36.00	CCF	9.0	1	8	7.6	40
Mixed Hardwood	Sawtimber	127.00	CCF	11.0	1	8	9.6	50
Sugar Maple	Sawtimber	198.00	CCF	11.0	1	8	9.6	50
Aspen	Pulpwood	2,834.00	CCF	5.0	1	8	4.0	70
Mixed Conifer	Pulpwood	143.00	CCF	5.0	1	8	4.0	70
Mixed Hardwood	Pulpwood	2,019.00	CCF	5.0	1	8	4.0	70
Total Quantity		5,357.00	CCF					

* Quantities not included here are described in BT2.4.

AT3- Timber Designations, applicable to BT2.3; acres are approximate:

	Number	Acres
Clearcutting Units (BT2.31)	_____	_____
Specified Road Clearing (BT2.32)	_____	_____
Overstory Removal Units (BT2.33)	_____	_____
Understory Removal Units (BT2.34)	_____	_____
Individual Trees (BT2.35)	_____	344
Incompletely Measured Payment Units (BT2.36)	_____	_____

AT4 - Timber Payment Rates, applicable to BT3.1 and BT4.0

AT4a - For Species and Products to be Paid for at Rates Escalated under BT3.2

Not Applicable

AT4b- For Species and Products to be Paid for at Flat Rates

Species	Product	Unit of Measure	Rates per Unit of Measure				Required Deposits Slash Disposal \$
			Base \$	Advertised \$	Bid Premium \$	Bid (Flat) \$	
Mixed Conifer	Sawtimber	CCF	1.00	1.00			.00
Mixed Hardwood	Sawtimber	CCF	7.88	8.49			.00
Sugar Maple	Sawtimber	CCF	25.31	27.48			.00
Aspen	Pulpwood	CCF	2.08	2.18			.00
Mixed Conifer	Pulpwood	CCF	1.00	1.00			.00
Mixed Hardwood	Pulpwood	CCF	1.00	1.00			.00

For purposes of convenience in collection and bookkeeping, Bid Rates stated in AT4 include payment of deposits for sale area betterment required pursuant to 16 USC 576b. Such deposits are not included as Required Deposits defined hereunder.

AT4c - Schedule of Payment Units

Payment Unit No.	Approx. Acres	Quantity of Species and Products to be Escalated under AT4a	Total Tentative Payment \$	Quantity of Species and Products to be Paid for at Flat Rates under AT4b	Total Flat Rate Payment \$	Total Required Deposits for Slash Disposal \$
001	45			Mixed Conifer Sawtimber 2.00 CCF		.00
				Mixed Hardwood Sawtimber 14.00 CCF		
				Sugar Maple Sawtimber 38.00 CCF		
				Aspen Pulpwood 83.00 CCF		
				Mixed Conifer Pulpwood 2.00 CCF		
				Mixed Hardwood Pulpwood 283.00 CCF		
					Total PU Quantity And Value	
002	46			Mixed Conifer Sawtimber 2.00 CCF		.00
				Mixed Hardwood Sawtimber 21.00 CCF		
				Sugar Maple Sawtimber 32.00 CCF		
				Aspen Pulpwood 77.00 CCF		
				Mixed Conifer Pulpwood 2.00 CCF		
				Mixed Hardwood Pulpwood 294.00 CCF		
					Total PU Quantity And Value	
003	24			Mixed Conifer Sawtimber 1.00 CCF		.00
				Mixed Hardwood Sawtimber 15.00 CCF		
				Sugar Maple Sawtimber 24.00 CCF		
				Aspen Pulpwood 49.00 CCF		
				Mixed Conifer Pulpwood 1.00 CCF		
				Mixed Hardwood Pulpwood 153.00 CCF		
					Total PU Quantity And Value	
004	24			Mixed Conifer Sawtimber 1.00 CCF		.00
				Mixed Hardwood Sawtimber 16.00 CCF		
				Sugar Maple Sawtimber 35.00 CCF		
				Aspen Pulpwood 10.00 CCF		
				Mixed Conifer Pulpwood 0.00 CCF		
				Mixed Hardwood Pulpwood 153.00 CCF		
					Total PU Quantity And Value	
005	31			Mixed Conifer Sawtimber 0.00 CCF		.00
				Mixed Hardwood Sawtimber 13.00 CCF		
				Sugar Maple Sawtimber 41.00 CCF		
				Aspen Pulpwood 65.00 CCF		
				Mixed Conifer Pulpwood 14.00 CCF		
				Mixed Hardwood Pulpwood 157.00 CCF		
					Total PU Quantity And Value	
006	5			Mixed Conifer Sawtimber 1.00 CCF		.00
				Mixed Hardwood Sawtimber 3.00 CCF		
				Sugar Maple Sawtimber 2.00 CCF		
				Aspen Pulpwood 113.00 CCF		
				Mixed Conifer Pulpwood 8.00 CCF		
				Mixed Hardwood Pulpwood 46.00 CCF		
					Total PU Quantity And Value	
007	34			Mixed Conifer Sawtimber 3.00 CCF		.00
				Mixed Hardwood Sawtimber 17.00 CCF		
				Sugar Maple Sawtimber 1.00 CCF		
				Aspen Pulpwood 535.00 CCF		
				Mixed Conifer Pulpwood 24.00 CCF		
				Mixed Hardwood Pulpwood 307.00 CCF		
					Total PU Quantity And Value	

Payment Unit No.	Approx. Acres	Quantity of Species and Products to be Escalated under AT4a	Total Tentative Payment \$	Quantity of Species and Products to be Paid for at Flat Rates under AT4b	Total Flat Rate Payment \$	Total Required Deposits for Slash Disposal \$
008	41			Mixed Conifer Sawtimber 3.00 CCF		
				Mixed Hardwood Sawtimber 1.00 CCF		
				Sugar Maple Sawtimber 3.00 CCF		
				Aspen Pulpwood 460.00 CCF		
				Mixed Conifer Pulpwood 33.00 CCF		
				Mixed Hardwood Pulpwood 140.00 CCF		
				Total PU Quantity And Value 640.00 CCF		
009	16			Mixed Conifer Sawtimber 5.00 CCF		
				Mixed Hardwood Sawtimber 4.00 CCF		
				Sugar Maple Sawtimber 1.00 CCF		
				Aspen Pulpwood 290.00 CCF		
				Mixed Conifer Pulpwood 11.00 CCF		
				Mixed Hardwood Pulpwood 99.00 CCF		
				Total PU Quantity And Value 410.00 CCF		
010	21			Mixed Conifer Sawtimber 4.00 CCF		
				Mixed Hardwood Sawtimber 1.00 CCF		
				Sugar Maple Sawtimber 0.00 CCF		
				Aspen Pulpwood 351.00 CCF		
				Mixed Conifer Pulpwood 15.00 CCF		
				Mixed Hardwood Pulpwood 54.00 CCF		
				Total PU Quantity And Value 425.00 CCF		
011	22			Mixed Conifer Sawtimber 6.00 CCF		
				Mixed Hardwood Sawtimber 7.00 CCF		
				Sugar Maple Sawtimber 14.00 CCF		
				Aspen Pulpwood 282.00 CCF		
				Mixed Conifer Pulpwood 6.00 CCF		
				Mixed Hardwood Pulpwood 76.00 CCF		
				Total PU Quantity And Value 391.00 CCF		
012	34			Mixed Conifer Sawtimber 8.00 CCF		
				Mixed Hardwood Sawtimber 8.00 CCF		
				Sugar Maple Sawtimber 4.00 CCF		
				Aspen Pulpwood 459.00 CCF		
				Mixed Conifer Pulpwood 15.00 CCF		
				Mixed Hardwood Pulpwood 208.00 CCF		
				Total PU Quantity And Value 702.00 CCF		
013	1			Mixed Conifer Sawtimber 0.00 CCF		
				Mixed Hardwood Sawtimber 7.00 CCF		
				Sugar Maple Sawtimber 3.00 CCF		
				Aspen Pulpwood 60.00 CCF		
				Mixed Conifer Pulpwood 12.00 CCF		
				Mixed Hardwood Pulpwood 49.00 CCF		
				Total PU Quantity And Value 131.00 CCF		

The following definitions are established for the terms used in AT4:

Base Rates are the lowest rates of payment for timber that are authorized by this contract. Base Rates remain constant throughout the life of this contract and are not subject to change by rate redetermination, except for reduction under BT3.31, BT3.32, or BT3.33.

Advertised Rates are the minimum acceptable Bid Rates for timber, exclusive of Required Deposits. These rates are those indicated by appraisal, with a cost allowance made for construction of Specified Roads listed in AT7, but are never less than Base Rates.

Bid Premium Rates are the amounts by which Purchaser's bid is in excess of Advertised Rates. The Bid Premium Rates are constant during this contract, except as provided in BT3.31, BT3.32, and BT3.33.

Bid Rates are the rates bid by Purchaser (exclusive of Required Deposits for slash disposal and road maintenance) and are the sum of Advertised Rates and Bid Premium Rates. Until a rate redetermination becomes effective, the Bid Rate for species and products in AT4a is the Tentative Rate that is subject to quarterly adjustment under BT3.2; for species and products in AT4b, the Bid Rate is the Flat Rate.

Required Deposits are deposits that Purchaser may be required to pay for slash disposal (16 USC 490) and road maintenance (16 USC 537). Required Deposits may be adjusted as part of a rate redetermination or a Contract Term Extension. The table shows only Required Deposits for slash disposal; road maintenance deposits, if any, are given in CT5.32#.

Base Index is the specified average of the lumber or other product selling value index used as the basis for computing adjustment in rates for variance in product selling value, as provided in BT3.2.

AT5 - Indices Used in Quarterly Adjustment, applicable to BT3.2

Not Applicable

AT6 - High Stumps, applicable to BT6.412

Species	Product	Maximum Stump Height (inches)
All	Sawtimber	14
All	Pulpwood	10

AT7 - Specified Roads, applicable to BT5.2

Name and Date of Governing Road Specifications: FP-14 Federal Highway Administration Standard Specifications for Construction of Roads and Bridges on Federal Highway Projects, as amended and supplemented (English)

Project		Design Class	Approx. Length (mi./km.)	Sheet Numbers and Approval Date	Performance Responsibility		
Road No.	Name				Survey	Design	Construction Staking ^{1/}
1157-F	FDR1157-F (C) (segment .31 to .31)	Single Lane - 5 mph	0 / 0	SR 1 - SR 26 09/27/2018	FS	FS	FS AC
1157-F	FDR1157-F (C) (segment .65 to .65)	Single Lane - 5 mph	0 / 0	SR 1 - SR 26 09/27/2018	FS	FS	FS AC
1157-F	FDR1157-F (C) (segment .87 to 1.06)	Single Lane - 5 mph	.19 / .31	SR 1 - SR 26 09/27/2018	FS	FS	FS AC
1157-F	FDR1157-F (C) (segment 1.03 to 1.03)	Single Lane - 5 mph	0 / 0	SR 1 - SR 26 09/27/2018	FS	FS	FS AC
1157-G	FDR1157-G (C) (segment .5 to .5)	Single Lane - 5 mph	0 / 0	SR 1 - SR 26 09/27/2018	FS	FS	FS AC
1157-G2	FDR1157-G2 (C) (segment .4 to .4)	Single Lane - 5 mph	0 / 0	SR 1 - SR 26 09/27/2018	FS	FS	FS AC
1157-G	FDR1157-G (R) (segment 0 to .54)	Single Lane - 5 mph	.54 / .87	SR 1 - SR 26 09/27/2018	FS	FS	FS AC
1157-G2	FDR1157-G2 (R) (segment 0 to .4)	Single Lane - 5 mph	.4 / .64	SR 1 - SR 26 09/27/2018	FS	FS	FS AC
1157-H	FDR1157-H (R) (segment 0 to .03)	Single Lane - 5 mph	.03 / .05	SR 1 - SR 26 09/27/2018	FS	FS	FS AC

^{1/} Indicate timing, i.e., before clearing (BC) or after clearing (AC). Applicable to BT5.212.

AT8 - Forest Service Engineering Completion Schedule, applicable to BT5.21

Road No.	Road Name	Type of Work	Completion Date
NOT APPLICABLE			

AT9 - Fire Precautionary Period, applicable to BT7.2

April 01 to November 15, inclusive

AT10 - Purchaser Responsibility to Furnish Crews and Equipment for:

Initial Fire Suppression, applicable to BT7.3

Within 5.0 road miles

Fire Suppression Reinforcement, applicable to BT7.312 and BT7.313

Within 20.0 road miles

AT11 - Purchaser's Obligation per Operations Fire, applicable to BT7.41

Maximum Amount: \$ \$1,000

AT12 - Termination Date, applicable to BT8.2

September 30, 2024

AT13 - Normal Operating Season, applicable to BT6.31, BT6.66, BT8.21 and BT9.3

First Period: December 15 to March 15 , inclusive

Second Period: _____ to _____ , inclusive

AT14 - Performance Bond, applicable to BT9.1

Performance Bond Amount: _____

AT15 - Downpayment, applicable to BT4.211

Downpayment Amount: _____

AT16 - Periodic Payment Amount, applicable to BT4.213

	<u>Periodic Payment Determination Date</u>	<u>Amount</u>
Initial Payment:	_____	_____
Additional Payment:	_____	_____

AT17 - Market-Related Contract Term Addition Producer Price Index, applicable to BT8.212

Index Name: Wood Chips **Index Number:** 3211135

AT18 - Inapplicable Standard Provisions

The following listed Sections, Subsections, or Items of Division BT - Standard Provisions - are hereby made inapplicable. (Instructions: List by reference number and title.)

- BT4.211 DOWNPAYMENT
- BT4.4 PAYMENTS NOT RECEIVED
- BT8.212 MARKET-RELATED CONTRACT TERM ADDITION
- BT8.64 DEBARMENT AND SUSPENSION CERTIFICATION

AT19 - List of Special Provisions

The following listed special provisions are attached to and made a part of this contract as Division CT. Provisions with reference numbers followed by # contain blanks into which data have been entered for this sale. (Instructions: List by reference number, title, and date.)

- CT2.301# PROTECTED AREAS (06/2009)
- CT2.302# BOUNDARY TREES (06/2009)
- CT2.352# DESIGNATION BY SPECIES AND DIAMETER (04/2004)
- CT2.355# INDIVIDUAL TREES, CUT TREE MARKING (06/2009)
- CT4.211 DOWNPAYMENT (06/2007)
- CT4.212 TEMPORARY REDUCTION OF DOWNPAYMENT (08/2009)
- CT4.4 PAYMENTS NOT RECEIVED (08/2012)
- CT5.12# USE OF ROADS BY PURCHASER (06/1999)
- CT5.213# DEPOSIT FOR RECONSTRUCTION ENGINEERING SERVICES (04/2004)
- CT5.221# MATERIAL SOURCES (04/2004)
- CT5.31# ROAD MAINTENANCE REQUIREMENTS (07/2001)
- CT5.32# ROAD MAINTENANCE DEPOSIT SCHEDULE (08/2012)
- CT5.33# SNOW REMOVAL (06/2009)
- CT6.314# OPERATING REQUIREMENTS (06/2009)
- CT6.412 STUMP MARKS (06/2009)
- CT6.42# SKIDDING AND YARDING REQUIREMENTS (06/2009)
- CT6.62# SITE SPECIFIC WETLANDS PROTECTION MEASURES (07/2001)
- CT6.7# SLASH DISPOSAL MEASURES (06/2009)
- CT7.2 FIRE PRECAUTIONS (06/2009)
- CT8.212 MARKET-RELATED CONTRACT TERM ADDITION (11/2008)

CT8.64

DEBARMENT AND SUSPENSION CERTIFICATION (03/2018)

There are no pages 108 & 109.

Sale Name: Change Out PR

CT2.301# - PROTECTED AREAS (06/2009)

Notwithstanding the designations for cutting under standard provisions BT2.31, BT2.33, BT2.34 and BT2.35, trees within the area to be protected in Payment Unit(s) 07 shall be left uncut. Boundary trees along the perimeter of Protected Areas have been identified by 3 orange painted slashes and "PA" facing away from the Protected Area and orange painted stump mark. BOUNDARY TREES ARE NOT TO BE CUT. Sale Area Map indicates, with symbol "PA," units within which Protected Areas are identified on the ground and are to be left uncut.

CT2.302# - BOUNDARY TREES (06/2009)

Boundary trees for all harvest units have been designated with 3 slashes on exterior Boundaries and 2 slashes on interior/common Boundaries, all slashes face into Payment Unit and are comprised of Orange paint marks above and below stump height. Boundary trees shall not be cut.

CT2.352# - DESIGNATION BY SPECIES AND DIAMETER (04/2004)

Trees that meet Utilization Standards are designated for cutting, as shown on the Tree Designation Table and Sale Area Map, except trees Marked with Orange paint or described to be left uncut.

See Tree Designation Table.

Additional trees to be cut, if any, are Marked with Blue paint.

All N/A shall be left as leave trees, unless Marked with N/A paint. Leave N/A trees of the designated cut species, N/A inches stump diameter or greater, to avoid leave tree spacing greater than N/A feet. Cutting unit boundaries and other trees that shall be left uncut are Marked with Orange paint.

Distances are measured horizontal distance, outside bark stump height to outside bark stump height. Stump diameter is measured outside bark at stump height in a horizontal and is the average of a measurement across the short axis through the true center of the stump and a second measurement at right angles to the short axis.

Purchaser and Forest Service shall agree to skid trail location under BT6.422. Skid trails shall be no greater than N/A feet wide with a N/A foot spacing. Quantities of trees located in skid trails are not (unless included as a designated species in Tree Designation Table) Included Timber under AT2.

Sale Name: Change Out P.R.

Page 142

CT2.352# - DESIGNATION BY SPECIES AND DIAMETER. (04/04)

Tree Designation Table

Payment Unit(s)	Designated Species	More Than Stump Diameter (inches)	Less Than Stump Diameter (inches)
06, 07 & 09	All merchantable trees EXCEPT hemlock, cedar, white and red pine.	>= 6.0"	N/A

Sale Name: Change Out PR

CT2.355# - INDIVIDUAL TREES, CUT TREE MARKING (06/2009)

Individual trees to be cut are Marked with indicated color above and below stump height in all or parts of the following Payment Unit(s). Areas of cut tree marking are shown on the Sale Area Map with the symbol "CTM."

PAYMENT UNIT(S)

PAINT COLOR

**Change Out P.R. Timber Sale
Individual Trees, Cut Tree Marking (06/2009) – CT2.355#**

Cut Tree Marking Table

Payment Units	Paint Color
01-05, 08, & 10-12	BLUE
13 (Roads)	YELLOW

Sale Name: Change Out PR

CT4.211 - DOWNPAYMENT (06/2007)

The downpayment amount shown in AT15 may not be applied toward any other payment required under the provisions of this contract, except damages determined pursuant to BT9.4, transferred to other timber sales, or refunded until (a) stumpage value representing 25 percent of the total bid value of the timber sale is shown on Timber Sale Account to have been cut, removed, and paid for, or (b) the estimated value remaining to be cut and removed, as shown on Timber Sale Account, is equal to or less than the amount of the downpayment, or (c) if 36 CFR 223.49(e) is applicable, the estimated value remaining to be cut and removed, as shown on Timber Sale Account, is equal to or less than the amount of the downpayment. For lump sum timber sales, the downpayment may be applied to payment for release of the single payment unit.

If Forest Service makes a determination that this contract should not have been included under increased downpayment requirements (36 CFR 223.49(e)), the downpayment shall be revised and applied in accordance with 36 CFR 223.49(f).

CT4.212 - TEMPORARY REDUCTION OF DOWNPAYMENT (08/2009)

Notwithstanding BT4.211 or CT4.211, upon the Purchaser's written request Forest Service may temporarily reduce the downpayment when Purchaser's scheduled operations are delayed or interrupted for 30 or more consecutive days, or the contract term is extended for 30 or more consecutive days for any of the following reasons:

- (1) Forest Service requests or orders Purchaser to delay or interrupt scheduled operations for reasons other than breach;
- (2) Purchaser interrupts or delays scheduled operations to work on a sale designated by the Forest Service as in urgent need of harvesting; or
- (3) An adjustment of the contract term authorized upon a determination of substantial overriding public interest, including a market-related contract term addition, or an urgent removal contract term extension under 36 CFR 223.53.

When Purchaser is not cutting or removing timber under contract during a qualifying period of delay, interruption, or extension listed above the downpayment may be reduced to \$1000 or 2 percent of the downpayment amount stated in the contract, whichever is greater. The Purchaser must restore the downpayment to the full amount stated in the contract within 15 days from receipt of the bill for collection and written notice from the Contracting Officer that the basis for temporarily reducing the downpayment no longer exists. Purchaser shall not cut or remove timber on a contract where the downpayment has been temporarily reduced until the downpayment amount stated in the contract is fully restored.

Sale Name: Change Out PR

CT4.4 - PAYMENTS NOT RECEIVED (08/2012)

(a) Payments are due and payable on the date of issue indicated on the bill for collection. When a payment for timber cut and other charges is not received at the location designated by Forest Service by the date specified in the bill for collection, Contracting Officer will suspend all or any part of Purchaser's Operations until payment or acceptable payment guarantee is received. Other charges include, but are not limited to:

- (i) Slash disposal and road maintenance deposits;
- (ii) Cooperative work at rates established by specific agreement under BT4.218;
- (iii) Damages pursuant to BT9.4;
- (iv) Road use fees;
- (v) Restoration of downpayment pursuant to BT4.22;
- (vi) Periodic payments pursuant to BT4.213;
- (vii) Extension Deposits pursuant to BT4.217; and
- (viii) Other mandatory deposits.

(b) Failure to pay amounts due by the date specified in the bill for collection shall be considered a breach under BT9.3. The 30-day notice period prescribed therein shall begin to run as of the end of business on the date specified for receipt of payments. If the performance or payment is guaranteed by surety bond, the surety will receive a copy of the written notification of breach. Demand will be made on the surety or other institution providing the guarantee or bond instrument for immediate payment 10 days after issuance of written notification of the breach.

(c) Pursuant to the Debt Collection Improvement Act of 1996, as amended, if payment is not received by Forest Service within 15 days after the date of issue indicated on the bill for collection:

(i) Simple interest shall be assessed at the Current Value of Funds Rate as established by the Secretary of the Treasury. Interest will begin to accrue as of the date of issue indicated on the initial bill for collection.

(ii) Debtors will be assessed administrative charges, in addition to the delinquent amount due. Administrative charges are those additional costs incurred by the Government in processing, handling, and collecting delinquent debts.

(iii) A penalty charge of six (6) percent per annum will be assessed on any portion of a debt delinquent more than 90 days. This penalty charge is in addition to interest and administrative charges under paragraphs (c) (i) and (c) (ii). The penalty charge shall accrue from the date of issue indicated on the bill for collection and shall be assessed on all outstanding amounts, including interest and administrative costs assessed under paragraphs (c) (i) and (c) (ii).

(iv) Payments will be credited on the date received by the Federal Depository or Collection Officer designated on the bill for collection.

(d) Forest Service remedies for Purchaser's failure to make payment for timber cut and other charges when due, except for accrual of interest, suspension of all or any part of Purchaser's Operations, and administrative offset, shall be stayed for so long as:

- (i) A bona fide dispute exists as to Purchaser's obligation to make such payment and
- (ii) Purchaser files and prosecutes a timely Claim.

Sale Name: Change Out PR

CT5.12# - USE OF ROADS BY PURCHASER (06/1999)

Purchaser's use of existing roads identified on Sale Area Map by the following codes is prohibited or subject to restrictive limitations, unless agreed otherwise:

Code	Use Limitations
X	Hauling prohibited
R	Hauling restricted
U	Unsuitable for hauling prior to completion of agreed reconstruction
P	Use prohibited
A	Public use restriction
W	Regulation waiver

Roads coded A will be signed by the Forest Service to inform the public of use restrictions. Purchaser's use of roads coded R, A, or W shall be in accordance with the following restrictions:

See Restricted Road List Table.

**Change Out P.R. Timber Sale
Use of Roads by Purchaser (06/1999) – CT5.12#**

Restricted Road List

Road Number	Road Name	Termini (miles)		Map Legend	Description of Restrictions
		From	To		
FR 1100	FR 1100	Intersec- tion with FR 1157 going north	Pori Road Intersect ion	X	Haul Prohibited.
FR 1157-A	FR 1157-A	POB	POE	X	Haul Prohibited.
FR 1157-AA	FR 1157-AA	POB	POE	X	Haul Prohibited.
FR 1157-B	FR 1157-B	POB	POE	X	Haul Prohibited.
FR 1157-E	FR 1157-E	POB	POE	X	Haul Prohibited.
FR 1157-G	FR 1157-G	POB	0.54	U	Unsuitable for Hauling prior to agreed upon Reconstruction.
FR 1157-G	FR 1157-G	0.54	POE	X	Haul Prohibited.
FR 1157-G2	FR 1157-G2	POB	POE	U	Unsuitable for Hauling prior to agreed upon Reconstruction.
FR 1157-H	FR 1157-H	POB	0.03	U	Unsuitable for Hauling prior to agreed upon Reconstruction.
FR 1157-H	FR 1157-H	0.03	POE	P	Use Prohibited.

POB = Point of Beginning

POE = Point of Ending

Note: hauling includes empty or loaded log trucks.

Sale Name: Change Out PR

CT5.213# - DEPOSIT FOR RECONSTRUCTION ENGINEERING SERVICES (04/2004)

Purchaser shall make a cash deposit for engineering services (preconstruction and construction) provided by Forest Service for reconstruction of National Forest system roads necessary to accommodate Purchaser's use under this contract, pursuant to 16 USC 537.

The total amount to be deposited by Purchaser for reconstruction related engineering services to be completed by Forest Service personnel or by public works contract is \$1,132.00. Purchaser shall make this deposit at the end of the first full Normal Operating Season or 12 months from contract award, whichever occurs first. In the event a different deposit schedule is agreed to, such deposit shall be due within 15 days after the date of issue indicated on the initial bill for collection, pursuant to BT4.4.

The amount of the required deposit will be shown as an associated charge on Purchaser's Timber Sale Account. Forest Service shall retain any unexpended deposit for reconstruction related engineering services.

The deposit for reconstruction related engineering services shall be commensurate with project need and Purchaser's road use. Forest Service shall complete reconstruction related engineering services on the following schedule unless a different completion schedule is agreed in writing:

Road or Facility No.	Termini From To	Engineering Services Completion Date
----------------------	--------------------	---

N/A

Reconstruction related engineering services may consist of some or all of the engineering work and expense of: preparing, setting out, controlling, inspecting, and measuring the reconstruction of a National Forest system road.

Sale Name: Change Out PR

CT5.221# - MATERIAL SOURCES (04/2004)

Sources of local materials are designated on Plans and Sale Area Map. Forest Service assumes responsibility for the quality and quantity of material in designated sources. Purchaser shall determine the equipment and work required to produce the specified product, including the selection of acceptable material that is reasonably available in the source that meets specifications. The designation of source includes the rights of Purchaser to use certain area(s) for plant site, stockpiles, and haul roads.

Should the designated source, due to causes beyond the control of Purchaser, contain insufficient acceptable material, Forest Service will provide another source with adjustment in accordance with BT5.253.

When Purchaser elects not to use designated sources, Purchaser shall furnish the specified product with no adjustment in unit rates. Quality testing shall be the responsibility of Purchaser. Test results shall be furnished to Forest Service.

When Purchaser elects not to use designated sources and the Schedule of Items lists pit development separately, cost allowance will be reduced under BT5.253 when Forest Service determines the work will not be required.

When materials are subject to a weight measurement, the specific gravity or weight/volume relationship used as a basis for determination of estimated quantities shall be:

Source I N/A, Source II N/A, and Source III N/A.

Purchaser may, when agreed in writing, use on the project such suitable stone, gravel, and sand, or other material found in the excavation, and will earn a cost allowance for the excavation of such materials at the corresponding contract unit price and for the pay items for which the excavated material is used. Purchaser shall replace, without additional cost allowance, sufficient suitable materials to complete the portion of the work, which was originally contemplated to be constructed with such material. Purchaser shall not excavate or remove any material, except that which is within the excavation limits, without written authorization from Forest Service.

When material is appraised from non-National Forest designated sources, owner charges for the material in terms of unit cost for royalties, purchase of raw materials, or finished products shall be as follows until N/A:

See Material Source Table.

Should quantity vary from that estimated, payment to owners shall be for units actually obtained. Purchaser shall make arrangements with owner(s) for measurement and payment for royalties, purchase of raw materials, or finished products, as shown above.

Materials produced or processed from National Forest lands in excess of the quantities required for performance of this contract are the property of Forest Service, unless prior written agreement has been obtained to use excess material on other National Forest sales. Forest Service is not obligated to reimburse Purchaser for the cost of their production.

Materials shall be stored to assure the preservation of their quality and fitness for the work. Stored materials shall be located to facilitate their prompt inspection. Sites on Forest Service administered land, approved by Forest Service, may be used for storage purposes and for the placing of Purchaser's plant equipment. All storage sites provided by Forest Service shall be restored at Purchaser's expense. Purchaser shall be responsible for making arrangements for storage on other than Forest Service adminis-

Sale Name: Change Out PR

tered lands.

When the construction of the portion of the project for which Temporary Roads used for hauling materials is completed, all such Temporary Roads shall be restored as nearly as practicable to their original ground profile, unless otherwise agreed in writing.

Sale Name: Change Out P.R.

Page 152

FS-2400-6T (04/04)

WO-CT5.221# - MATERIAL SOURCES. (04/04)

Material	Type of Purchase	Owner(s)	Unit of Measure	Unit Price	Estimated Quantity	Total
N/A	N/A	N/A	N/A	N/A	N/A	N/A

Sale Name: Change Out PR

CT5.31# - ROAD MAINTENANCE REQUIREMENTS (07/2001)

Purchaser shall maintain roads in accordance with the following Contract Road Maintenance Requirements Summary:

See Contract Road Maintenance Requirements Summary Table.

**Change Out P.R. Timber Sale
Road Maintenance Specifications – CT5.31#**

SECTION 3. ROAD MAINTENANCE REQUIREMENTS SCHEDULE

Applicable Prehaul Road Maintenance Specifications												
Termini												
Road	From	To	Miles	T-8030	T-8110	T-8130	T-8310	T-8340	T-8350	T-8360	T-8420	T-8620
1100	4.80	10.7	5.9	P								
1157	0.00	1.57	1.57	P			P			P	P	
1157-F	0.00	0.87	0.87	P			P			P	P	
P = Purchaser Performance Item, D = Deposit to Forest Service, D3 = Deposit to Third Party												

Applicable During Haul Road Maintenance Specifications												
Termini												
Road	From	To	Miles	T-8030	T-8110	T-8130	T-8310	T-8340	T-8350	T-8360	T-8420	T-8620
1100	4.80	10.7	5.9	P	D	D	D	D			D	
1157	0.00	1.57	1.57	P		P*	P	P		P		
1157-F	0.00	1.06	1.06	P		P*	P	P		P		
1157-G	0.00	0.54	0.54	P		P*	P	P		P		
1157-G2	0.00	0.40	0.40	P		P*	P	P		P		
1157-H	0.00	0.03	0.03	P		P*	P	P		P		
P = Purchaser Performance Item, D = Deposit to Forest Service, D3 = Deposit to Third Party												
*100 Cubic Yards of During Haul gravel allowance to be placed as agreed to with the Forest Service												

Applicable Post Haul Road Maintenance Specifications												
Termini												
Road	From	To	Miles	T-8030	T-8110	T-8130	T-8310	T-8340	T-8350	T-8360	T-8420	T-8620
1100	4.80	10.7	5.9		D	D	D	D	D		D	
1157	0.00	1.57	1.57				P	P	P	P		P
1157-F	0.00	1.06	1.06				P	P	P	P		
1157-G	0.00	0.54	0.54				P	P	P	P		
1157-G2	0.00	0.40	0.40				P	P	P	P		
1157-H	0.00	0.03	0.03				P	P	P	P		
P = Purchaser Performance Item, D = Deposit to Forest Service, D3 = Deposit to Third Party												

Sale Name: Change Out PR

CT5.32# - ROAD MAINTENANCE DEPOSIT SCHEDULE (08/2012)

Other provisions herein notwithstanding, when Forest Service requests payment in lieu of Purchaser's performance of road maintenance, Purchaser shall make Required Deposits (16 USC 537) for current and/or deferred road maintenance. Such deposits are based on the estimated volume and distance hauled and Purchaser's commensurate use of each road listed in the Road Maintenance Plan in CT5.31#.

Purchaser and Forest Service may agree in writing on adjustment of such rates. If Purchaser uses roads under jurisdiction of Forest Service other than those listed in the Road Maintenance Plan, Forest Service shall establish rates commensurate with Purchaser's use of such roads.

The Required Deposits for Forest Service work in lieu of Purchaser performance are \$2.77 per CCF for recurrent maintenance, and \$2.78 per CCF for deferred maintenance.

The following table lists who Purchaser will make deposits for road maintenance to, and the rate per unit of measure of the deposit. The Road Maintenance Agreement is available for inspection at the Forest Supervisor's office.

Deposit Made To	Rate	Unit of Measure
N/A		

CT5.33# - SNOW REMOVAL (06/2009)

Snow removal shall be done in a manner that will preserve and protect roads, provide for safe and efficient transport of timber, and prevent erosion damage to streams and adjacent lands. In performing snow removal, Purchaser shall adhere to the following performance standards, unless otherwise agreed:

1. Blade will be equipped with skid shoes to prevent loss of surfacing and damage to the road bed. On gravel and native surface roads, a minimum 4-inch depth compacted snow mat will be maintained on the roadbed during blading.
2. Snow shall be removed from the entire road width, including turnouts.
3. Snow berms will be reduced at road intersections where plowed road segments join unplowed road segments. Reduce the piled snow in the roadway to create a smooth transition from plowed road to normal snow depth.
4. Openings will be created in snow berms as needed for proper drainage. Remove snow, ice, and debris from culverts and other drainage structures as needed to ensure efficient flow of water.
5. Tracked or clefted vehicles will not be used for snow removal without prior written approval of Forest Service Representative.

Sale Name: Change Out PR

CT6.314# - OPERATING REQUIREMENTS (06/2009)

Within Sale Area, unless changed by written agreement, the following operating requirements apply:

Restricted operations/activities:

Payment Unit 01 and 09: Harvesting operations are restricted during the period of March 16 through June 30 and October 1 through December 14 (due to soils).

Payment Unit 02 through 05, 08, 10 and 11: Harvesting operations are restricted during the period of March 16 through July 31 and October 1 through December 14 (due to soils).

Payment Unit 06 and 07: Harvesting operations are restricted during the period of March 16 through December 14 (due to soils).

Payment Unit 12: Harvesting operations are restricted during the period of March 16 through May 15 (due to soils).

Prohibited operations/activities:

N/A

CT6.412 - STUMP MARKS (06/2009)

Trees designated for cutting under BT2.35 have been marked with paint at breast height and below stump height. Trees shall be felled so as to leave paint on stump.

CT6.42# - SKIDDING AND YARDING REQUIREMENTS (06/2009)

As used in this provision, skidding equipment includes rubber-tire and track-mounted skidders, forwarders, fell bunchers, processors and any other mechanized equipment that is used off of landings and roads.

Within Payment Unit(s)

N/A,

N/A.

Within portions of Payment Unit(s)

01, southern 3 parcels , as shown on Sale Area Map with symbol "SYR," Harvested products must be skidded/forwarded out of this parcel of the unit to an approved landing/decking location.

Sale Name: Change Out PR

CT6.62# - SITE SPECIFIC WETLANDS PROTECTION MEASURES (07/2001)

Measures needed to protect wetlands identified on the Sale Area Map or on the ground include:

Trees felled into Wetlands Protection areas shall be removed by endlining and any slash generated by the Purchaser's operations shall be removed as directed by the Forest Service.

CT6.7# - SLASH DISPOSAL MEASURES (06/2009)

Slash resulting from Purchaser's operations shall be removed from lakes, ponds, private land, right-of-way clearings for telephone lines, power lines, pipelines, and other authorized facilities, and landings to be seeded under Special Provision CT6.6#.

The tops of felled trees shall not be left hanging in standing trees. All trees cut or pushed for landing and other construction clearings shall be completely felled and not left leaning. Slash resulting from construction clearing shall be treated concurrent with operations.

Slash Disposal treatment zones are shown on the Sale Area Map with symbol "SDZ."

Other specific slash disposal requirements are as follows:

All slash resulting from construction clearing (such as from landings, temporary roads, ROW clearing associated with pre-haul road maintenance requirements listed in CT5.31#), including Specified Road construction, shall be lopped and scattered to lie within 3 feet of the ground. All root wads shall be severed from the stem and righted on the ground or otherwise disposed of as directed by the Forest Service, concurrent with operations.

Within Payment Units 01 - 12 except as specified elsewhere in this contract; all slash generated by the Purchaser's operations shall be evenly distributed throughout the Payment Unit and away from the base of residual trees concurrent with operations.

Logging slash and stumps used in the construction of road closure berms are excluded from these Slash Disposal Measures.

-

Sale Name: Change Out PR

CT7.2 - FIRE PRECAUTIONS (06/2009)

Unless other methods are agreed to in writing between the Purchaser and the Contracting Officer, the following specific precautionary measures are applicable during Purchaser's Operations in Fire Precautionary Period indicated in AT9.

1. Purchaser shall maintain Forest Service-approved spark arresting device on any piece of equipment operated by an internal combustion motor. In addition, each piece of motorized equipment shall be equipped with a serviceable round-pointed shovel and an operational fire extinguisher of at least five-pound rating suitable for the equipment being used. All chainsaw operators will have a serviceable round-pointed shovel and a one-pound multipurpose fire extinguisher readily available.
2. Purchaser shall require that smoking and the building of lunch or warming fires by Purchaser's employees, contractors, or employees of contractors be confined to designated safe places where flammable debris has been cleared away and where, at the option of the Purchaser, smoking or the building of lunch or warming fires may be permitted.
3. Adequate spark arresters shall be maintained on chimneys or stovepipes where wood or coal is being burned in an enclosed device.
4. Purchaser shall furnish serviceable firefighting tools. Location, numbers, and types of tools shall be specified in the Fire Prevention and Control Plan in accordance with BT7.1.

CT8.212 - MARKET-RELATED CONTRACT TERM ADDITION (11/2008)

The term of this contract may be adjusted when a drastic reduction in wood product prices has occurred in accordance with 36 CFR 223.52. The Producer Price Index used to determine when a drastic reduction in price has occurred is stated in AT17. Purchaser will be notified whenever the Chief determines that a drastic reduction in wood product prices has occurred. If the drastic reduction criteria specified in 36 CFR 223.52 are met for 2 consecutive calendar quarters, after contract award date, Contracting Officer will add 1 year to the contract term, upon Purchaser's written request. For each additional consecutive quarter such a drastic reduction occurs, Contracting Officer will, upon written request, add an additional 3 months to the term during Normal Operating Season, except that no single 3-month addition shall extend the term of the contract by more than one year. Contracting Officer must receive Purchaser's written request for a market-related contract term addition before the expiration of this contract.

No more than 3 years shall be added to a contract's term by market-related contract term addition unless the following conditions are met:

(i) The sale was awarded after December 31, 2006; and

(ii) A drastic reduction in wood product prices occurred in at least ten of twelve consecutive quarters during the contract term, but not including the quarter in which the contract was awarded.

For each qualifying quarter meeting the criteria in paragraphs (i) and (ii) of this provision, the Forest Service will, upon the Purchaser's written request, add an additional 3 months during the normal operating season to the contract, except no single 3-month addition shall extend the term of a contract by more than 1 year.

In no event shall a revised contract term exceed 10 years as a result of market-related contract term addition.

Additional contract time may not be granted for those portions of the contract that have a required completion date or for those portions of the contract where Contracting Officer determines that the timber is in need of urgent removal or that timber deterioration or resource damage may result from delay.

Sale Name: Change Out PR

CT8.64 - DEBARMENT AND SUSPENSION CERTIFICATION (03/2018)

Pursuant to 2 CFR 180 and 2 CFR 417, Purchaser shall certify and obtain certifications from its Subcontractors regarding debarment, suspension, ineligibility, and voluntary exclusion, including additional Subcontractors obtained after award of this contract. 'Subcontractors' are participants in lower tier covered transactions.

Purchaser may rely upon a certification of a prospective Subcontractor that it is not proposed for debarment under 48 CFR 9.4, debarred, suspended, ineligible, or voluntarily excluded from participating in covered transactions or timber sales, unless Purchaser knows that the certification is erroneous.

Purchaser shall keep the certifications of its Subcontractors on file until timber sale Termination Date and any extensions thereof, and will provide a copy at the written request of Contracting Officer. Nothing contained in the foregoing shall be construed to require establishment of a system of records in order to render in good faith the certification required by this Subsection. The knowledge and information of Purchaser is not required to exceed that which is normally possessed by a prudent person in the ordinary course of business dealings.

If Purchaser knowingly enters into a timber sale transaction with a person who is proposed for debarment under 48 CFR 9.4, suspended, debarred, ineligible, or voluntarily excluded from participation in covered transactions or timber sales, in addition to other remedies available to the Government, Forest Service may pursue available remedies, including suspension and/or debarment.

Contracting Officer shall provide a copy of Forms AD-1047, Certification Regarding Debarment, Suspension and Other Responsibility Matters-Primary Covered Transactions, and AD-1048, Certification Regarding Debarment, Suspension, Ineligibility and Voluntary Exclusion-Lower Tier Covered Transactions to the Purchaser.

Purchaser shall complete form AD-1047 and provide to the Contracting Officer upon request.

Purchaser shall require each Subcontractor to complete form AD-1048 and provide to the Contracting Officer upon request.

Change Out P.R. TIMBER SALE ROAD MAINTENANCE REQUIREMENTS
FS-2400-6T Contracts (06/06)
CT5.31# Special Provisions

SECTION 1. GENERAL

Purchaser's main Road Maintenance responsibility begins: (1) after Purchaser performs Prehaul Maintenance on a road listed in the Road Maintenance Requirements Schedule; or (2) for all other roads, when Purchaser begins to use the road. Occasional travel by Purchaser's light vehicles, prior to beginning of construction clearing or logging operations in the area accessed by the road, does not constitute beginning of use. Purchaser is not required to perform routine maintenance during periods of inactivity. During periods of inactivity, Forest Service will perform maintenance only as required to meet its needs.

The Purchaser shall maintain roads, commensurate with the Purchaser's use, in accordance with the Road Maintenance Requirements Summary and Road Maintenance Specifications. Performance of road maintenance work by the Purchaser may be required prior to, during, or after each period of use. The timing of work accomplishment shall be based on the Purchaser's operating schedule under Standard Provision **BT6.31**.

If the Purchaser elects to use different roads than those listed in the Road Maintenance Requirements Summary, the Contracting Officer (CO) or designee shall determine the Purchaser's commensurate share of road maintenance and/or revise road maintenance deposits.

Unless the CO or designee agrees in writing, all Prehaul Maintenance requirements shall be completed on any portion of road prior to hauling on that portion.

The Forest Service shall prepare a revised Road Maintenance Requirements Schedule to reflect changes in the original haul routes when needed.

Any work or materials that are determined to no longer be needed and are waived shall have the estimated cost charged to the Timber Sale Account as described in **BT8.31**.

SECTION 2. ROAD MAINTENANCE DEFINITIONS

Wherever the following terms are used in the Road Maintenance Specifications, the meaning shall be:

Base Course. Material placed on the Subgrade to distribute concentrated wheel loads.

Borrow. Select Material taken from designated borrow sites.

Crown, Inslope, and Outslope. The cross slope of the Traveled Way to aid in drainage and traffic maneuverability.

Culverts. A conduit or passageway under a road, trail, or other obstruction. A culvert differs from a bridge in that it is usually entirely below the elevation of the Traveled Way.

**Change Out P.R. TIMBER SALE ROAD MAINTENANCE REQUIREMENTS
FS-2400-6T Contracts (06/06)
CT5.31# Special Provisions**

Drainage Dip. A dip in the Traveled Way which intercepts surface runoff and diverts the water off the Traveled Way. A Drainage Dip does not block the movement of traffic.

Drainage Structures. Manufactured structures which control the runoff of water from the Roadway including Inslope, overside drains, aprons, flumes, downdrains and downpipes.

During Haul Maintenance. Road maintenance work to be accomplished during the period of timber removal.

Geotextile. A group of construction fabrics with varying attributes designed for different purposes.

Lead-off Ditches. A ditch used to transmit water from a Culvert, Drainage Structure or Drainage Dip outlet to the natural drainage area.

Maintenance Activity. Items of work leading to the restoration and upkeep of a road and necessary to sustain the road's anticipated traffic.

Material. Any substance specified for use in the performance of the work.

Post Haul Maintenance. Road maintenance work to be accomplished after timber removal is completed.

Prehaul Maintenance. Road maintenance work to be accomplished prior to the roads use. Roads receiving prehaul maintenance shall be shown on the Sale Area Map.

Road Maintenance Cost. An estimate of the cost to perform road maintenance activities; as determined by the Forest Service. Estimates may include any or all of the work activities listed in Section 4, Road Maintenance Activity Specifications.

Roadbed. The portion of a road between the intersection of Subgrade and sideslopes, excluding that portion of the ditch below Subgrade.

Roadside. A general term denoting the area adjoining the outer edge of the Roadway.

Roadway. The portion of a road within the limits of excavation and embankment.

Sand Hole. A hole that develops in the running surface of the road which is quite soft and dangerous in nature. Usually found in very sandy soils.

Shoulder. That portion of Roadway contiguous with Traveled Way for accommodation of stopped vehicles, for emergency use, and lateral support of Base and Surface Course, if any.

Slide. A concentrated deposit of materials from above or on backslope extending onto the Traveled Way or Shoulders, whether caused by mass land movements or accumulated ravelling.

Slough. Material eroded from the backslope which partially or completely blocks the ditch, but does not encroach on the Traveled Way so as to block passage of traffic.

Slump. A localized portion of the Roadbed which has slipped or otherwise become lower than that of the adjacent Roadbed and constitutes a hazard to traffic.

**Change Out P.R. TIMBER SALE ROAD MAINTENANCE REQUIREMENTS
FS-2400-6T Contracts (06/06)
CT5.31# Special Provisions**

Subgrade. Top surface of Roadbed upon which Base Course or Surface Course is constructed. For roads without Base Course or Surface Course, that portion of Roadbed prepared as the finished wearing surface.

Surface Course. The Material placed on the Base Course or Subgrade to enhance traction, distribute concentrated wheel loads and resist abrasion and the effects of climate. Surface Course may be referred to as surfacing.

Traveled Way. That portion of Roadway, excluding Shoulders, used for the movement of vehicles.

Turnouts. That portion of the Traveled Way constructed as additional width on single lane roads to allow for safe passing of vehicles.

SECTION 3. ROAD MAINTENANCE REQUIREMENTS SCHEDULE

See Summary in CT 5.31#.

SECTION 4. ROAD MAINTENANCE SPECIFICATIONS

INCLUDED SPECIFICATIONS

<u>Specification No.</u>	<u>Specification Title</u>
T-8030	Snow Removal
T-8130	Spot Surface Course Placement/Replenishment
T-8110	Maintenance Blading/Grading
T-8310	Ditch Cleaning
T-8340	Drainage Structure Maintenance
T-8350	Roadway Drainage Maintenance
T-8360	Composite High Clearance Road Maintenance
T-8420	Cutting Roadway Vegetation
T-8620	Miscellaneous Maintenance

T-8030 Snow Removal

DESCRIPTION

- 1.1 This Section provides for removal of snow from roads to facilitate logging operations and safe use. Remove snow from all or part of the traveled way, including sufficient turnouts for safe and efficient use for timber transportation and to protect the road. Remove intruding windfalls, debris or slough and slide material and dispose of only as necessary to provide passage for timber transportation. Removed materials may be deposited off the traveled way or outside the traveled way at locations designated by the Forest Service Representative (FSR). Snow may also be compacted as needed to freeze down soft areas or wet areas. This work is considered part of this specification. Equipment used for this work shall be in accordance with this specification and approved in advance by the FSR.

**Change Out P.R. TIMBER SALE ROAD MAINTENANCE REQUIREMENTS
FS-2400-6T Contracts (06/06)
CT5.31# Special Provisions**

EQUIPMENT

- 2.1 Purchaser may use any type of equipment to remove snow, providing:
- a. Type or use of equipment is not restricted in **CT5.12#** or Schedule document.
 - b. Equipment is of the size and type commonly used to remove snow and will not cause damage to the road. Tracked or cleated vehicles shall not be used unless approved in writing by the FSR.
 - c. The Blade will be equipped with skid shoes to prevent loss of surfacing and damage to the road bed. On gravel and native surface roads, a minimum 4 -inch depth compacted snow mat will be maintained on the roadbed during blading.

REQUIREMENTS

- 3.1 Erect signs required by the Sign Plan in the SUPPLEMENTAL SPECIFICATIONS or as shown on the Section 3. Road Maintenance Requirements Schedule. Perform work in a manner to preserve and protect roads and appurtenances, and prevent erosion damage to roads, streams, and other forest values.
- 3.2 Space, construct, and maintain drainage holes in the dike of snow or berm caused by snow removal operations. Place drain holes to obtain surface drainage without discharging on erodible fills.
- 3.3 Upon seasonal completion of Purchaser's Operations, effectively block the road by a snow barricade, unless otherwise approved by the Contracting Officer.
- 3.4 Ice control may be performed by Purchaser when approved by the FSR in writing. Such approval will include ice control materials, application rates, and any specific requirements of use.

Snow berms will be reduced at road intersections where plowed road segments join unplowed road segments. Reduce the piled snow in the roadway to create a smooth transition from plowed road to normal snow depth.

T-8130 Spot Surface Course Placement/Replenishment

DESCRIPTION

- 1.1 Spot Surface Course Placement/Replenishment includes Subgrade preparation, furnishing, hauling, spreading and shaping materials in accordance with the requirements.

MATERIALS

- 2.1 Surface Course Material will be in accordance with the subsection 3.2 of these specifications. Only commercial sources of aggregate will be accepted, except surfacing material may also be purchased from the government, where available, by filling out a form 2600, paying the required fees, and obtaining a permit.

**Change Out P.R. TIMBER SALE ROAD MAINTENANCE REQUIREMENTS
FS-2400-6T Contracts (06/06)
CT5.31# Special Provisions**

REQUIREMENTS

- 3.1** Subgrade Preparation. Prepare Subgrade to receive Surface Course Material at locations as designated on-the-ground by the Forest Service on roads listed below. Prepare the Subgrade by shaping the Roadbed to approximately the original cross-section and consistent with adjacent sections.
- 3.2** Furnish, haul and spread Material at locations designated on the ground by the Forest Service (FS). Compact the aggregate by operating spreading and hauling equipment over the full width of each layer of the aggregate, or by other methods as specified below.

Road Number	Type Material	Finished Compacted Thickness Specified	Total Quantity (Tons or cu.yds.)	Compaction Method
Any Purchaser Responsibility Road	Pit Run ^{1/}	(As needed and agreed to)	100 CY	See 3.2 Above

^{1/} Coming from Onion Creek Pit, haul, and place.

- 3.3** Variations. The Purchaser will be required to furnish weight tickets to the FS for each load of commercially obtained crushed aggregate prior to the final inspection. For aggregate purchased from the government, a count of truck loads will be required in addition to finished depth checks for the placed and compacted aggregate. Widths and lengths as staked or from schedule. When it is mutually agreed that all or part of the Surface Material is not needed, the estimated cost of surfacing not placed shall be charged to the Timber Sale Account in accordance with **BT8.31**.

T-8110 Maintenance Blading/Grading

DESCRIPTION

- 1.1** Maintenance Blading/Grading is keeping an aggregate surfaced Roadbed in a condition to facilitate traffic and provide proper drainage. It includes maintaining the Crown, Inslope or Outslope of the Traveled Way, Turnouts, and Shoulder; repairing Berms; blending approach road intersections; and cleaning Drainage Dips and Lead-off Ditches.

EQUIPMENT

- 2.1** The equipment required to shape, spread, and compact surfacing is listed below.

**Change Out P.R. TIMBER SALE ROAD MAINTENANCE REQUIREMENTS
FS-2400-6T Contracts (06/06)
CT5.31# Special Provisions**

Road Number	Road Termini - From	Road Termini - To	Equipment Description
1100	4.80	Skoglund Road Intersection	Motor-grader (or equivalent)

POB – Point of Beginning
POE – Point of Ending

REQUIREMENTS

- 3.1 Maintenance Blading/Grading shall be performed to facilitate traffic and proper drainage before, during, or after Purchaser's use as required by Section 3. Road Maintenance Requirements Schedule.
- 3.2 The surface blading shall preserve the existing cross-section. Surface irregularities shall be eliminated and the surface left in a smooth, free-draining state needed to facilitate traffic. Surface Course Material which has been displaced to the Shoulders or Turnouts shall be returned to the Traveled Way. The blading operation shall be conducted to conserve Surface Material and to provide for a thorough mixing of the Material being worked.
- 3.3 On aggregate surfaced roads Material generated from back slope Sloughing and ditch cleaning shall not be blended with Surface or Base Course Material unless agreed otherwise
- 3.4 Roadway back slopes shall not be undercut.
- 3.5 Drainage Dips and Lead-off Ditches shall be cleaned and maintained to retain the existing line, grade, and cross-section.
- 3.6 Intersecting roads shall be bladed for a distance of 50 feet to assure blending of the surfaces.
- 3.7 Rocks or other Material remaining on the Traveled Way after the final pass that are 4 inches in diameter or larger shall be removed. The unsuitable Material shall be disposed of by side casting unless agreed otherwise. Side casting into streams, lakes, or water courses will not be permitted.
- 3.8 Material resulting from this activity shall not remain on or in structures, such as Culverts, cattle guards, ditches, bridges, and Drainage Dips.
- 3.9 Material resulting from this activity, plus any accumulated debris, shall be removed from roadway structures, such as concrete low-water crossings or fords.

T-8310 Ditch Cleaning

DESCRIPTION

- 1.1 Ditch cleaning is the removal and disposal of all accumulated organic and Slough Material from Roadway ditches to provide a positive draining waterway of uniform width, depth, and grade.

**Change Out P.R. TIMBER SALE ROAD MAINTENANCE REQUIREMENTS
FS-2400-6T Contracts (06/06)
CT5.31# Special Provisions**

REQUIREMENTS

- 3.1 Ditch cleaning shall be repeated during sale operations as often as necessary to facilitate proper drainage.
- 3.2 All Slough Material or other debris which might obstruct water flow in the Roadway ditch shall be removed. Material removed from ditches that are not suitable for blending into the existing surface course shall be disposed of in places agreed to in writing by the FSR.
- 3.3 Roadway back slopes shall not be undercut.

T-8340 Drainage Structure Maintenance

DESCRIPTION

- 1.1 This work consists of maintaining and/or installation/removal of Drainage Structures and related items such as: inlet and outlet channels, existing riprap, trash racks, necessary geotextiles, pipes, and drop-inlets.

MATERIALS

- 2.1 All Materials used in the maintenance and/or installation/removal of Drainage Structures shall conform by type and specification to the Material in the structure being maintained or as indicated in the subsection 3.3 below.

REQUIREMENTS

- 3.1 Drainage Structures and related items shall be cleared of all foreign Material deposited above the bottom of the structure and all vegetative growth which interferes with the water flow. Material removed that cannot be incorporated into maintenance work shall be uniformly placed on fill slopes unless agreed otherwise.
- 3.2 Perform maintenance to insure the proper functioning of the head walls, aprons, inlet assemblies, riprap, trash racks and other facilities related to the Drainage Structure.
- 3.3 Install/remove ditches, drainage dips, rock crossings and/or culverts as shown below, and as marked on the ground. Installation of structures shall not begin without the presence of a FSR unless agreed to in writing by the FSR.
- 3.4 Installation shall be in accordance with construction industry standards and practices.
- 3.5 Culverts designated for removal/disposal shall become the property of the Purchaser and shall be disposed of properly.
- 3.6 Temporary culverts provided by the USFS shall remain the property of the government.

**Change Out P.R. TIMBER SALE ROAD MAINTENANCE REQUIREMENTS
FS-2400-6T Contracts (06/06)
CT5.31# Special Provisions**

3.7 Bridges. Any miscellaneous parts needing repair or replacement during normal use of any bridge during haul shall be considered maintenance. This includes minor items such as object markers, running planks that have loosened or cracked deck boards, or drainage structures which may become plugged. Bridge decks that are dirt and dust covered shall be cleaned to allow for proper drainage and for safety of the user.

T-8350 Roadway Drainage Maintenance

DESCRIPTION

1.1 This work consists of providing Post Haul drainage on roads.

MATERIALS

2.1 All Materials used in the maintenance and/or installation/removal of Drainage Structures shall conform by type and specification to the Material in the structure being maintained, or as indicated in subsection 3.3.

REQUIREMENTS

3.1 Upon completion of work, shape the roadway to provide for the removal of surface water. The roadway need not be passable to vehicles (ML-1 roads). Repair and reinstall waterbars, barriers or berms existing prior to the Purchaser's operation. Areas where water is ponded by existing centerline profile sags in through cuts may be left untreated.

3.2 Any of the following methods are acceptable for use at eroded or rutted locations:

- (a) Method A: Outsloping the roadbed at not less than ½ inch per yard of width.
- (b) Method B: Insloping the roadbed at not less than ½ inch per yard of width.
- (c) Method C: Water bar roadbed at locations staked on the ground and construct as shown on the enclosed detail.
- (d) Method D: Crown the roadbed as shown in the attached detail as the typical section for that length of road.

3.3 Drainage structures located in roadbed through fills and natural watercourses shall be fully functional without obstructions, including inlet and outlet channel within 20 feet of the structure.

3.5 Entrance Devices. Upon completion of work, replace entrance devices to effectively eliminate access by motorized vehicles (ML-1).

3.6 Seed and fertilize all disturbed areas in accordance with requirements set forth in T-8410 Vegetation Establishment.

**Change Out P.R. TIMBER SALE ROAD MAINTENANCE REQUIREMENTS
FS-2400-6T Contracts (06/06)
CT5.31# Special Provisions**

T-8360 Composite High Clearance Road Maintenance

DESCRIPTION

- 1.1 This work consists of making limited use roads passable for project use by Purchaser and providing drainage from the traveled way and roadbed.

MATERIALS

- 2.1 Required materials are listed in subsection 3.2.

REQUIREMENTS

3.1 Traveled Way

A. Purchaser may smooth or fill existing cross ditches and waterbars and, by agreement, modify existing road junction to enable vehicle access. Prior to beginning haul and resumption of haul after an extended stoppage:

1. Remove brush, fallen trees, rocks, and other debris from traveled way, including turnouts, turnarounds, and other locations that interfere with needed maintenance. No object extending over 4 inches above the road surface shall remain within the 12 feet usable traveled way.
2. Center the usable width of the roadbed or position away from the fill slope.
3. Cut and remove standing or down trees, logs, brush, and limbs from within the 12 feet usable traveled way. Remove encroaching limbs to a height of 14 feet above the traveled way surface. Scatter material not meeting utilization standards outside and below the roadbed on the fill side. Limb and remove designated timber which meets utilization standards or deck at agreed locations.
4. Place all removed material away from drainages and in locations previously agreed to in writing by the FSR.
5. During use, maintain drainage structures including dips, ditches and culverts in a usable condition and surface in a flat, Insloped or Outsloped, or Crowned usable condition.

3.2 Drainage Facilities. Clean and recondition drainage facilities in accordance with T-8310 Ditch Cleaning and T-8340 Drainage Structure Maintenance. **Maintain all other structures per 3.1, item 5 above within termini indicated in CT5.31# Summary Table.**

3.3 Slough and Slides

1. Slough and Slides may be left in place provided surface drainage is adequately provided and at least 12 feet of width is available for vehicle passage.
2. Purchaser may reposition or ramp over Slides and Slough when the Traveled Way is less

than 12 feet providing the material is capable of supporting vehicles. Limit Outslope to no more than six percent.

3. Reposition Slough or Slide materials, which are not capable of supporting a vehicle, on the roadbed to provide the 12 feet width. When directed by Forest Service, Slough or Slide material will be removed under Section T-8320 Slide, Slump, and Erosion Repair.

**Change Out P.R. TIMBER SALE ROAD MAINTENANCE REQUIREMENTS
FS-2400-6T Contracts (06/06)
CT5.31# Special Provisions**

3.4 Slumps, Eroded areas, and Washouts

1. Drain the roadbed immediately upgrade of Slumps and longitudinal cracks to prevent water from entering Slump area.
2. Slumps and longitudinal cracks at the edge of the roadbed shall not be considered a part of the usable width. Usable width may be reduced to ten feet in the area of the Slump.
3. Unless Forest Service agrees to material being placed on Slumps, ramp the Slumps on both ends into undisturbed roadbed to provide at least ten feet usable width. Use removed materials to guide vehicles to the ramp location or to aid in draining the area.
4. Eroded areas/washouts may be filled with suitable material and compacted by operating equipment over the fill area.

3.5 Posthaul

- A. At the end of hauling or prior to entering into seasonal shutdowns or a period of extended inactivity:
1. Shape the traveled way and disturbed roadbed to provide functional drainage.
 2. Reinstall removed cross ditches and waterbars and provide any additional drainage structures necessary to offset changes caused through use and maintenance.
 3. Leave roads useable for high clearance vehicles. Remove or reshape Purchaser modifications at road junctions to leave the entrance as it was before use, or as agreed at the time of improvement.
 4. Close all roads which were closed previously, using prior existing methodology.

T-8420 Cutting Roadway Vegetation

DESCRIPTION

- 1.1 This work includes removal of brush, trees and other vegetative growth from within the clearing limits. This may include brush mowing of shoulders to prevent larger growth which would inhibit travel in the future.

EQUIPMENT

- 2.2 Equipment use may include farm tractor mounted mowing or brushing equipment. If brushing equipment is required it must be of a size and power to cut off and masticate stems up to four inches in diameter. Larger growth may require hand clearing with a chainsaw or mechanized equipment able to handle larger trees.

REQUIREMENTS

- 3.1 Vegetative matter within the Roadway which impedes vehicular travel, and/or interferes with road maintenance operations, such as surface blading and ditch and culvert cleaning shall be removed. Downed timber meeting utilization standards shall be cut in appropriate lengths and decked in locations where agreed upon and the Traveled Way or sight distances will not be impaired.

**Change Out P.R. TIMBER SALE ROAD MAINTENANCE REQUIREMENTS
FS-2400-6T Contracts (06/06)
CT5.31# Special Provisions**

- 3.2 Vegetative matter removed from the clearing limits shall be scattered outside the clearing limits at least 3 (and lopped to within 3 feet of ground) feet perpendicular to the road surface.
- 3.3 Trim tree branches that extend over the road surface and shoulders to attain a clear height of 14 feet. Trim branches flush with the tree or as close as possible without causing damage or scarring to the bole. Area shall be left neatly trimmed.
- 3.4 Any stump removed shall be placed in an upright position out of the clearing limits.
- 3.5 Area shall not be left in an unsightly condition. The FSR shall have the final say over how the area is left.

T-8620 Miscellaneous Maintenance

DESCRIPTION

- 1.1 Maintenance of miscellaneous structures includes cattle guards, gates (this includes all types of closure devices such as logs, rocks, dirt berms, dirt and slash berms, metal gates, etc), signs, and other similar structures that have been previously installed to insure safe and efficient operation of the road.

MATERIALS

- 2.1 Any Materials needed in the maintenance of miscellaneous structures shall be similar in type and quality to the Material in the structure being maintained.

REQUIREMENTS

- 3.1 Cattle guards. Loose rails shall be welded or bolted back in place. Excess Material carried into the cattle guard shall be removed when drainage is blocked or when it reaches six inches from the bottom of the cattle guard frame. Drainage into and from the cattle guard shall be kept open.
- 3.2 Gates (and other closure devices). Gates shall be kept in good repair and made to swing easily. Hinges or latches shall be repaired if not operating properly. Brush and debris shall be removed from within the swinging radius. Weathered berms or wood piles shall be reconstructed to a height which discourages use and blocks the road.
- 3.3 Signs. Any signs needing repair or replacement shall be installed per sign placement detail or MUTCD direction. All roads shall have legible sign numbers. ML 3-5 roads shall have horizontal numbering and ML 1-2 roads shall have vertical numbers. The material used shall be as directed by the Forest Service Representative. All new signs must meet retro reflectivity requirements.

**Change Out P.R. TIMBER SALE ROAD MAINTENANCE REQUIREMENTS
FS-2400-6T Contracts (06/06)
CT5.31# Special Provisions**

Road Number	Road Name	Location	Remove/Install	Type of Item	Size	Quantity
1157	1157	MP 0.42	Remove/Install	Earthen Berm ^{1/}	^{2/}	1

^{1/} OHV passable berm

^{2/} Per Typical Drawing—Earthen Berms/Road Closure Devices

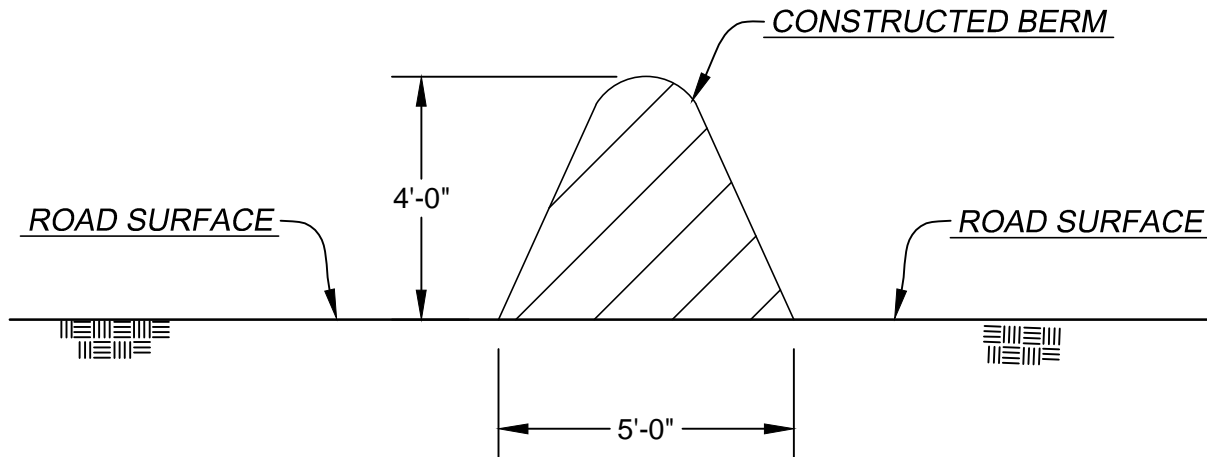

NOTE:

BERM TO BE CONSTRUCTED AFTER SALE IS COMPLETED WITH ROCKS/BOULDERS, LOGGING SLASH, CULL LOGS, STUMPS AND EARTH. AS SHOWN IN ABOVE DRAWING, DO NOT DIG DITCHES ON EITHER SIDE OF BERM FOR BORROW MATERIAL TO CONSTRUCT BERM.

TYPICAL BERM DETAIL
NOT TO SCALE

Ottawa National Forest
Ontonagon Ranger District

Specified Road Plan for Change Out PR Timber Sale Contract prepared by:

T. Kilpela

9/27/2018

TRAVIS KILPELA
Civil Engineering Technician

Date

Engineer Road Cost Estimates

Ottawa National Forest

HDPE Culverts/Pipes	Price per Linear Foot (LF)
12"	\$11.00
15"	\$14.00
18"	\$17.00
24"	\$29.00
30"	\$43.00
36"	\$53.00
Galvanized Metal Pipes - Riveted	Price per LF
12" – 16 gauge	\$14.00
15" – 16 gauge	\$17.00
18" – 16 gauge	\$21.00
24" – 16 gauge	\$26.00
30" – 14 gauge	\$40.00
36" – 14 gauge	\$48.00
Metal Pipe Arch	Price per LF
17"x13" – 16 gauge	\$18.00
21"x15" – 16 gauge	\$23.00
24"x18" – 16 gauge	\$26.00
28"x20" – 16 gauge	\$29.00
35"x24" – 14 gauge	\$44.00
42"x29" – 14 gauge	\$53.00
49"x33" – 12 gauge	\$84.00
57"x38" – 12 gauge	\$96.00
64"x43" – 12 gauge	\$113.00
Local Borrow	\$5.00/Cubic Yard and higher
Geotextile	\$2.50 - \$3.00 per Square Yard
Silt Fence	\$3.00 per LF
Roadwork	
Minor Shaping and Grading	\$900.00 per mile
Maintenance – Shape to Crown/Outslope	\$2,000 to \$3,300 per mile
Reconstruction	\$3,300 to \$4,500 per mile
Shape to Ditch	\$2,700 per mile
Clearing and Widening	\$2,000 per acre
Composite Road Construction	\$4,500 to \$8,500 per mile

CHANGE OUT PR TIMBER SALE SPECIFIED ROAD SCHEDULE OF ITEMS

Item Number	Item Description & Milepost	C or R ¹	Road Std. W,D,S ²	Unit & M of M ³	Quantity	Unit Allowance	Estimated Allowance
FR 1157-F			W				
MP 0.31 Right							
249 02	Construct truck turnaround	C		LS LSQ	1	\$600.00	\$600.00
MP 0.65 Right							
249 02	Construct truck turnaround	C		LS LSQ	1	\$600.00	\$600.00
MP 0.87-1.06							
249 02	Composite Road Construction: Construct road in accordance with the specifications and standard plans.	C		Mile DQ	0.19	\$8,000.00	\$1,520.00
MP 1.03 Right							
249 02	Construct truck turnaround	C		LS LSQ	1	\$600.00	\$600.00
FR 1157-F TOTAL SPECIFIED ROAD SCHEDULE OF ITEMS							\$3,320.00
FR 1157-G			W				
MP 0.00-0.54							
249 02	Composite Road Construction: Reconstruct existing road in accordance with the specifications and standard plans.	R		Mile DQ	0.54	\$4,500.00	\$2,430.00
MP 0.50 Right							
249 02	Construct truck turnaround			LS LSQ	1	\$600.00	\$600.00
FR 1157-G TOTAL SPECIFIED ROAD SCHEDULE OF ITEMS							\$3,030.00
FR 1157-G2			W				
MP 0.00-0.40							
249 02	Composite Road Construction: Reconstruct existing road in accordance with the specifications and standard plans.	R		Mile DQ	0.4	\$4,500.00	\$1,800.00
MP 0.40							
249 02	Construct T truck turnaround	C		LS LSQ	1	\$800.00	\$800.00
FR 1157-G2 TOTAL SPECIFIED ROAD SCHEDULE OF ITEMS							\$2,600.00
FR 1157-H			W				
MP 0.00-0.03							
249 02	Composite Road Construction: Reconstruct existing road in accordance with the specifications and standard plans to be used as truck turnaround.	R		LS LSQ	1	\$600.00	\$600.00

¹C = Construction, R = Reconstruction

²W = Winter, D = Dry Summer, S = Summer

³Method of Measure

**CHANGE OUT PR TIMBER SALE
SPECIFIED ROAD SCHEDULE OF ITEMS**

Item Number	Item Description & Milepost	C or R ¹	Road Std. W,D,S ²	Unit & M of M ³	Quantity	Unit Allowance	Estimated Allowance
FR 1157-H TOTAL SPECIFIED ROAD SCHEDULE OF ITEMS							\$600.00
CHANGE OUT PR TIMBER SALE TOTAL SPECIFIED ROAD SCHEDULE OF ITEMS							\$9,550.00

¹C = Construction, R = Reconstruction

²W = Winter, D = Dry Summer, S = Summer

³Method of Measure

CHANGE OUT PR TIMBER SALE SPECIFIED ROAD NOTES

- NOTE:** There may be underground utility lines in unknown locations on this project. **Call MISS DIG THREE** full working days before any work begins. Phone 1-800-482-7171.
- NOTE:** During clear and grub operations all slash resulting from purchasers operation shall be treated as per CT 6.7#.
- NOTE:** Blading and shaping requires filling in existing ruts and potholes, reestablishing a crown to conform to the typical detail for a crown with no ditches, crown 1' ditches or out sloped roads.
- NOTE:** Additional outlet or lead out ditches may be required at road segment locations to allow for proper drainage needs. Locations for placement shall be determined by the Forest Service.

CHANGE OUT PR TIMBER SALE SPECIFICATIONS

The Forest Service, US Department of Agriculture has adopted FP-14 for construction of National Forest System Roads. FP-14 Standard Specifications are available on-line at <https://flh.fhwa.dot.gov/resources/specs/>. Forest Service Supplemental Specifications to FP-14 are included in the contract.

Road Numbers:		1157-F	1157-G	1157-G2	1157-H	
	Mileposts:	0.87-1.06	0.00-0.54	0.00-0.40	0.00-0.03	
	Construction Miles:	0.19				
	Reconstruction Miles:		0.54	0.40	0.03	
	Truck Turnarounds:	3	1	1		
FP-14 Spec. No.	Title					Latest Revised Edition
101 thru 109	General Requirements	X	X	X	X	2014
FSSS Spec. No.	Title					Latest Revised Edition
101 thru 109	General Requirements	X	X	X	X	2014
249	Composite Road Construction	X	X	X	X	2014

Table of Contents

Preface	6
101 - Terms, Format, and Definitions.....	7
101.01 Meaning of Terms.....	7
101.01 Meaning of Terms.....	7
101.03 Abbreviations.....	7
101.04 Definitions.....	8
102 - Bid, Award, and Execution of Contract	11
Delete Section 102.....	11
103 - Scope of Work	12
Delete Subsections 103.02, 103.03, 103.04, 103.05.....	12
104 - Control of Work.....	13
Delete Subsections 104.01, 104.02, 104.04.....	13
104.03 Specifications and Drawings.....	13
104.06 Use of Roads by Contractor.....	13
105 - Control of Material.....	14
105.02(a) Government-provided sources.....	14
106 - Acceptance of Work.....	15
106.01 Conformity with Contract Requirements.....	15
106.02 Visual Inspection.....	17
106.07 Partial and Final Acceptance.....	17
107 - Legal Relations and Responsibility to the Public	18
Delete Subsection 107.05.....	18
107.08 Sanitation, Health, and Safety.....	18
108 - Prosecution and Progress.....	19
Delete Section 108.....	19
109 - Measurement and Payment	20
Delete Subsections 109.06, 109.07, 109.08, 109.09.....	20
109.02 Measurement Terms and Definitions.....	20
249 - Composite Road Construction	21

Preface

Preface_wo_04_10_2018

Delete all but the first paragraph and add the following:

The Forest Service, US Department of Agriculture has adopted FP-14 for construction of National Forest System Roads.

101 - Terms, Format, and Definitions

101.01_National_9_15_2016

Add the following paragraph to Subsection 101.01:

101.01 Meaning of Terms.

Delete all references to the FAR (Federal Acquisition Regulations) in the specifications when incorporating into 2400-6(T) Timber Sale or 2400-13(T) Stewardship contracts.

101.01_National_9_15_2016

Add the following paragraph to Subsection 101.01:

101.01 Meaning of Terms.

Delete all references to the TAR (Transportation Acquisition Regulations) in the specifications.

101.03_National_4_7_2015

Add the following to Subsection 101.03:

101.03 Abbreviations.

(a) Acronyms.

AGAR — Agriculture Acquisition Regulations

AFPA — American Forest and Paper Association

FSAR — Forest Service Acquisition Regulations

MSHA — Mine Safety and Health Administration

NESC — National Electrical Safety Code

WCLIB — West Coast Lumber Inspection Bureau

(f) Miscellaneous unit abbreviations.

MP — milepost location

ppm — parts per million volume

STA station location

Make the following changes to Subsection 101.04:

101.04 Definitions.

Delete these definitions and replace the following:

Bid Schedule — The Schedule of Items.

Bridge — A structure, including supports, erected over a depression or an obstruction such as water along a road, a trail, or a railway and having a deck for carrying traffic or other loads.

Contractor — The individual or legal entity contracting with the Government for performance of prescribed work. In a timber sale contract, the contractor is the “Purchaser”.

Culvert — Any structure with a bottom, regardless of fill depth, depth of invert burial, or presence of horizontal driving surface, or any bottomless (natural channel) structure with footings that will not have wheel loads in direct contact with the top of the structure.

Drawings — (Public Works Contracts) Design sheets or fabrication, erection, or construction details submitted to the CO by the Contractor according to FAR Clause 52.236-21 Specifications and Drawings for Construction. Also refers to submissions and submittals.

Notice to Proceed — (Public Works Contracts) Written notice to the Contractor to begin the contract work.

Right-of-Way — A general term denoting (1) the privilege to pass over land in some particular line (including easement, lease, permit, or license to occupy, use, or traverse public or private lands), or (2) Real property necessary for the project, including roadway, buffer areas, access, and drainage areas.

Solicitation—(Public Works Contracts) The complete assembly of documents (whether attached or incorporated by reference) furnished to prospective bidders.

Add the following definitions:

Adjustment in Contract Price — “Equitable adjustment,” as used in the Federal Acquisition Regulations, or “construction cost adjustment,” as used in the Timber Sale Contract, as applicable.

Change — “Change” means “change order” as used in the Federal Acquisition Regulations, or “design change” as used in the Timber Sale Contract.

Forest Service — The United States of America, acting through the Forest Service, U.S. Department of Agriculture.

Neat Line — A line defining the proposed or specified limits of an excavation or structure.

Pioneer Road — Temporary construction access built along the route of the project.

Purchaser — The individual, partnership, joint venture, or corporation contracting with the Government under the terms of a Timber Sale Contract and acting independently or through agents, employees, or subcontractors.

Protected Streamcourse — A drainage shown on the plans or timber sale area map that requires designated mitigation measures.

Road Order — An order affecting and controlling traffic on roads under Forest Service jurisdiction. Road Orders are issued by a designated Forest Officer under the authorities of 36 CFR, part 260.

Shop Drawings — (Timber and Stewardship Contracts) Referred to as “Drawings” in FP-14, include drawings, diagrams, layouts, schematics, descriptive literature, illustrations, lists or tables, performance and test data, and similar materials furnished by Purchaser to explain in detail specific portions of the work required by the contract.

Utilization Standards — The minimum size and percent soundness of trees described in the specifications to determine merchantable timber.

Add Figure 101-1—Illustration of road structure terms:

Figure 101-1—Illustration of road structure terms.

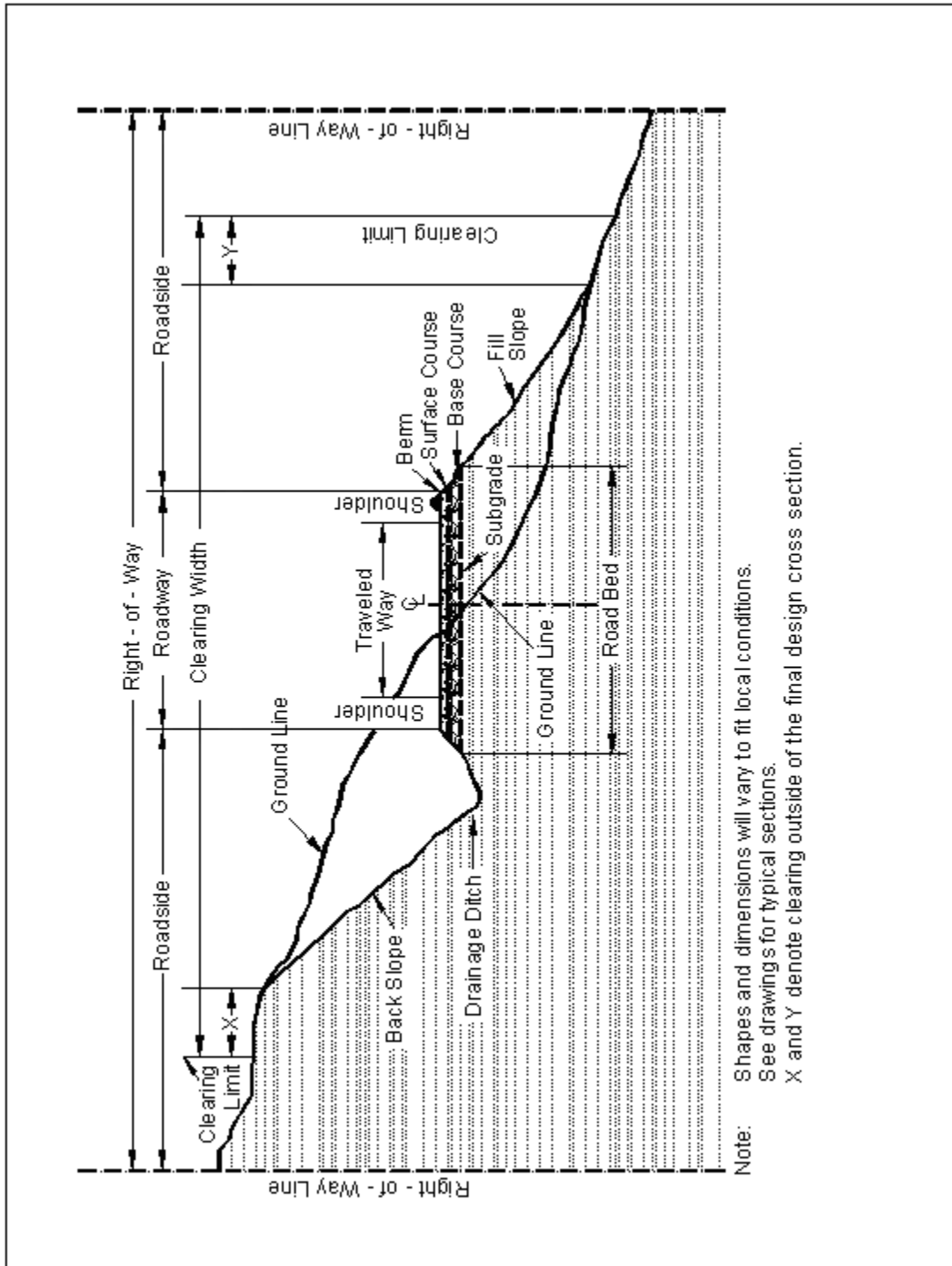

102 - Bid, Award, and Execution of Contract

102.00_National_9_15_2016

Delete Section 102 in its entirety.

Delete Section 102.

103 - Scope of Work

103.00_National_9_15_2016

Delete all of Section 103 except Subsection 103.01 Intent of Contract.

Delete Subsections 103.02, 103.03, 103.04, 103.05.

104 - Control of Work

104.00_National_9_15_2016

Delete Subsections 104.01, 104.02, and 104.04.

Delete Subsections 104.01, 104.02, 104.04.

104.03_National_10_23_2016

Delete Subsection 104.03 and replace with the following:

104.03 Specifications and Drawings.

Refer to B(T) 5.211 in the 2400-6(T)) or F(T).2.1.1 in the 2400-13(T) contracts for requirements under this subsection.

104.06_National_9_16_2016

Add the following to Subsection 104.06:

104.06 Use of Roads by Contractor.

The Contractor is authorized to use roads under the jurisdiction of the Forest Service for all activities necessary to complete this contract, subject to the limitations and authorizations designated in the Road Order(s) or described in the contract, when such use will not damage the roads or national forest resources, and when traffic can be accommodated safely.

105 - Control of Material

105.02_National_10_23_2016

Add the following to Subsection 105.02(a):

105.02(a) Government-provided sources.

Government-provided sources for this project are identified as follows:

(1) Government-provided mandatory sources.

Pay Item	Description	Material source number or name

(2) Government-provided optional sources for this project are identified as follows:

Pay Item	Description	Material source number or name

106 - Acceptance of Work

106.01_National_7_18_2017

Delete Subsection 106.01 and replace with the following:

106.01 Conformity with Contract Requirements.

Follow the requirements of FAR Clause 52.246-12 Inspection of Construction.

References to standard test methods of AASHTO, ASTM, GSA, and other recognized standard authorities refer to the methods in effect on the date of solicitation for bids.

Perform all work to the lines, grades, cross-sections, dimensions, and processes or material requirements shown on the plans or specified in the contract.

Incorporate manufactured materials into the work according to the manufacturer's recommendations or to these specifications, whichever is more strict.

Plan dimensions and contract specification values are the values to be strived for and complied with as the design values from which any deviations are allowed. Perform work and provide material that is uniform in character and reasonably close to the prescribed value or within the specified tolerance range. The purpose of a tolerance range is to accommodate occasional minor variations from the median zone that are unavoidable for practical reasons.

When standard manufactured items are specified (such as fence, wire, plates, rolled shapes, pipe conduits, etc., that are identified by gauge, unit mass, section dimensions, etc.), the identification will be considered to be nominal masses or dimensions. Unless specific contract tolerances are noted, established manufacturing tolerances will be accepted.

The Government may inspect, sample, or test all work at any time before final acceptance of the project. When the Government tests work, copies of test reports are furnished to the Contractor upon request. Government tests may or may not be performed at the work site. If Contractor testing and inspection is verified by the Government, the Contractor's results may be used by the Government to evaluate work for acceptance. Do not rely on the availability of Government test results for process control.

Acceptable work conforming to the contract will be paid for at the contract unit bid price. Four methods of determining conformity and accepting work are described in Subsections 106.02 to 106.05 inclusive. The primary method of acceptance is specified in each Section of work. However, work may be rejected at any time it is found by any of the methods not to comply with the contract.

Remove, repair, or replace work that does not conform to the contract, or to prevailing industry standards where no specific contract requirements are noted. Removing, repairing, or replacing work; providing temporary traffic control; and any other related work to accomplish conformity will be at no cost to the Government.

(a) Disputing Government test results. If the accuracy of Government test results is disputed, promptly inform the CO. If the dispute is unresolved after reasonable steps are taken to resolve the dispute, further evaluation may be obtained by written request. Include a narrative describing the dispute and a proposed resolution protocol that addresses the following:

1. Sampling method;
2. Number of samples;
3. Sample transport;
4. Test procedures;
5. Testing laboratories;
6. Reporting;
7. Estimated time and costs; and
8. Validation process.

If the evaluation requires additional sampling or testing be performed, mutually agree with the Government on witnessing procedures and on sampling and testing by a third party laboratory. Use a third party laboratory accredited by the AASHTO accreditation program. Provide proof of the laboratory's accreditation for the test procedures to be used. Do not use the same laboratory that produced the disputed Government test results or that produced the test results used as a basis for the dispute.

The CO will review the proposed resolution protocol and may modify it before final approval and execution.

The Government will use the approved resolution protocol test results to determine the validity of the disputed testing. If the Government test results are validated, the Contractor will be responsible for all costs associated with developing and performing the resolution protocol. If the Government test results are not validated, the Government will be responsible for all costs associated with developing and performing the resolution protocol. If the validity of the Government test results cannot be determined, the Contractor and Government will equally share all costs associated with developing and carrying out the resolution protocol.

(b) Alternatives to removing and replacing non-conforming work. As an alternative to removal and replacement, the Contractor may submit a written request to:

1. Have the work accepted at a reduced price; or
2. Be given permission to perform corrective measures to bring the work into conformity.

The request must contain supporting rationale and documentation. Include references or data justifying the proposal based on an evaluation of test results, effect on service life, value of material or work, quality, aesthetics, and other tangible engineering basis. The CO will determine disposition of the nonconforming work.

Delete Subsection 106.02 and replace with the following:

106.02 Visual Inspection.

Acceptance is based on visual inspection of the work for compliance with the specific contract requirements. Use prevailing industry standards in the absence of specific contract requirements or tolerances.

106.07_National_10_23_2016

Delete Subsection 106.07.

106.07 Partial and Final Acceptance.

107 - Legal Relations and Responsibility to the Public

107.05_National_7_18_2017

Delete Subsection 107.05.

Delete Subsection 107.05.

107.08_National_10_23_2016

Delete Subsection 107.08 and replace with the following:

107.08 Sanitation, Health, and Safety.

Refer to specific provisions under B(T) 6.0 in the 2400-6(T) or G(T).0 in the 2400-13(T) contracts for requirements under this subsection.

108 - Prosecution and Progress

108.00_National_9_16_2016

Delete Section 108 in its entirety.

Delete Section 108.

109 - Measurement and Payment

109.00_National_9_16_2016

Delete Subsections 109.06, 109.07, 109.08, and 109.09:

Delete Subsections 109.06, 109.07, 109.08, 109.09.

109.02_National_9_16_2016

Add the following sentence to Subsection 109.02(b):

109.02 Measurement Terms and Definitions.

(b) Contract quantity.

Contract quantities will be adjusted only when there are errors in the original design of 15% or more.

249 - Composite Road Construction

249.01 Description

This work consists of clearing and grubbing, excavation and embankment, and removal of all construction slash including all trees designated for removal. Excavation and embankment includes on site borrow excavation; drainage excavation; placing all excavated material; and shaping the roadway; including approaches, turnarounds, ditches and drainage dips. Construct the roadway in conformance with the dimensions “shown on the plans” or as staked on the ground.

249.02 Clearing and Disposal

Protect construction stakes and construction control markers. Remove or treat all trees, snags, downed timber, brush, and stumps within the clearing limits according to the following specifications.

- (a) Merchantable Timber. Treat according to the Utilization Standards of the Timber Sale Contract.

- (b) Unmerchantable Timber. Treat according to Subsection 249.02 Method A.

- (c) Large Construction Slash. Treat construction slash larger than 3 inches in diameter and longer than 3 feet by one or more of the following methods.
 - (1) Method A. Construction slash shall be scattered outside the clearing limits without damaging trees outside the clearing area. Logs shall be placed away from trees, positioned so that they will not roll, not placed on top of one another or left leaning on other trees. Scattered stumps shall be placed in an upright position

(2) Method B. Stumps, roots, rocks, topsoil and other grubbing debris shall be concentrated in stump dump areas. Stump dump areas shall be located by the Engineer, be a maximum of 300 feet apart along the road centerline, and generally be located in natural depressions or tucked away behind denser vegetation or ground rises. Stump dumps will vary in size depending on each site, but shall not be closer than 10 feet outside of the clearing limits. Stump dump material shall be matted down as much as possible and shall not obstruct natural drainages.

(d) Small Construction Slash. Construction slash less than 3 inches in diameter and less than 3 feet in length may be incorporated into embankments so long as the material is distributed so that it does not result in concentrations or matting.

Immediately remove slash deposited in stream courses.

249.03 Pioneering

Do not undercut the final back slope during pioneer operations. Deposit material inside the roadway limits. Do not restrict drainages.

249.04 Grubbing.

Grub within the specified limits. Stumps outside the grubbing limits remain if cut no higher than 1 foot or one-third of the stump diameter, whichever is greater, above the original ground, measured on the uphill side, unless otherwise designated. Grub all stumps from the Roadway, or stumps that have less than 1 foot of cover, in the Fill slopes, providing they do not interfere with the placement or compaction of embankments.

249.05 Excavation and Embankment.

Construct the roadway to conform to the typical sections shown on the plans. Protect backslopes from being undercut. Embankment shall be placed in layers no more than 12 inches thick.

Locate and use borrow material, and remove and treat unsuitable excess material, as designated.

Place rocks that are too large to be incorporated in the embankment outside the traveled way on the downhill side such that they will not roll, obstruct drainage, or hinder roadbed use and maintenance.

Shape and finish the roadbed to the condition ordinarily accomplished by a crawler tractor with dozer blade to provide drainage of surface water. Do not permit individual rocks to protrude more than 4 inches above the subgrade of the roadbed. A motor grader finish is not required.

Observe a width tolerance of (+) 18 inches max. for the roadbed.

Where shown on the drawings or designated on the ground, offtake ditches shall be constructed to drain water away from the roadbed.

249.06 Erosion Control.

Perform erosion control measures, where shown on the drawings, or staked on the ground.

249.07 Method.

Measure the section 249 items listed in the schedule of items according to subsection 109.02

Payment

249.08 Basis.

The accepted quantities will be paid at the contract price per unit of measurement for Section 249 pay items listed in the Bid Schedule. Payment will be full compensation for the work prescribed in this section. See Subsection 109.05

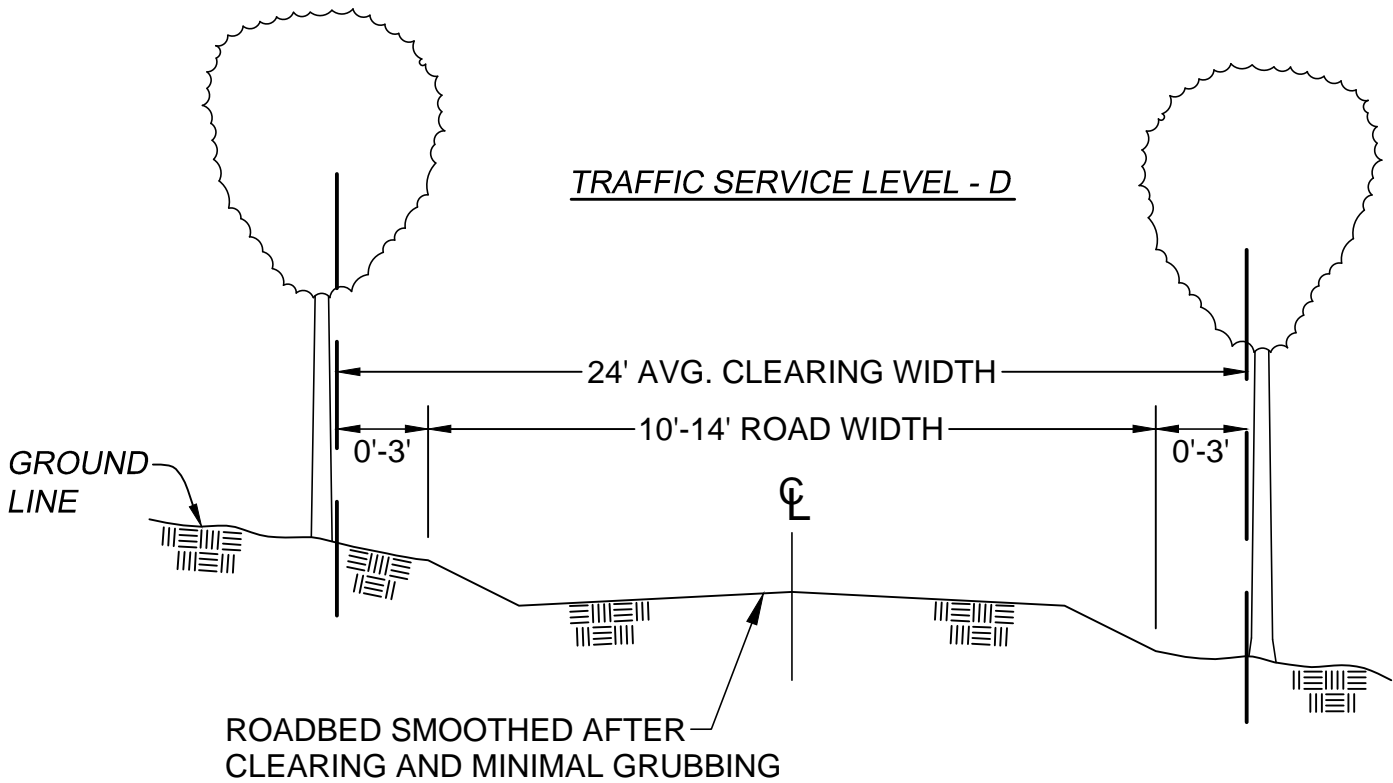

CROSS SECTION VIEW

WINTER ONLY ROAD STANDARD

NOT TO SCALE

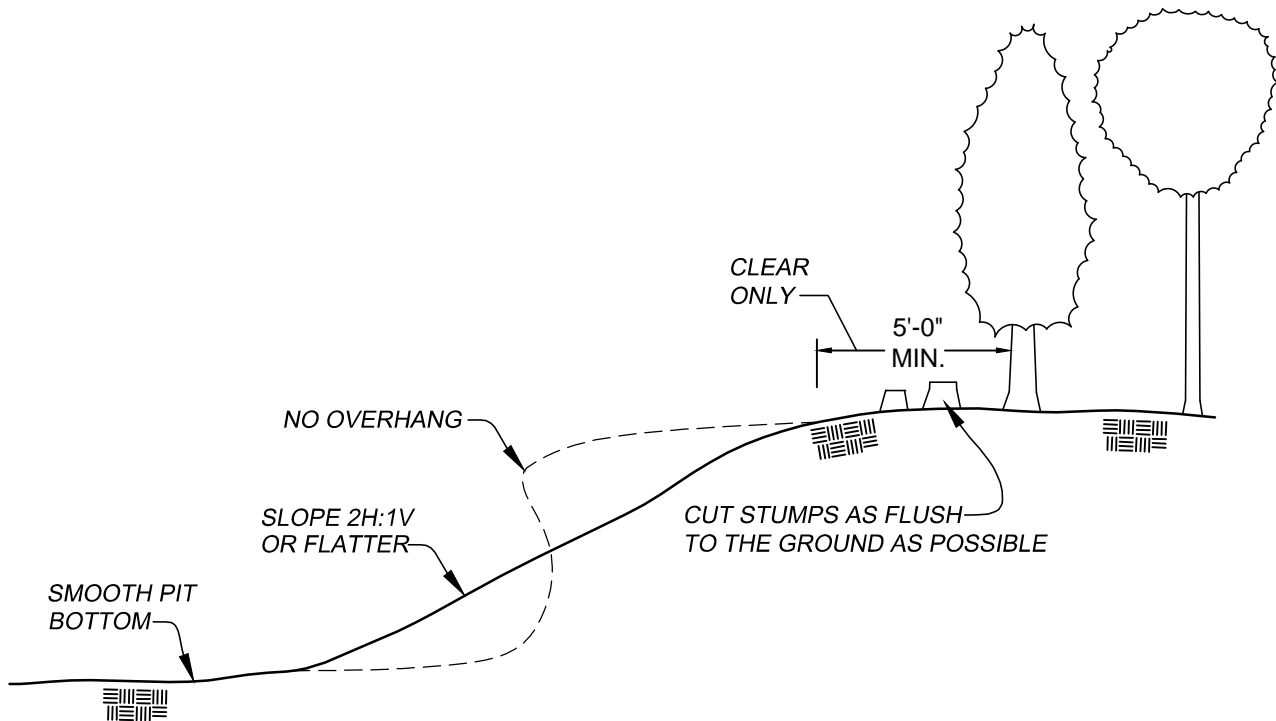

NOTE: TOPS, STUMPS AND TRUNKS SHALL BE DISPOSED OF AS DIRECTED BY THE FOREST SERVICE. STUMPS SHALL BE SEVERED FROM ALL TREES. OVERSIZED ROCK SHALL BE DISPOSED OF IN EXISTING PILES OR AS DIRECTED BY THE FOREST SERVICE. SMOOTH PIT BOTTOM TO REDUCE THE COLLECTION OF WATER. HAUL ROADS SHALL BE MADE SMOOTH AND REPAIRED OF DAMAGE CAUSED BY THE CONTRACTORS HAULING OPERATION OR EQUIPMENT.

BORROW PIT CLEAN UP

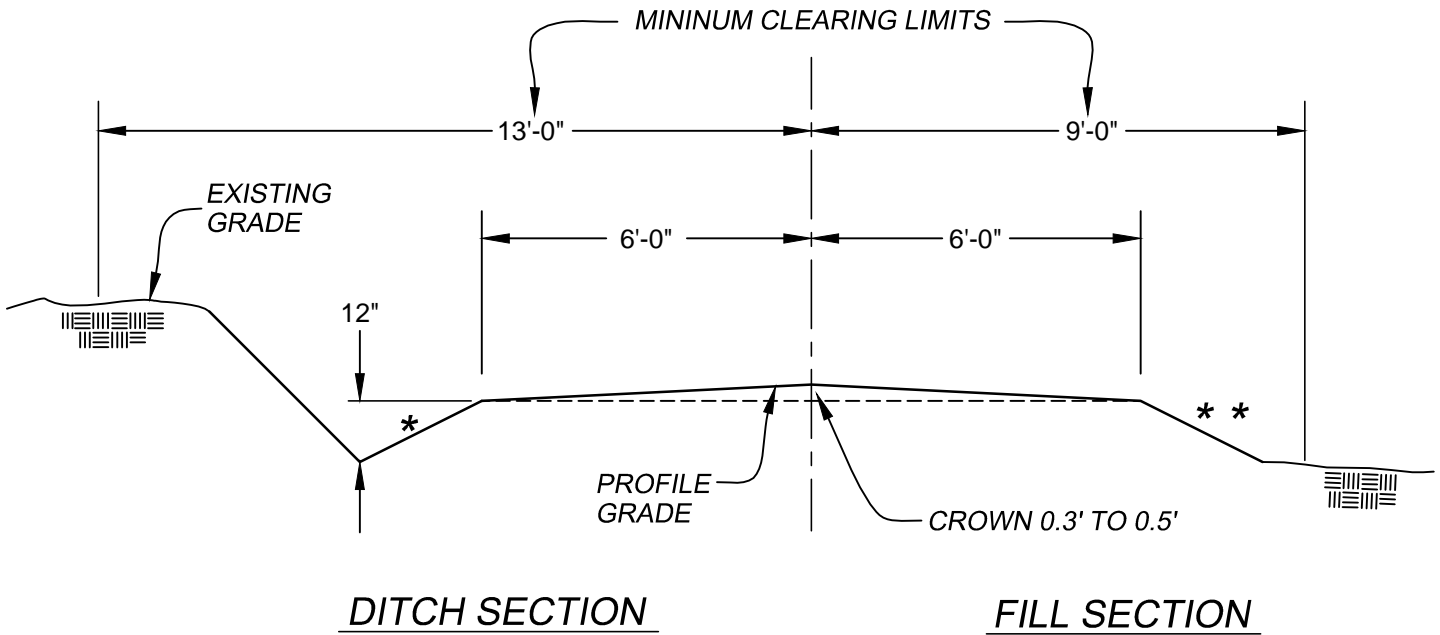

*BACKSLOPE AND DITCH SLOPES MAY VARY FROM 1H:1V TO 2H:1V WHEN CUTS ARE UNDER 2 FT. CUTS OVER 2 FT. SHALL HAVE SLOPES OF 2H:1V

**FILL SLOPES MAY VARY FROM 1-1/2H:1V TO 3H:1V

(SEE NARRATIVE FOR LOCATION)

TYPICAL CROSS SECTION WITH 1 FOOT DITCH
NOT TO SCALE

Sale Area Map

Change Out P.R. Timber Sale
Ottawa National Forest
Ontonagon Ranger District
Houghton & Ontonagon County
Compartment # 125, 128, 149 & 151
Gross Sale Area = 891 acres
Net Sale Area = 344 acres

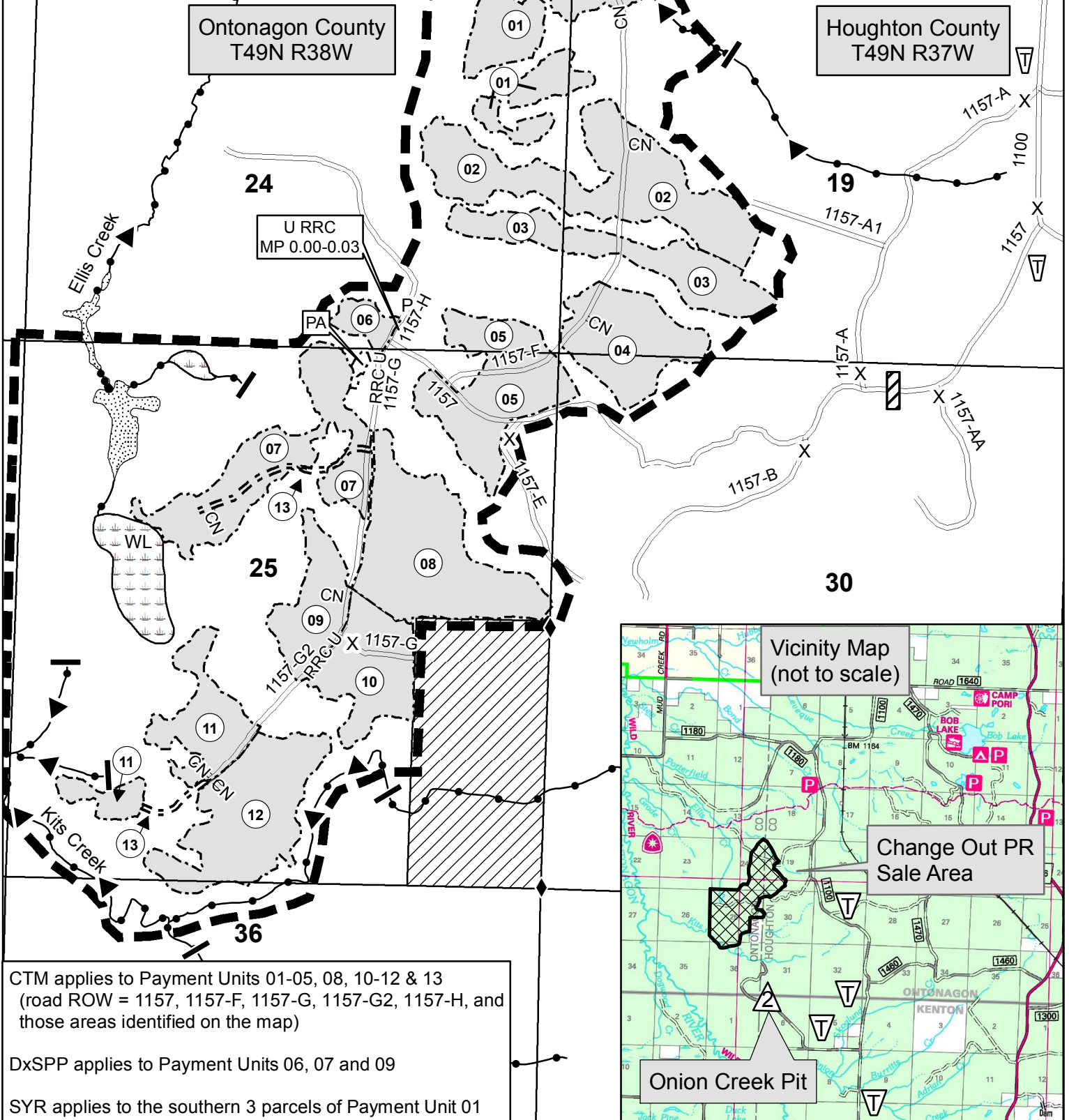







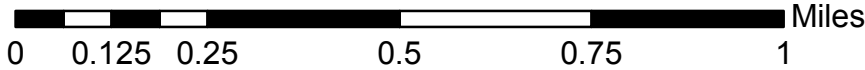
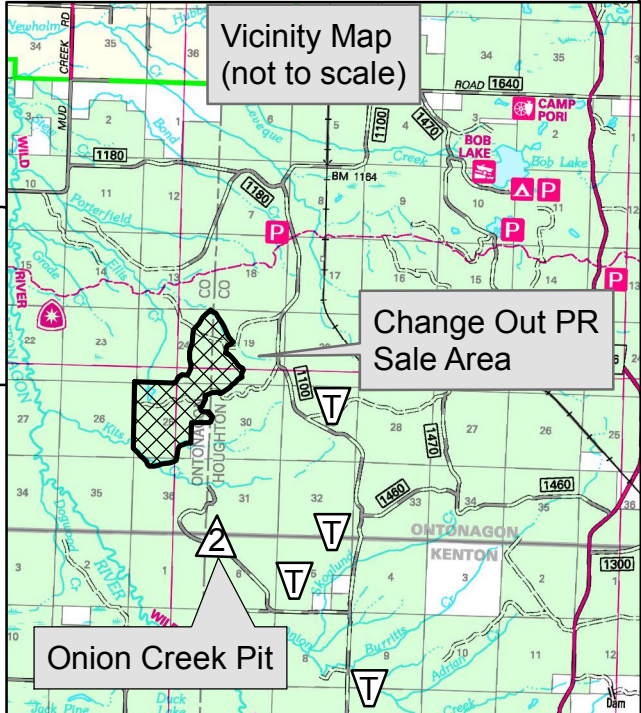

CTM applies to Payment Units 01-05, 08, 10-12 & 13
(road ROW = 1157, 1157-F, 1157-G, 1157-G2, 1157-H, and those areas identified on the map)

DxSPP applies to Payment Units 06, 07 and 09

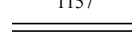
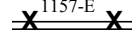
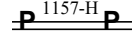
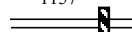
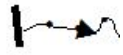
SYR applies to the southern 3 parcels of Payment Unit 01



LEGEND

	Sale Area Boundary, BT1.1
	Payment Unit Boundary, BT1.1
	Payment Unit Number, BT1.1
CTM	Cut Tree Marked Prior to Advertisement, BT2.35, CT2.355#, CT6.412
DxSPP	Designation By Species and Diameter, CT2.352#
1157 	Existing Transportation System Road, BT5.12, BT6.22
1157-E 	Existing Transportation System Road, Hauling Prohibited, CT5.12#, BT6.22
1157-H 	Existing Transportation System Road, Use Prohibited, CT5.12#, BT6.22
1157-G RRC RRC	Specified Road Reconstruction, AT7, BT5.2, BT5.23, BT6.22, BT6.222, BT6.361
1157-G U U	Existing Transportation System Road, Unsuitable for hauling prior to completion of agreed reconstruction, BT5.12, BT5.23, BT6.22, CT5.12#
1157-F CN CN	Specified Road Construction (New), AT7, BT5.2, BT5.23, BT6.22, BT6.222, BT6.361
1157 	Purchaser Remove & Install Berm on System Road, CT5.31#, BT6.22, T-8620
	Streamcourse Protection, BT6.5 (block represents upper stream limit; arrow indicates flow direction)
SYR	Skidding and Yarding Requirements, CT6.42#
PA	Protected Area, CT2.301# & BT6.24
	Material Source, Pit-Run Gravel, CT5.221# (Onion Creek Pit)
	Other Ownership, CT6.7#
	Wetlands Protection, BT6.62, CT6.62#
	Lakes, CT6.7#
	Traffic Control Device, BT6.33 (Safety)
	Protection of Land Survey Monuments (Monumented Corner), BT6.23